

# BODYCRAFT

## Assembly and Operating Instructions

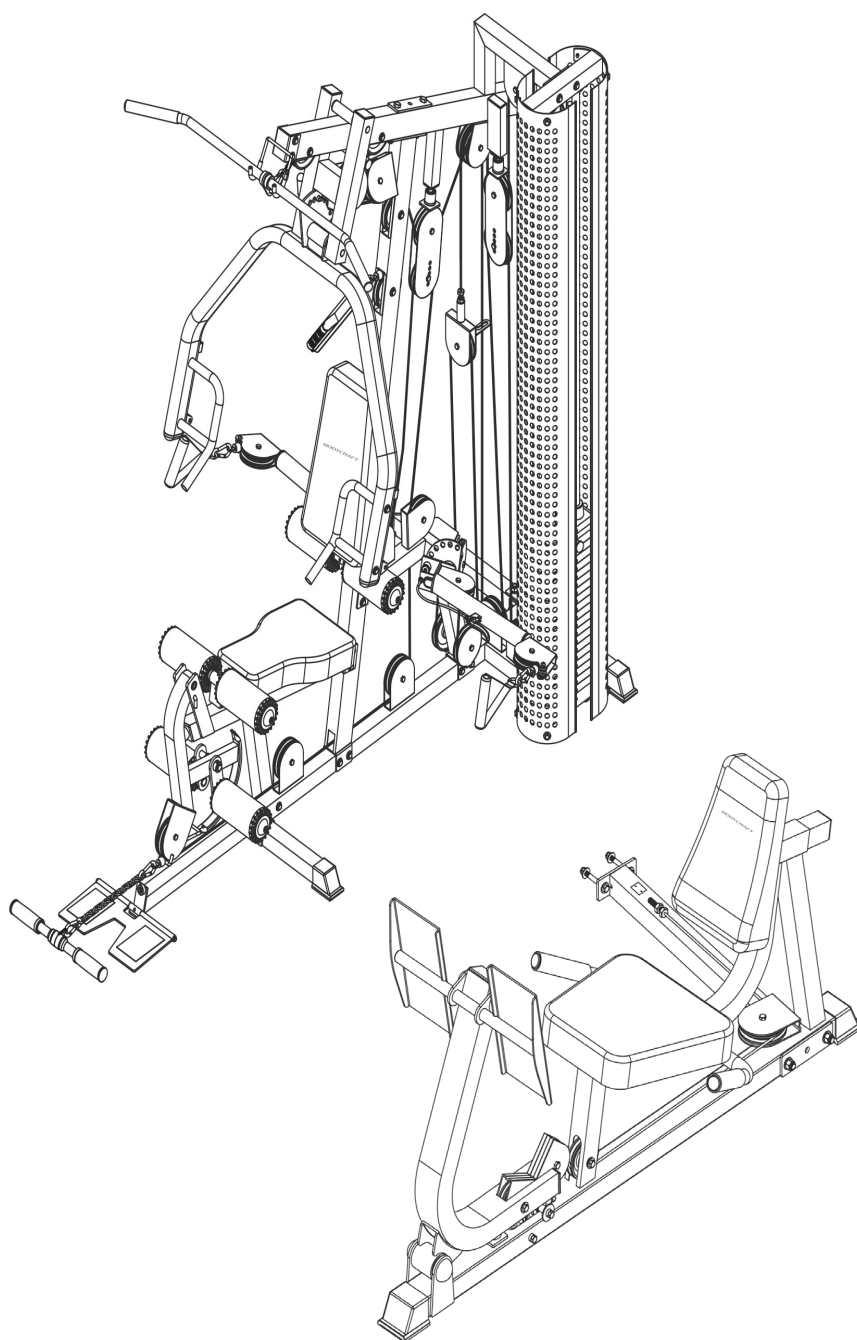

~ 330 Min.



240 kg

L 210 | W 144 | H 210



max. 150 kg



~ 120 Min.



36 kg

L 102 | W 154 | H 82

SW950202.01.04

Art. No. SW-95.0202 / SW-XPRESS-LEG

BodyCraft X-Press Pro



# Content

<b>1</b>	<b>GENERAL INFORMATION</b>	<b>6</b>
1.1	Technical Data	6
1.2	Personal Safety	7
1.3	Set-Up Place	8
<b>2</b>	<b>ASSEMBLY</b>	<b>9</b>
2.1	General Instructions	9
2.2	Scope of Delivery: Multi-gym	10
2.3	Assembly: Multi-gym	13
2.4	Scope of Delivery: Leg Press	23
2.5	Assembly: Leg Press	25
<b>3</b>	<b>STORAGE AND TRANSPORT</b>	<b>32</b>
3.1	General Instructions	32
<b>4</b>	<b>TROUBLESHOOTING, CARE AND MAINTENANCE</b>	<b>33</b>
4.1	General Instructions	33
4.2	Faults and Fault Diagnosis	33
4.3	Maintenance and Inspection Calendar	34
<b>5</b>	<b>DISPOSAL</b>	<b>34</b>
<b>6</b>	<b>RECOMMENDED ACCESSORIES</b>	<b>35</b>
<b>7</b>	<b>ORDERING SPARE PARTS</b>	<b>36</b>
7.1	Serial Number and Model Name	36
7.2	Parts List: Multi-gym	37
7.3	Exploded Drawing: Multi-gym	42
7.4	Parts List: Leg Press	43
7.5	Exploded Drawing: Leg Press	44
<b>8</b>	<b>WARRANTY</b>	<b>45</b>
<b>9</b>	<b>CONTACT</b>	<b>47</b>

**Dear customer,**

Thank you for choosing BodyCraft® training equipment. BodyCraft® inspires with its multifunctionality and excellent workmanship and is one of the highest quality fitness equipment for home use in terms of innovation and technology. BodyCraft® weight stations, for example, offer a very wide range of exercise possibilities. This ranges from traditional strength training such as bench presses to rehabilitation exercises and workouts for complex sports such as golf, tennis or badminton.

Further information can be found at [www.sport-tiedje.com](http://www.sport-tiedje.com).

**Intended Use**

The equipment may only be used for its intended purpose.

The equipment is only suitable for home use. The equipment is not suitable for semi-professional (e.g. hospitals, associations, hotels, schools, etc.) and commercial or professional use (e.g. fitness studios).

**Disclaimer**

***BODYCRAFT***

BodyCraft® is a registered brand of the company Fitness Authority Industrial Co., LTD. All rights reserved. Any use of this trademark without the explicit written permission of Fitness Authority Industrial Co., LTD is prohibited.

Product and manual are subject to change. Technical data can be changed without advance notice.

## ABOUT THIS MANUAL

Please carefully read the entire manual before installation and first use. The manual will help you to quickly set up the system and explains how to safely use it. Make sure that all persons exercising with the equipment (especially children and persons with physical, sensory, mental or motor disabilities) are informed about this manual and its contents in advance. In case of doubt, responsible persons must supervise the use of the equipment.

Due to ongoing changes and software optimisations, the manual may have to be updated. If you notice any discrepancies during assembly or use, please refer to the manual uploaded to the webshop. The latest manual is always available there.

This equipment has been manufactured according to the latest safety knowledge. As far as possible, potential safety hazards which could cause injury have been eliminated. Make sure to carefully follow the instructions and that all parts are securely in place. If required, read through the instructions again to correct any mistakes.



Please pay close attention to the safety and maintenance instructions given here. The contract partner cannot be held liable for damage to health, accidents or damage to the equipment when it is not used in accordance with these instructions.

The following safety instructions may appear in this manual:

► **ATTENTION**

This notice indicates potentially hazardous situations which, if not avoided, may result in property damage.

⚠ **CAUTION**

This notice indicates potentially hazardous situations which, if not avoided, may result in slight or minor injuries!

⚠ **WARNING**

This notice indicates potentially hazardous situations which, if not avoided, may result in death or serious injuries!

⚠ **DANGER**

This notice indicates potentially hazardous situations which, if not avoided, will result in death or serious injuries!

ⓘ **NOTICE**

This notice indicates further useful information.

Retain these instructions in a safe place for future reference, maintenance or when ordering replacement parts.

## 1.1 Technical Data

### Multi-gym

#### Weight and Dimensions

Packaging dimensions (L x W x H) and article weight (gross, incl. packaging) approx.:

SW-95.0202/2:	110 cm x 105 cm x 30 cm	89.5 kg
SW-95.0202/3:	204 cm x 32 cm x 17 cm	20.5 kg
SW-95.0000-5:	27 cm x 14 cm x 14 cm	23.02 kg
SW-95.0000-7 (2x):	27 cm x 21 cm x 13 cm	33 kg
SW-95.0202/1:	190 cm x 55 cm x 20 cm	60.5 kg

Article weight (net, without packaging) approx.:	235.1 kg
Set-up dimensions (L x W x H) approx.:	210 cm x 144 cm x 210 cm

Weight stack:	1 (90 kg)
Maximum user weight:	150 kg

Transmission ratio	
Lat pull-down:	1:1
Press arm	1:1 (#126 connect cable required)
Ab crunch:	1:1
Cable arm (one side):	2:1
Leg extension:	1:1
Low row:	1:1

#### Optional Leg Press

#### Weight and Dimensions

Packaging dimensions (L x W x H) approx.:	156 cm x 64 cm x 18 cm
Set-up dimensions (L x W x H) approx.:	102 cm x 154 cm x 82 cm

Article weight (gross, incl. packaging) approx.:	40.4 kg
Article weight (net, excl. packaging) approx.:	36 kg

Maximum user weight:	150 kg
----------------------	--------

Transmission ratio:	1:4
---------------------	-----

## 1.2 Personal Safety

### **DANGER**

- + Before you start using the equipment, you should consult your physician that this type of exercise is suitable for you from a health perspective. Particularly affected are persons who: have a hereditary disposition to high blood pressure or heart disease, are over the age of 45, smoke, have high cholesterol values, are overweight and/or have not exercised regularly in the past year. If you are under medical treatment that affects your heart rate, medical advice is absolutely essential.
- + Note that excessive training can seriously endanger your health. Please also note that heart rate monitoring systems can be inaccurate. If you notice any signs of weakness, nausea, dizziness, pain, shortness of breath, or other abnormal symptoms, stop exercising immediately and seek advice from your doctor if necessary.

### **WARNING**

- + This equipment may not be used by children under the age of 14.
- + Children should not be allowed unsupervised access to the equipment.
- + Persons with disabilities must have a medical license and must be under strict observation when using the equipment.
- + The equipment is strictly for use by one person at a time.
- + If your equipment provides a safety key, the clip of the safety key must be attached to your clothing before starting your training. In the event of a fall, the EMERGENCY STOP of the equipment can be initiated.
- + Keep your hands, feet and other body parts, hair, clothing, jewellery and other objects well clear of moving parts.
- + During use, wear suitable sports clothing rather than loose or baggy clothing. When wearing sports shoes, make sure they have suitable soles, preferably made of rubber or other non-slip materials. Shoes with heels, leather soles, studs or spikes are unsuitable. Never exercise barefoot.

### **CAUTION**

- + If your equipment needs to be connected to the power supply with a mains cable, make sure that the cable is not a potential tripping hazard.
- + Make sure that nobody is within the range of motion of the equipment during training so as not to endanger you or other persons.

### **ATTENTION**

- + Do not insert any objects of any kind into the openings of the device.

## 1.3 Set-Up Place

### **WARNING**

- + Do not place the equipment in main corridors or escape routes.

### **CAUTION**

- + The training room should be well ventilated during training and not be exposed to any draughts.
- + Choose the place in which to set up the equipment such that there is enough free space/clearance to the front, the rear and to the sides of the equipment.
- + The set-up and mounting surface of the equipment should be flat, loadable and solid.

### **ATTENTION**

- + The device may only be used in one building, in sufficiently tempered and dry rooms (ambient temperatures between 10°C and 35°C). The equipment should not be used outdoors or in rooms with high humidity (over 70%) like swimming pools.
- + A floor protective mat/equipment underlay can help to protect high-quality floor coverings (parquet, laminate, cork, carpets) from dents and sweat and can help to level out slight unevenness.



### 2.1 General Instructions



#### **DANGER**

- + Do not leave any tools, packaging materials such as foils or small parts lying around, as otherwise there is a danger of suffocation for children. Keep children away from the equipment during assembly.



#### **WARNING**

- + Pay attention to the instructions attached to the equipment in order to reduce the risk of injuries.



#### **CAUTION**

- + Do not open the packaging when it is lying on its side.
- + Ensure to have sufficient room for movement in each direction during assembly.
- + The assembly of the equipment must be carried out by at least two adults. If in doubt, seek the help of a third technically skilled person.



#### **ATTENTION**

- + To prevent damage to the equipment and the floor, assemble the equipment on a mat or packaging board.



#### **NOTICE**

- + In order to make the assembly as simple as possible, some screws and nuts to be used can already be pre-assembled.
- + Ideally, assemble the equipment at its later set-up place.

## 2.2 Scope of Delivery: Multi-gym

The scope of delivery consist of the following parts. At the beginning, check whether all parts and tools belonging to the device are included in the scope of delivery and whether damage has occurred. In the event of complaints, the contractual partner must be contacted directly.

**⚠ CAUTION**

If parts of the scope of delivery are missing or damaged, the assembly must not be carried out.

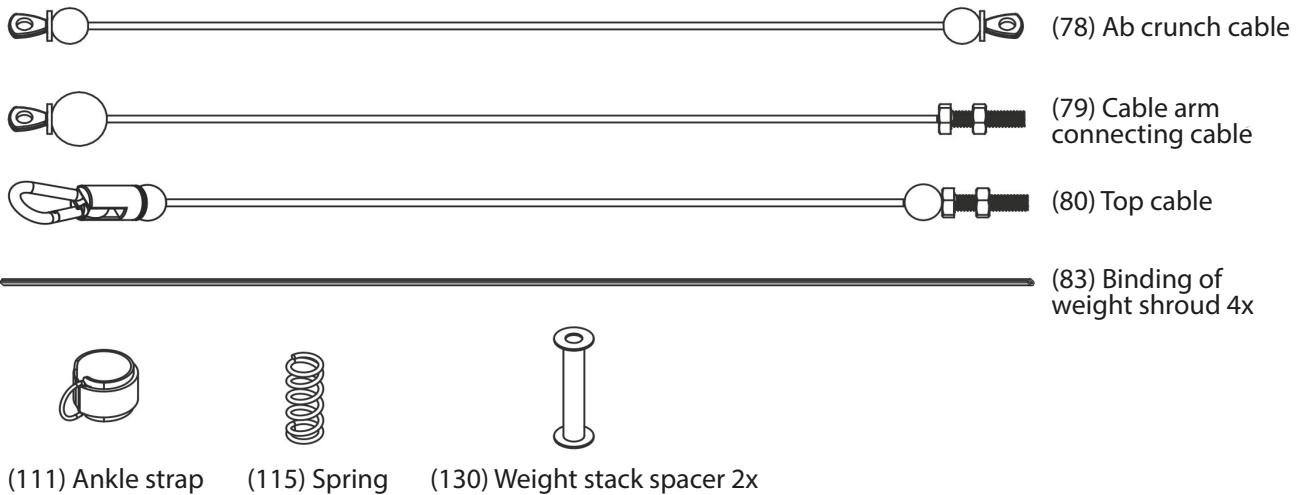

NO.	DESCRIPTION	QTY.
-----	-------------	------

84	1/2" X 4" Hex head bolt	2
85	1/2" X 3" Hex head bolt	4
86	3/8" X 5-3/4" Hex head bolt	1
87	3/8" X 4-1/2" Hex head bolt	1
88	3/8" X 3" Hex head bolt	13
89	3/8" X 2-3/4" Hex head bolt	4
90	3/8" X 2-1/2" Hex head bolt	4
91	3/8" X 1-3/4" Hex head bolt	17
92	3/8" X 1-3/4" Hex head bolt	2
93	3/8" X 1" Hex head bolt	4
95	5/16" X 1/2" Hex head bolt	8
101	3/8" Washer	50
102	5/16" Smaller washer	8
106	1/2" Nylon nut	6
107	3/8" Nylon nut	41
109	Top plate bolt	1

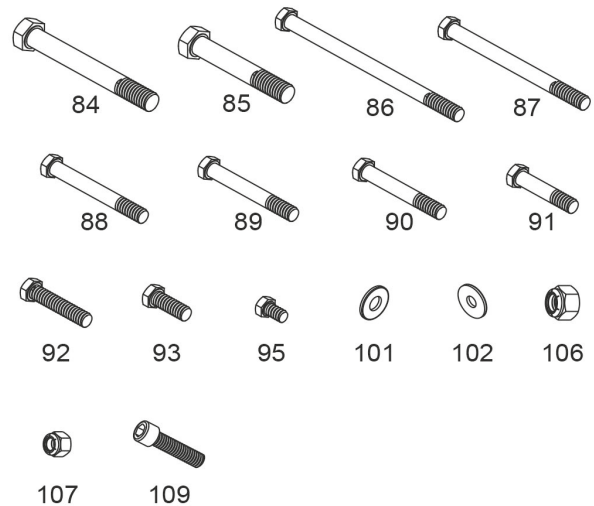

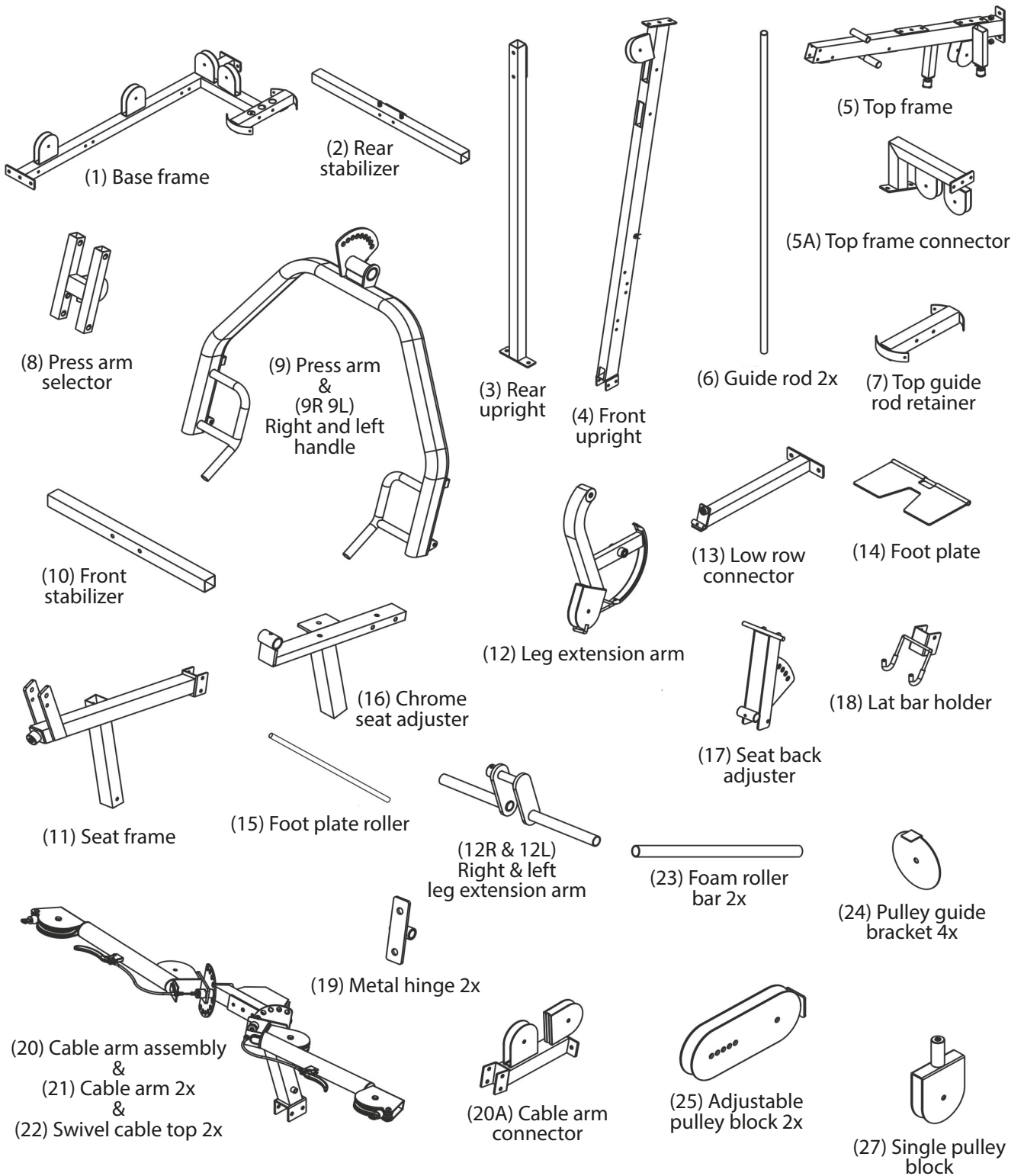



(27A) Cable guide plate

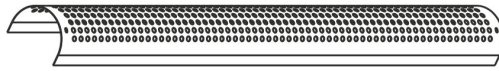

(28) Weight shroud 2x

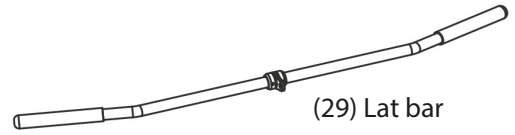

(29) Lat bar

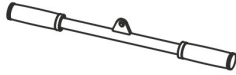

(30) Low row bar

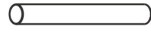

(31) Pivot axle

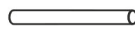

(31A) 19.92 axle

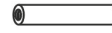

(33) Leg extension axle

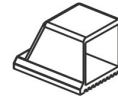

(40) 50mm sq. cap 4x



(41) 50mm sq. plug 5x



(41A) 40x80mm elliptic plug 2x



(43) 30x60mm rect. plug



(44) 25x50mm rect. plug



(45) Plastic cover 6x



(45A) Plastic washer 6x



(46) 1/2" round plug 2x



(47) Plastic guide rod holder 4x



(51) Red pop pin 2x



(53) Spring knob



(54) Magnetic selector pin



(55) L pin



(61) Pulley 31x

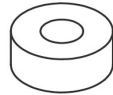

(63) Rubber donut 2x



(67) Top plate

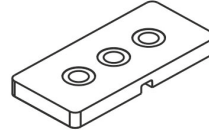

(68) 10 lb plate 19x



(69) Selector rod



(70) Non slip 4x



(71) Snap hook 6x



(72) Low row chain



(73) Hand grip of cable arm 2x

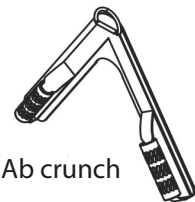

(74) Ab crunch



(75 & 75A) Foam pad with cover 6x

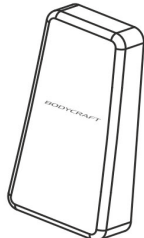

(76) Back pad



(77) Seat pad

## 2.3 Assembly: Multi-gym

Before assembly, take a close look at the individual assembly steps shown and carry out the assembly in the order given.

### **① NOTICE**

First loosely screw all parts together and check that they fit properly. Tighten the screws using the tool only when you are instructed to do so.

### **Step 1: Assembly of the Main Frame**

1. Mount the rear stabilizer (2) to the base frame (1) with two bolts (88), four washers (101) and two nuts (107).
2. Mount the front stabilizer (10) and the low row connector (13) to the base frame (1) with two bolts (85) and two nuts (106).
3. Attach one cap (40) to each end of the front and rear stabilizers (10 & 2).
4. Stick four non slips (70) to both sides of the foot plate (14) and mount the foot plate (14) to the low row connector (13) by aligning the holes and inserting the foot plate roller (15).
5. Insert one plug (46) into each end of the foot plate roller (15).
6. Mount the rear upright (3) to the rear stabilizer (2) with two washers (100) and two nuts (106).
7. Mount the front upright (4) to the base frame (1) with two bolts (88), four washers (101) and two nuts (107).
8. Mount the top frame (5) to the front upright (4) with two bolts (84) and two nuts (106).
9. Mount the top frame (5) to the rear upright (3) with two bolts (85) and two nuts (106).
10. Insert four plastic guide rod holders (47) into the base frame (1) and into the top guide rod retainer (7).
11. Insert the guide rods (6) into the guide rod holders (47).

### **① NOTICE**

If you have 14 weight plates (fig. 2), the weight stack spacers (130) must be installed (fig. 2). If you have 19 weight plates, discard the weight stack spacers (130) (fig. 1).

12. Slide one weight stack spacer (130) and one rubber donut (63) over each of the guide rods (6).
13. Carefully slide each of the 10 LB weight plates (68) over the guide rods (6) one by one. Make sure that all weight plates are facing forwards with the hole at the bottom.
14. Mount the selector rod (69) to the top plate (67) with the top plate bolt (109). Carefully slide the top plate (67) with the selector rod (69) over the guide rods (6).
15. Insert the magnetic selector pin (54) into the weight stack.
16. Mount the top frame connector (5A) to the top frame (5) with two bolts (85A) and two washers (100).
17. Slide the top guide rod retainer (7) over the guide rods (6) and mount the top guide retainer (7) to the top frame connector (5A) with two bolts (89), four washers (101) and two nuts (107).
18. Attach a plug (41) to the rear upright (3) and one plug (43) to the rear side of the top frame (5).

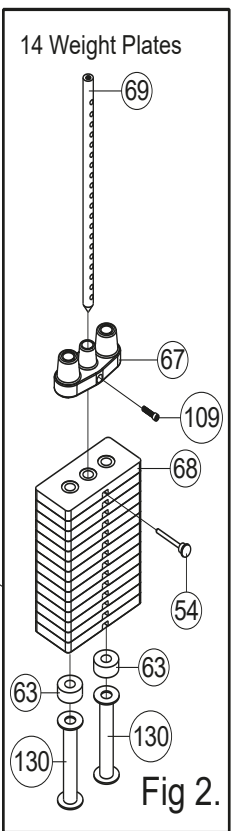
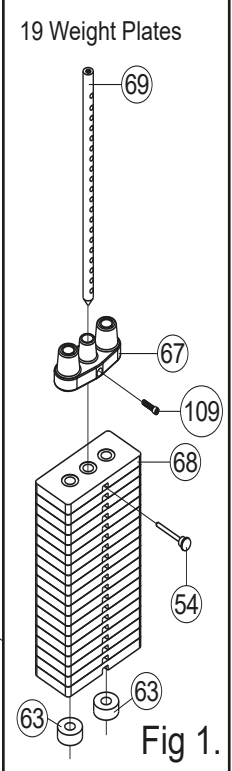
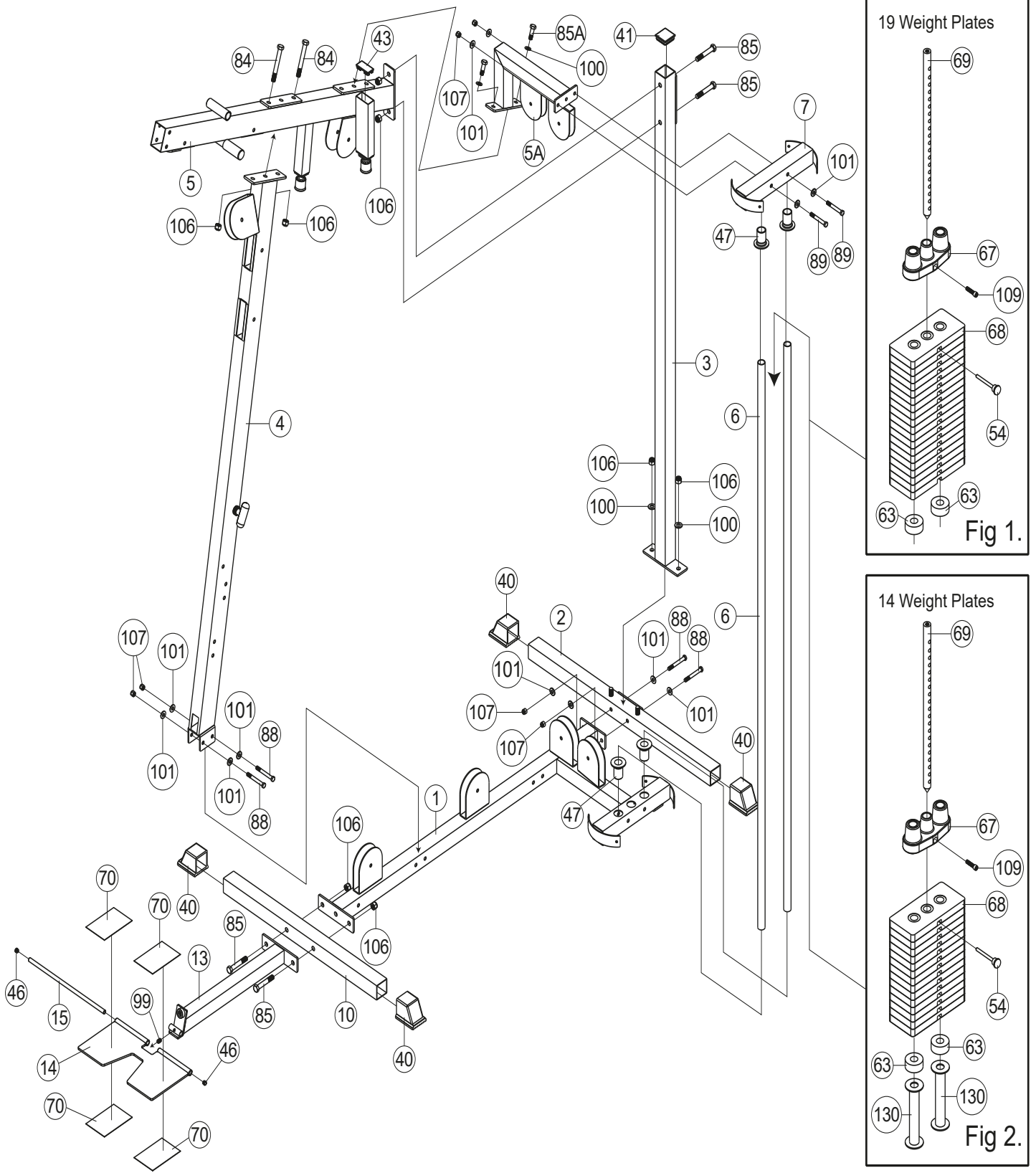

## Step 2: Assembly of the Press Arm and Cable Arm Assembly

1. Mount the press arm selector (8) to the top frame (5) by aligning the holes and inserting the axle (31A), locking it into place with the pre-set screw.
2. Mount the press arm (9) to the press arm selector (8) by aligning the holes and inserting the pivot axle (31), locking it into place with the pre-set screw.
3. Attach one plug (41A) to each end of the press arm (9) and one plug (41) to each end of the press arm selector (8).
4. Mount the cable arm connector (20A) to the cable arm assembly (20) with two bolts (93) and two washers (101).
5. Mount the cable arm connector (20A) to the front upright (4) and the base frame (1) with two bolts (88), four washers (101) and two nuts (107) each. Keep the bolts loosely tightened in order to align the holes easily.
6. Slide the axle of each cable arm (21) through the hole in the selector plate of the cable arm assembly (20) and fasten with the axle collar (36) and set screw (99). Ensure that the arms pivot freely and no cables are twisted.
7. Mount the lat bar holder (18) to the top frame (5) with two bolts (88), four washers (101) and two nuts (107).

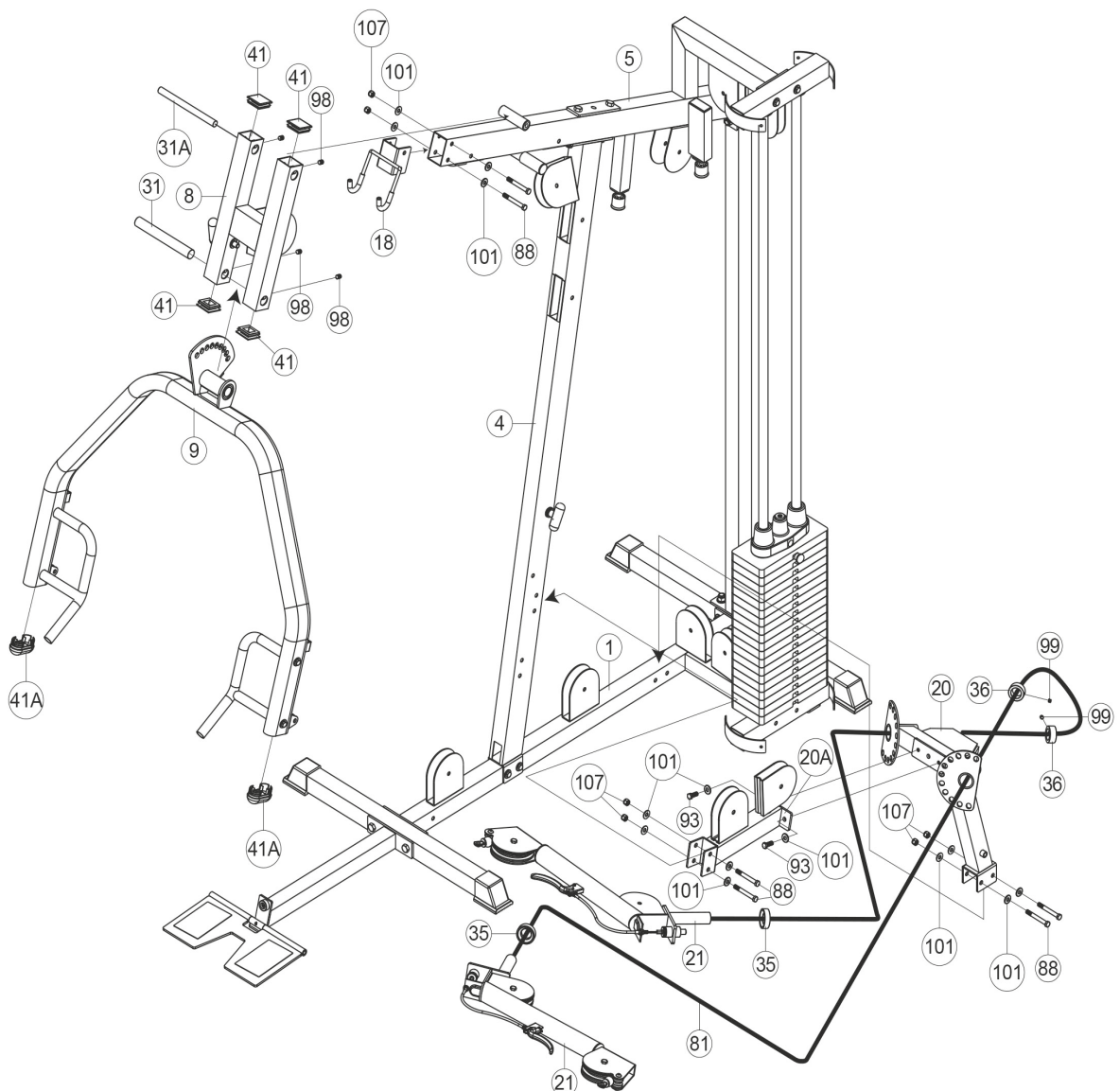

### Step 3: Assembly of the Seat and Back Frame

1. Mount the seat frame (11) to the front upright (4) with two bolts (88), four washers (101) and two nuts (107).
2. Mount the seat frame (11) to the base frame (1) with one bolt (87), two washers (101) and one nut (107).
3. Mount the leg extension arm (12) to the seat frame (11) by aligning the holes and inserting the leg extension axle (33). Fasten the leg extension axle (33) with two spring washers (104), two washers (102) and two set screws (97). Ensure that the leg extension arm (12) pivots freely.
4. Mount the right and left leg extension arms (12R & 12L) to the leg extension arm (12) with the set screw (98A).
5. Moisten the inside of the foam pads (75A) with water and attach one foam pad (75A) to each end of the right and left leg extension arms (12R & 12L). Fasten the foam pads (75A) with one plastic cover (45), one plastic washer (45A), one large washer (129) and one sunken head screw (116) each.

#### **NOTICE**

The L pin (55) is used to lock the leg extension arm (12) into place when using the low cable for exercises such as arm curls, leg kicks, upright rows etc. Remove the L pin (55) when performing leg extensions or leg curls.

6. Insert one foam roller bar (23) through the hole of the chromed seat adjuster (16). Moisten the inside of the foam pads (75A) with water and attach one foam pad (75A) to each end of the foam roller bar (23). Fasten the foam pads (75A) with one plastic cover (45), one plastic washer (45A), one large washer (129) and one sunken head screw (116) each.
7. Mount the seat pad (77) to the chromed seat adjuster (16) with two bolts (92) and two washers (101). Attach one plug (44) to the chromed seat adjuster (16). Insert the chromed seat adjuster (16) into the seat frame (11) and lock it into place with one spring (115) and the spring knob (53).
8. Mount the seat back adjuster (17) to the front upright (4) with one bolt (88), two washers (101) and one nut (107). It might be necessary to tighten and then loosen the bolt just enough so the seat back adjuster (17) pivots freely.
9. Insert the pop pin (51) for the seat back adjuster (17) into the front upright (4). Attach two metal hinges (19) to the top of the seat back adjuster (17) and then mount the back pad (76) to the metal hinges (19) with two bolts (93) and two washers (101).
10. Insert one foam roller bar (23) into the hole of the seat back adjuster (17). Moisten the inside of the foam pads (75A) with water and attach one foam pad (75A) to each end of the foam roller bar (23). Fasten the foam pads (75A) with one plastic cover (45), one plastic washer (45A), one large washer (129) and one sunken head screw (116) each. Lock into place with the pre-installed screw.
11. Mount the weight shrouds (28) to the base frame (1) and the top guide rod retainer (7) with four bolts (95) and four washers (102) each.
12. Attach two bindings of weight shroud (83) to each weight shroud (28).
13. Gradually tighten all bolts and nuts.



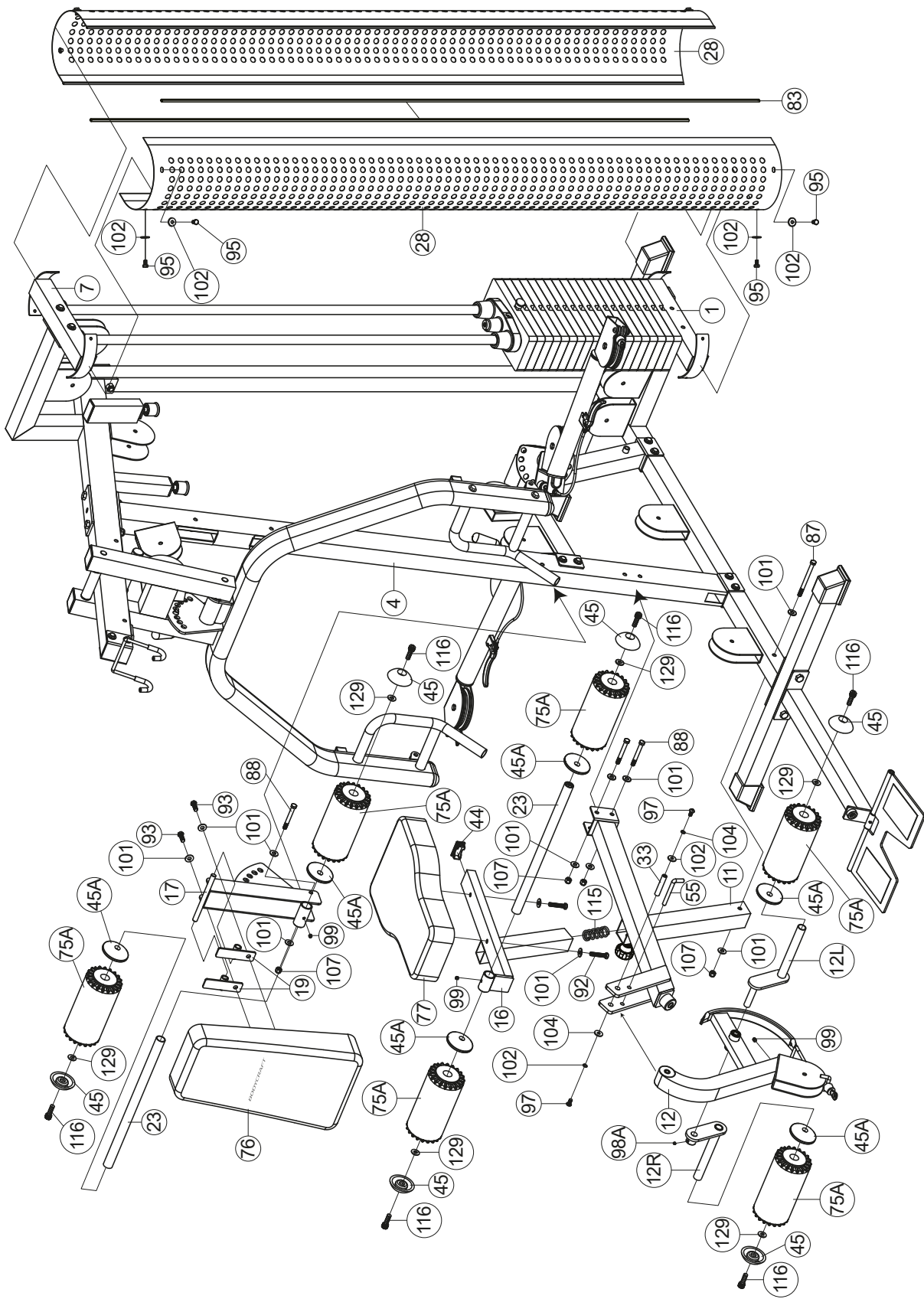

#### Step 4: Assembly of the Top Cable (4600mm)

► **ATTENTION**

During assembly, always place the cables over or under the pulleys and only then mount the covers. It is not always possible to pass the cables through afterwards!

Insert the threaded end of the top cable (80) into the slot in front of the top frame (5) [FIG1] and pass the cable as followed:

- + over the top pulleys in the top frame (5) [FIG1 & FIG2]
- + over the left pulley (as if sitting on the seat) in the press arm selector (8) [FIG3, STEP1]
- + under the pulley in the front upright (4)
- + over the right pulley in the press arm selector (8) [FIG3, STEP2]
- + over the pulley in the front upright (4) [FIG4]
- + down to the top pulley in the adjustable pulley block (25) [FIG5]
- + up and over the left pulley in the top frame (5) [FIG6]
- + down and around the top pulley in the adjustable pulley block (25) [FIG7]
- + up and over the two rear pulleys in the top frame connector (5A) facing the weight stack [FIG8]

Screw the cable end into the selector rod (69) [FIG9].

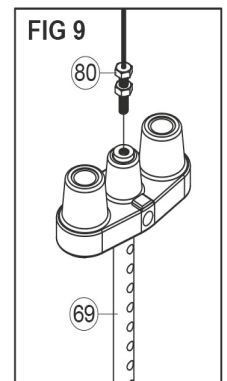
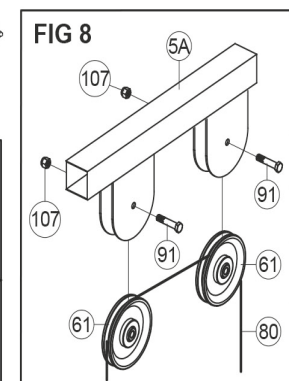
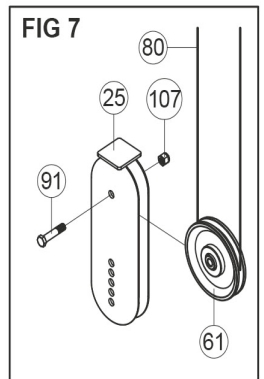
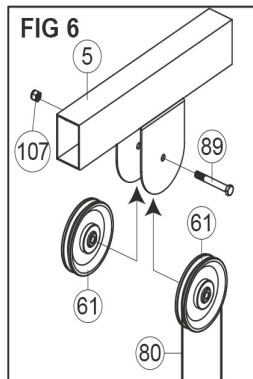
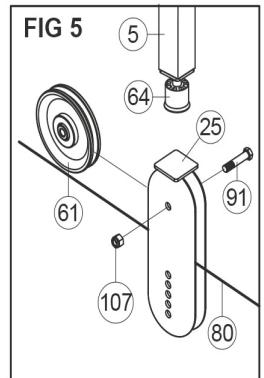
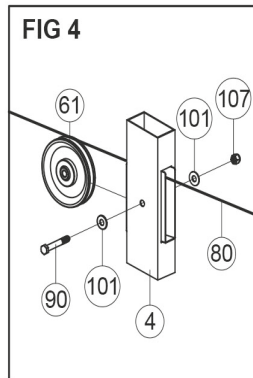
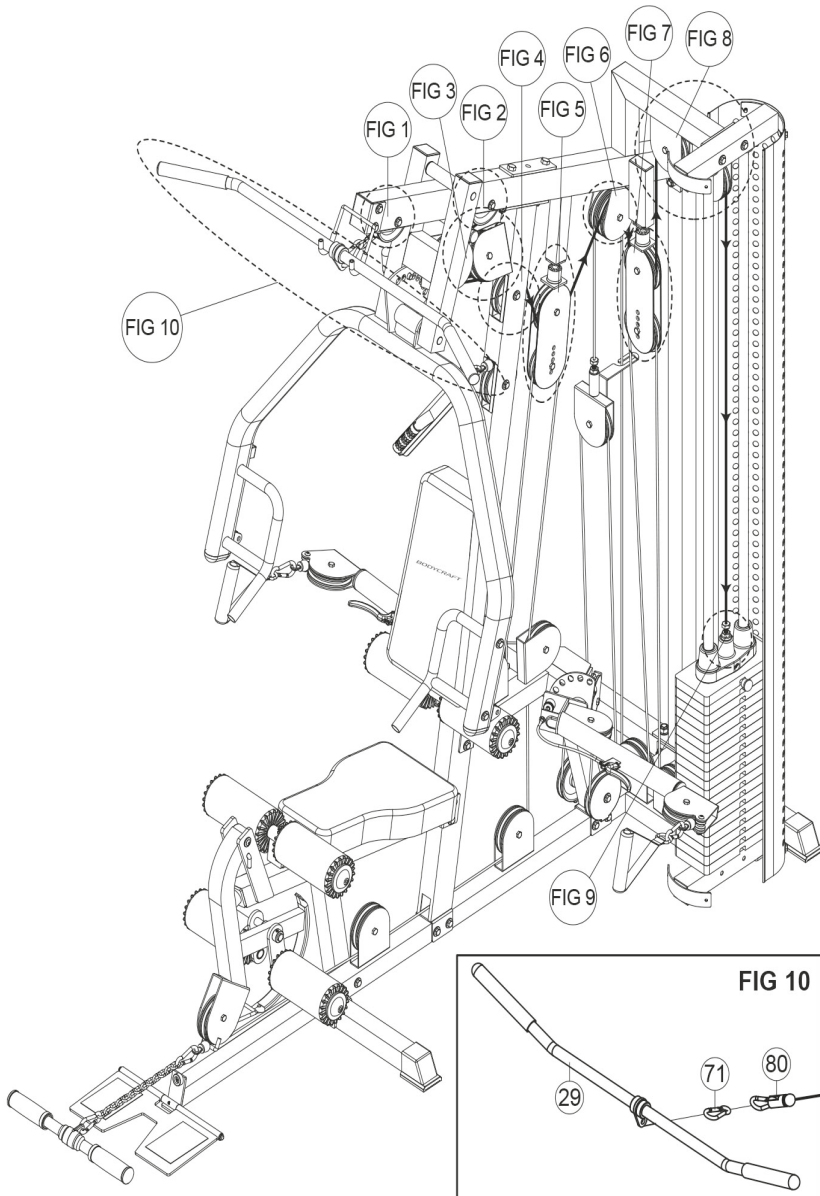
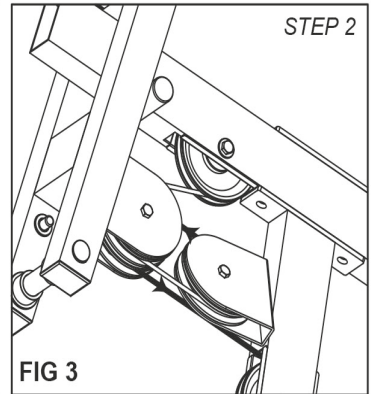
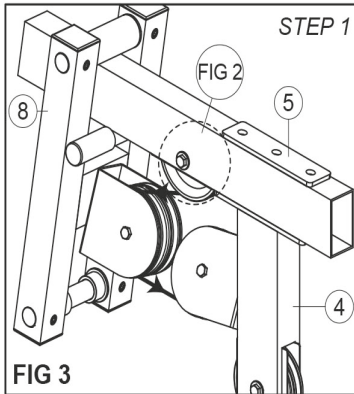
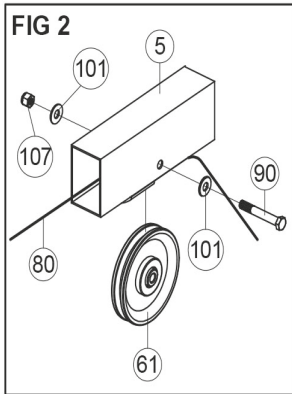
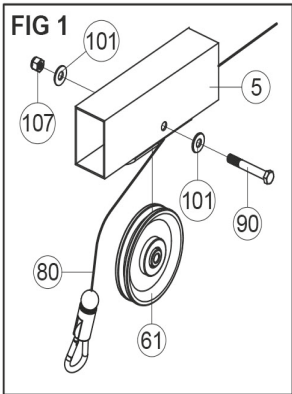

## Step 5: Assembly of the Ab Crunch Cable (4360mm)

### ► ATTENTION

During assembly, always place the cables over or under the pulleys and only then mount the covers. It is not always possible to pass the cables through afterwards!

Insert the ab crunch cable (78) through the slot in the front upright (4) and pass the cable as followed:

- + over the pulley in the front upright (4) [FIG1]
- + down to the front pulley on top of the cable arm connector (20A) [FIG2]
- + up and over the lower pulley in the adjustable pulley block (25) [FIG3]
- + down to the rear pulley on the cable arm connector (20A) [FIG4]
- + further to the rear pulley on the base frame (1) [FIG5 & FIG6]
- + forward to the leg extension arm (12). Ensure that the cable runs below both pulleys on the base frame (1) as well as the pulley on the leg extension arm (12).

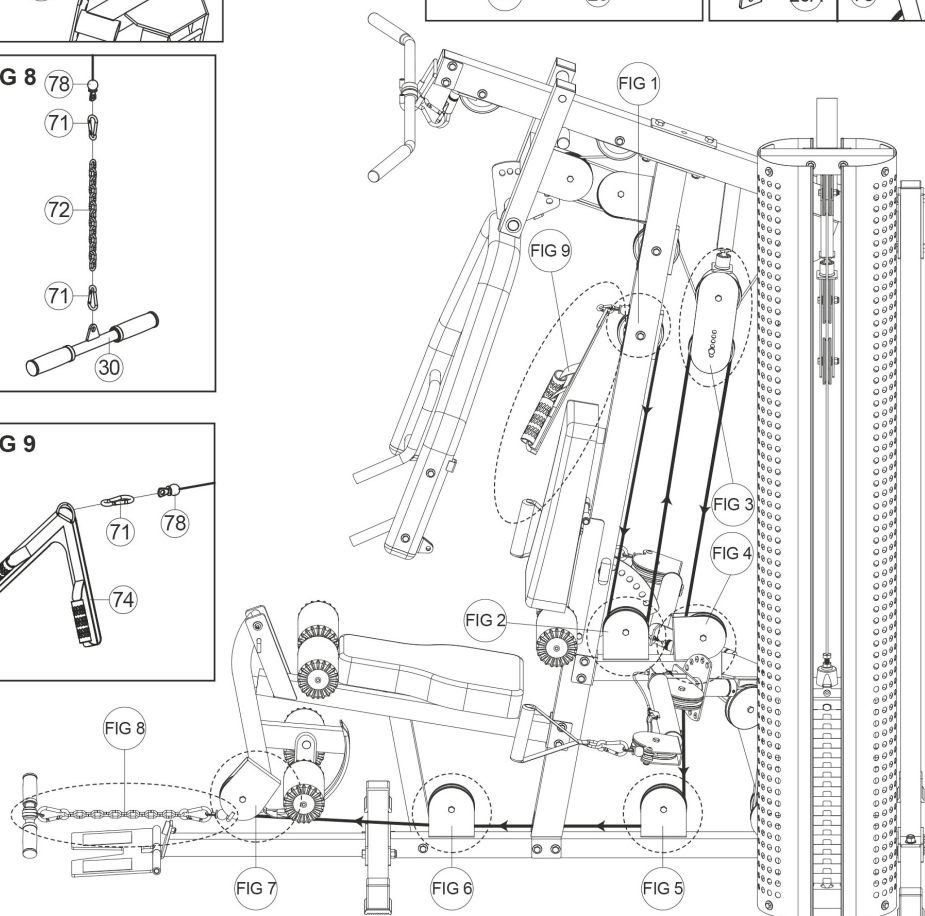
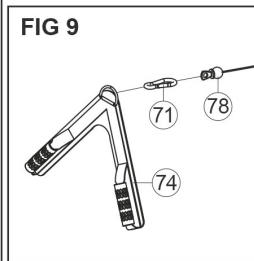
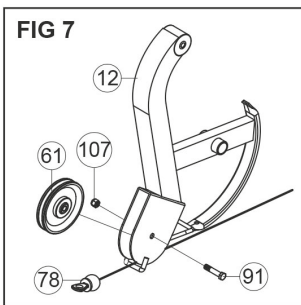
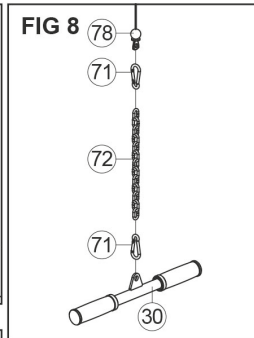
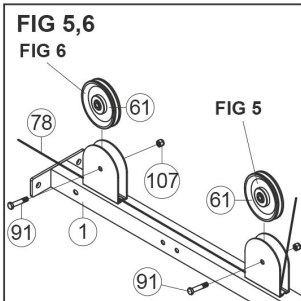
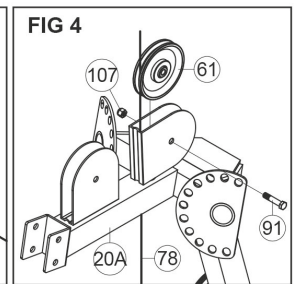
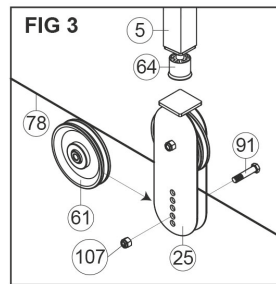
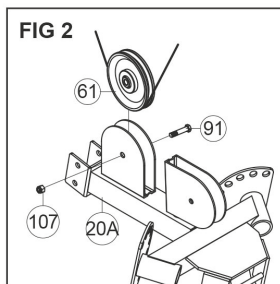
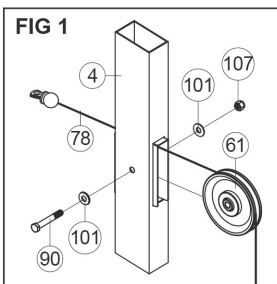

## Step 6: Assembly of the Cable Arm Connecting Cable (4700mm)

### ► ATTENTION

- + During assembly, always place the cables over or under the pulleys and only then mount the covers. It is not always possible to pass the cables through afterwards!
- + If you have purchased the optional leg press, do NOT use the cable arm connecting arm (4700mm), use the leg press cable instead.

Mount one pulley to the base frame (1) near the weight stack [FIG1]. The ball end of the cable must be facing towards the weight stack. Pass the cable as followed:

- + up and over the lower pulley of the adjustable pulley block (25) [FIG2]
- + down to the pulley on the base frame (1) [FIG3]
- + up and over the right pulley on the top frame (5) [FIG4].

Screw the threaded end of the cable into the single pulley block (27) [FIG5].

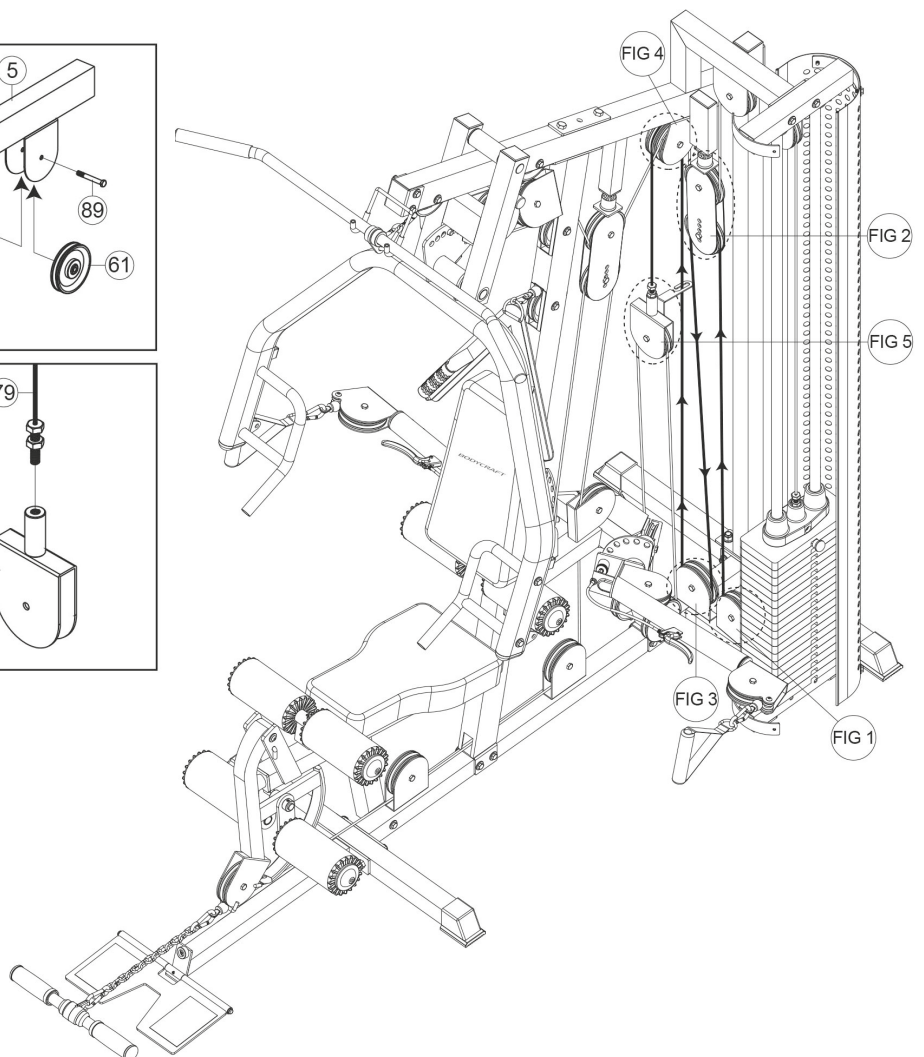
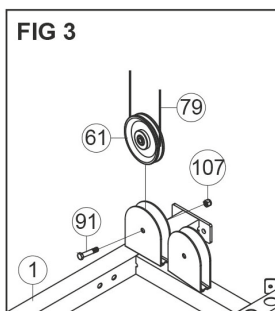
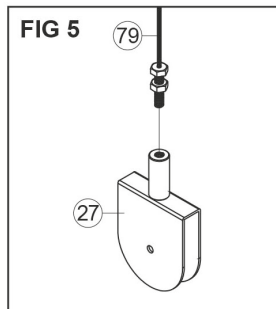
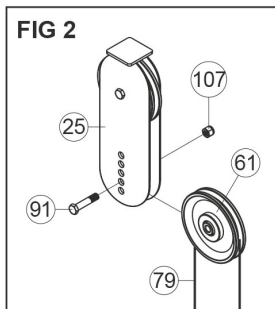
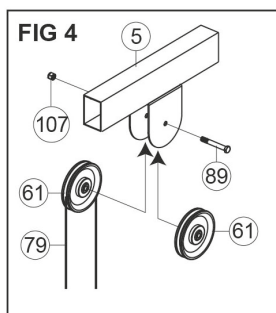
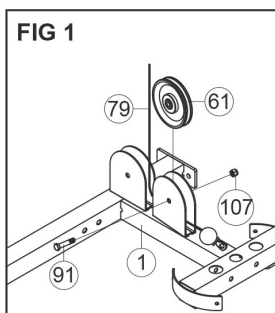

## Step 7: Assembly of the Cable Arm Cable (5410mm)

### ► ATTENTION

During assembly, always place the cables over or under the pulleys and only then mount the covers. It is not always possible to pass the cables through afterwards!

Mount one pulley and the pulley guide bracket (24) to the cable arm assembly (20) [FIG2 & FIG3]. Ensure that the pulley guide bracket does not interfere with the cable movement when tightened. Pass the cable (81) around the pulley on the base frame (1) [FIG4] and up and over the pulley in the single pulley block (27) [FIG5].

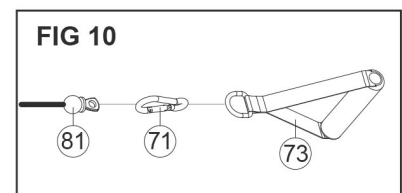
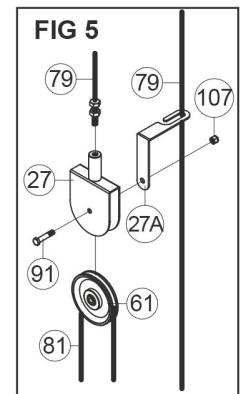
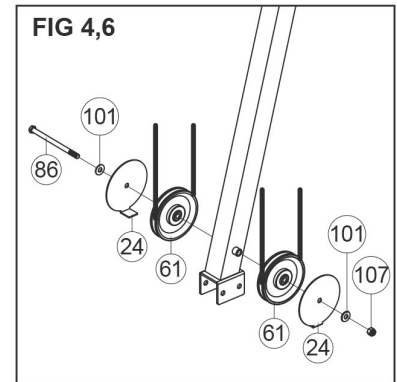
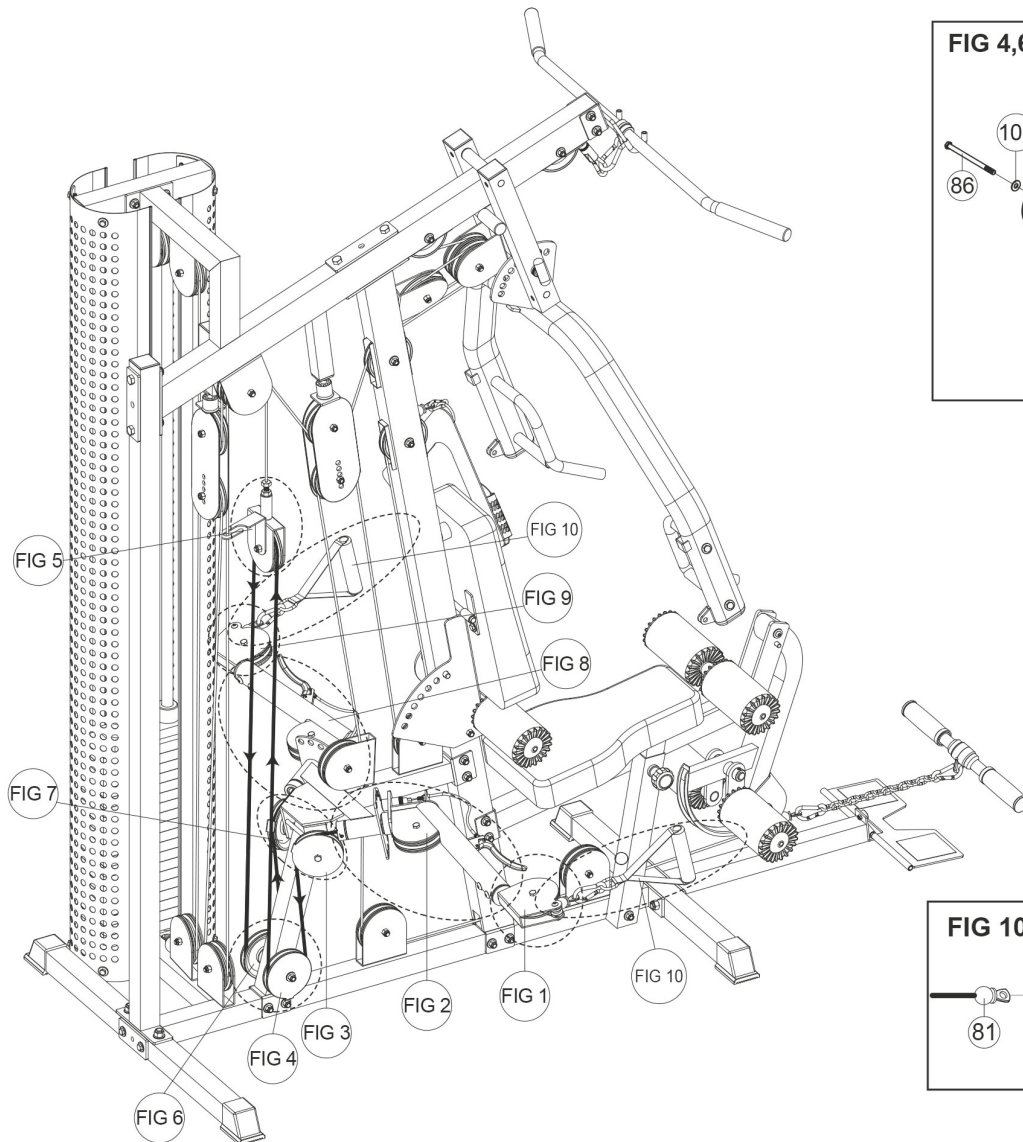
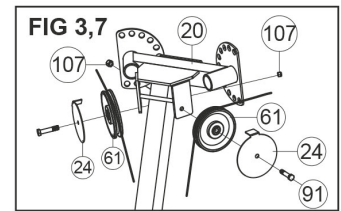
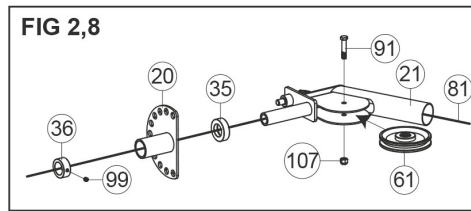
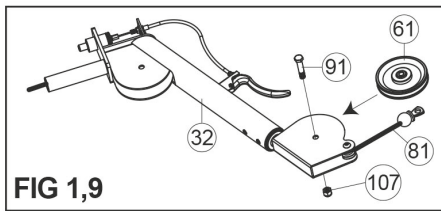

## Step 8: Cable Adjustment

The cables should be tightened to the point just before the top plate lifts off the weight stack. If the top plate is not resting on the weight stack, you must add length. If the cables are slacking, you must shorten the length. There are several adjustment points, depending on whether only minor or larger adjustments are needed.

### Minor Adjustments

For minor adjustments, you can adjust the screw ends on the top cable (at the top plate) and the cable arm connecting cable (where it screws into the pulley block). Once adjusted, lock them into place with the jam nuts.



### CAUTION

These ends must always be screwed in at least 1/3 of their length.

### Coarse Adjustments

Coarse adjustments are made at the adjustable pulley block (25). Move the bottom pulley towards the center to decrease/tighten the length. Move the bottom pulley downwards to increase/loosen the length.

Once the cables have been adjusted to remove all slack, adjust the adjustable stoppers in the top frame to the point where they just touch the adjustable pulley block (25).

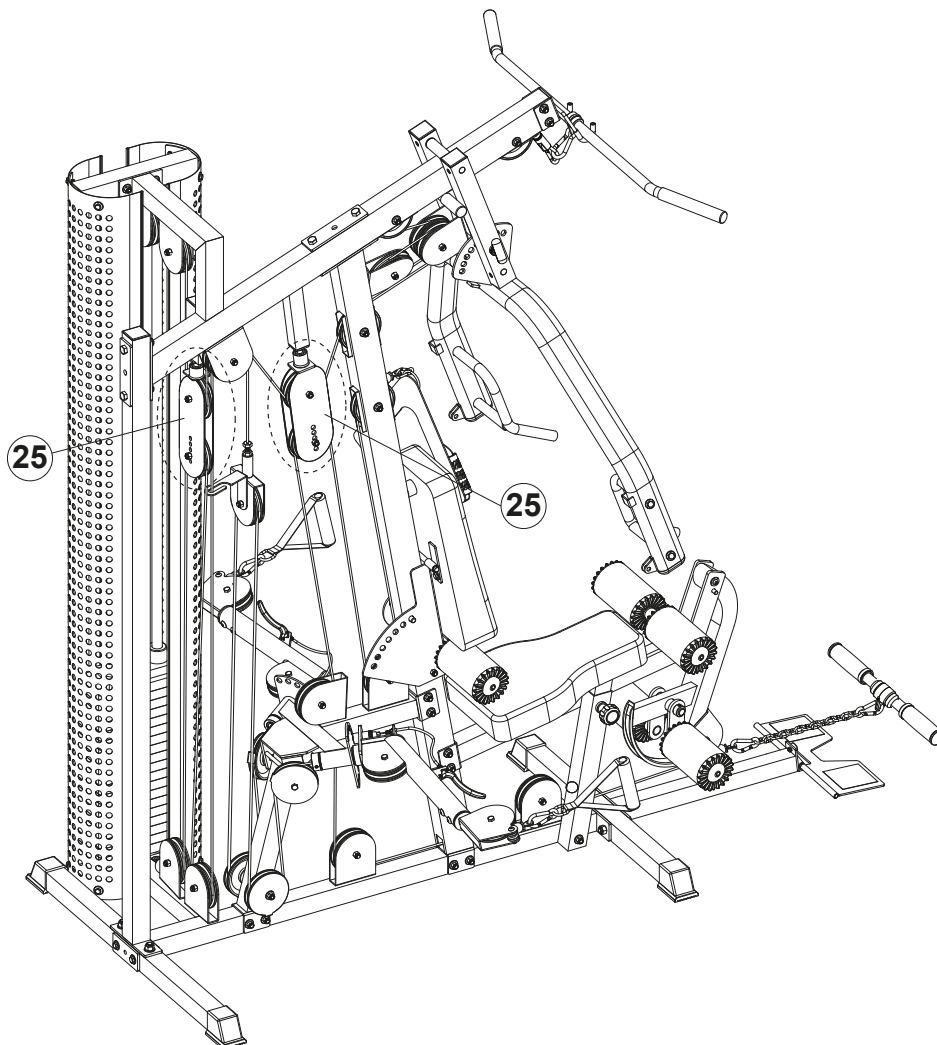

## 2.4 Scope of Delivery: Leg Press

The scope of delivery consist of the following parts. At the beginning, check whether all parts and tools belonging to the device are included in the scope of delivery and whether damage has occurred. In the event of complaints, the contractual partner must be contacted directly.

**⚠ CAUTION**

If parts of the scope of delivery are missing or damaged, the assembly must not be carried out.

**📌 NOTICE**

The BodyCraft Xpress Pro leg press is an optional accessory for the Xpress Pro multi-gym. The leg press is not included in the scope of delivery of the multi-gym and must be purchased separately.

NO.	DESCRIPTION	QTY.
227	1/2" X 4-1/4" HEX BOLT	2
228	1/2" X 3/4" HEX THREADED BOLT	4
229	3/8" X 4" HEX BOLT	2
230	3/8" X 3-1/2" HEX BOLT	1
231	3/8" X 3" HEX BOLT	5
232	3/8" X 1-3/4" HEX BOLT	2
233	3/8" X 2-3/4" HEX THREADED BOLT	1
234	3/8" X 1" HEX THREADED BOLT	4
236	1/2" WASHER	8
237	3/8" WASHER	17
238	1/2" NYLON NUT	2
239	3/8" NYLON NUT	9

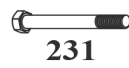
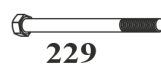



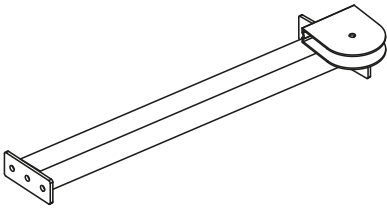

**(201) BASE STABILIZER**

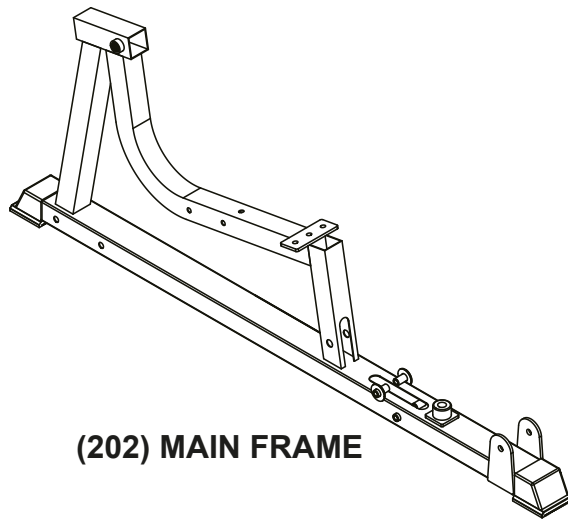

**(202) MAIN FRAME**

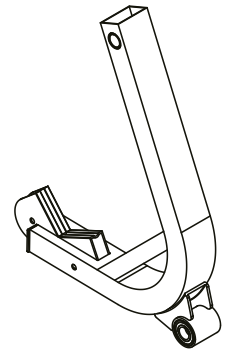

**(203) LEG PRESS SUPPORT**

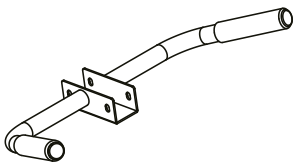

**(204) SEAT HANDLE**

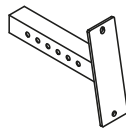

**(205) BACK PAD ADJUSTER**

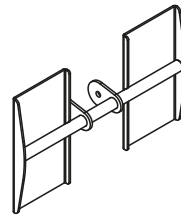

**(206) FOOT PLATE**

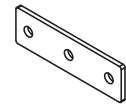

**(207) CONNECTOR STEEL PLATE**



**(208)  $\phi$ 25mm AXLE**



**(209)  $\phi$ 3/4" AXLE**



**(210) COLLAR X 2pcs**



**(212) NON SLIP X 2pcs**



**(213) BACK PAD**

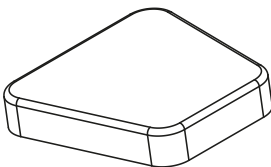

**(214) SEAT PAD**



**(215) 114mm PULLEY**



**(216) 90mm PULLEY X 4pcs**

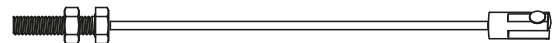

**(217B) LEG PRESS CABLE**



**(218) LOCKING SPRING KNOB**

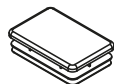

**(219) 50 X 75mm RECT. PLUG**



**(224) LEG PRESS BUSHING X 2pcs**

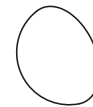

**(240) CAP FOR NUT X 4pcs**

## 2.5 Assembly: Leg Press

Before assembly, take a close look at the individual assembly steps shown and carry out the assembly in the order given.

### **i** NOTICE

First loosely screw all parts together and check that they fit properly. Tighten the screws using the tool only when you are instructed to do so.

### Step 1: Assembly of the Base Stabilizer

Attach the base stabilizer (201) to the base frame of the multi-gym (1) with two bolts (231), four washers (237) and two nylon nuts (239).

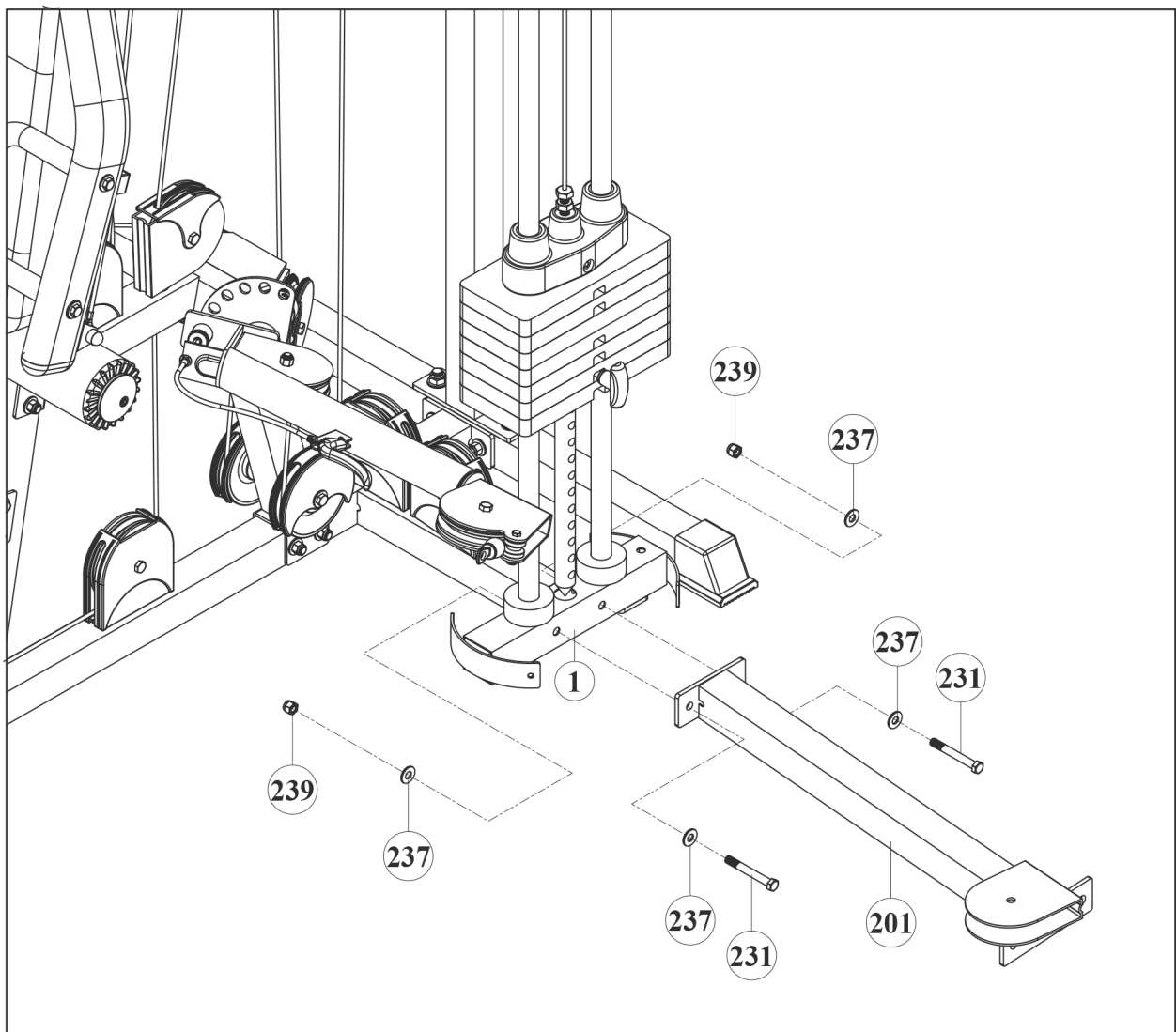

## Step 2: Assembly of the Main Frame and Leg Press Support

1. Attach the main frame (202) to the base stabilizer (201) with two bolts (227), four washers (236), one connector steel plate (207) and two nuts (238).
2. Attach the plug (219) to the leg press support (203).
3. Insert the 25mm axle (208) into the leg press support (203), then attach the leg press support (203) to the main frame (202) with two collars (210) [inside the brackets on the main frame], two bolts (228) and two washers (236). Tighten the bolts (228) and cap with two end caps (240).
4. Insert the 3/4" axle (209) into the upper hole of the leg press support (203), then attach the foot plate (206) to the leg press support (203) with two bolts (228) and two washers (236). Tighten the bolts (228) and cap with two end caps (240).
5. Attach two non slips (212) to the foot plate (206).

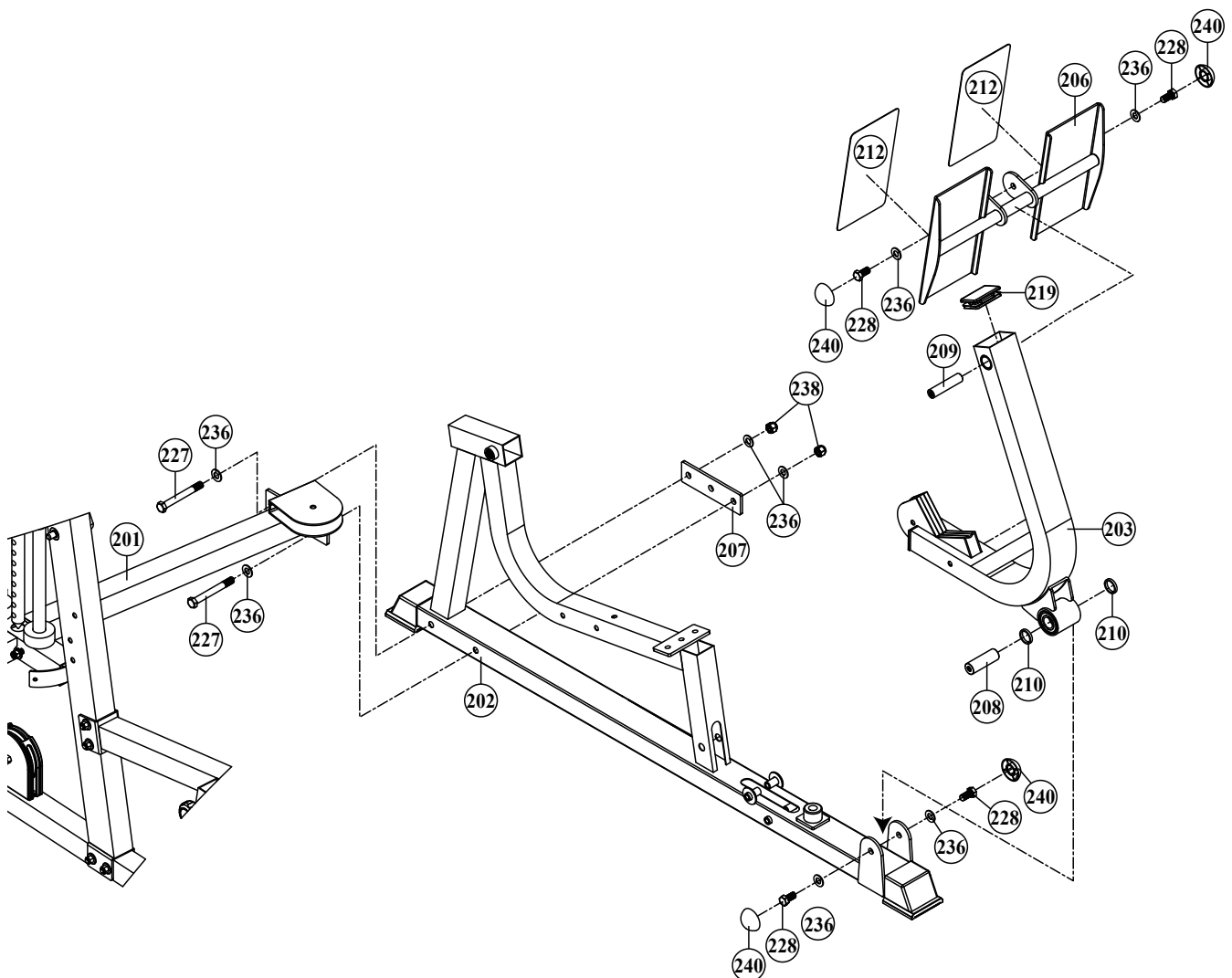

### Step 3: Assembly of the Seat Handle and the Pads

1. Attach the seat handle (204) to the main frame (202) with two bolts (231), four washers (237) and two nuts (239).
2. Attach the seat pad (214) to the main frame (202) with one bolt (233), two bolts (234) and three washers (237).
3. Attach the back pad (213) to the back pad adjuster (205) with two bolts (234) and two washers (237).
4. Slide the back pad adjuster (205) into the main frame (202) and lock it into place with the spring knob (218).



#### CAUTION

Make sure the spring knob (218) always engages in one of the adjustment holes when adjusting the position.

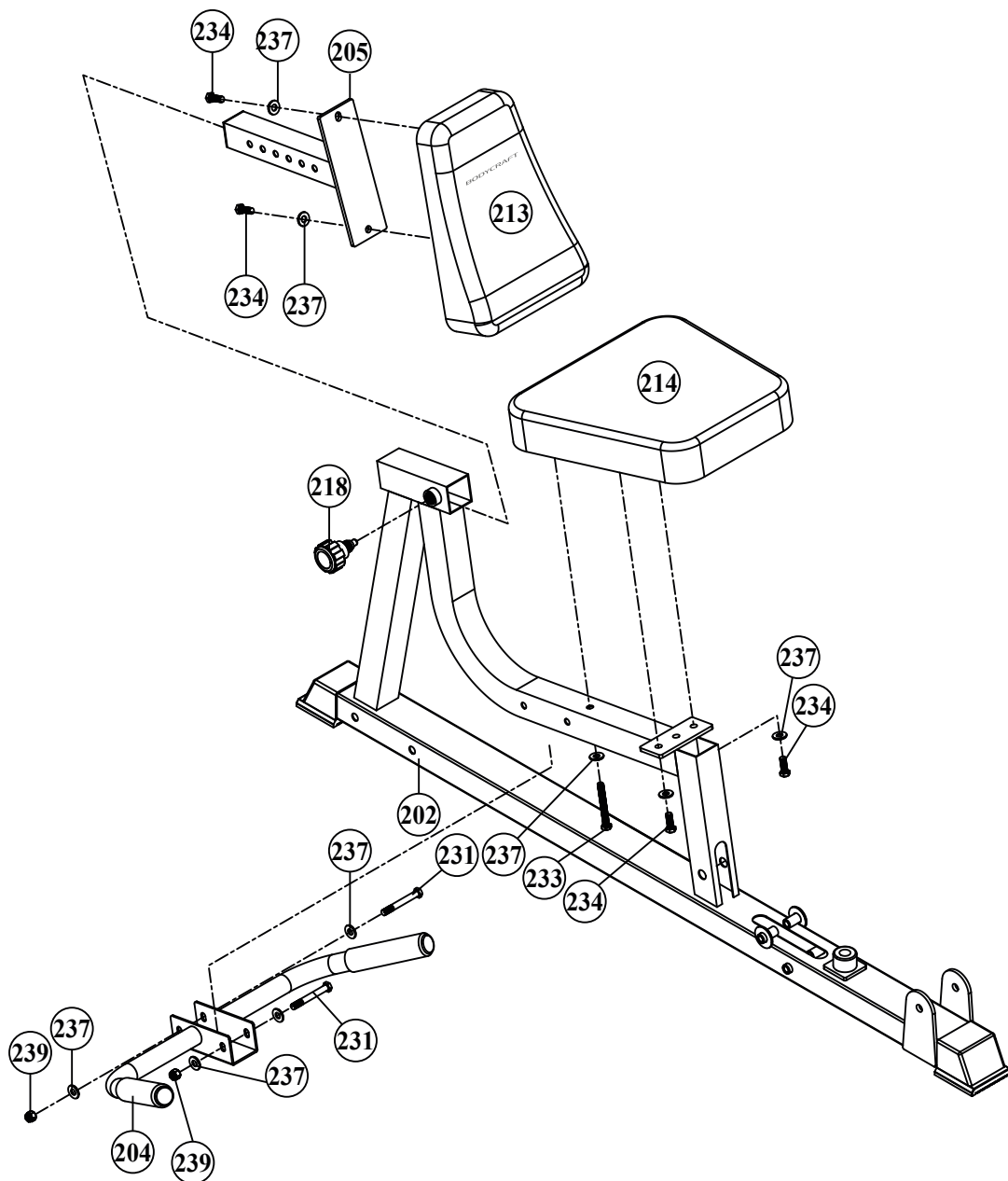

## Step 4: Assembly of the Leg Press Cable, Part 1

### NOTICE

The cable and pulleys must be assembled simultaneously as you go. If some pulleys have previously been assembled, you might need to loosen them first.

1. If mounted, screw the threaded end of the cable arm connecting cable (79) from the single pulley block (27) and remove the cable (79) [from the multi-gym].
2. Screw the threaded end of the leg press cable (217B) halfway into the single pulley block (27) [Fig. 1].
3. Route the cable (217B) up and over the right sided pulley (61) in the top frame (5) and mount both pulleys (61) like shown with one bolt (89) and one nut (107) [Fig. 2].

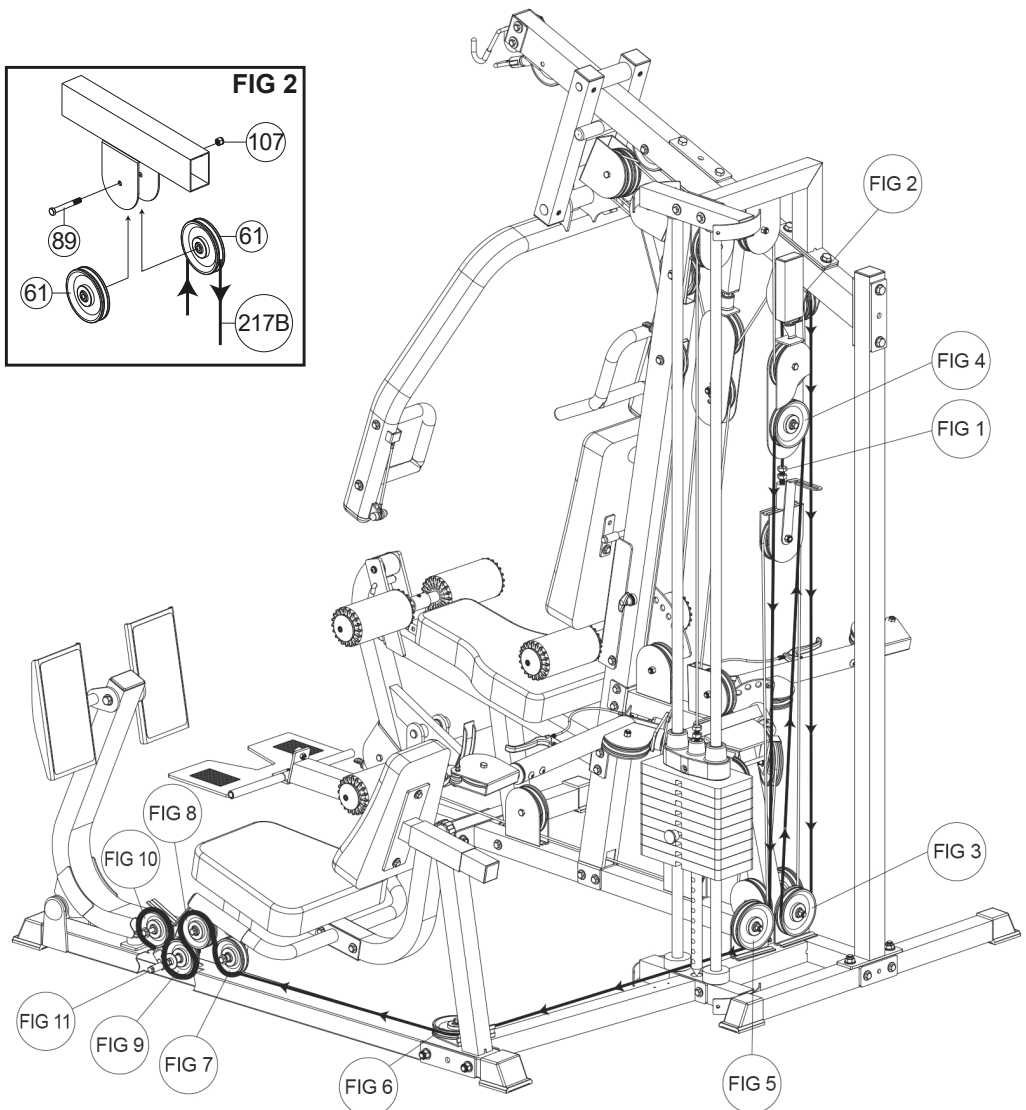
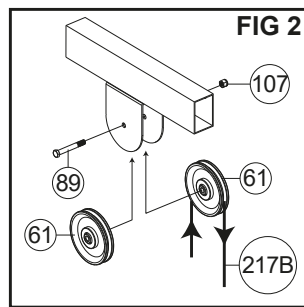
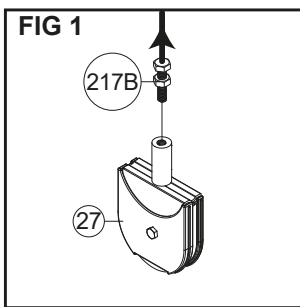

## Step 5: Assembly of the Leg Press Cable, Part 2

### **i** NOTICE

The cable and pulleys must be assembled simultaneously as you go. If some pulleys have previously been assembled, you might need to loosen them first.

1. Route the cable (217B) down and under one pulley (61) and attach the pulley (61) to the base frame (1) with one bolt (91) and one nut (107) [Fig. 3].
2. Route the cable (217B) up and over the lower pulley (61) in the adjustable pulley block (25) and attach the pulley (61) to the middle hole with one bolt (91) and one nut (107) [Fig. 4].

### **i** NOTICE

The multiple holes in the adjustable pulley block (25) can be used for cable adjustment once the cable is completely assembled.

3. Route the cable (217B) down and under one pulley (61) and attach the pulley (61) to the base frame (1) with one bolt (91) and one nut (107) [Fig. 5].

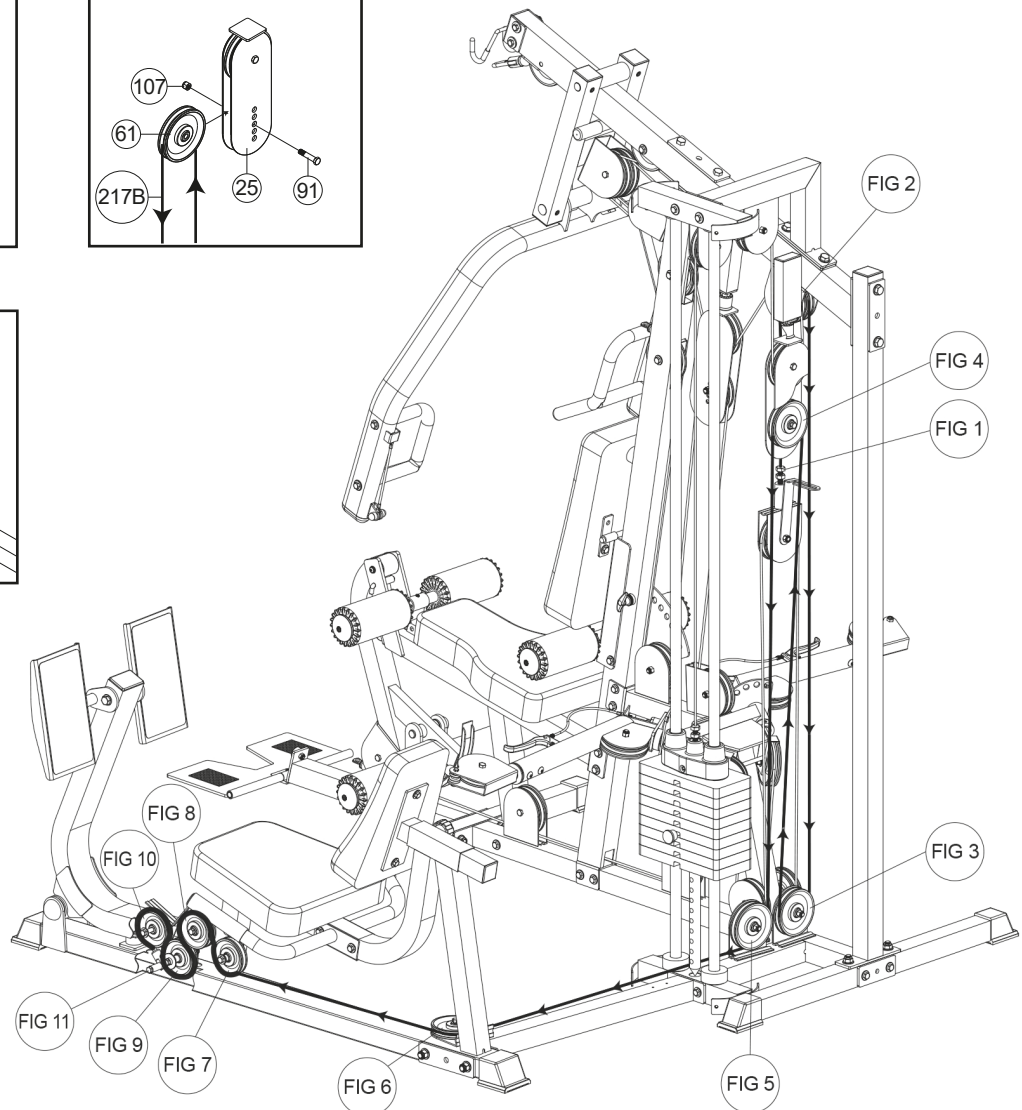
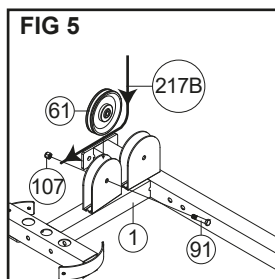
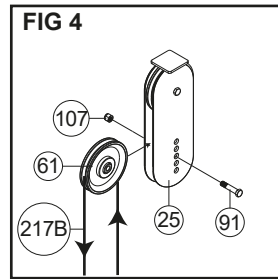
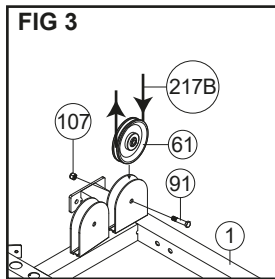

## Step 6: Assembly of the Leg Press Cable, Part 3

### NOTICE

The cable and pulleys must be assembled simultaneously as you go.

1. Continue routing the cable (217B) underneath the weight stack and around the 114mm pulley (215) and attach the pulley (215) to the leg press main frame (202) with one bolt (232) [Fig. 6].
2. Route the cable (217B) under one pulley (216) and attach the pulley (216) to the main frame underneath the seat (202) with one bolt (231), two leg press bushings (224), two washers (237) and one nut (239) [Fig. 7].
3. Route the cable (217B) over one pulley (216) and attach the pulley (216) to the outer pulley bracket on the leg press support (203) with one bolt (232) and one nut (239) [Fig. 8].

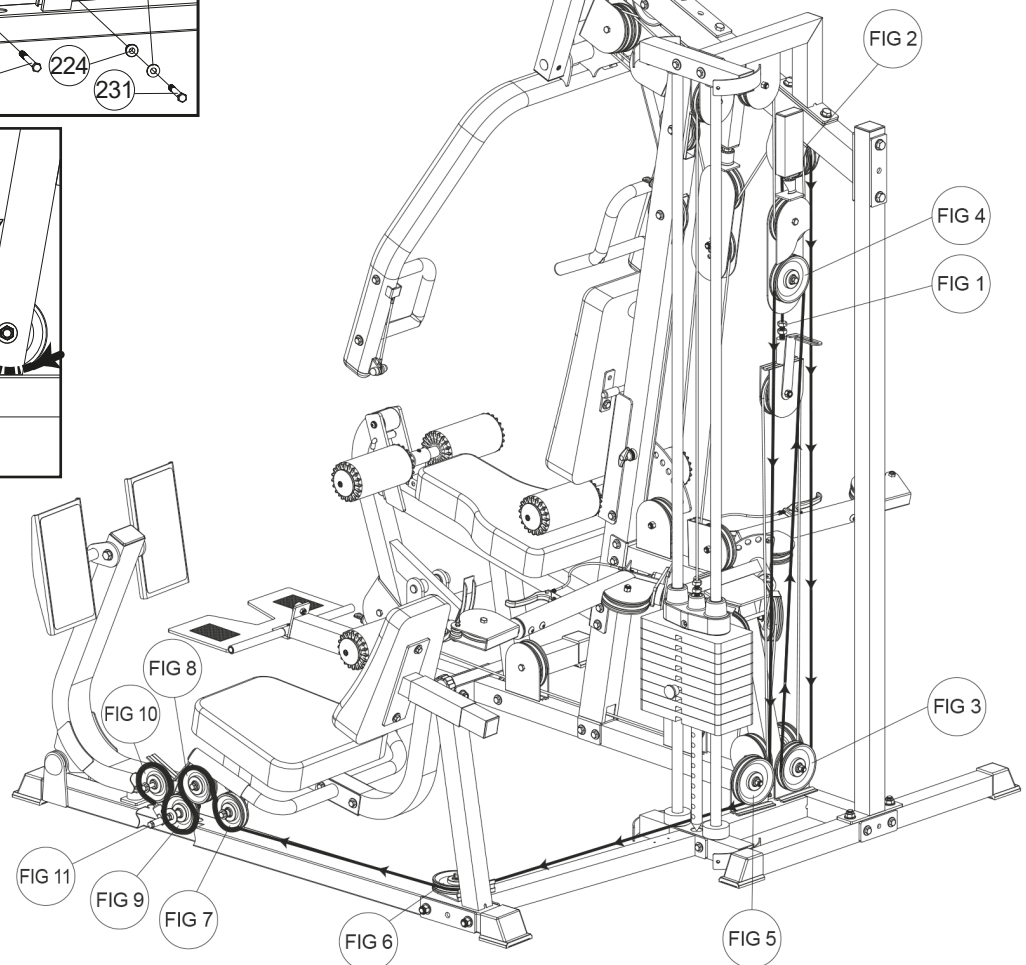
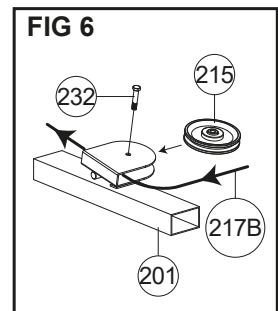
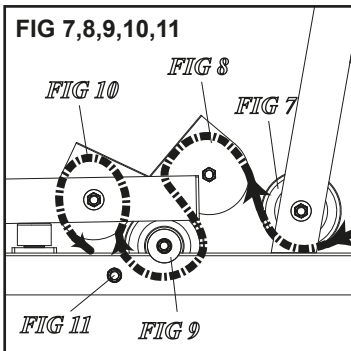
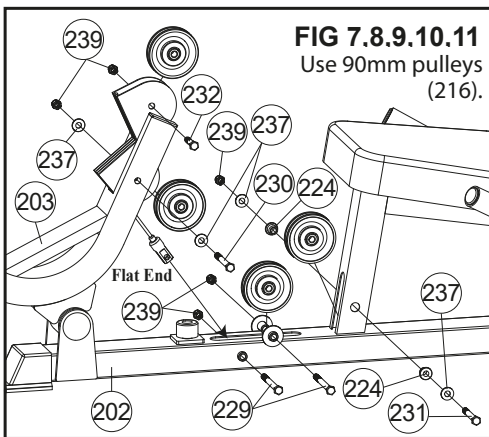

## Step 7: Assembly of the Leg Press Cable, Part 4

### **NOTICE**

The cable and pulleys must be assembled simultaneously as you go.

1. Route the cable (217B) under one pulley (216) and attach the pulley (216) to the main frame (202) with one bolt (229) and one nut (239) [Fig. 9].
2. Route the cable (217B) over one pulley (216) and attach the pulley (216) to the inner pulley bracket on the leg press support (203) with one bolt (230), two washers (237) and one nut (239) [Fig. 10].
3. Attach the flat end of the cable (217B) to the main frame (202) with one bolt (229) and one nut (239).
4. If needed, adjust the cable length with the lower pulley in the adjustable pulley block (25) [Fig. 4].
5. Tighten all bolts and nuts.

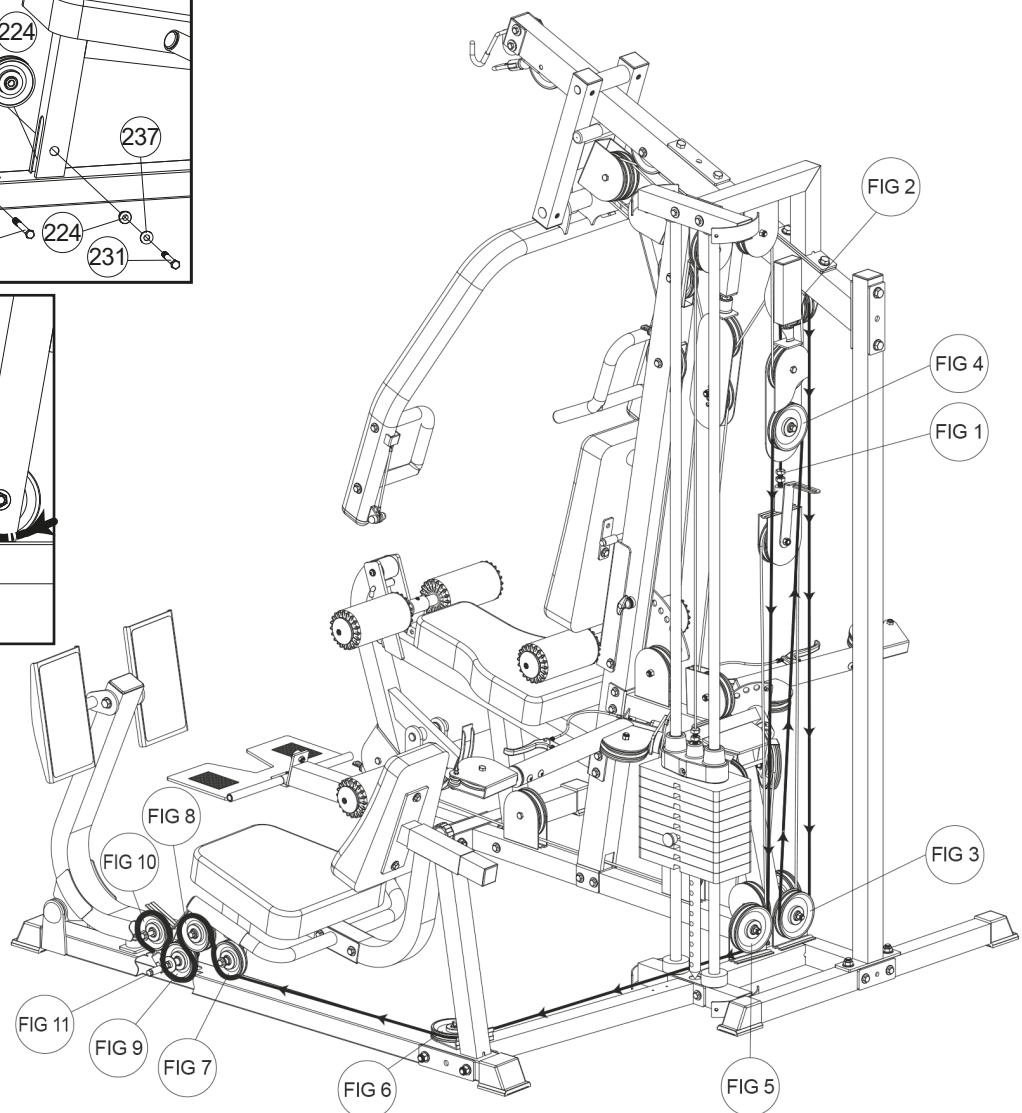
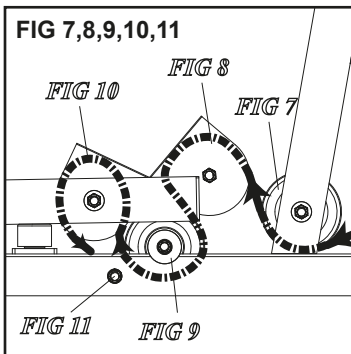
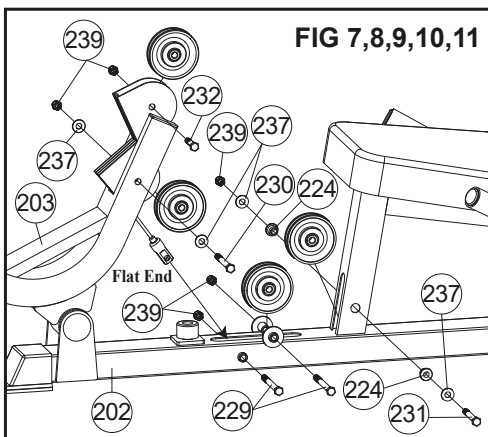



### 3.1 General Instructions

▶ **ATTENTION**

- + Make sure that the equipment is protected from moisture, dust and dirt in the selected storage location. The storage location should be dry and well ventilated and have a constant ambient temperature between 5°C and 45°C.

 **WARNING**

- + The storage location should be chosen so that improper use by third parties or children can be prevented.
- + If your equipment does not have transportation wheels, the equipment must be disassembled before transportation.

## 4.1 General Instructions



### WARNING

- + Do not make any improper changes to the equipment.



### CAUTION

- + Damaged or worn components may affect your safety and the life of the equipment. Therefore, immediately replace damaged or worn components. In such a case, contact the contract partner. The equipment must not be used until it has been repaired. If necessary, use only original spare parts.

### ▶ ATTENTION

- + In addition to the instructions and recommendations for maintenance and care given here, additional service and/or repair work may be necessary; this must only be carried out by authorised service technicians.

## 4.2 Faults and Fault Diagnosis

The equipment undergoes regular quality controls during production. Nevertheless, faults or malfunctions may occur. Frequently, individual parts are responsible for these disturbances, an exchange is usually sufficient. Please refer to the following overview for the most common errors and how to correct them. If the equipment still does not function properly, contact your contract partner.

Fault	Cause	Solution
Grinding noises	Cables or pulleys do not run smoothly or are damaged	+ Visual inspection of the cable routing or the pulley guide + If damaged, replace the defective part
Weight hanging in the air	Cable tensioned too tight	Readjust cable tension
Cable without tension	Cable too loose	+ Check cable routing + Readjust cable tension
Squeaking & cracking noises	Screw connections loosened or too tight	+ Check or lubricate screw connections* + Check cable routing
Unit wobbles	+ Uneven ground + Loose screw connections	+ Align unit + Tighten screw connections
Heavy draught	+ Weight holders/guide rods too dry + Faulty cable routing	+ Lubricate guide rods* + Check cable routing

\* With a grease-free silicone oil or silicone spray.

### 4.3 Maintenance and Inspection Calendar

To avoid damage from body sweat, the equipment must be cleaned with a damp towel (no solvents!) after each training session.

The following routine tasks must be performed at the specified intervals:

Part	Weekly	Monthly	Quarterly	Half-yearly	Yearly
Cables and pulleys	C/I				
Bolt connections		I			
Pulleys and cables	I				
C = clean; I = inspect					

## 5 DISPOSAL

At the end of its operational life, this equipment cannot be disposed of in normal household waste. Instead, it must be disposed of via an electricals recycling centre. Further information can be obtained from your local authority's recycling service.

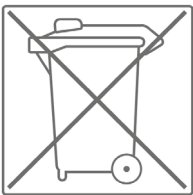

The materials can be recycled as per their symbols. Through the reuse, recycling of materials or other forms of recovery of old equipment, you make an important contribution to the protection of the environment.

## 6 RECOMMENDED ACCESSORIES

To make your training experience even more efficient and pleasant, we recommend that you add suiting accessories to your fitness equipment. For training equipment like smith machines, weight benches or racks this could for example be a **floor mat**, which makes your fitness equipment stand more securely and also protects the floor from sweat but it could be also **additional weights**, **handles**, **foot straps** for leg exercises or **triceps ropes**. For some smith machines, there are also optional add-ons such as **leg presses** that make your workout even more intense and comprehensive.

Our range of accessories offers the highest quality and makes training even better. If you would like to find out more about compatible accessories, please go to the detail page of the product in our webshop (the easiest way is to enter the article number in the search field above) and go to the recommended accessories on this page. Alternatively, you can use the QR code provided. Of course, you can also contact our customer service: by telephone, e-mail, in one of our branches or via our social media channels. We will be happy to advise you!



floor mat



chest strap



triceps rope



weight block extension

## 7.1 Serial Number and Model Name

In order to provide you with the best possible service, please have the model name, article number, serial number, exploded drawing and parts list ready. The corresponding contact options can be found in chapter 9 of this operating manual.

**① NOTICE**

The serial number of your equipment is unique. It's located on a white sticker.

Enter the serial number in the appropriate field.

**Serial number:**

**Brand / Category:**

**Model Name:**

**Article Number:**

## 7.2 Parts List: Multi-gym

No.	Name	Qty.
1	BASE FRAME	1
2	REAR STABILIZER	1
3	REAR UPRIGHT	1
4	FRONT UPRIGHT	1
5	TOP FRAME - bearing pre-installed	1
5A	TOP FRAME CONNECTOR	1
6	GUIDE ROD	2
7	TOP GUIDE ROD RETAINER	1
8	PRESS ARM SELECTOR	1
9	PRESS ARM	1
9R	RIGHT HANDLE OF PRESS ARM	1
9L	LEFT HANDLE OF PRESS ARM	1
10	FRONT STABILIZER	1
11	SEAT FRAME	1
12	LEG EXTENSION ARM - bearing pre-installed	1
12R	RIGHT LEG EXTENSION ARM	1
12L	LEFT LEG EXTENSION ARM	1
13	LOW ROW CONNECTOR	1
14	FOOT PLATE	1
15	FOOT PLATE ROLLER	1
16	CHROME SEAT ADJUSTER	1
17	SEAT BACK ADJUSTER	1
18	LAT BAR HOLDER	1
19	METAL HINGE	2
20	CABLE ARM ASSEMBLY	1
20A	CABLE ARM CONNECTOR	1
21	CABLE ARM	2
22	SWIVEL CABLE TOP	2
23	FOAM ROLLER BAR	2
24	PULLEY GUIDE BRACKET	4

25	ADJUSTABLE PULLEY BLOCK	2
27	SINGLE PULLEY BLOCK	1
27A	CABLE GUIDE PLATE	1
28	WEIGHT SHROUD	2
29	LAT BAR	1
30	LOW ROW BAR	1
31	PIVOT AXLE	1
31A	19.92mm AXLE	1
32	CABLE ARM COLLAR	2
33	LEG EXTENSION AXLE	1
34	608ZB BEARING	4
35	STEEL SPACER	2
36	AXLE COLLAR	2
37	BEARING BASIN	4
38	BEARING	4
39	BEARING COVER	4
40	50mm SQ. CAP	4
41	50mm SQ. PLUG	5
41A	40 X 80mm ELLIPTIC PLUG	2
42	37mm OD. BEARING	2
43	30 X 60mm RECT. PLUG	1
44	25 X 50mm RECT. PLUG	1
45	PLASTIC COVER	6
45A	PLASTIC WASHER	6
46	1/2" ROUND PLUG	2
47	PLASTIC GUIDE ROD HOLDER	4
48	1" STEEL BUSHING	2
49	28.6mm STEEL BUSHING	4
50	1/2" X 1-1/8" BEARING	2
51	RED POP PIN	2
52	CLUTCH LEVER OF CABLE ARM	2
53	SPRING KNOB	1
54	MAGNETIC SELECTOR PIN	1

55	L PIN	1
56	3/4" BUSHING	2
57	1" X 200mm HAND GRIP	2
58	1" X 140mm HAND GRIP	2
59	1" X 70mm PRESS ARM STOPPER	2
60	GRIP OF LAT BAR HOLDER (95mm)	2
61	PULLEY	31
62	SMALL PULLEY OF SWIVEL ARM	2
63	RUBBER DONUT	2
64	ADJUSTABLE STOPPER	2
65	1/2" STOPPER	1
66	BACK BRACKET STOPPER	2
67	TOP PLATE	1
68	10 LB. PLATE	19
69	SELECTOR ROD	1
70	NON SLIP	4
71	SNAP HOOK	6
72	LOW ROW CHAIN	1
73	HAND GRIP OF CABLE ARM	2
74	NEW AB CRUNCH	1
75	FOAM PAD	6
75A	COVER OF FOAM PAD	6
76	BACK PAD	1
77	SEAT PAD	1
78	AB CRUNCH CABLE	1
79	CABLE ARM CONNECTING CABLE	1
80	TOP CABLE	1
81	CABLE ARM CABLE	1
82	HEAD OF CABLE ARM CABLE	1
82A	CLUTCH CABLE	2
83	BINDING OF WEIGHT SHROUD	4
84	1/2" X 4" HEX HEAD BOLT	2
85	1/2" X 3" HEX HEAD BOLT	4



85A	1/2" X 1-1/4" HEX HEAD BOLT	2
86	3/8" X 5-3/4" HEX HEAD BOLT	1
87	3/8" X 4-1/2" HEX HEAD BOLT	1
88	3/8" X 3" HEX HEAD BOLT	13
89	3/8" X 2-3/4" HEX HEAD BOLT	4
90	3/8" X 2-1/2" HEX HEAD BOLT	4
91	3/8" X 1-3/4" HEX HEAD BOLT	21
92	3/8" X 1-3/4" HEX HEAD BOLT (ALL)	2
93	3/8" X 1" HEX HEAD BOLT (ALL)	6
94	3/8" X 1/2" ROUND BOLT	4
95	5/16" X 1/2" HEX HEAD BOLT (ALL)	8
96	5/16" X 1-1/2" HEX BOLT	2
97	5/16" X 5/8" INNER HEX SCREW	3
98	3/8" X 5/8" SET SCREW	4
98A	5/16" X 5/8" SCREW	1
99	5/16" X 1/4" SET SCREW	5
100	1/2" WASHER	4
101	3/8" WASHER	60
102	5/16" SMALLER WASHER	10
103	3/8" SPRING WASHER	4
104	5/16" SPRING WASHER	2
105	24mm NYLON NUT	2
106	1/2" NYLON NUT	8
107	3/8" NYLON NUT	47
108	5/16" NYLON NUT	3
109	TOP PLATE BOLT	1
110	3/8" X 3/4" INNER HEX SCREW	2
111	ANKLE STRAP	1
112	3/8" X 1" INNER HEX SCREW	4
114	1" PLUG	2
115	SPRING	1
116	5/16" X 1-1/4" SUNKEN HEAD SCREW	6
117	5/16" NUT	6

118	1-1/4" HAND GRIP	2
119	1" T SHAPE END PLUG	2
120	HOOK PLATE	1
121	COLLAR	2
122	SEALING RING	2
123	M6 SET SCREW	2
124	M5 X 18mm ROUND HEAD SCREW	2
125	M5 NYLON NUT	2
126	CONNECT CABLE	2
127	3/8" X 1-1/4" HEX BOLT	2
128	CAP FOR 3/8" NUT	4
129	5/16" LARGER WASHER	6
130	WEIGHT STACK SPACKER	2

## 7.3 Exploded Drawing: Multi-gym

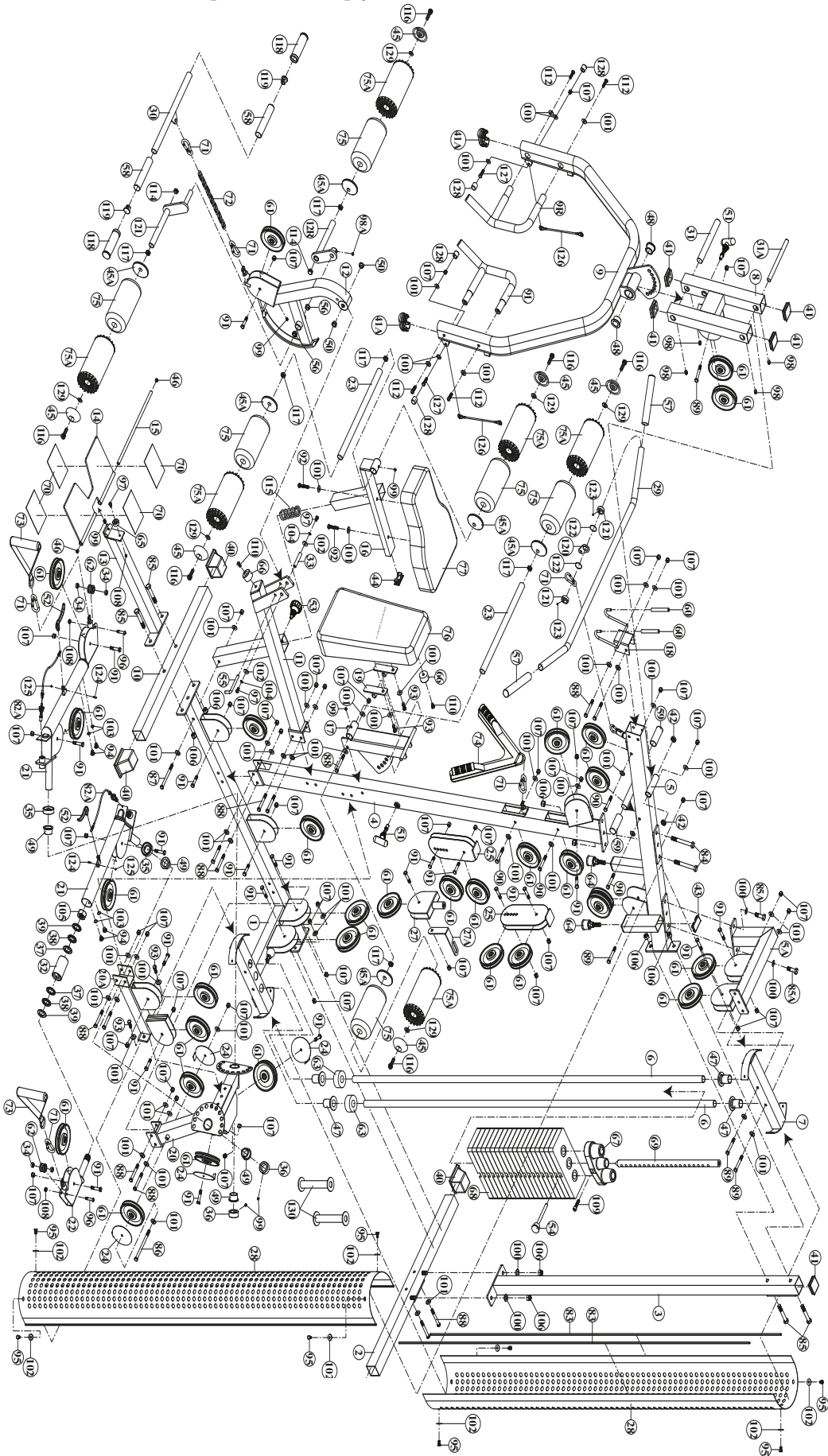

## 7.4 Parts List: Leg Press

No.	Name	Qty.	No.	Name	Qty.
201	BASE STABILIZER	1	222	BEARING	2
202	MAIN FRAME	1	223	LEG PRESS STOPPER	1
203	LEG PRESS SUPPORT	1	224	LEG PRESS BUSHING	2
204	SEAT HANDLE	1	225	3/4" BUSHING	2
205	BACK PAD ADJUSTER	1	226	1-1/4" PLUG	2
206	FOOT PLATE	1	227	1/2" X 4-1/4" HEX BOLT	2
207	CONNECTOR STEEL PLATE	1	228	1/2" X 3/4" HEX THREADED BOLT	4
208	φ 25mm AXLE	1	229	3/8" X 4" HEX BOLT	2
209	φ 3/4" AXLE	1	230	3/8" X 3-1/2" HEX BOLT	1
210	COLLAR	2	231	3/8" X 3" HEX BOLT	5
211	1-1/4" X 360mm HAND GRIP	2	232	3/8" X 1-3/4" HEX BOLT	2
212	NON SLIP	2	233	3/8" X 2-3/4" HEX THREADED BOLT	1
213	BACK PAD	1	234	3/8" X 1" HEX THREADED BOLT	4
214	SEAT PAD	1	235	3/8" X 5/8" SET SCREW	1
215	114mm PULLEY	1	236	1/2" WASHER	8
216	90mm PULLEY	4	237	3/8" WASHER	17
217B	LEG PRESS CABLE	1	238	1/2" NYLON NUT	2
218	LOCKING SPRING KNOB	1	239	3/8" NYLON NUT	9
219	50 X 75mm RECT. PLUG	1	240	CAP FOR NUT	4
220	45mm SQ. PLUG	1			
221	75 X 50mm SQ PLUG	2			

# 7.5 Exploded Drawing: Leg Press

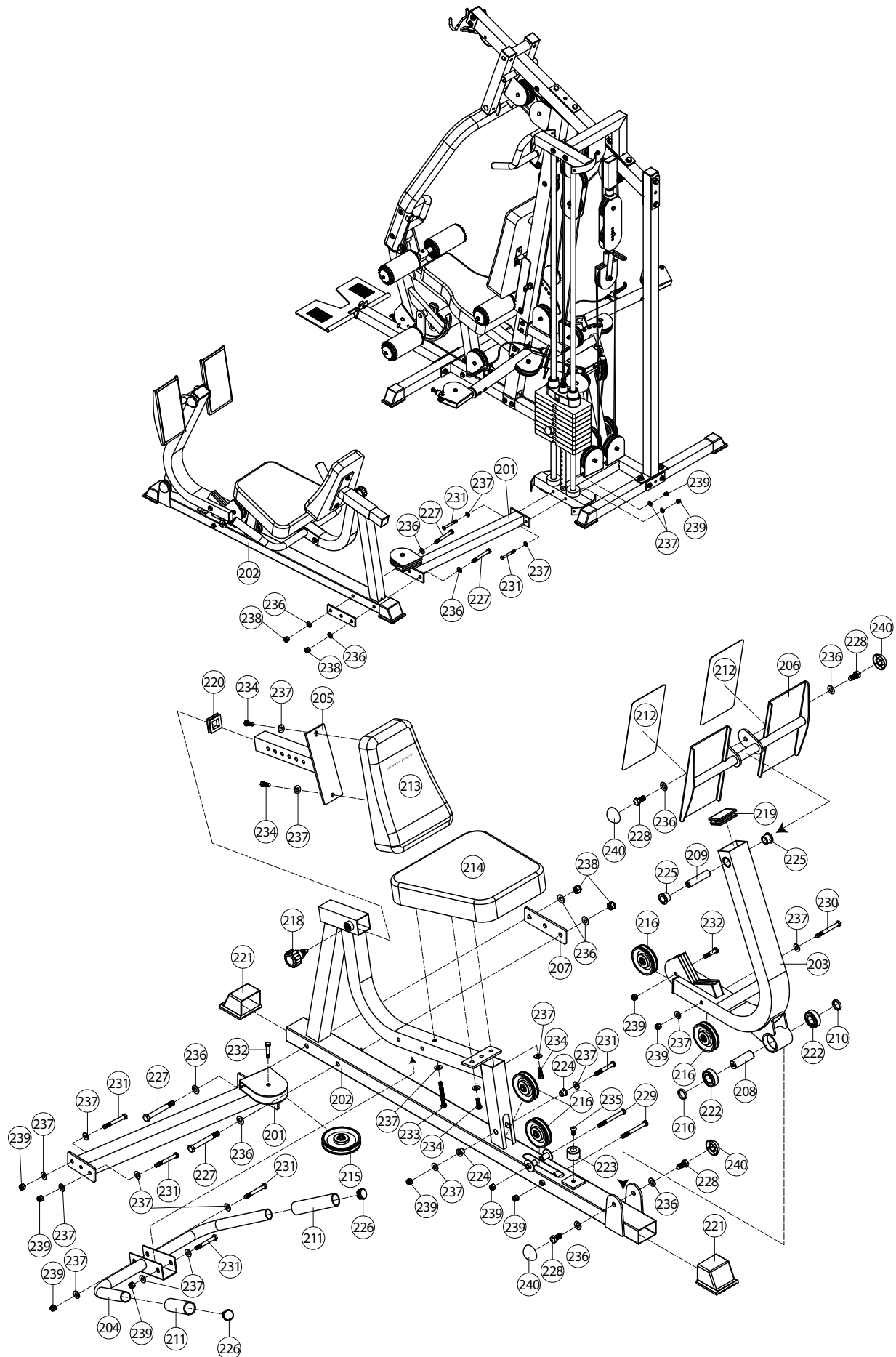

Training equipment from BodyCraft® is subject to strict quality control. However, if a fitness equipment purchased from us does not work perfectly, we take it very seriously and ask you to contact our customer service as indicated. We are happy to help you by phone via our service hotline.

### **Error Descriptions**

Your fitness equipment is developed for long-term, high-quality training. However, should a problem arise, please first read the operating instructions. For further assistance, please contact your contract partner or call our service hotline. To ensure your problem is solved as quickly as possible, please describe the defect as exactly as possible.

In addition to the statutory warranty, we provide a warranty for every fitness equipment purchased from us according to the following provisions.

### **Your statutory rights are not affected.**

### **Warranty**

The warranty is the first/original buyer and/or any person who received a newly purchased product as a gift from the original buyer.

#### **Warranty period**

The warranty periods, shown on our web shop, begin on delivery of the fitness equipment. The respective warranty periods for your equipment can be found on its product website.

### **Repair Costs**

According to our choice, there will either be a repair, a replacement of individual damaged parts or a complete replacement. Spare parts, that have to be mounted while assembling the equipment, have to be replaced by the warranty holder personally and are not a part of repair. After the expiration of the warranty period, the responsibility for parts costs, repair costs, installation costs and delivery costs lies with the warranty holder.

### **The terms of use are defined as follows:**

- + Home use: solely for private use in private households up to 3 hours per day
- + Semi-professional use: up to 6 hours per day (e. g. rehabilitation centres, hotels, clubs, company gyms)
- + Professional use: more than 6 hours per day (e. g. commercial gyms)

### **Warranty Service**

Within the warranty period, equipment which develops faults as a result of material or manufacturing defects, will be repaired or replaced at our discretion. Ownership of equipment or parts of equipment which have been replaced is transferred to us. The warranty period is not extended nor does a new warranty period begin following repair or replacement under the warranty.

## **Warranty Conditions**

For the warranty to be valid, the following steps must be taken:

Please contact our customer service by email or phone. If the product under warranty has to be sent in for repair, the seller bears costs. After expiry of the warranty, the buyer bears the costs of transport and insurance. If the fault is covered by our warranty, you will receive a new or repaired equipment in return.

### **Warranty claims are invalid in case of damage resulting from:**

- + misuse or improper handling
- + environmental influences (moisture, heat, electrical surge, dust, etc.)
- + failure to follow the current safety measures for the equipment
- + failure to follow the operating instructions
- + use of force (e. g. hitting, kicking, falling)
- + interventions which were not carried out by one of our authorized service centres
- + unauthorised repair attempts

### **Proof of Purchase and Serial Number**

Please make sure that you are able to provide the appropriate receipt when claiming on your warranty. So that we can clearly identify the model of your equipment, and for the purposes of our quality control, you will need to give the serial number of your equipment, when contacting the service team. Where possible please have your serial number and your customer number ready when you call our service hotline. It will help us to deal with your request swiftly.







































If you cannot find the serial number on your fitness equipment, our service team is at your disposal to offer further information.

### **Service outside of the Warranty Period**

We are also happy to issue an individual cost estimate if there is a problem with your fitness equipment after the warranty has expired, or in cases which do not fall under the terms of the warranty, e. g. normal wear and tear. Please contact our customer service team to find a quick and cost-effective solution to your problem. In such a case you will be responsible for the delivery costs.

### **Communication**

Many problems can be solved just by speaking to us as your specialist supplier. We know how important it is to you as a user of the fitness equipment to have problems solved quickly and simply, so you can enjoy working out with minimal interruption. For that reason, we also want to resolve your queries quickly and in a straightforward manner. Thus, please always keep your customer number and the serial number of the faulty equipment handy.

DE	DK	FR
<p><b>TECHNIK</b></p> <p> +49 4621 4210-900</p> <p> +49 4621 4210-698</p> <p> technik@sport-tiedje.de</p> <p> Öffnungszeiten entnehmen Sie unserer Homepage.</p> <p><b>SERVICE</b></p> <p> 0800 20 20277 (kostenlos)</p> <p> 04621 4210 - 0</p> <p> info@sport-tiedje.de</p> <p> Öffnungszeiten entnehmen Sie unserer Homepage.</p>	<p><b>TEKNIK OG SERVICE</b></p> <p> 80 90 16 50</p> <p>+49 4621 4210-945</p> <p> info@fitshop.dk</p> <p> Åbningstider kan findes på hjemmesiden.</p>	<p><b>TECHNIQUE &amp; SERVICE</b></p> <p> +33 (0) 189 530984</p> <p>+49 4621 42 10 933</p> <p> info@fitshop.fr</p> <p> Vous trouverez les heures d'ouverture sur notre site Internet.</p>
	PL	BE
	<p><b>DZIAŁ TECHNICZNY I SERWIS</b></p> <p> 22 307 43 21</p> <p>+49 4621 42 10-948</p> <p> info@fitshop.pl</p> <p> Godziny otwarcia można znaleźć na stronie głównej.</p>	<p><b>TECHNIQUE &amp; SERVICE</b></p> <p> 02 732 46 77</p> <p>+49 4621 4210 933</p> <p> info@fitshop.be</p> <p> Vous trouverez les heures d'ouverture sur notre site Internet.</p>
UK	NL	INT
<p><b>CUSTOMER SUPPORT</b></p> <p> 00800 2020 2772</p> <p>+494621 4210 944</p> <p> info@sport-tiedje.co.uk</p> <p> You can find the opening hours on our homepage.</p>	<p><b>TECHNISCHE DIENST &amp; SERVICE</b></p> <p> +31 172 619961</p> <p> info@fitshop.nl</p> <p> De openingstijden vindt u op onze homepage.</p>	<p><b>TECHNICAL SUPPORT &amp; SERVICE</b></p> <p> +49 4621 4210-944</p> <p> service-int@sport-tiedje.de</p> <p> You can find the opening hours on our homepage.</p>
ES	AT	CH
<p><b>TECNOLOGÍA Y SERVICIOS</b></p> <p> 911 238 029</p> <p> info@fitshop.es</p> <p> Consulta nuestro horario de apertura en la página web.</p>	<p><b>TECHNIK &amp; SERVICE</b></p> <p> 0800 20 20277 (Freecall)</p> <p>+49 4621 42 10-0</p> <p> info@sport-tiedje.at</p> <p> Öffnungszeiten entnehmen Sie unserer Homepage.</p>	<p><b>TECHNIK &amp; SERVICE</b></p> <p> 0800 202 027</p> <p>+49 4621 42 10-0</p> <p> info@sport-tiedje.ch</p> <p> Öffnungszeiten entnehmen Sie unserer Homepage.</p>

Please find a detailed overview including address and opening hours for all stores of the Sport-Tiedje Group in Germany and abroad on the following website:

[www.sport-tiedje.com/en/stores](http://www.sport-tiedje.com/en/stores)



# WE LIVE FITNESS

## WEBSHOP AND SOCIAL MEDIA

Sport-Tiedje is Europe's largest specialist store for home fitness equipment with currently over 70 stores and one of the world's most renowned online mail order companies for fitness equipment. Private customers order via the 25 web shops in the respective national language or have their desired equipment assembled on site. In addition, the company supplies fitness studios, hotels, sports clubs, companies and physio practices with professional equipment for endurance and strength training.

Sport-Tiedje offers a wide range of fitness equipment from renowned manufacturers, high-quality in-house developments and comprehensive services, such as a build-up service and sports scientific advice before and after the purchase. The company employs numerous sports scientists, fitness trainers and competitive athletes.

Visit us also on our social media platforms or our blog!

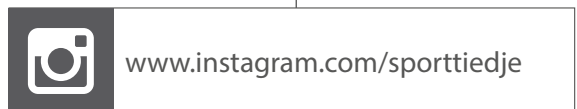
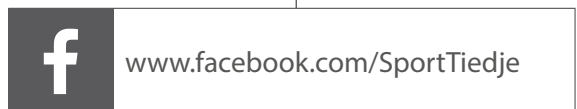

**Notes**

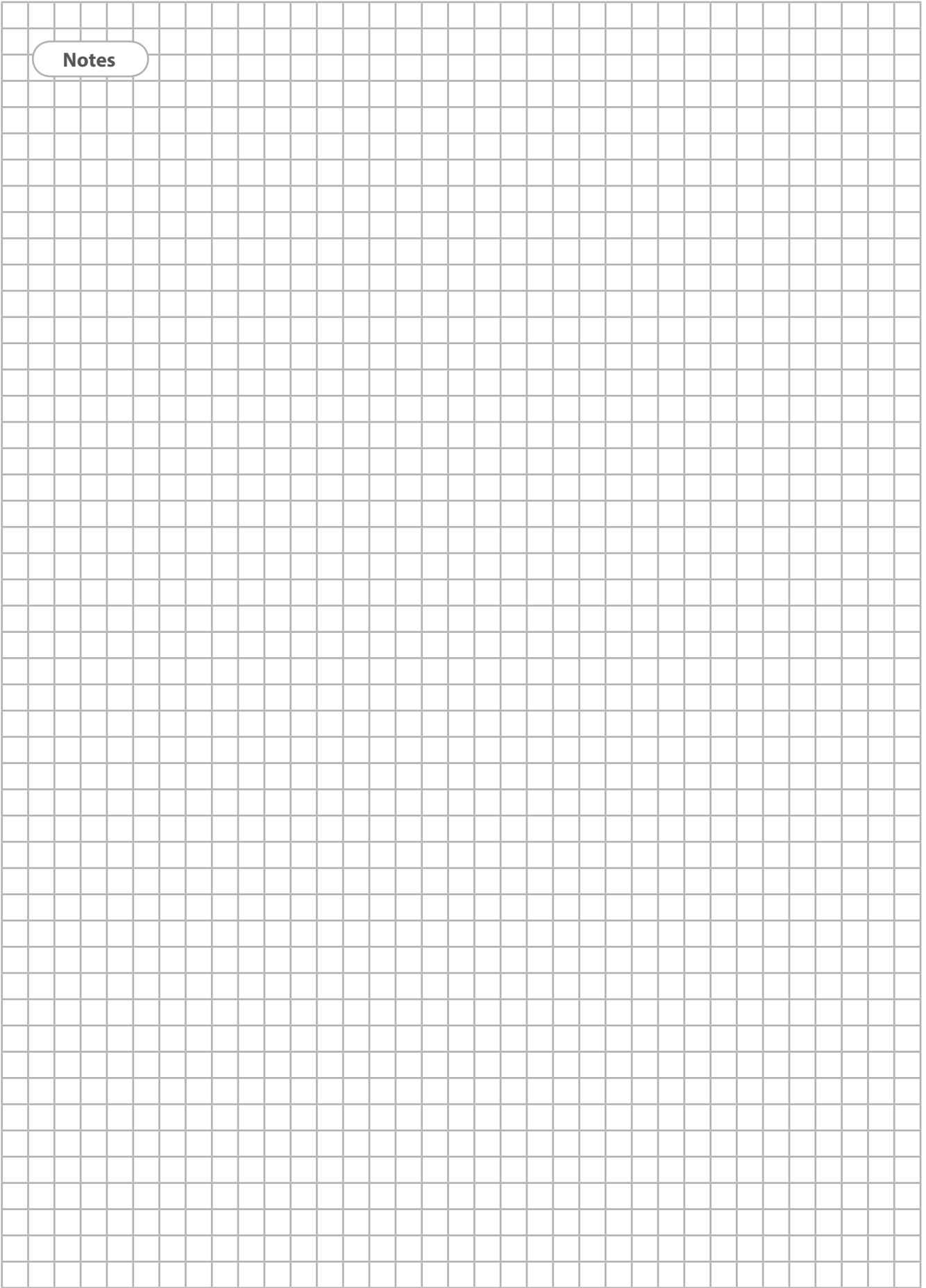



***BODYCRAFT***