

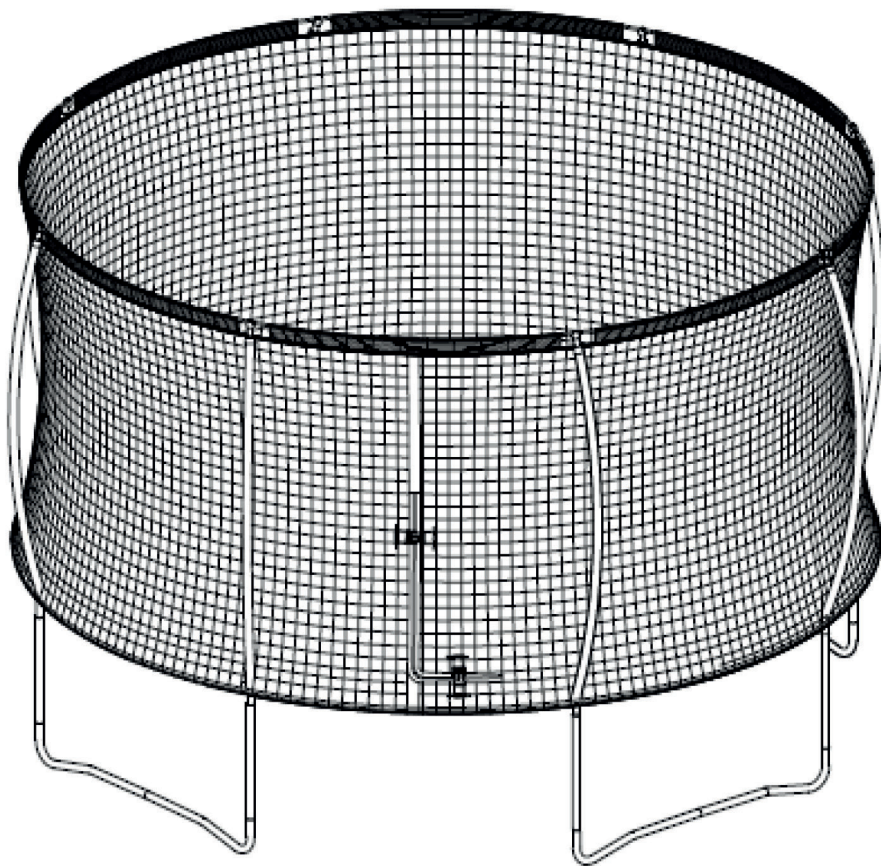

Assembly Instructions



max. 120 kg



~ 120 Min.

CJOT305/365/430A.01.03

Art No. CJ-OT-305/365/430-A

Outdoor Trampoline Advanced

Content

1	GENERAL INFORMATION	6
1.1	Technical Data	6
1.2	Personal Safety	7
1.3	Installation Location	8
2	ASSEMBLY	9
2.1	General Instructions	9
2.2	Assembly of the trampoline	10
2.2.1	Package contents	10
2.2.2	Assembly Instructions	11
2.3	Assembly of the safety net	15
2.3.1	Package contents	15
2.3.2	Assembly Instructions	16
2.4	Assembly of the ladder	20
3	TRANSPORT AND STORAGE	21
3.1	General Instructions	21
4	TROUBLESHOOTING, CARE AND MAINTENANCE	22
4.1	General Instructions	22
4.2	Maintenance and Inspection Calendar	22
5	DISPOSAL	23
6	RECOMMENDED ACCESSORIES	24
7	ORDERING SPARE PARTS	25
7.1	Serial Number and Model Name	25
7.2	Parts List	26
7.3	Exploded Drawing	27
8	WARRANTY	29
9	CONTACT	31

Dear customer,

Thank you for choosing a high-quality equipment of the brand cardiojump®. cardiojump® offers sports and fitness equipment for the sophisticated home sport and the equipment of fitness studios and business customers. With cardiojump® fitness equipment, the focus is on what sport is all about: maximum performance! Therefore, the equipment is developed in close consultation with athletes and sports scientists. Because athletes know best what makes perfect fitness equipment.

Further information can be found at www.sport-tiedje.com.

Intended Use

The equipment may only be used for its intended purpose.

The equipment is only suitable for home use outdoor. The equipment is not suitable for semi-professional (e.g. hospitals, associations, hotels, schools, etc.) and commercial or professional use (e.g. fitness studios).

Legal Notice

Sport-Tiedje GmbH
Europe's No. 1 for home fitness

International Headquarters
Flensburger Straße 55
24837 Schleswig
Germany

Management:
Christian Grau
Sebastian Campmann
Dr. Bernhard Schenkel
No. HRB 1000 SL
Local Court Flensburg
European VAT Number: DE813211547

Disclaimer



©2018 cardiojump® is a registered brand of the company SportTiedje GmbH. All rights reserved. Any use of this trademark without the explicit written permission of Sport-Tiedje is prohibited.

Product and manual are subject to change. Technical data can be changed without advance notice.

ABOUT THIS MANUAL

Please carefully read the entire manual before installation and first use. The manual will help you to quickly set up the system and explains how to safely use it. Make sure that all persons exercising with the equipment (especially children and persons with physical, sensory, mental or motor disabilities) are informed about this manual and its contents in advance. In case of doubt, responsible persons must supervise the use of the equipment.

This product complies with the DIN EN71-14 standards.



This equipment has been manufactured according to the latest safety knowledge. As far as possible, potential safety hazards which could cause injury have been eliminated. Make sure to carefully follow the instructions and that all parts are securely in place. If required, read through the instructions again to correct any mistakes.

Please pay close attention to the safety and maintenance instructions given here. The contract partner cannot be held liable for damage to health, accidents or damage to the equipment when it is not used in accordance with these instructions.

The following safety instructions may appear in this manual:

► **ATTENTION**

This notice indicates potentially hazardous situations which, if not avoided, may result in property damage.

⚠ **CAUTION**

This notice indicates potentially hazardous situations which, if not avoided, may result in slight or minor injuries!

⚠ **WARNING**

This notice indicates potentially hazardous situations which, if not avoided, may result in death or serious injuries!

⚠ **DANGER**

This notice indicates potentially hazardous situations which, if not avoided, will result in death or serious injuries!

ⓘ **NOTICE**

This notice indicates further useful information.

Retain these instructions in a safe place for future reference, maintenance or when ordering replacement parts.

1.1 Technical Data

Weight and dimensions:

Article weight (gross, excl. packaging):

Ø 305cm: 43 kg

Ø 365cm: 60.5 kg

Ø 430cm: 69 kg

Height inclusive safety net:

Ø 305cm | H 253cm

Ø 365cm | H 274cm

Ø 430cm | H 274cm

Maximum user weight: Ø 305 & 365 cm: 100kg / Ø 430cm: 120 kg

1.2 Personal Safety

DANGER

- + The trampoline is not suitable for use by children under the age of 6.
- + Children of 6 years and older can only use the trampoline under adult supervision.
- + Never jump onto the trampoline from other objects, e.g. from a roof.
- + Before you start using the trampoline, you should consult your physician that this type of exercise is suitable for you from a health perspective. Particularly are persons who: have a hereditary disposition to high blood pressure or heart disease, are over the age of 45, smoke, have high cholesterol values and/or are overweight.
- + Do not do any summersaults or flips on the trampoline. An incorrect landing on the head or neck can lead to injuries, e.g. paralysis.
- + If you notice any signs of weakness, nausea, dizziness, pain, shortness of breath, or other abnormal symptoms, stop exercising immediately and consult your doctor.

WARNING

- + The trampoline shouldn't be used by more than one person at the same time - as there is a high danger of colliding with one another, leading to injuries.
- + Children should not be unsupervised when they are around the trampoline.
- + Please familiarise yourself with the trampoline before use. Please seek advice from a specialist on the proper use of this product.
- + The trampoline cannot be used when the jumping mat is wet or dirty.
- + No eating or drinking allowed while using the trampoline.
- + No smoking allowed while using the trampoline.
- + Do not use the trampoline under the influence of drugs and alcohol.
- + Free your hands and pockets from objects before using the trampoline.
- + Always jump in the middle of the trampoline. Jumping purposely against the safety net, frame covers or on the springs can lead to injuries.
- + Safely secure the trampoline from unauthorised use, e.g. from small children!
- + Make sure that the opening of the safety net is closed before each use.
- + Keep your hands, feet and other body parts, hair, clothing, jewellery and other objects well clear of moving parts.
- + Before using the trampoline please take off jewellery and similar items.
- + Before each use of the trampoline please check that nothing is underneath the jumping mat.

 **CAUTION**

- + The equipment may only be used for its intended purpose.
- + Every other usage is prohibited and potentially dangerous. The manufacturer/retailer will not be held responsible for damages resulting from incorrect usage or usage not for its intended purpose.
- + Wear suitable clothing while using the trampoline. We recommend primarily sports clothing and socks. Do not wear shoes while using the trampoline! Inspect your clothing so that no objects, e.g. small hooks, can get tangled with the safety net.
- + Enter and exit the trampoline only by climbing through the opening of the safety net.
- + Do not climb on the safety net or up the safety poles.
- + Learn the basics of jumping on a trampoline before attempting advanced manoeuvres.
- + Inspect the trampoline before each use for signs of wear, defects or missing pieces.
- + Avoid from jumping too high. Always stay in control over your jumps.

 **ATTENTION**

- + Remove all pointed and sharp objects on and around the trampoline before usage.
- + Avoid having open fires near the trampoline, don't place a barbecue in the immediate vicinity of the trampoline.
- + The opening of the trampoline must be kept free of foreign objects.

1.3 Installation Location

 **WARNING**

- + A safety area of at least 7m above the trampoline, measured from the ground), must be clear. Also the trampoline should not be placed in main passageways or escape routes.
- + Choose a location in which there is enough free space/clearance, of at least 2m, to the front, rear and sides of the trampoline.

 **CAUTION**

- + Make sure that the trampoline is flat and even on the ground.

2.1 General Instructions



DANGER

- + Do not leave any tools, packaging materials such as foils or small parts lying around, as otherwise there is a danger of suffocation for children. Keep children away from the equipment during assembly.



WARNING

- + The assembly and usage of the trampoline should not be undertaken during wind, rain and storms, also especially with thunder! We recommend that in these conditions that the trampoline should be secured, e.g. with earth anchors. In extreme weather conditions (severe storm) we recommend further securing the trampoline or, at best, to dismantle the trampoline.
- + Pay attention to the instructions attached to the equipment in order to reduce the risk of injuries.



CAUTION

- + Do not open the packaging when it is lying on its side.
- + Ensure you have sufficient room for movement in each direction during assembly.
- + The assembly of the equipment must be carried out by at least two adults. If in doubt, seek the help of a third technically skilled person.



ATTENTION

- + To prevent damage to the equipment and the floor, assemble the equipment on a mat or on top of the packaging.



NOTICE

- + Some of the pieces used could already be pre-assembled, so that assembly is as simple as possible and to save on packaging materials.
- + Ideally the assembly should take place at the installation location.
- + To guarantee a long lasting safety level, we recommend getting the trampoline regularly serviced (once a year) from specialists (Sport-Tiedje service technicians).

2.2 Assembly of the trampoline

2.2.1 Package contents

The package contents consists of the following illustrated parts. Check that all parts of the package contents have been delivered. Should a part be missing or transport damages are discovered, please immediately contact your contract partner.

NOTICE

For the assembly of the safety net, a spanner and a screwdriver are required. These are not included in the package contents.

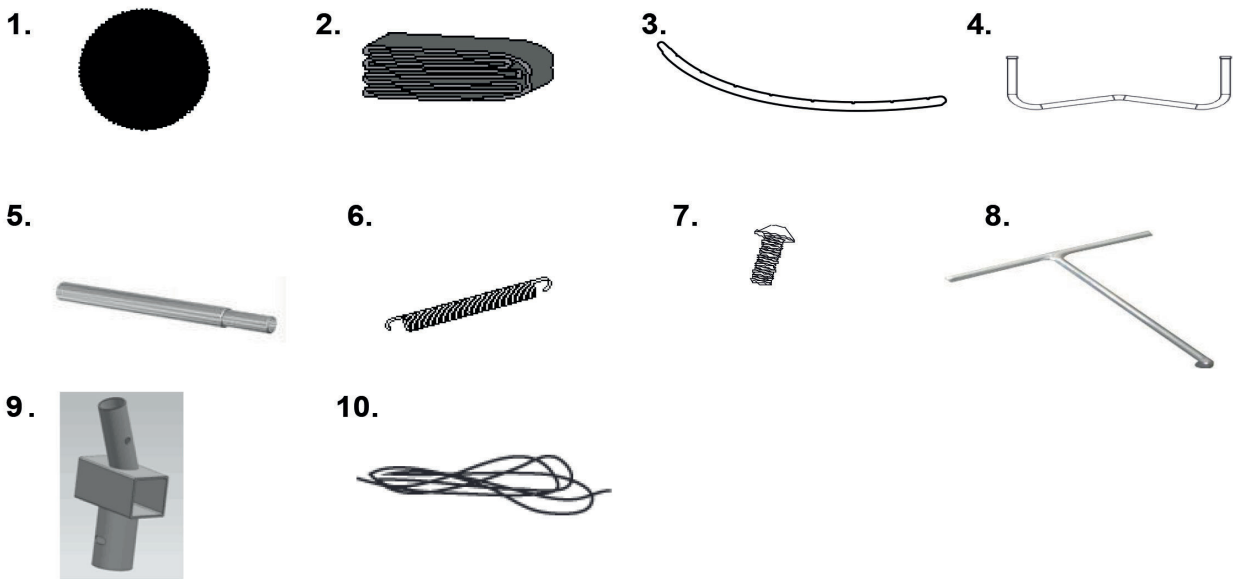

No.	Name	10'	12'	14'
1	Mat	1	1	1
2	Frame Pad	1	1	1
3	Top Frame	6	8	8
4	Leg Base	3	4	4
5	Leg Extension	6	8	8
6	Springs	54	72	88
7	Screw	12	16	16
8	Spring Tool	1	1	1
9	T Connector	12	16	16
10	Rope	2	2	2

2.2.2 Assembly Instructions

Before assembly, take a close look at the individual assembly steps shown and carry out the assembly in the order given.

305 cm (3 legs)

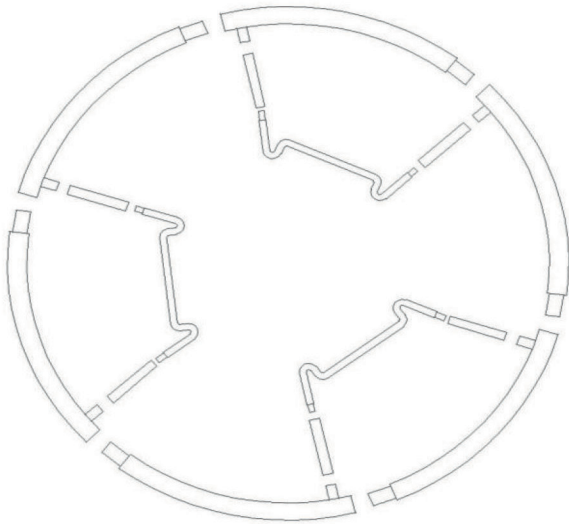

15 parts

365 cm and 430 cm (4 legs)

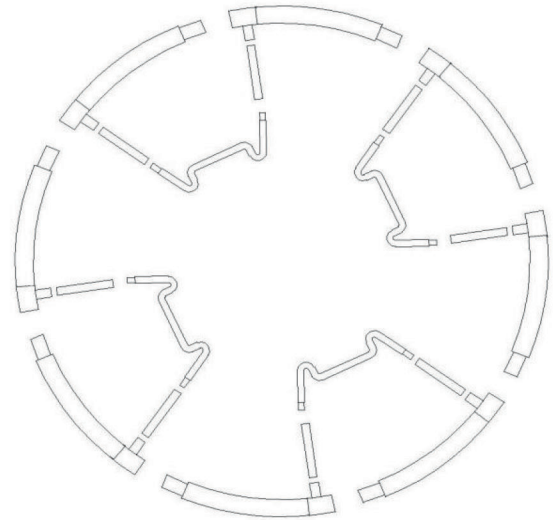

20 parts

- ① **NOTICE**
Please note that the trampoline in size 305cm only has three legs when compared to the other sizes.
- ① **NOTICE**
At least two people are required to assemble this trampoline!

Step 1:

1. Connect two top frames (3) with a T connector (9).
2. Insert one leg extension (5) each into the leg receptacle of the T-connectors (9).
3. Secure the leg extensions (5) with a bolt (7).

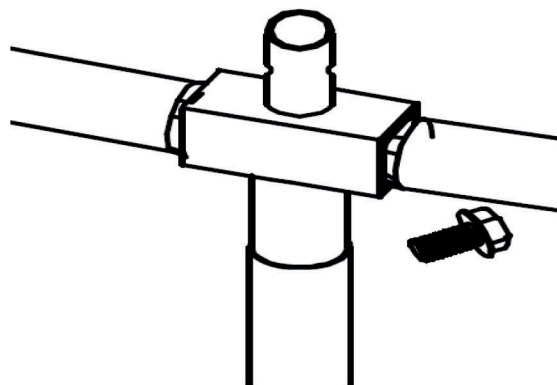

Step 2:

1. Assemble another T-connector (9) and a leg extension (5) at the end of the frame assembly made in step 1.
2. Insert a leg base (4) into the leg extensions (5).
3. Secure the leg base (4) with a bolt (7).
4. Continue these steps until the entire frame of the trampoline is finished.

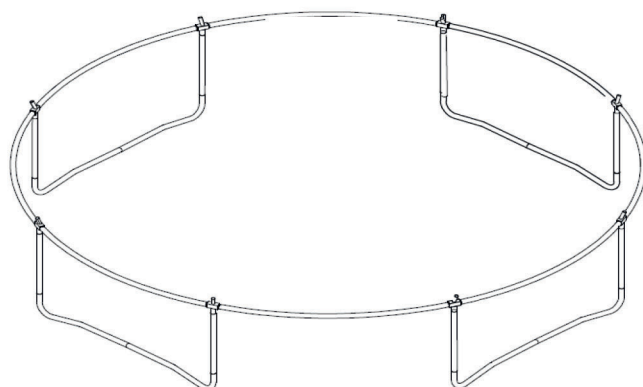
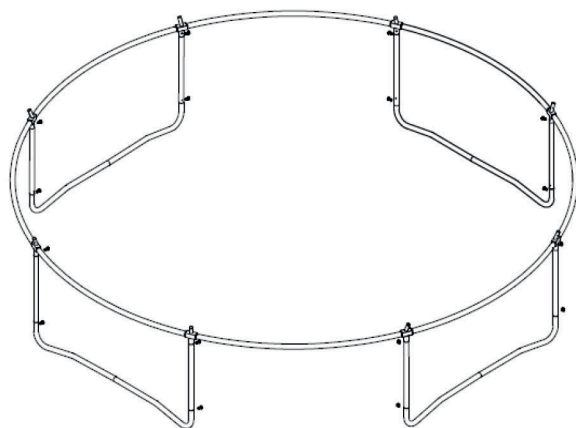

Step 3:

Spread out the mat (1) inside the frame.

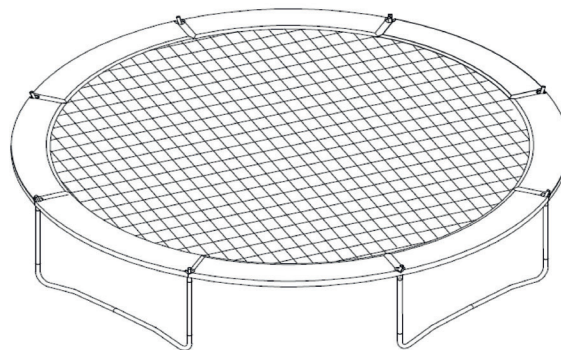

Step 4:



WARNING:

Crushing hazard!

While attaching the springs, please take care NOT to grip the springs with your hand and only to utilise the spring tensioner tool. While releasing the tension it could lead to crushing between the springs.

1. Hang one end of the spring in one of the loops of the jumping mat.
2. Pull with the spring tensioning tool towards the frame.
3. Hook the other end of the spring, with the spring tensioning tool, into the corresponding hole in the frame.
4. With the spring tensioning tool, place the springs in the order shown in the following table and figure. The number corresponds to the respective loop on the jumping mat. The springs are approximately placed in quarters, using the spring tensioning tool, from each other.

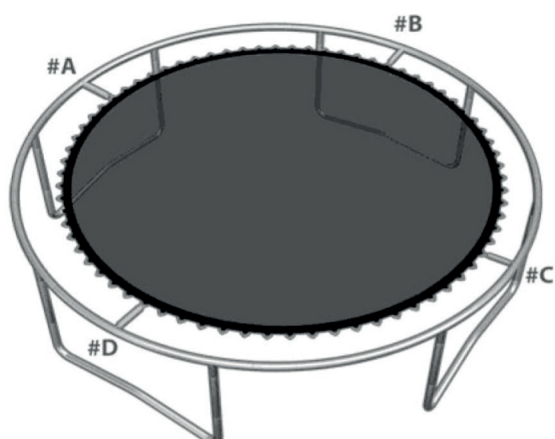
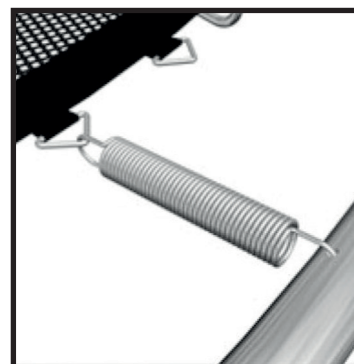
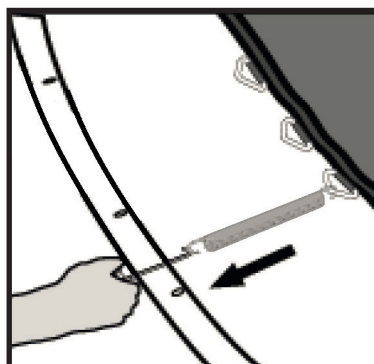

Trampoline	#A	#B	#C	#D
305 cm	1	14	28	42
365 cm	1	18	36	54
430 cm	1	22	44	66

Step 5:

1. Place the frame pad (2) over the trampoline so that the springs and the frame are covered.
2. Tie the cords that are on the bottom of the frame pad (2) on the frame.
3. Attach the frame pad (2) to the mat sheet (1) using the rope (10).

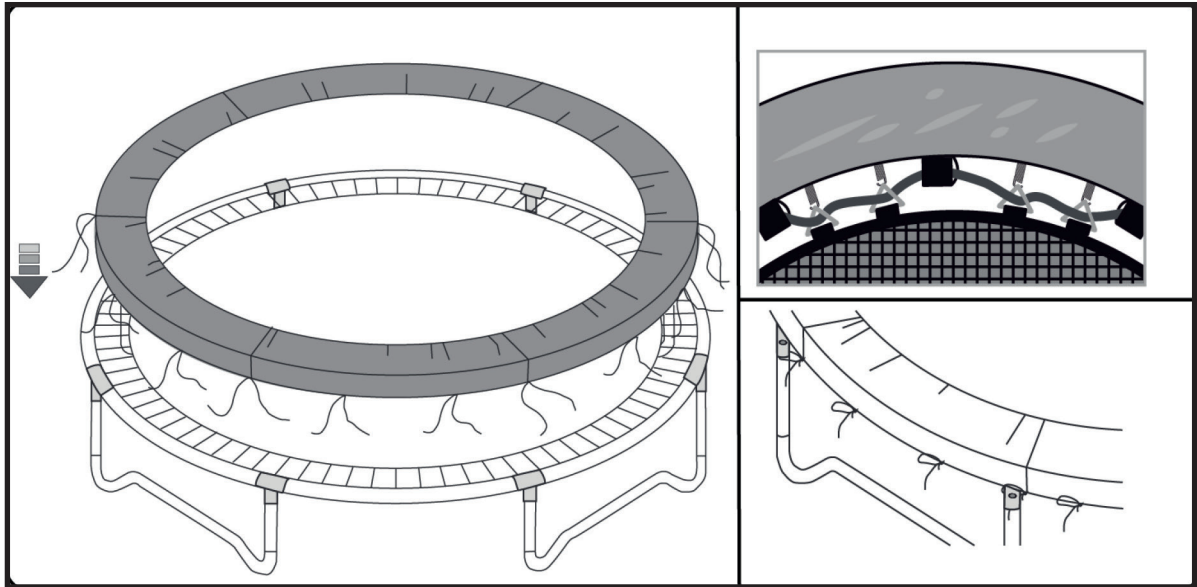

2.3 Assembly of the safety net

2.3.1 Package contents

The package contents consists of the following illustrated parts and tools. Check that all parts of the package contents have been delivered. Should a part be missing or transport damages are discovered, please immediately contact your contract partner.

NOTICE

For the assembly of the safety net, a spanner and a screwdriver are required. These are not included in the package contents.

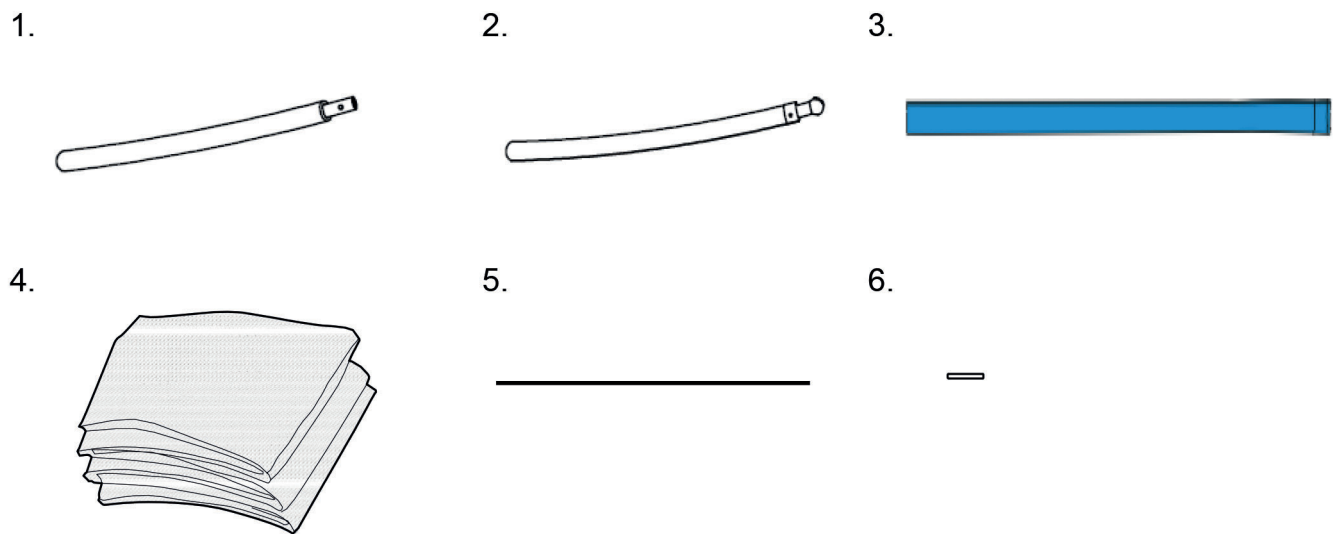

No.	Name	10'	12'	14'
1	Bottom Tube	6	8	8
2	Top Tube	6	8	8
3	Sleeve	6	8	8
4	Net	1	1	1
5	Fiberglass Rod	10	12	14
6	Galv. Connector	10	12	14

2.3.2 Assembly Instructions

Before assembly, take a close look at the individual assembly steps shown and carry out the assembly in the order given.

① NOTICE

The assembly of this safety net should be carried out by at least two adults!

Step 1:

1. Connect the bottom and top poles for the safety net (1 & 2).



2. Slide the poles into the sleeves (3).



3. Clamp each of the poles into the T connectors (9) on the trampoline.

Step 2:

1. Connect the fibreglass rods (5) using the connectors (6).

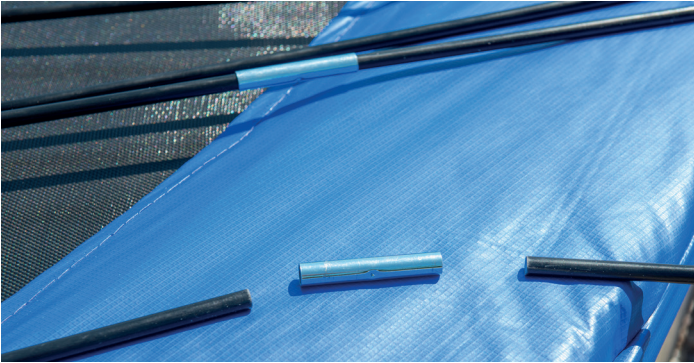

2. Spread the net (4) on the ground.



3. Pass the two lengths of poles (5) through the loops at the top of the net (4).



4. Pass the rods through the loops of the net and join the poles together at one end.



5. To make the last connection, have one person stand on the opposite side.



6. Push the poles towards the centre of the ring until they line up and make the last connection.



Step 3:

1. Put the net in the right position and attach the ring to the upper poles (2).
2. Start at the entrance and connect one hook to each spring.
3. The remaining hooks can now be attached to the ends of the springs.

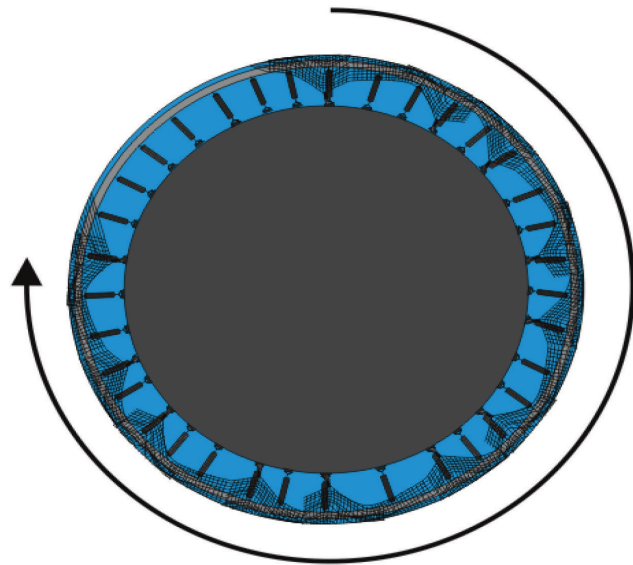
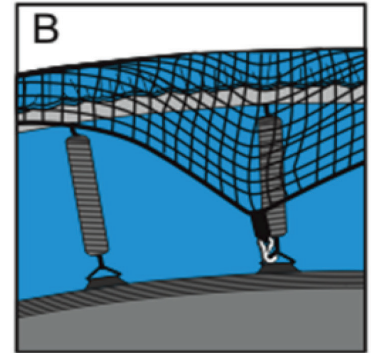
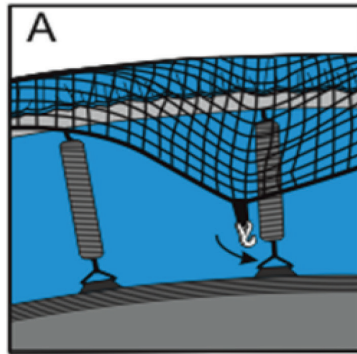
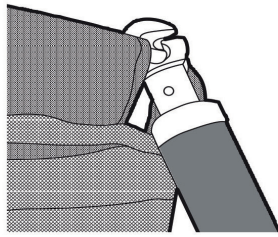

2.4 Assembly of the ladder

① NOTICE

Dependant on the model, the number of rungs and screws can vary.

Step 1:

Place the rung between the two rails as pictured.

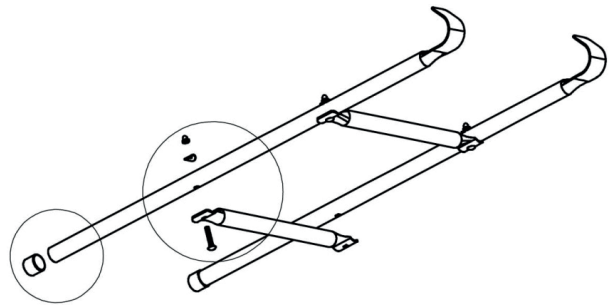

Step 2:

Fasten the rungs, each with two screws, two curved washers and two nuts, onto the rails (see figure).

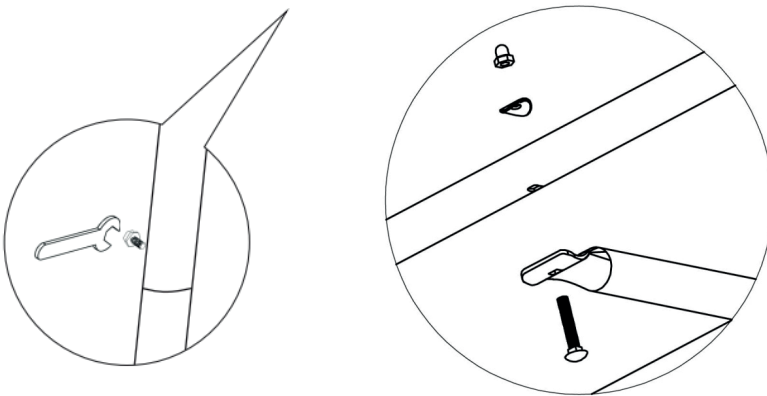

Step 3:

Hang the ladder on the frame of the trampoline.

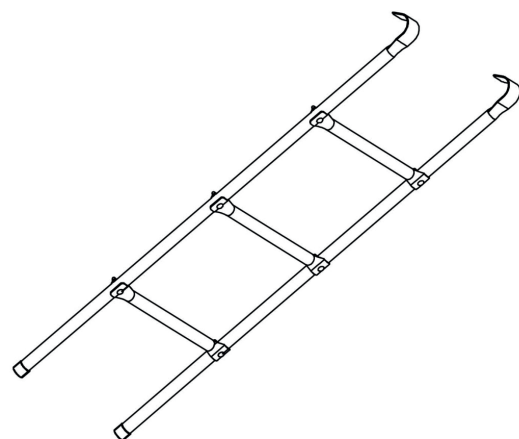

3.1 General Instructions



WARNING

+ The storage location should be chosen so that improper use by third parties or children can be prevented.



CAUTION

+ Should you want to move the trampoline, lift the trampoline with at least one other adult. Lift at the connection points and carry it to the desired location. Slowly place the trampoline back onto the ground. The new location should take into account the recommendations stated in section 1.3. in this manual. For longer distances, the trampoline should be disassembled for transport.



ATTENTION

+ Make sure that the trampoline is protected from moisture, dust and dirt in the selected storage location. The storage location should be dry and well ventilated and have a constant ambient temperature between 5°C and 45°C.

4.1 General Instructions



WARNING

+ Do not make any improper changes to the trampoline and its accessories.



CAUTION

+ Damaged or worn components may affect your safety and the life of the trampoline. Therefore, immediately replace damaged or worn components. In such a case, contact your contract partner. The trampoline can not be used until it has been repaired. When possible, use only original spare parts.

► ATTENTION

+ In addition to the instructions and recommendations for maintenance and care given here, additional service and/or repair work may be necessary; this must only be carried out by authorised service technicians.

4.2 Maintenance and Inspection Calendar

To avoid damage from body sweat, the trampoline must be cleaned with a damp towel (no solvents!) after each training session.

The following routine tasks must be performed at the specified intervals:

Part	Weekly	Monthly	Quarterly	Half-yearly	Yearly
Jumping mat and springs		I/C			
Frame		I/C			
Frame padding		I/C			
Screw connections		I			
Insert connections		I			
Legend: I = Inspect, C = Clean					

5 DISPOSAL

At the end of its operational life, this equipment cannot be disposed of in normal household waste. Instead, it must be disposed of via an electricals recycling centre. Further information can be obtained from your local authority's recycling service.



The materials can be recycled as per their symbols. Through the reuse, recycling of materials or other forms of recovery of old equipment, you make an important contribution to the protection of the environment.

6 RECOMMENDED ACCESSORIES

To make your training experience even more efficient and pleasant, we recommend that you add suiting accessories to your fitness equipment. This could be a **floor mat**, for example, which makes your fitness equipment stand more securely and also protects the floor from falling sweat, but it could also be additional handrails on some treadmills or **silicone spray** to keep moving parts in good shape.

If you have purchased a fitness machine with pulse training and want to train your heart rate, we strongly recommend that you use a compatible chest strap, as this ensures optimum transmission of the heart rate. You may want to buy additional **grips** or **weights** for multi gyms.

Our range of accessories offers the highest quality and makes training even better. If you would like to find out more about compatible accessories, please go to the detail page of the product in our webshop (the easiest way is to enter the article number in the search field above) and go to the recommended accessories on this page. Of course, you can also contact our customer service: by telephone, e-mail, in one of our branches or via our social media channels. We will be happy to advise you!



floor mat



chest strap



chest strap contact gel



silicone spray



towels

7.1 Serial Number and Model Name

In order to provide you with the best possible service, please have the model name, article number, serial number, exploded drawing and parts list ready. The corresponding contact options can be found in chapter 9 of this operating manual.

NOTICE

The serial number of your equipment is unique. It's located on a white sticker.

Enter the serial number in the appropriate field.

Serial number:

Brand / Category:

Model Name:

Article Number:

7.2 Parts List

Trampoline

No.	Name	Qty.	10'	12'	14'	
1	TR800	Trampoline Mat, stitched with V-Rings	Pcs	1	1	1
2	TR801	Frame Pad	Pcs	1	1	1
3	TR802	Top Frame	Pcs	6	8	8
4	TR803	Leg Base	Pcs	3	4	4
5	TR804	Leg Extension	Pcs	6	8	8
6	TR805	Springs	Pcs	54	72	88
7	TR806	Screw	Pcs	12	16	16
7	TR807	spring tool	Pcs	1	1	1
8	TR808	T connector	Pcs	6	8	8
9	TR809	Ropes	Pcs	2	2	2

Safety Net

No.	Name	Qty.	10'	12'	14'	
1	TR810	Bottom tube	Pcs	6	8	8
2	TR811	Top tube	Pcs	6	8	8
3	TR812	Sleeve	Pcs	6	8	8
4	TR813	Net	Pcs	1	1	1
5	TR814	Fiberglass Rod	Pcs	10	12	14
6	TR815	Galv. Connector	Pcs	10	12	14

Ladder

No.	Name	Qty.	10'	12' + 14'	
1	LD001	Frame poles	Pcs	2	
2	LD002	Step poles	Pcs	2	3
3	LD003	Screws	Pcs	4	6
4	LD004	manual	Pcs	1	

7.3 Exploded Drawing

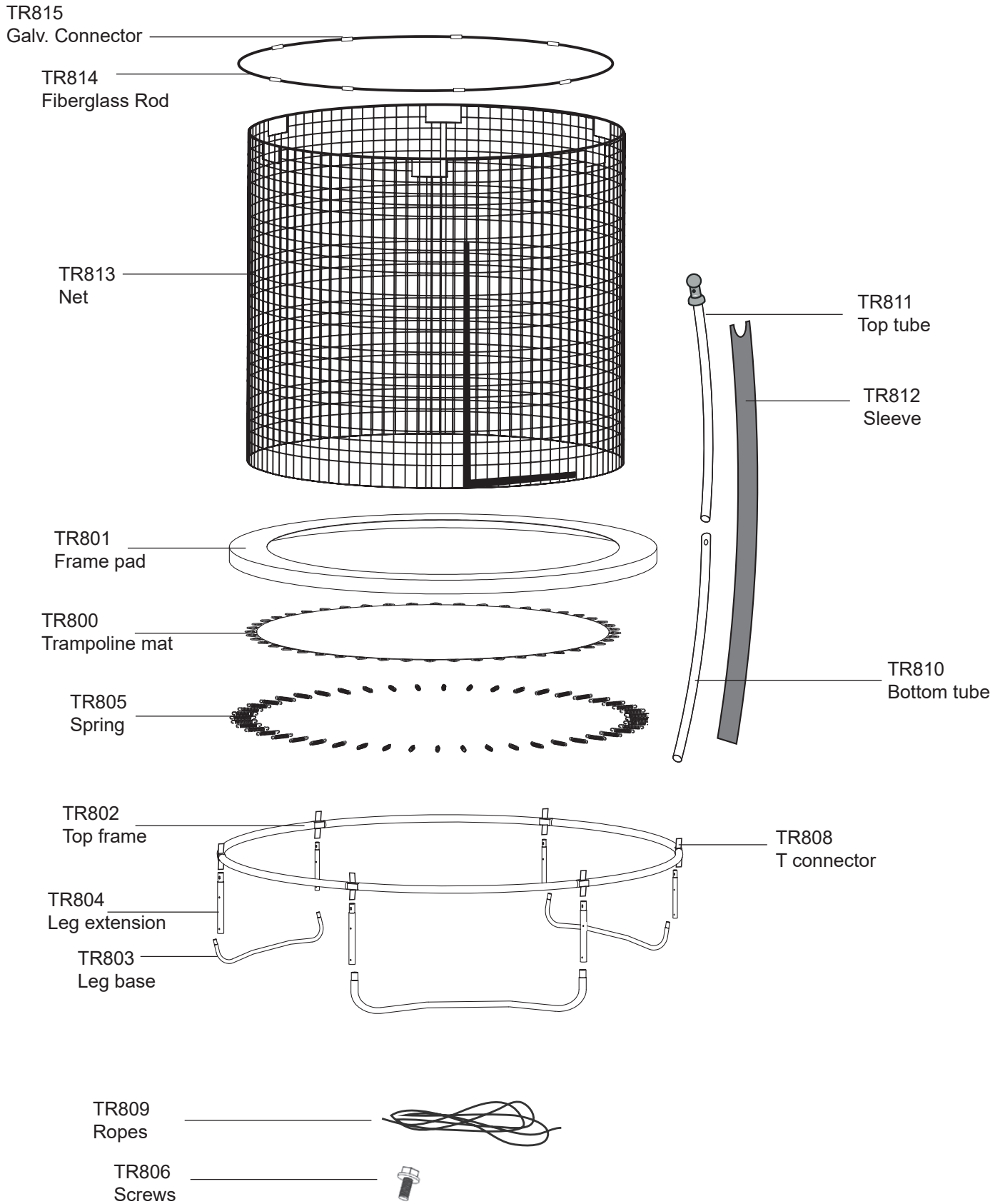

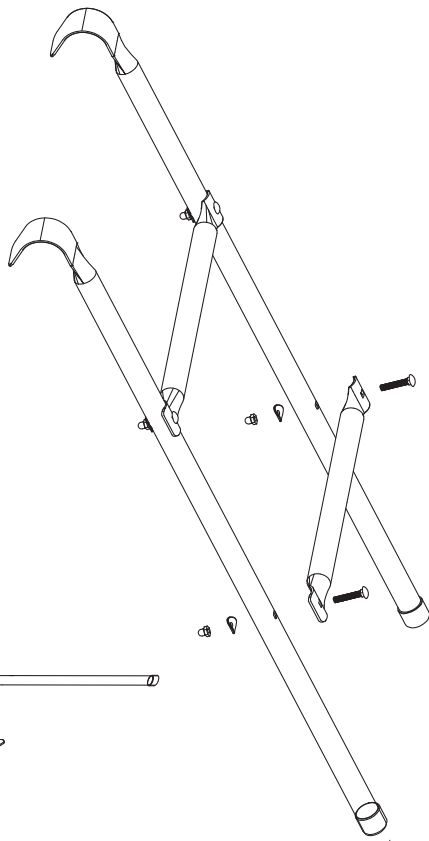

1. LD001 X 2PCS

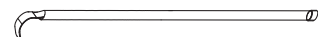

2. LD002 X 2PCS



3. LD003 X 4PCS



4. LD004 X 4PCS



5. LD005 X 4PCS

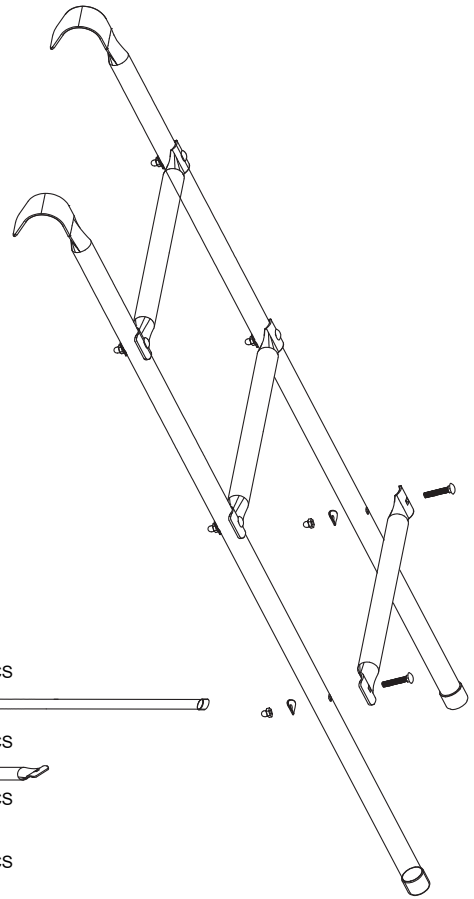

1. LD001 X 2PCS



2. LD002 X 3PCS

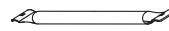

3. LD003 X 6PCS



4. LD004 X 6PCS



5. LD005 X 6PCS



Training equipment from Taurus® is subject to strict quality control. However, if a fitness equipment purchased from us does not work perfectly, we take it very seriously and ask you to contact our customer service as indicated. We are happy to help you by phone via our service hotline.

Error Descriptions

Your fitness equipment is developed for long-term, high-quality training. However, should a problem arise, please first read the operating instructions. For further assistance, please contact your contract partner or call our service hotline. To ensure your problem is solved as quickly as possible, please describe the defect as exactly as possible.

In addition to the statutory warranty, we provide a warranty for every fitness equipment purchased from us according to the following provisions.

Your statutory rights are not affected.

Warrantee

The warrantee is the first/original buyer and/or any person who received a newly purchased product as a gift from the original buyer.

Warranty period

The warranty periods, shown on our web shop, begin on delivery of the fitness equipment. The respective warranty periods for your equipment can be found on its product website.

Repair Costs

According to our choice, there will either be a repair, a replacement of individual damaged parts or a complete replacement. Spare parts, that have to be mounted while assembling the equipment, have to be replaced by the warrantee personally and are not a part of repair. After the expiration of the warranty period for repair costs, a pure parts warranty applies, which does not include the repair, installation and delivery costs.

The terms of use are defined as follows:

- + Home use: solely for private use in private households up to 3 hours per day
- + Semi-professional use: up to 6 hours per day (e. g. rehabilitation centres, hotels, clubs, company gyms)
- + Professional use: more than 6 hours per day (e. g. commercial gyms)

Warranty Service

Within the warranty period, equipment which develops faults as a result of material or manufacturing defects, will be repaired or replaced at our discretion. Ownership of equipment or parts of equipment which have been replaced is transferred to us. The warranty period is not extended nor does a new warranty period begin following repair or replacement under the warranty.

Warranty Conditions

For the warranty to be valid, the following steps must be taken:

Please contact our customer service by email or phone. If the product under warranty has to be sent in for repair, the seller bears costs. After expiry of the warranty, the buyer bears the costs of transport and insurance. If the fault is covered by our warranty, you will receive a new or repaired equipment in return.

Warranty claims are invalid in case of damage resulting from:

- + misuse or improper handling
- + environmental influences (moisture, heat, electrical surge, dust, etc.)
- + failure to follow the current safety measures for the equipment
- + failure to follow the operating instructions
- + use of force (e. g. hitting, kicking, falling)
- + interventions which were not carried out by one of our authorized service centres
- + unauthorised repair attempts

Proof of Purchase and Serial Number

Please make sure that you are able to provide the appropriate receipt when claiming on your warranty. So that we can clearly identify the model of your equipment, and for the purposes of our quality control, you will need to give the serial number of your equipment, when contacting the service team. Where possible please have your serial number and your customer number ready when you call our service hotline. It will help us to deal with your request swiftly.







































If you cannot find the serial number on your fitness equipment, our service team is at your disposal to offer further information.

Service outside of the Warranty Period

We are also happy to issue an individual cost estimate if there is a problem with your fitness equipment after the warranty has expired, or in cases which do not fall under the terms of the warranty, e. g. normal wear and tear. Please contact our customer service team to find a quick and cost-effective solution to your problem. In such a case you will be responsible for the delivery costs.

Communication

Many problems can be solved just by speaking to us as your specialist supplier. We know how important it is to you as a user of the fitness equipment to have problems solved quickly and simply, so you can enjoy working out with minimal interruption. For that reason, we also want to resolve your queries quickly and in a straightforward manner. Thus, please always keep your customer number and the serial number of the faulty equipment handy.

DE	DK	FR
<p>TECHNIK</p> <p> +49 4621 4210-900</p> <p> +49 4621 4210-698</p> <p> technik@sport-tiedje.de</p> <p> Öffnungszeiten entnehmen Sie unserer Homepage.</p> <p>SERVICE</p> <p> 0800 20 20277 (kostenlos)</p> <p> 04621 4210 - 0</p> <p> info@sport-tiedje.de</p> <p> Öffnungszeiten entnehmen Sie unserer Homepage.</p>	<p>TEKNIK OG SERVICE</p> <p> 80 90 16 50</p> <p>+49 4621 4210-945</p> <p> info@fitshop.dk</p> <p> Åbningstider kan findes på hjemmesiden.</p>	<p>TECHNIQUE & SERVICE</p> <p> +33 (0) 189 530984</p> <p>+49 4621 42 10 933</p> <p> info@fitshop.fr</p> <p> Vous trouverez les heures d'ouverture sur notre site Internet.</p>
	PL	BE
	<p>DZIAŁ TECHNICZNY I SERWIS</p> <p> 22 307 43 21</p> <p>+49 4621 42 10-948</p> <p> info@fitshop.pl</p> <p> Godziny otwarcia można znaleźć na stronie głównej.</p>	<p>TECHNIQUE & SERVICE</p> <p> 02 732 46 77</p> <p>+49 4621 4210 933</p> <p> info@fitshop.be</p> <p> Vous trouverez les heures d'ouverture sur notre site Internet.</p>
UK	NL	INT
<p>CUSTOMER SUPPORT</p> <p> 00800 2020 2772</p> <p>+494621 4210 944</p> <p> info@sport-tiedje.co.uk</p> <p> You can find the opening hours on our homepage.</p>	<p>TECHNISCHE DIENST & SERVICE</p> <p> +31 172 619961</p> <p> service@fitshop.nl</p> <p> De openingstijden vindt u op onze homepage.</p>	<p>TECHNICAL SUPPORT & SERVICE</p> <p> +49 4621 4210-944</p> <p> service-int@sport-tiedje.de</p> <p> You can find the opening hours on our homepage.</p>
ES	AT	CH
<p>TECNOLOGÍA Y SERVICIOS</p> <p> 911 238 029</p> <p> info@fitshop.es</p> <p> Consulta nuestro horario de apertura en la página web.</p>	<p>TECHNIK & SERVICE</p> <p> 0800 20 20277 (Freecall)</p> <p>+49 4621 42 10-0</p> <p> info@sport-tiedje.at</p> <p> Öffnungszeiten entnehmen Sie unserer Homepage.</p>	<p>TECHNIK & SERVICE</p> <p> 0800 202 027</p> <p>+49 4621 42 10-0</p> <p> info@fitshop.ch</p> <p> Öffnungszeiten entnehmen Sie unserer Homepage.</p>

Please find a detailed overview including address and opening hours for all stores of the Sport-Tiedje Group in Germany and abroad on the following website:

www.sport-tiedje.com/en/stores

WE LIVE FITNESS

WEBSHOP AND SOCIAL MEDIA

Sport-Tiedje is Europe's largest specialist store for home fitness equipment with currently 80 stores and one of the world's most renowned online mail order companies for fitness equipment. Private customers order via the 25 web shops in the respective national language or have their desired equipment assembled on site. In addition, the company supplies fitness studios, hotels, sports clubs, companies and physio practices with professional equipment for endurance and strength training.

Sport-Tiedje offers a wide range of fitness equipment from renowned manufacturers, high-quality in-house developments and comprehensive services, such as a build-up service and sports scientific advice before and after the purchase. The company employs numerous sports scientists, fitness trainers and competitive athletes.

Visit us also on our social media platforms or our blog!

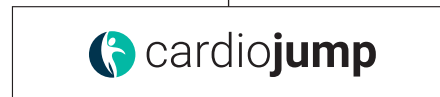
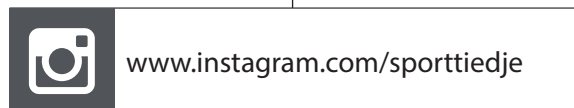
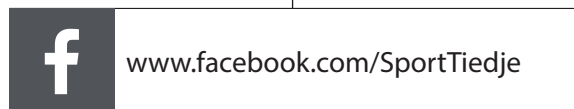

Notes

Notes

