

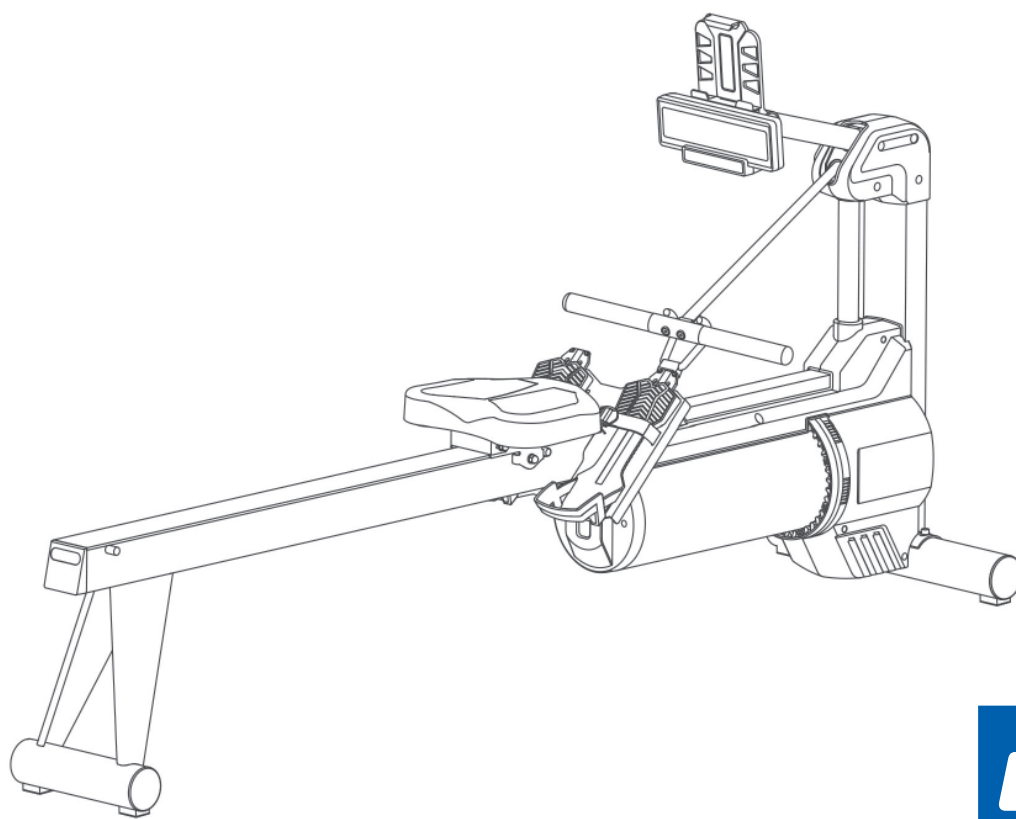

Assembly and Operating Instructions



max. 150 kg



~ 60 Min. 



 35 kg

L 206 | W 55 | H 83-128

CSTAS.01.08

Art. No. CST-AS

Aquastream

Content

1	GENERAL INFORMATION	7
1.1	Technical Data	7
1.2	Personal Safety	8
1.3	Electrical Safety	9
1.4	Set-Up Place	10
2	ASSEMBLY	11
2.1	General Instructions	11
2.2	Scope of Delivery	12
2.3	Assembly	13
3	OPERATING INSTRUCTIONS	24
3.1	Console Display	24
3.2	Button Functions	25
3.3	Functions	26
3.4	Programs	26
3.4.1	TIME PROGRAM	26
3.4.2	METERS PROGRAM	27
3.4.3	CALORIES PROGRAM	28
3.4.4	STROKES PROGRAM	29
3.4.5	INTERVAL 20/10 PROGRAM	30
3.4.6	INTERVAL 20/30 PROGRAM	31
3.4.7	INTERVAL CUST PROGRAM	32
3.4.8	SPM PROGRAM	33
3.4.9	Race Program	34
3.4.10	Heart Rate Controlled Program	35
3.4.11	Recovery Program	36
3.5	5.3 KHZ Chest Belt /Bluetooth Chest Belt	36
3.6	Bluetooth and fitness apps	37
3.7	Notes on correct rowing	38
4	STORAGE AND TRANSPORT	40
4.1	General Instructions	40
4.2	Transportation Wheels	40
5	TROUBLESHOOTING, CARE AND MAINTENANCE	41
5.1	General Instructions	41
5.2	Faults and Fault Diagnosis	41

5.3	Error Codes and Troubleshooting	42
5.4	Maintenance and Inspection Calendar	42
6	DISPOSAL	42
7	RECOMMENDED ACCESSORIES	43
8	ORDERING SPARE PARTS	44
8.1	Serial Number and Model Name	44
8.2	Parts List	45
8.3	Exploded Drawing	50
9	WARRANTY	51
10	CONTACT	53

Dear customer,

thank you for choosing fitness equipment from cardiostrong®. Cardiostrong offers high-quality home fitness equipment that is optimally adapted to the conditions at home. Train at home no matter what the weather or time of the day. cardiostrong fitness equipment offers training programmes and a variety of equipment for all training levels and all training goals. Further information can be found at www.sport-tiedje.com or www.cardiostrong.de. We hope you enjoy your training!

Intended Use

The equipment may only be used for its intended purpose.

This fitness equipment is suitable for home use, semi-professional use and commercial or professional use. The semi-professional sector includes, for example, institutional facilities such as hospitals, schools, hotels and associations. Professional use refers to commercial use, e.g. in a fitness studio.

Disclaimer

©2010 cardiostrong® is a registered brand of the company SportTiedje GmbH. All rights reserved. Any use of this trademark without the explicit written permission of Sport-Tiedje is prohibited.

Product and manual are subject to change. Technical data can be changed without advance notice.

ABOUT THIS MANUAL

Please carefully read the entire manual before installation and first use. The manual will help you to quickly set up the system and explains how to safely use it. Make sure that all persons exercising with the equipment (especially children and persons with physical, sensory, mental or motor disabilities) are informed about this manual and its contents in advance. In case of doubt, responsible persons must supervise the use of the equipment.

Due to ongoing changes and software optimisations, the manual may have to be updated. If you notice any discrepancies during assembly or use, please refer to the manual uploaded to the webshop. The latest manual is always available there.

This equipment has been manufactured according to the latest safety knowledge. As far as possible, potential safety hazards which could cause injury have been eliminated. Make sure to carefully follow the instructions and that all parts are securely in place. If required, read through the instructions again to correct any mistakes.



Please pay close attention to the safety and maintenance instructions given here. The contract partner cannot be held liable for damage to health, accidents or damage to the equipment when it is not used in accordance with these instructions.

The following safety instructions may appear in this manual:

► **ATTENTION**

This notice indicates potentially hazardous situations which, if not avoided, may result in property damage.

⚠ **CAUTION**

This notice indicates potentially hazardous situations which, if not avoided, may result in slight or minor injuries!

⚠ **WARNING**

This notice indicates potentially hazardous situations which, if not avoided, may result in death or serious injuries!

⚠ **DANGER**

This notice indicates potentially hazardous situations which, if not avoided, will result in death or serious injuries!

ⓘ **NOTICE**

This notice indicates further useful information.

Retain these instructions in a safe place for future reference, maintenance or when ordering replacement parts.

1.1 Technical Data

LCD - Display of:

- + Strokes, Strokes per minute
- + Training time in minutes
- + Distance in metres
- + Time/500m: average/current
- + Calorie consumption in kcal
- + Heart rate (when using a chest strap)
- + Watt

Resistance system:	Water resistance
Power supply:	DC Adaptor
Resistance levels:	Micro-Adjustment
Capacity of water tank:	9.7 L
Training programmes in total:	10
Heart rate controlled programs:	1
Watt-controlled programs:	1
Pre-set programs:	10

Weight and dimensions:

Article weight (gross, incl. packaging):	43.1 kg
Article weight (net, without packaging):	34.7 kg
Packaging dimensions (L x W x H):	approx. 124 cm x 90 cm x 37.7 cm
Set-up dimensions (L x W x H):	approx. 206 cm x 54.5 cm x 82.5-128 cm
Folded dimensions (L x W x H):	approx. 84 cm x 54.5 cm x 205.5 cm
Footprint (LxW):	approx. 206 cm x 54.5 cm
Dimensions of rail (L):	approx. 124.5 cm
Maximum user weight:	150 kg

1.2 Personal Safety

DANGER

- + Before you start using the equipment, you should consult your physician that this type of exercise is suitable for you from a health perspective. Particularly affected are persons who: have a hereditary disposition to high blood pressure or heart disease, are over the age of 45, smoke, have high cholesterol values, are overweight and/or have not exercised regularly in the past year. If you are under medical treatment that affects your heart rate, medical advice is absolutely essential.
- + Note that excessive training can seriously endanger your health. Please also note that heart rate monitoring systems can be inaccurate. If you notice any signs of weakness, nausea, dizziness, pain, shortness of breath, or other abnormal symptoms, stop exercising immediately and seek advice from your doctor if necessary.

WARNING

- + This equipment may not be used by children under the age of 14.
- + Children should not be allowed unsupervised access to the equipment.
- + Persons with disabilities must have a medical license and must be under strict observation when using the equipment.
- + The equipment is strictly for use by one person at a time.
- + If your equipment provides a safety key, the clip of the safety key must be attached to your clothing before starting your training. In the event of a fall, the EMERGENCY STOP of the equipment can be initiated.
- + Keep your hands, feet and other body parts, hair, clothing, jewellery and other objects well clear of moving parts.
- + During use, wear suitable sports clothing rather than loose or baggy clothing. When wearing sports shoes, make sure they have suitable soles, preferably made of rubber or other non-slip materials. Shoes with heels, leather soles, studs or spikes are unsuitable. Never exercise barefoot.

CAUTION

- + If your equipment needs to be connected to the power supply with a mains cable, make sure that the cable is not a potential tripping hazard.
- + Make sure that nobody is within the range of motion of the equipment during training so as not to endanger you or other persons.

ATTENTION

- + Do not insert any objects of any kind into the openings of the device.

1.3 Electrical Safety

DANGER

- + In order to reduce the risk of an electric shock, always unplug the equipment from the mains socket immediately after your workout, before assembly or dismantling, and before maintenance or cleaning. Do not pull on the cable.

WARNING

- + Do not leave the equipment unattended while the mains cable is plugged into the mains socket. During your absence, the mains cable must be removed from the mains socket to prevent improper use by third parties or children.
- + If the mains cable or plug is damaged or defective, contact your contract partner. Until repair, the equipment must not be used.

ATTENTION

- + The equipment requires a mains connection of 220-230 V with 50 Hz mains voltage.
- + The equipment may only be connected directly to an earthed socket using the supplied mains cable. Extension cables must conform to VDE guidelines. Always completely unwind the mains cable.
- + The socket must be protected by a fuse with a minimum fuse rating of "16 A, slow blow".
- + Do not make any changes to the mains cable or the mains plug.
- + Keep the mains cable away from water, heat, oil and sharp edges. Do not route the mains cable underneath the equipment or under a carpet or rug, and do not place any objects on top of it.

1.4 Set-Up Place

⚠ WARNING

- + Do not place the equipment in main corridors or escape routes.

⚠ CAUTION

- + Choose a location in which to place the equipment such that there is enough free space/clearance to the front, the rear and to the sides of the equipment. Make sure that you leave at least 30 cm on each side of the equipment and at least 15 cm in front of and behind the equipment as a training zone. This is the minimum required area in order to safely use the equipment. The recommended free zone around the equipment should be at least 60 cm on each side and 45 cm in front of and behind the equipment.
- + The training room should be well ventilated during training and not be exposed to any draughts.
- + Choose the place in which to set up the equipment such that there is enough free space/clearance to the front, the rear and to the sides of the equipment.
- + The set-up and mounting surface of the equipment should be flat, loadable and solid.

▶ ATTENTION

- + The device may only be used in one building, in sufficiently tempered and dry rooms (ambient temperatures between 10°C and 35°C). The equipment should not be used outdoors or in rooms with high humidity (over 70%) like swimming pools.
- + A floor protective mat/equipment underlay can help to protect high-quality floor coverings (parquet, laminate, cork, carpets) from dents and sweat and can help to level out slight unevenness.

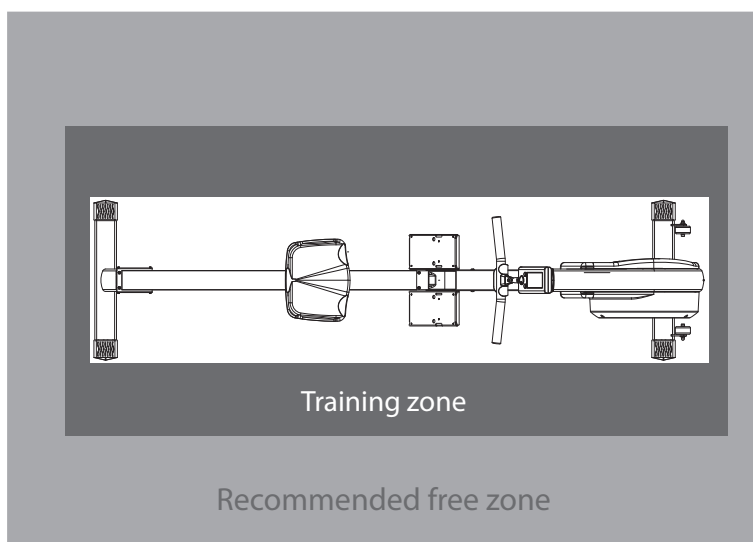

2.1 General Instructions



DANGER

- + Do not leave any tools, packaging materials such as foils or small parts lying around, as otherwise there is a danger of suffocation for children. Keep children away from the equipment during assembly.



WARNING

- + Pay attention to the instructions attached to the equipment in order to reduce the risk of injuries.



CAUTION

- + Ensure to have sufficient room for movement in each direction during assembly.
- + The assembly of the equipment must be carried out by at least two adults. If in doubt, seek the help of a third technically skilled person.



ATTENTION

- + To prevent damage to the equipment and the floor, assemble the equipment on a mat or packaging board.



NOTICE

- + In order to make the assembly as simple as possible, some screws and nuts to be used can already be pre-assembled.
- + Ideally, assemble the equipment at its later set-up place.

2.2 Scope of Delivery

The scope of delivery consist of the following parts. At the beginning, check whether all parts and tools belonging to the device are included in the scope of delivery and whether damage has occurred. In the event of complaints, the contractual partner must be contacted directly.

⚠ CAUTION

If parts of the scope of delivery are missing or damaged, the assembly must not be carried out.

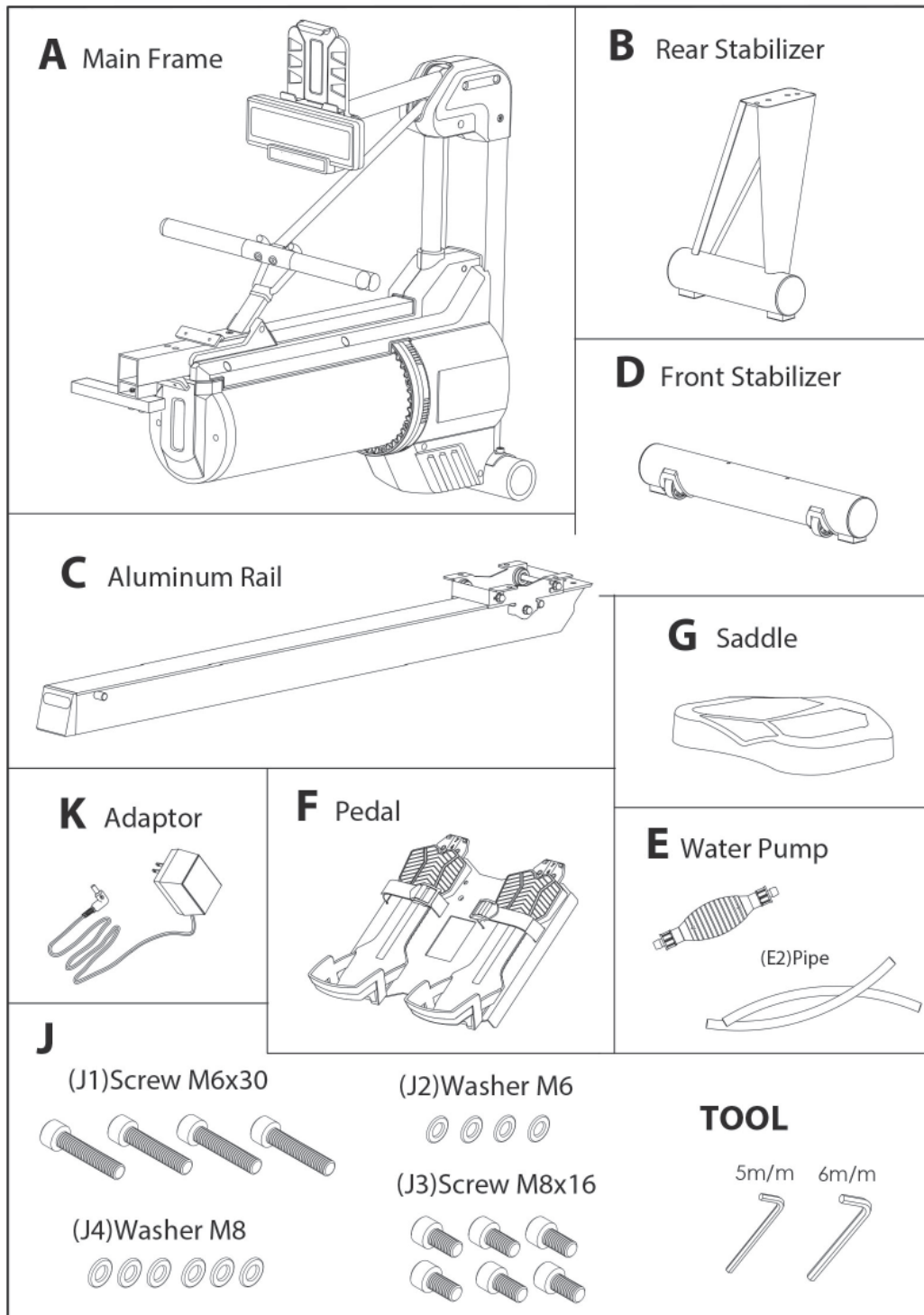

2.3 Assembly

Before assembly, take a close look at the individual assembly steps shown and carry out the assembly in the order given.

① NOTICE

- + First loosely screw all parts together and check that they fit properly. Tighten the screws using the tool only when you are instructed to do so.
- + If you have difficulty recognising the graphics, we recommend that you open and/or download the PDF instructions stored in the webshop on your end device (e.g. smartphone, tablet or PC). There you have the option of zooming in closer. Please note that the Adobe Acrobat Reader programme must be installed on your end device in order to open the file.

Step 1: Checking of the Parts

1. Fold out the bottom carton (fig1-1).
2. Remove the polyfoam (fig1-2).
3. Collect the parts except the main frame (A) and check if they match the parts list.

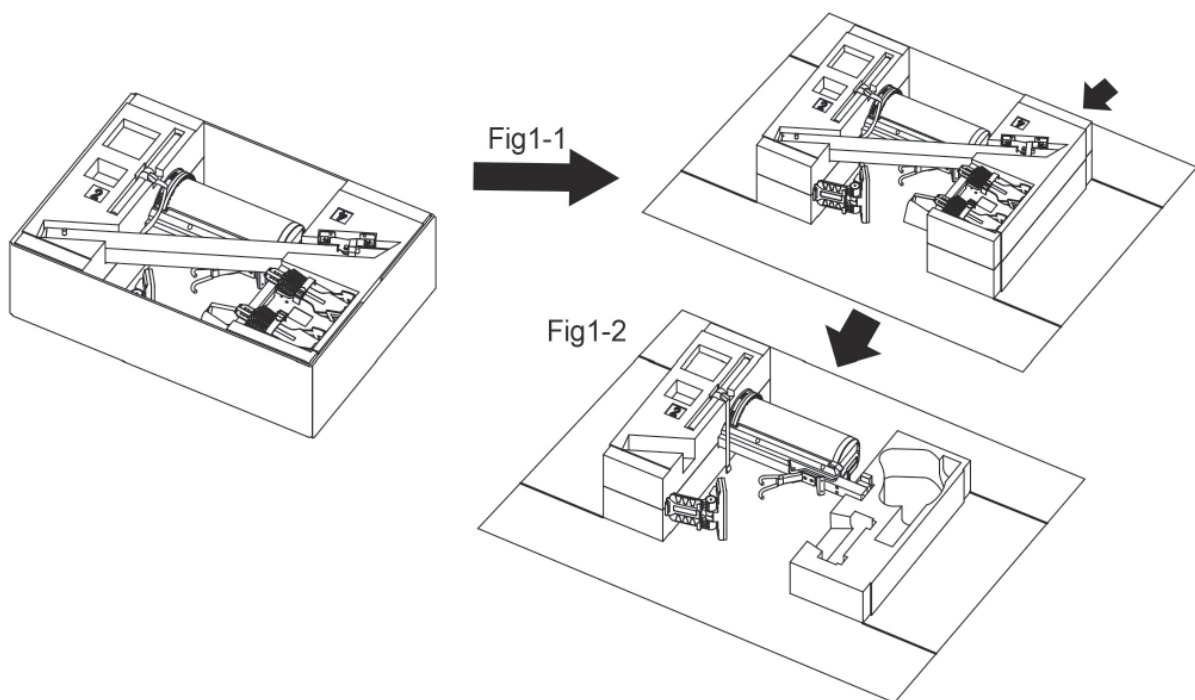

Step2: Disassembly of Tube for Packaging

CAUTION

- + Do not set up the main frame by pulling the water tank.
- + Do not let the water tank touch the ground.

1. Set up the main frame (A) together with the polyfoam.
2. Disassemble the two screws.
3. Remove the tube for packaging.

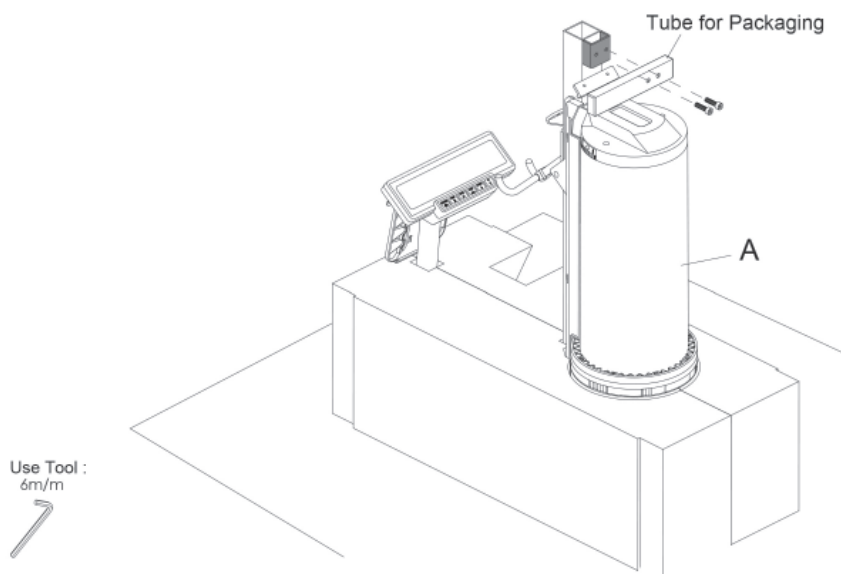

Step 3: Assembly of the Pedal

Assemble the pedal (F) on the main frame (A) by using four screws (J1) and four washers (J2).

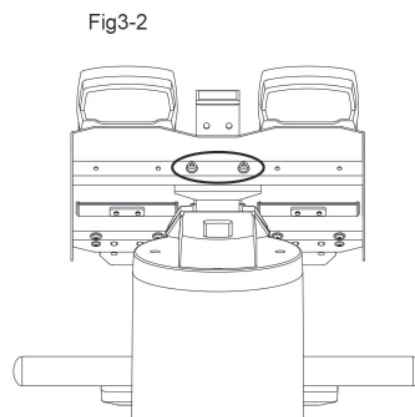
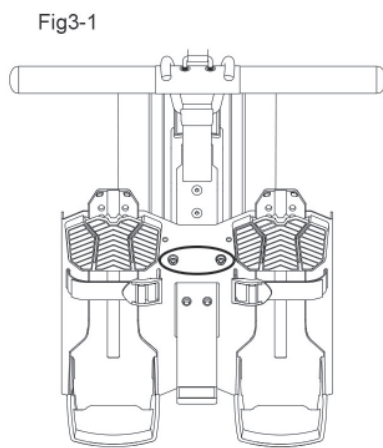
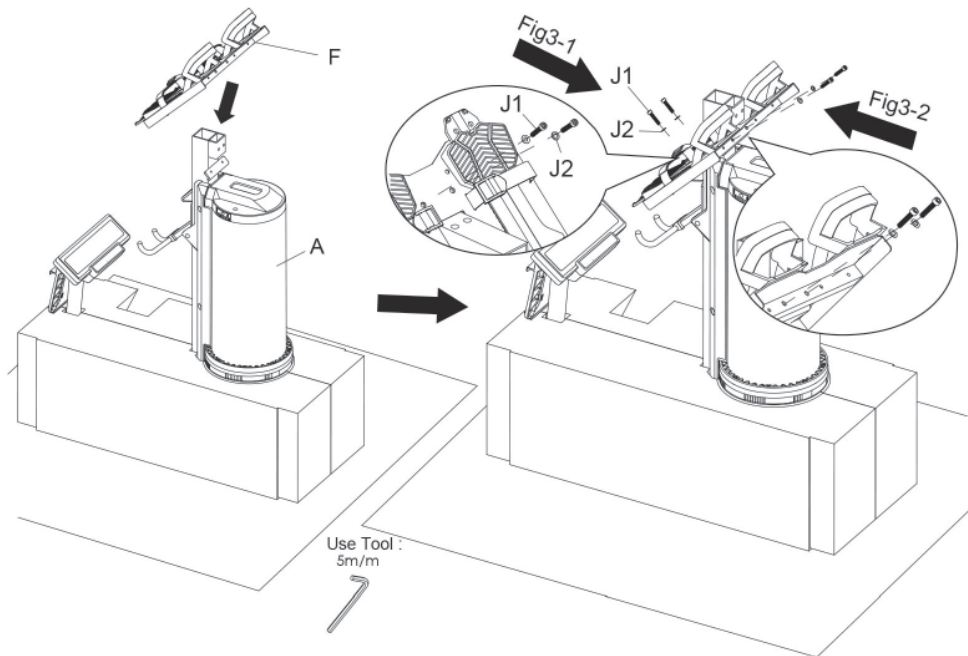

Step 4: Removing of the Polyfoam and Paper Tube

1. Set up the main frame (A) together with the polyfoam and place one polyfoam below the pedal (fig 4-1).
2. Remove the polyfoam from the main frame (A).
3. Remove the strap holder and place the handle bar on the handle bar hanger (fig 4-2).
4. Remove both premounted screws (J3), both washers (J5) and remove the paper tube (fig 4-3).
5. Keep the screws and washers for the next step.

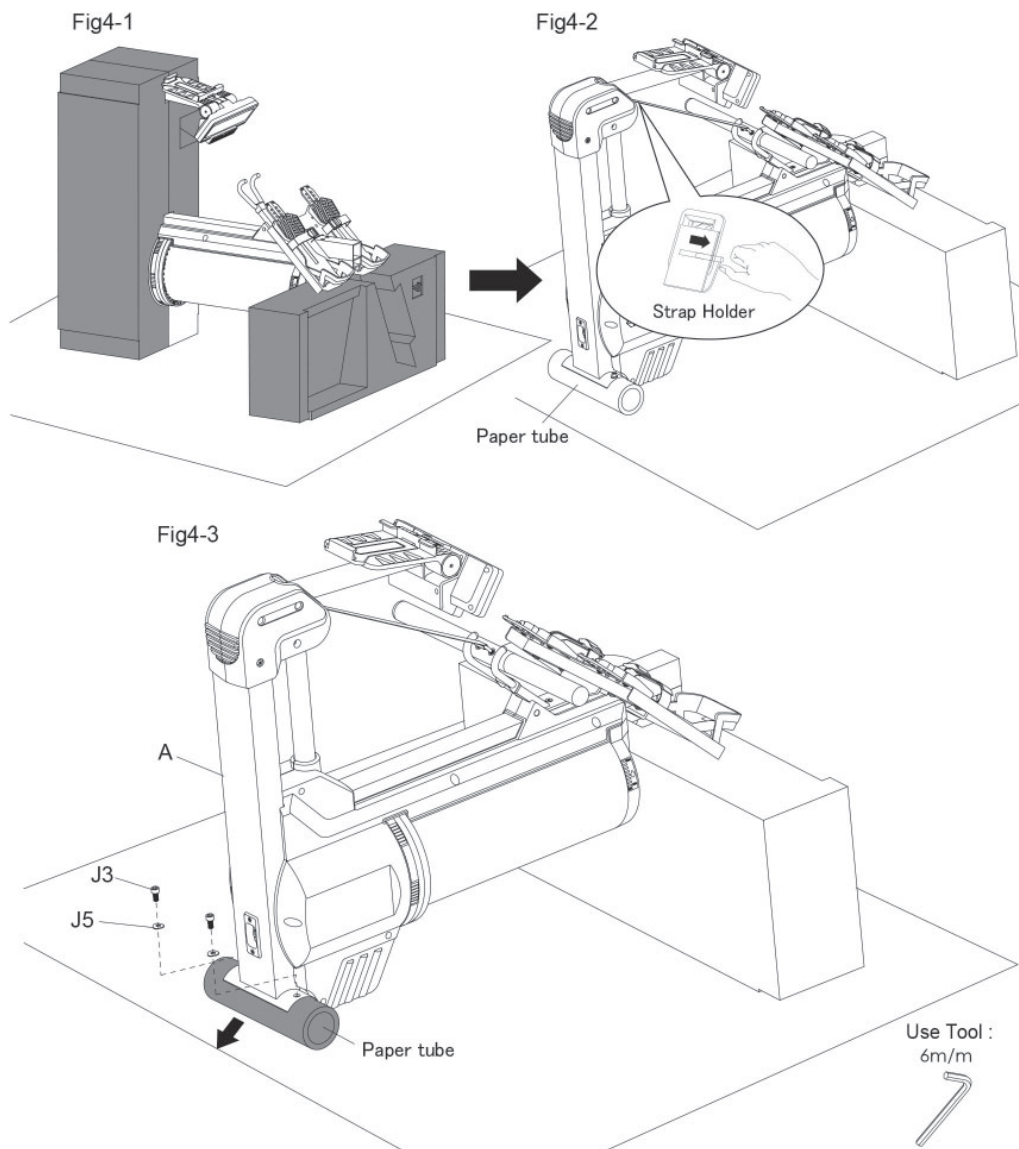

Step 5: Assembly of the Front Stabilizer

Use the two screws (J3) and two washers (J5) from the previous step to assemble the front stabilizer (D) to the main frame (A).

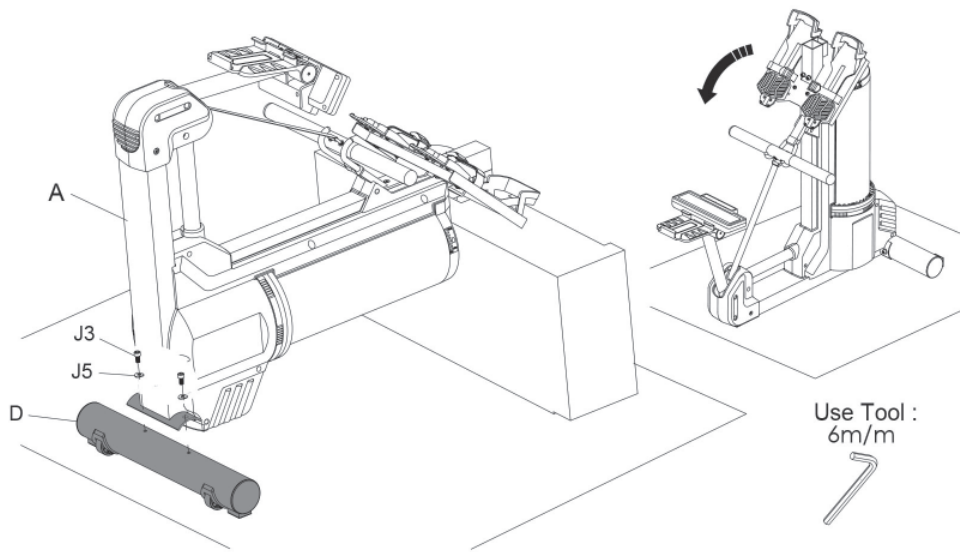

Step 6: Assembly of the Rear Stabilizer

► **ATTENTION**

Be aware of the direction of the rear stabilizer.

Assemble the rear stabilizer (B) on the aluminum rail (C) by using two screws (J3) and two washers (J4).

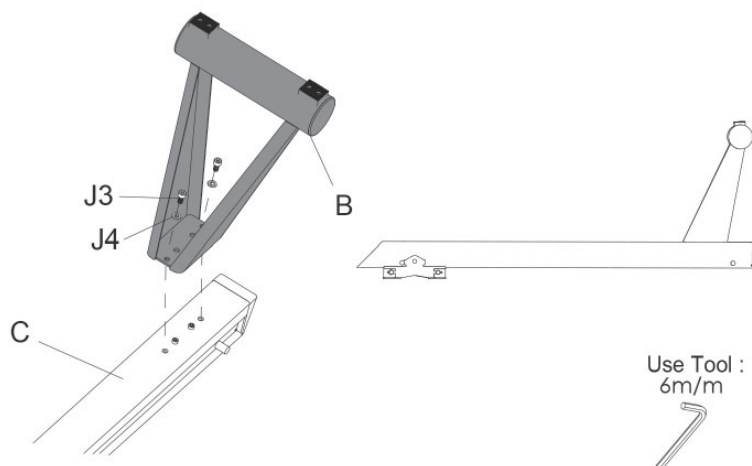

Step 7: Assembly of the Aluminum Rail

CAUTION

Take care that the sliding basement will slide after the strap is cut off.

1. Cut off the strap holding the sliding basement on the aluminum track.
2. Assemble the aluminum rail (C) on the main frame (A) by using four screws (J3) and four washers (J4).

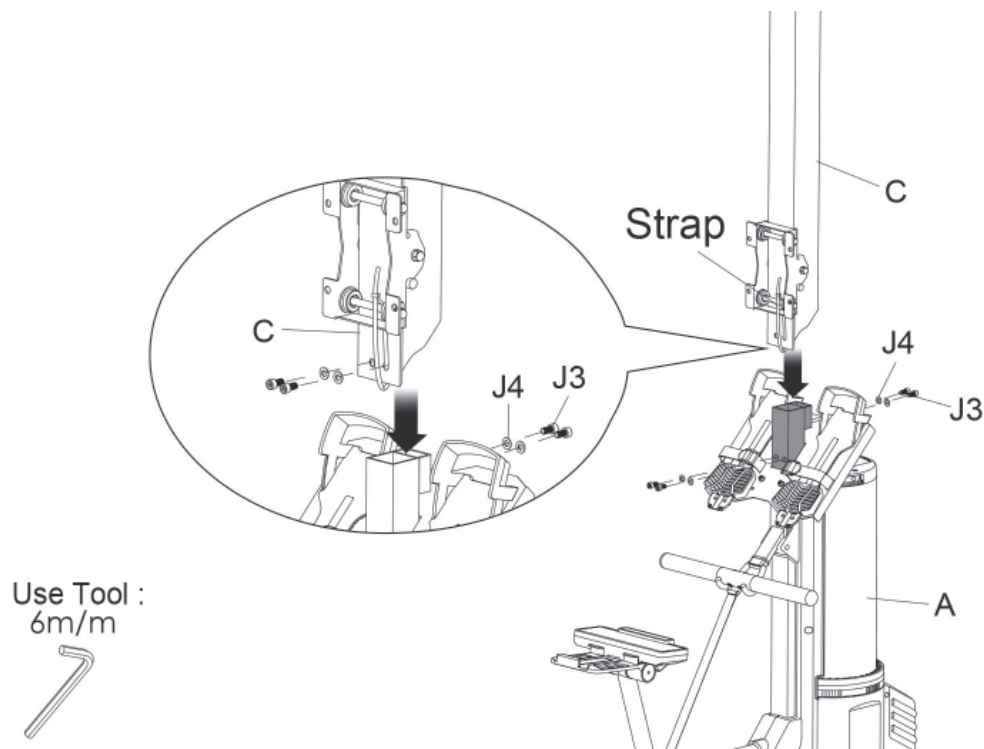

Step 8: Assembly of the Saddle

1. Remove the four premounted screws (J3) and washers (J4) from the saddle.
2. Assemble the saddle (G) on the sliding basement of the aluminum rail (C) by using the previously removed screws and washers.
3. Lay down the rower.
4. Now tighten the screws from the previous steps.

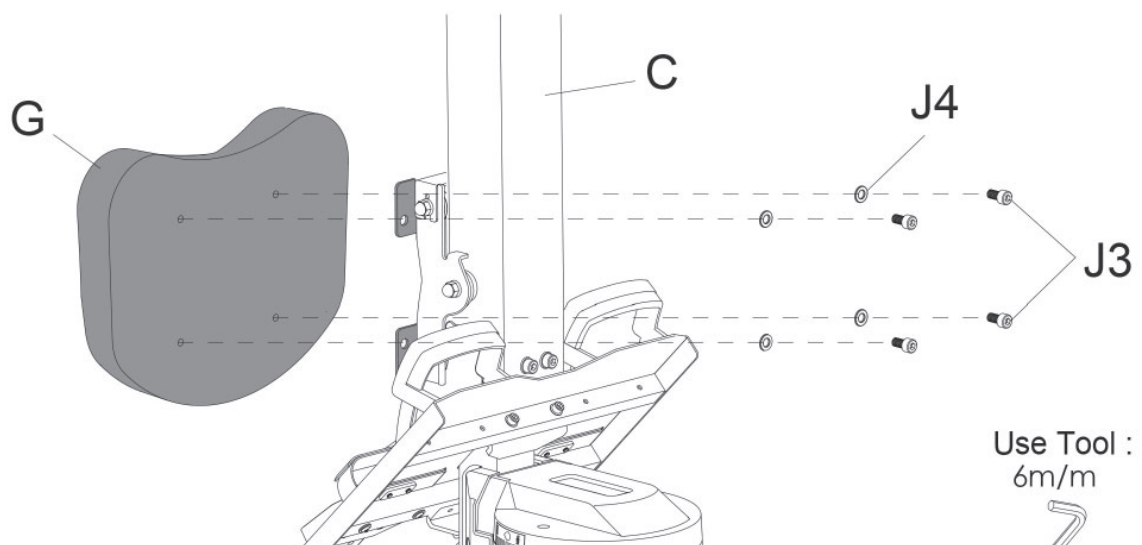

Step 9: Adjustment of the Pedals

You can choose between 7 positions to adjust the pedals.

1. Pull up the two buttons on the pedal at the same time.
2. Move the pedal up or down to the desired position.
3. Release the buttons to let the pedal engage at the desired position.
4. Repeat these steps for the other pedal.
5. Tighten the pedal straps when you are in motion.

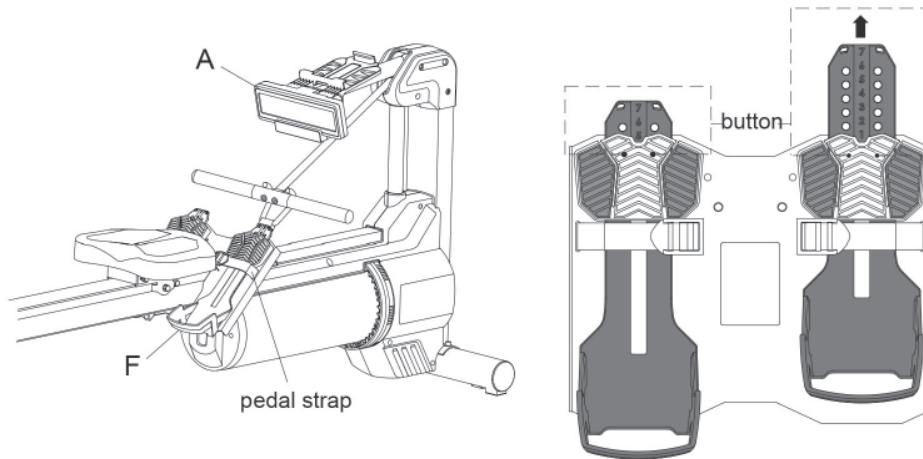

Step 10: Adjustment of the Angles of Console, Console Tube & Smartphone Stand

Adjust the angles as needed and engage the position.

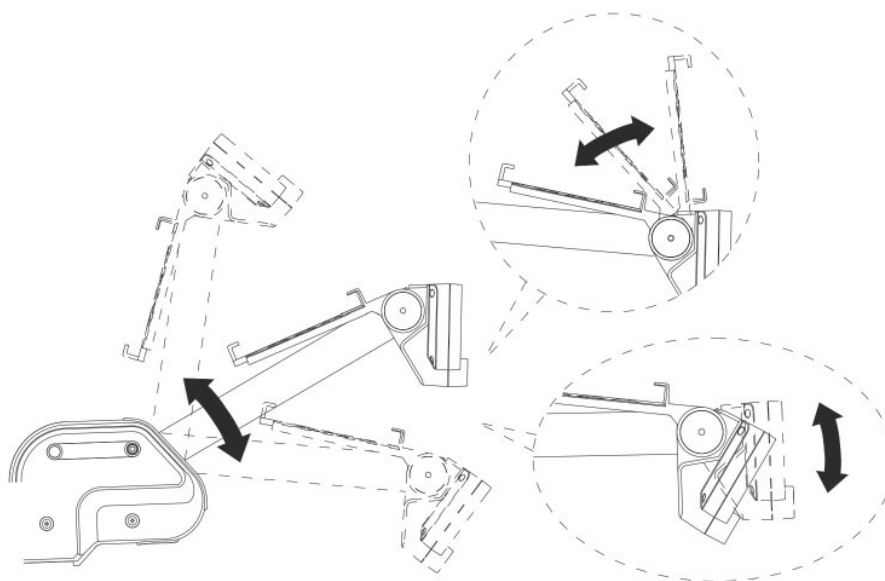

Step 11: Connecting the Equipment to the Mains Supply

► ATTENTION

The equipment must not be connected to a multiple socket, otherwise it cannot be guaranteed that the equipment will be supplied with sufficient power. Technical errors can result.

Plug the power plug (K) into a wall outlet that complies with the instructions in the chapter on electrical safety.

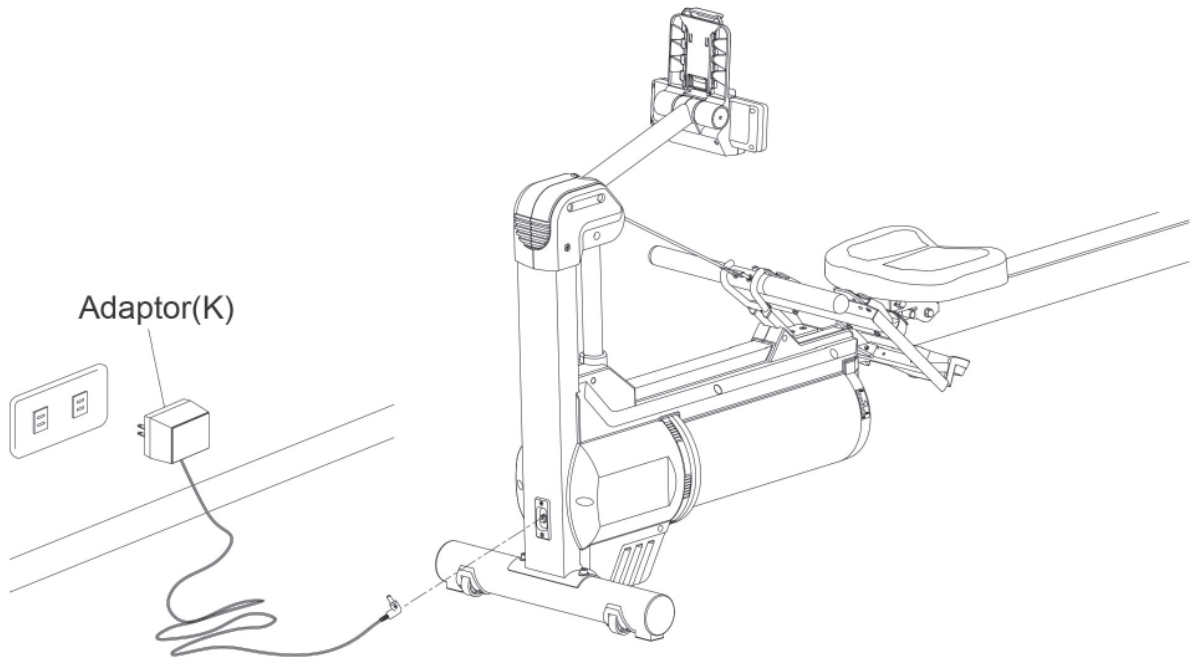

Step 12: Assembly of the Water Pump

NOTICE

The plastic retaining nuts (E1) are premounted on the water pump (E).

1. Turn the two nuts (E1) counterclockwise as far as it will go.
2. Connect the two water pipes (E2) with the water pump (E).
3. Secure the water pipes (E2) on the water pump (E) by turning the nuts (E1) clockwise as far as it will go.

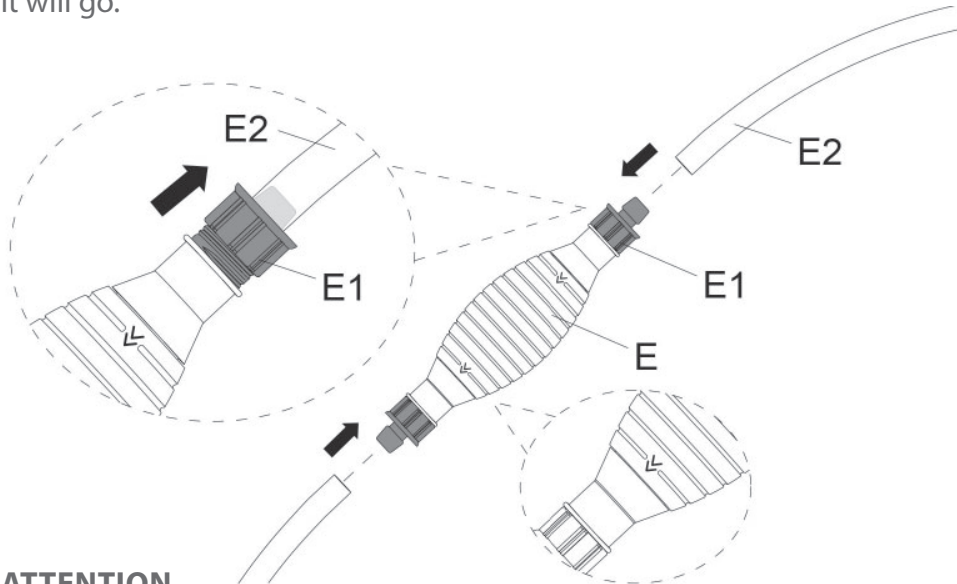

ATTENTION

The arrow on the pump indicates the direction of the water flow.

Recommended Water level

Please follow the instructions on the water level label to fill the water between the Min and Max level.

Maximum capacity: 9.7 litres

Minimum capacity: 7 litres

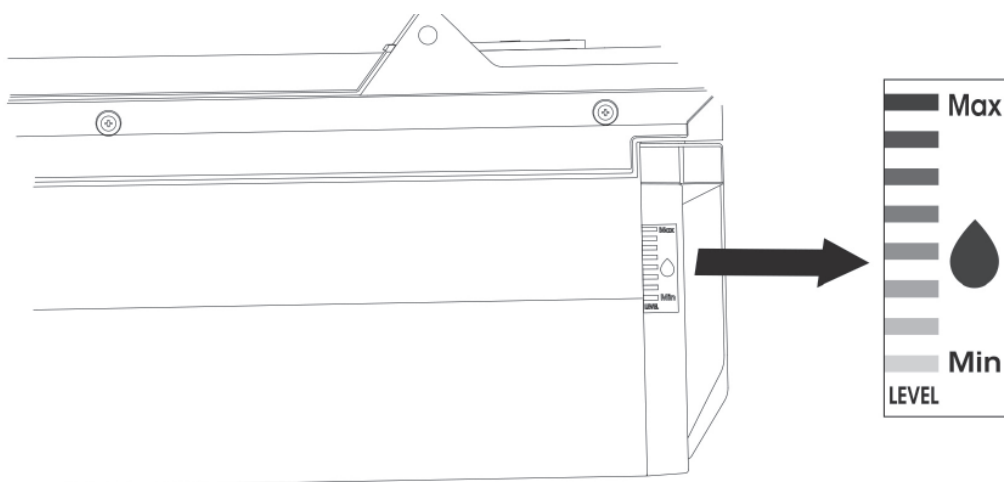

Step 13: Fill the Water Tank



CAUTION

The water inside the tank must not be drunk and must be disposed of after use.

ATTENTION

- + Fill the tank only with tap water. Do not use distilled water.
- + Do not fill the water tank above the maximum capacity, this may void the warranty. The maximum filling quantity can be found in the section on the water level in this chapter.
- + To prevent algae formation, limescale and possible damage to the tank, we recommend the use of chlorine tablets. Only use chlorine tablets for rowing machines.

1. Remove the water tank rear cover, filling cover and the tank plug.
2. Check the water flow direction on the pump (E) and insert the water pipe (E2) into the water tank (the side of the pump where the water comes out).
3. Insert the other pipe of the pump into a container filled with water.
4. Squeeze the pump (E) for several times to pipe the water from the container into the water tank until the water level reaches the recommended level from the label.
5. Attach the tank plug, filling cover and water tank rear cover.

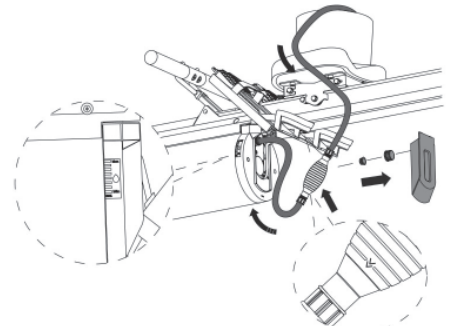

Step 14: Empty the Water Tank

1. Place the rower into an upright position.
2. Insert the water pipe (E2) into the water tank and make sure it touches the bottom of the tank.
3. Insert the other water pipe inside of an empty container.
4. Squeeze the pump (E) for several times to pipe the water out from the tank into the container.

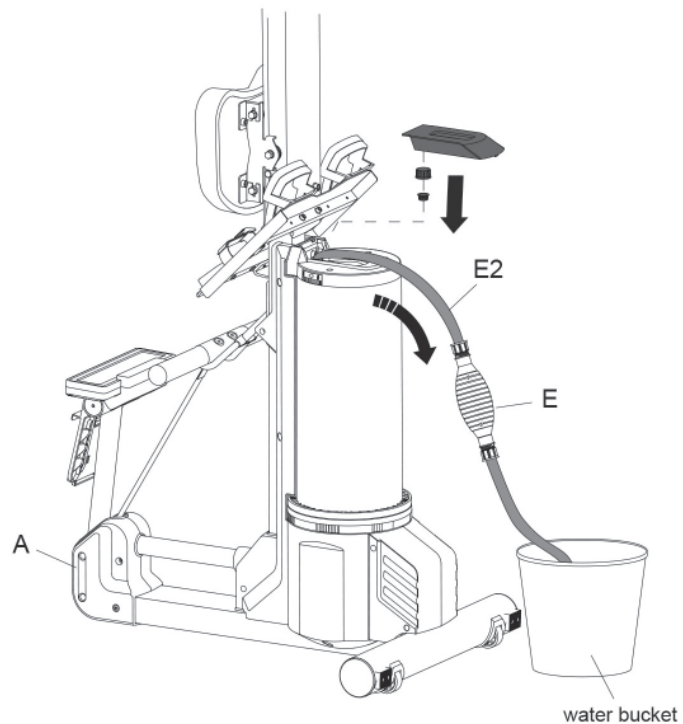

3 OPERATING INSTRUCTIONS

① NOTICE





Familiarise yourself with all the functions and setting options of the device before starting training. Have the proper use of this product explained to you by a specialist.

3.1 Console Display



TIME	+ Displays the training time + Display range: 0:00 - 99:59 minutes
TIME/500M	+ Displays the training time needed to finish 500m of rowing + Display range: 0:00 - 99:59 minutes
TIME/500M AVG	+ Displays the average training time to finish 500m of rowing + Display range: 0:00 - 99:59 seconds
METERS	+ Displays the covered rowing distance + Display range: 0 - 99999 meters
STROKES	+ Displays the number of strokes + Display range: 0 - 9999
SPM	+ Displays the strokes per minute + Display range: 0 - 99
PULSE	+ Displays the pulse beats per minute (BPM) + Display range: 40 - 240
WATTS	+ Displays the current output in watt + Display range: 0 - 9999
WATT AVG	+ Displays the average output in watt + Display range: 0 - 9999
CALORIES	+ Displays your calorie consumption in cal + Display range: 0 - 9999
CALORIES/ HOUR	+ Displays your calorie consumption per hour in cal + Display range: 0 - 9999

3.2 Button Functions

	+ Switching on the console. + Set values to 0.
	Start/interrupt/continue the selected training program.
	+ Confirm or select training program. + Press during training to check training data.
	+ Select program when in standby mode. + Increase or decrease function value.
	Start the recovery function during the training.

3.3 Functions

Switch on the console

After connecting the rowing machine to the mains supply or pressing any button when in standby mode the console is switched on.

Standby Mode

The console gets automatically into standby mode about 60 seconds after the end of the workout.

QUICK START

Pressing START/STOP or pulling the handle will activate QUICK START.

Ending the training

When you have stopped rowing, the console gets into PAUSE mode and resets the values automatically after a few seconds or you press RESET to reset the values.

3.4 Programs

3.4.1 TIME PROGRAM



1. With the console on: Press UP/DOWN until the training mode turns into TIME PROGRAM.
2. Press ENTER.
3. Press UP/DOWN to adjust the TIME to your desired training time.

Default setting is 20 minutes. Each step with the UP/DOWN button is 1 minute.

4. Once you finish adjusting the TIME, press ENTER.
5. Press START/STOP to start the training.

The TIME will count down during the training.

6. Press START/STOP to pause the training.
7. Press START/STOP to continue the training.

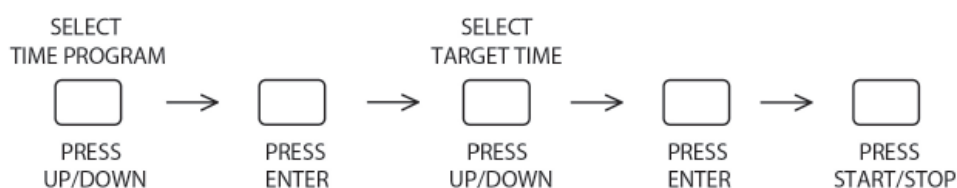

3.4.2 METERS PROGRAM

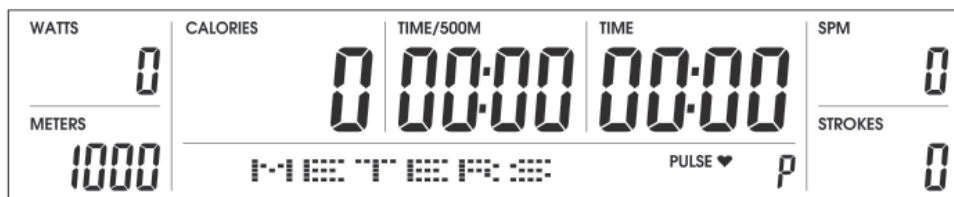

1. With the console on: press UP/DOWN until the training mode turns into METERS PROGRAM.
2. Press ENTER.
3. Press UP/DOWN to adjust the METERS to your desired training distance.

Default setting is 1000 meters. Each step with the UP/DOWN button is 100 meters.

4. Once you finish adjusting the METERS, press ENTER.
5. Press START/STOP to start the training.

The METERS will count down during the training.

6. Press START/STOP to pause the training.
7. Press START/STOP to continue the training.

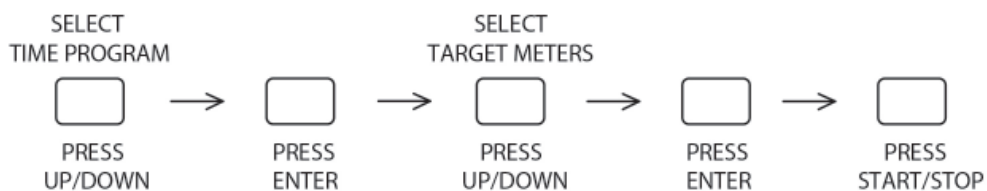

3.4.3 CALORIES PROGRAM

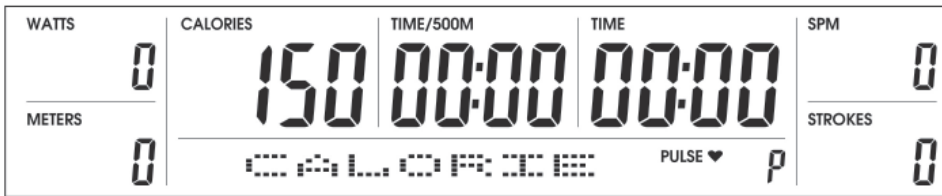

1. With the console on: press UP/DOWN until the training mode turns into CALORIES PROGRAM.
2. Press ENTER.
3. Press UP/DOWN to adjust the CALORIE to your desired training calories.

Default setting is 150 cal. Each step with the UP/DOWN button is 10 cal.

4. Once you finish adjusting the CALORIES, press ENTER.
5. Press START/STOP to start the training.

The CALORIES will count down during the training.

6. Press START/STOP to pause the training.
7. Press START/STOP to continue the training.

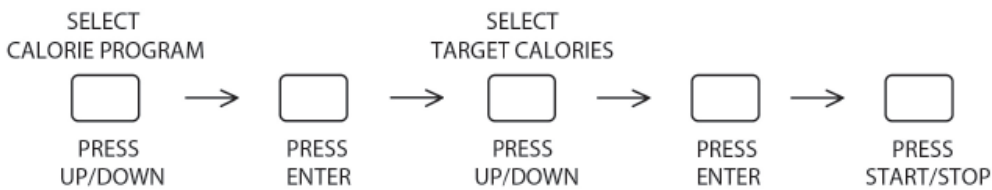

3.4.4 STROKES PROGRAM

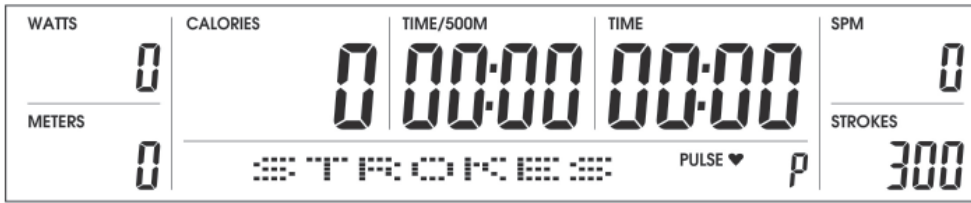

1. With the console on: press UP/DOWN until the training mode turns into STROKES PROGRAM.
2. Press ENTER.
3. Press UP/DOWN to adjust the STROKES to your desired training strokes.

Default setting is 300 strokes. Each step with the UP/DOWN button is 10 strokes.

4. Once you finish adjusting the STROKES, press ENTER.
5. Press START/STOP to start the training.

The STROKES will count down during the training.

6. Press START/STOP to pause the training.
7. Press START/STOP to continue the training.

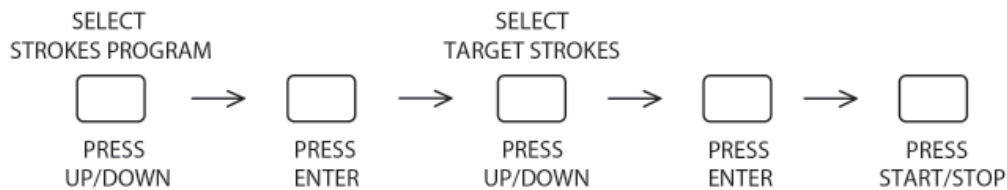

3.4.5 INTERVAL 20/10 PROGRAM



1. With the console on: press UP/DOWN until the training mode turns into INT 20/10 PROGRAM.
2. Press ENTER.
3. Press UP/DOWN to adjust the CYCLE to your desired training cycle.

Default setting is 10 cycles. Each step with the UP/DOWN button is 1 cycle. Each CYCLE includes 20-second-train and 10-second-rest.

4. Once you finish adjusting the CYCLE, press ENTER.
5. Press START/STOP to start the training.

The CYCLE will count down during the training.

6. Press START/STOP to pause the training.
7. Press START/STOP to continue the training.

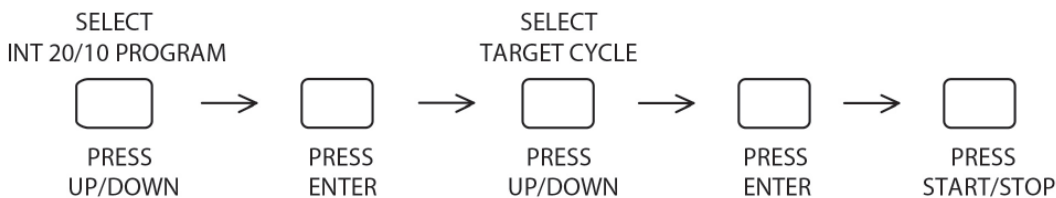

3.4.6 INTERVAL 20/30 PROGRAM

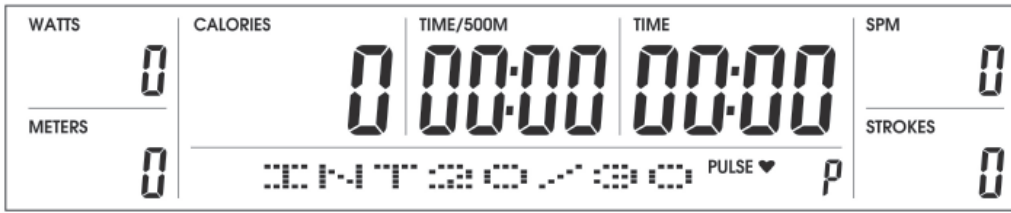

1. With the console on: press UP/DOWN until the training mode turns into INT 20/30 PROGRAM.
2. Press ENTER.
3. Press UP/DOWN to adjust the CYCLE to your desired training cycle.

Default setting is 10 cycles. Each Step with the UP/DOWN button is 1 cycle. Each CYCLE includes 20-second-train and 30-second-rest.

4. Once you finish adjusting the CYCLE, press ENTER.
5. Press START/STOP to start the training.

The CYCLE will count down during the training.

6. Press START/STOP to pause the training.
7. Press START/STOP to continue the training.

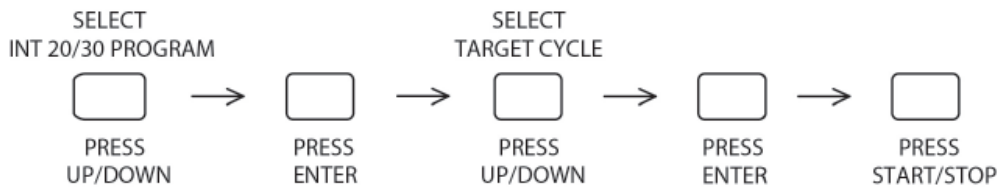

3.4.7 INTERVAL CUST PROGRAM



1. With the console on: press UP/DOWN until the training mode turns into INT CUST PROGRAM.
2. Press ENTER.
3. Press UP/DOWN to adjust the WORK TIME to your training time of each CYCLE.

Default setting is 20 seconds. Each step with the UP/DOWN button is 1 second.

4. Press ENTER and then press UP/DOWN to adjust the REST TIME to your resting time of each CYCLE.

Default setting is 10 seconds. Each step with the UP/DOWN button is 1 second.

5. Press ENTER and then press UP/DOWN to adjust the CYCLE to your desired training cycle.

Default setting is 10 cycles. Each step with the UP/DOWN button is 1 cycle.

6. Press ENTER and then press START/STOP to start the training.

*Each CYCLE includes your adjusted WORK TIME and REST TIME.
The CYCLE will count down during the training.*

7. Press START/STOP to pause the training.
8. Press START/STOP to continue the training.

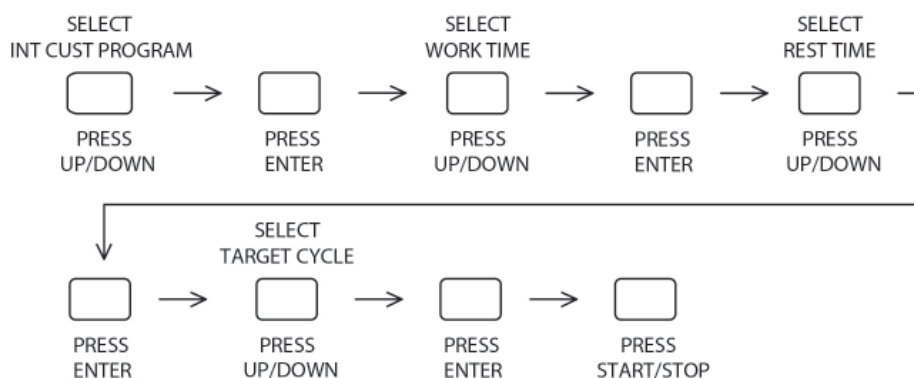

3.4.8 SPM PROGRAM



1. With the console on: press UP/DOWN until the training mode turns into SPM PROGRAM.
2. Press ENTER.
3. Press UP/DOWN to adjust the SPM to your desired training strokes in 1 minute.

Default setting is 30 strokes. Each step with the UP/DOWN button is 1 stroke.

4. Press ENTER and then press START/STOP to start the training.
5. Press START/STOP to pause the training.
6. Press START/STOP to continue the training.

During the training, the console will show the following:

*If SPM is lower than the SPM you set, it will show **FASTER**.*

*If SPM is higher than the SPM you set, it will show **SLOWER**.*

*If SPM is equal to the SPM you set, it will show **GREAT**.*

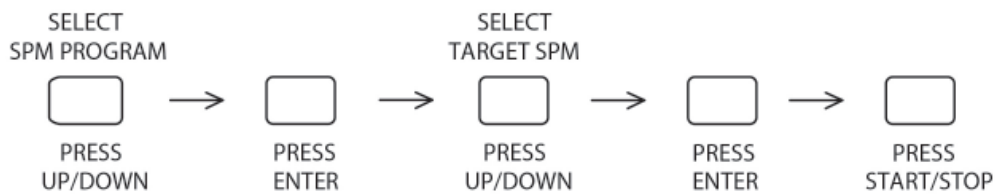

3.4.9 Race Program

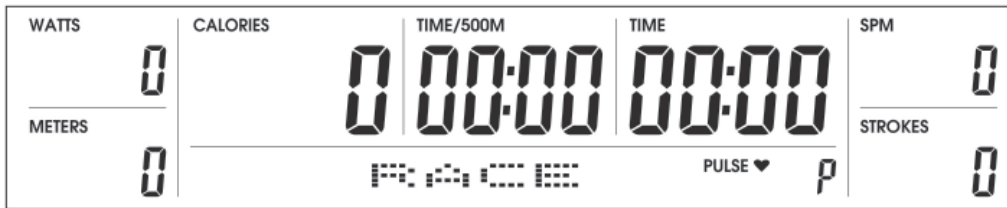

1. With the console on: press UP/DOWN until the training mode turns into RACE PROGRAM.
2. Press ENTER.
3. Press UP/DOWN to adjust the computer's rowing pace.

HIGH-TIME/500M: 02:15
MEDIUM-TIME/500M: 03:00
LOW-TIME/500M: 03:30
CUSTOM-TIME/500M: Set by yourself. Default setting is 3 minutes. Each step is 1 second.

4. Press ENTER and then press UP/DOWN to adjust the distance of the race (METERS).

Default setting is 500 METERS. Each step with the UP/DOWN button is 100 METERS.

5. Press ENTER and then press START/STOP to start the training.
6. Press START/STOP to pause the training.
7. Press START/STOP to continue the training.

You control the Y ship. Computer controls the C ship.

YOU WIN if you finish the race first. Otherwise, it shows YOU LOSE.

While the race ends, the console shows:

YOU WIN: if you finish the race first.

YOU LOSE: if you finish the race last.

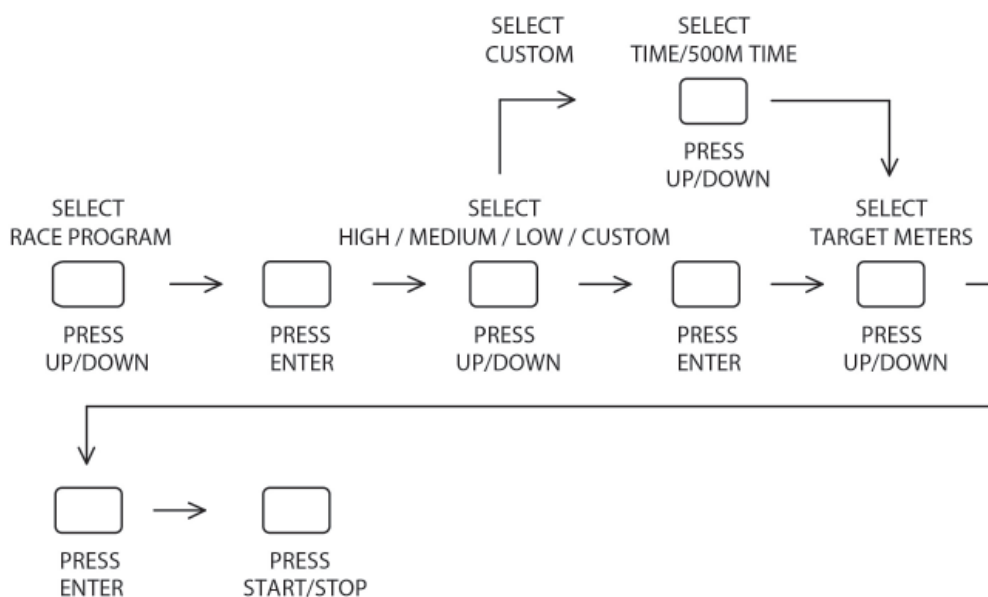

3.4.10 Heart Rate Controlled Program

⚠ WARNING

Your training equipment is not a medical device. The heart rate measurement of this equipment may be inaccurate. Various factors can affect the accuracy of the heart rate measurement. The heart rate measurement serves only as a training aid.

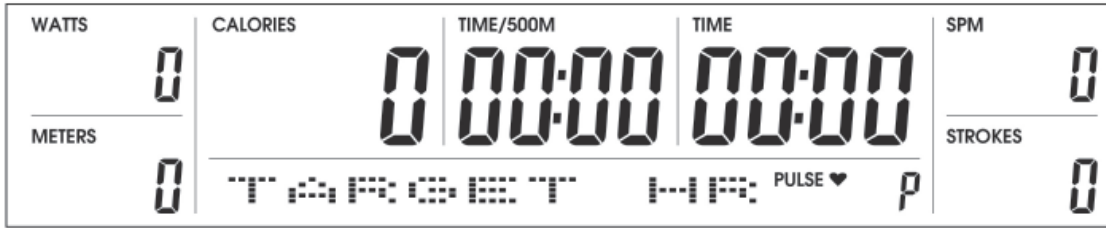

1. With the console on: press UP/DOWN until the training mode shows TARGET HR PROGRAM.
2. Press ENTER.
3. Press UP/DOWN to adjust the HR to your desired training heart rate (HR).

Default setting is 130 BPM. Each step with the UP/DOWN button is 5 BPM.

4. Press ENTER and then press UP/DOWN to adjust your desired HR training interval.

Default setting is 30 SPM. Each step with the UP/DOWN button is 5 SPM.

5. Press ENTER and then press START/STOP to start the training.
6. Press START/STOP to pause the training.
7. Press START/STOP to continue the training.

During the training, the console will show the following:

- SPEED UP:** If HR is lower than the HR you set.
- SLOW DOWN:** If HR is higher than the HR you set.
- GOOD:** If HR is higher than HR interval for 2 minutes, training stops for 30 seconds.

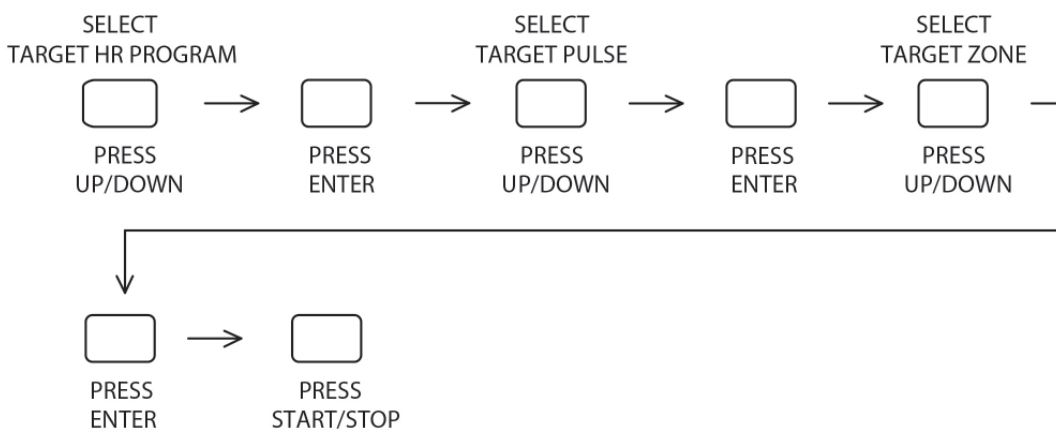

3.4.11 Recovery Program

Recovery program is activated by pressing the Recovery button.

1. Under Each Program: Press RECOVERY to detect the Heart Rate Recovery Function.

After pressing RECOVERY: a 60 seconds countdown is shown.

If the console hasn't received a heart rate signal for 10 seconds, it will turn into REC: FAIL.

If the console hasn't received a heart rate signal for 20 seconds, it will stop.

After 60 seconds countdown, it will show the result:

Result	Fitness level
F1	Very good
F2	Good
F3	Average
F4	Sufficient
F5	Poor
F6	Very poor

3.5 5.3 KHZ Chest Belt /Bluetooth Chest Belt

NOTICE

There is no chest belt included.

When wearing the chest belt it will send the heart rate signal.

If the console receives the heart rate signal, the heart rate will be shown on the console.

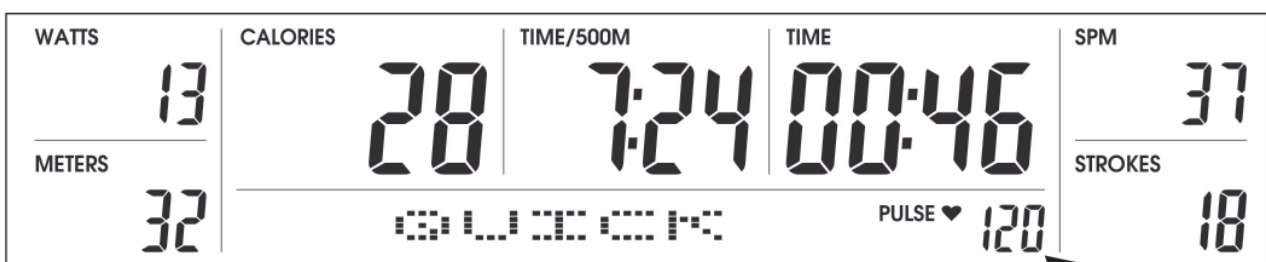

3.6 Bluetooth and fitness apps

This console is equipped with a bluetooth interface. To use training apps you will have to connect your equipment with your mobile device (tablet or smart phone). To do this, please activate the bluetooth function on your mobile device. Now choose your equipment.

Please take note that your mobile device needs to be compatible with the bluetooth interface of the rowing machine (Bluetooth 4.0). Now start the fitness app. It might happen that you need to connect both the app and the console additionally. To do this, please follow the instructions given in the app.

You will find the fitness apps in the app stores of Google or Apple. There you will find the app „Kinomap“. Please note that these apps are produced by an external manufacturer. Sport-Tiedje does not take any responsibility regarding the availability, functionality or contents of these programmes.

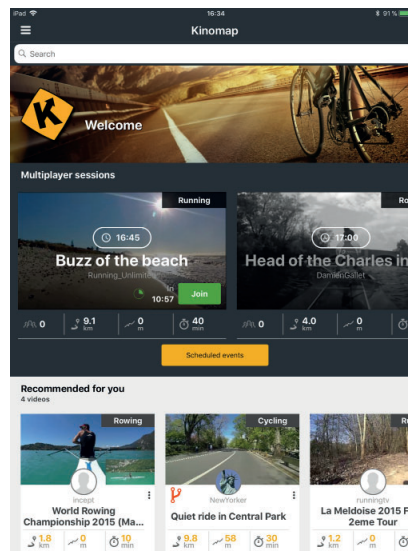
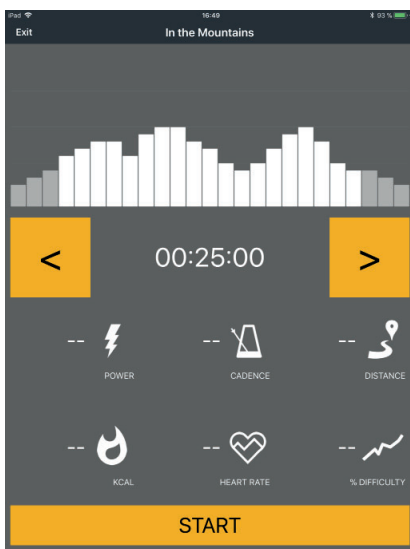
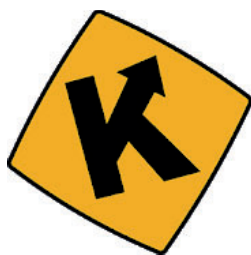

Example: Kinomap

3.7 Notes on correct rowing

Body moves towards the handle

Wrong

At the end of the movement, the body will be pulled forwards towards the handles instead the handles to the body.

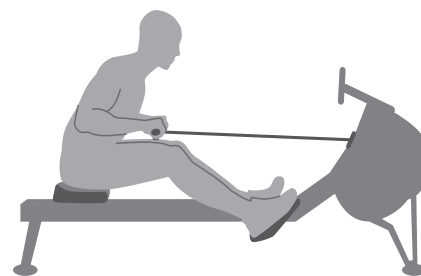

Right

At the end of the movement, the user slightly leans back, holds the legs down, keeps the upper body straight and pulls the handle to the body.

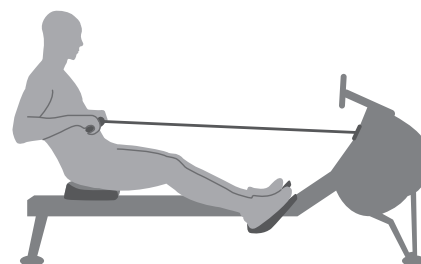

Straddled elbows

Wrong

The user's elbows are straddled from the body at the end of the movement and the handle is at the height of the breast.

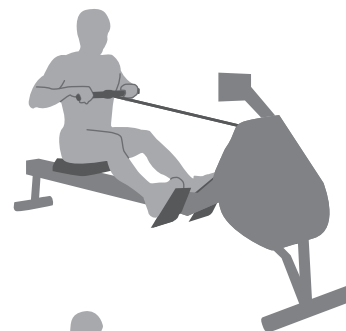

Right

Pull the handle to the body with straight wrists and the elbows close to the body. The elbows are brought behind the head while the handle is pulled to your waist.



Do not completely extend

Wrong

At the end of the movement, the user completely stretches the leg and knee.

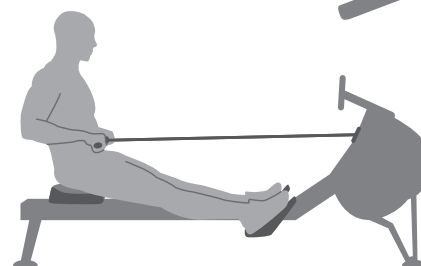

Right

Keep your knee slightly bent at all times even at the end of the movement instead of stretching it completely.

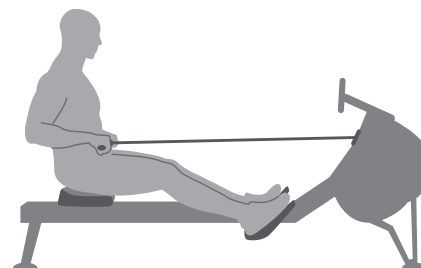

Leaning too far forward

Wrong

The body is bent too far forward. The shins are no longer vertical. The head and shoulders are facing the feet. The body is therefore in a weak position to execute the movement.

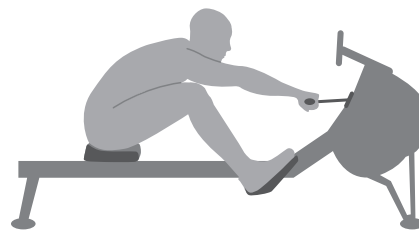

Right

The shins are vertical. The body is pressed against the legs, the arms are completely stretched out in front and the body is slight bent forward. This position should be pleasant.

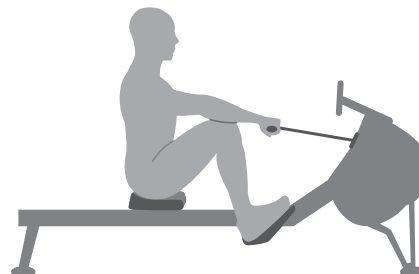

Rowing with bent arms

Wrong

The user begins the movement with the arms instead of first pressing with the legs.

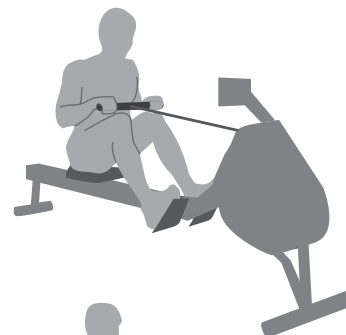

Right

The user begins by stretching out the legs, relaxing the back and stretching the arms.



Bent wrists

Wrong

The user bends the wrists during the movement.

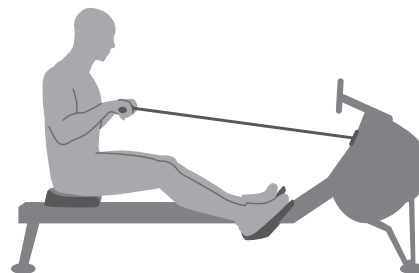

Right

Always execute the rowing movement with straight wrists.

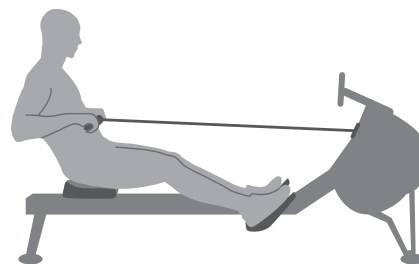

4.1 General Instructions

⚠ WARNING

- + The storage location should be chosen so that improper use by third parties or children can be prevented.
- + If your equipment does not have transportation wheels, the equipment must be disassembled before transportation.

▶ ATTENTION

- + Make sure that the equipment is protected from moisture, dust and dirt in the selected storage location. The storage location should be dry and well ventilated and have a constant ambient temperature between 10°C and 35°C.

4.2 Transportation Wheels

▶ ATTENTION

If you want to transport your equipment over particularly sensitive and soft floor coverings, such as parquet, planks or laminate, lay out the transport route with cardboard or similar to avoid possible floor damage.

1. Stand behind the equipment and lift it until the weight is transferred to the transportation wheels. After that, you easily can move the equipment to a new position. For long transport distances the equipment should be disassembled and safely packed.
2. Select the new location by following the instructions in the section 1.4 of this manual.

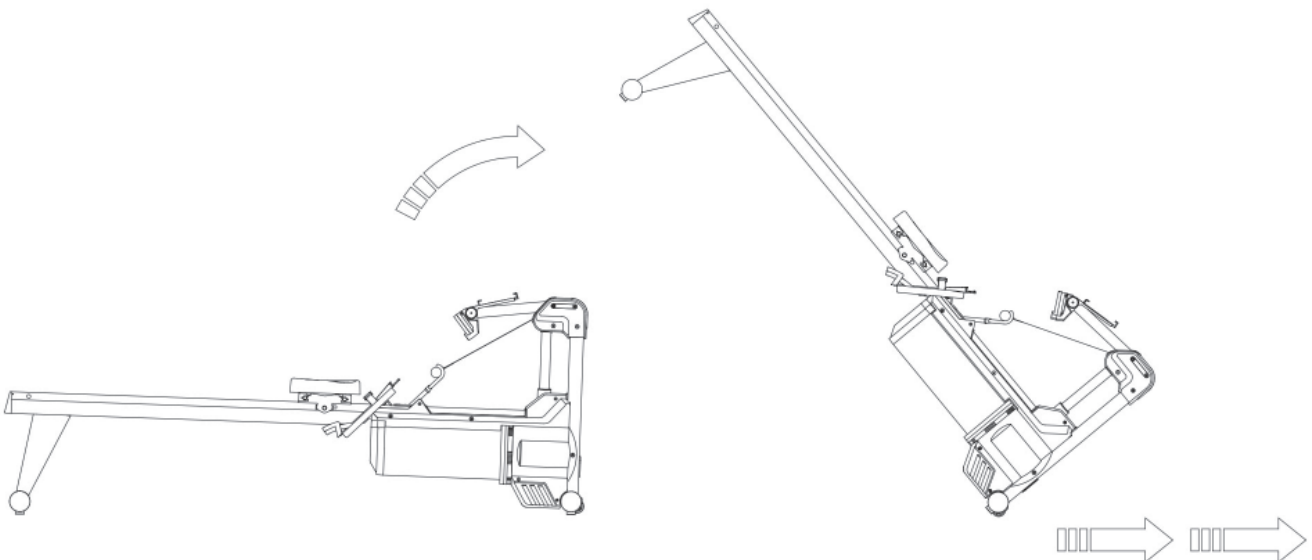

5.1 General Instructions



WARNING

- + Do not make any improper changes to the equipment.



CAUTION

- + Damaged or worn components may affect your safety and the life of the equipment. Therefore, immediately replace damaged or worn components. In such a case, contact the contract partner. The equipment must not be used until it has been repaired. If necessary, use only original spare parts.

ATTENTION

- + In addition to the instructions and recommendations for maintenance and care given here, additional service and/or repair work may be necessary; this must only be carried out by authorised service technicians.

5.2 Faults and Fault Diagnosis

The equipment undergoes regular quality controls during production. Nevertheless, faults or malfunctions may occur. Frequently, individual parts are responsible for these disturbances, an exchange is usually sufficient. Please refer to the following overview for the most common errors and how to correct them. If the equipment still does not function properly, contact your contract partner.

Fault	Cause	Solution
Heart rate is not received	<ul style="list-style-type: none"> + Sources of interference in the room + unsuitable chest strap + Wrong position of chest strap + Batteries empty 	<ul style="list-style-type: none"> + Eliminate sources of interference (e.g. mobile phones, loudspeakers, WLAN, lawn mower and vacuum cleaner robots...) + Use a suitable chest strap (see recommended accessories). + Reposition chest strap and/or moisten electrodes + Changing batteries
LCD error – software error etc.	Console has no power supply	<ul style="list-style-type: none"> + Hold Reset to start the console again. + Start the console again by disconnecting the power cable for about 15 seconds. + Disconnect and connect again all cable connections, see assembly instructions. + Contact a service technician of your contract partner.
Squeaking noises on the guide rails	Guide rails or rollers dirty or guide rails dry	Clean the guide rails and then lubricate them with a suitable lubricant

5.3 Error Codes and Troubleshooting

The electronics of the equipment continuously carries out tests. In case of deviations, an error code appears on the display and normal operation is stopped for your safety.

Please contact the contract partner for technical support.

5.4 Maintenance and Inspection Calendar

To avoid damage from body sweat, the equipment must be cleaned with a damp towel (no solvents!) after each training session.

The following routine tasks must be performed at the specified intervals:

Part	Weekly	Monthly	Quarterly	Half-yearly
Display console	C	I		
Cleaning and lubrication of slide rail and moving parts*		C/I		
Cushions	C			
Plastic covers	C	I		
Screws and cable connections		I		
Water colour/Chlorine**				I
Legend: C = clean; I = inspect				

*Make sure to always clean the slide rails and moving parts before re-lubricating.

** To avoid algae formation and deposits in the tank, chlorine tablets must be used regularly. This should be done approx. every 3-6 months and depends, among other things, on the direct sunlight. In general, the brighter the set-up location, the more frequently you must put a chlorine tablet into the tank. The water does not need to be changed.

Water colour for rowing machines can be purchased as an optional accessory to colour the water in the water tank. Please note that the water colour already contains chlorine. Therefore, do not use water colour with additional chlorine tablets, as these neutralise the colour.

6 DISPOSAL

At the end of its operational life, this equipment cannot be disposed of in normal household waste. Instead, it must be disposed of via an electricals recycling centre. Further information can be obtained from your local authority's recycling service.



The materials can be recycled as per their symbols. Through the reuse, recycling of materials or other forms of recovery of old equipment, you make an important contribution to the protection of the environment.

7 RECOMMENDED ACCESSORIES

To make your training experience even more efficient and pleasant, we recommend that you add suiting accessories to your fitness equipment. For rowing machines this could for example be a **floor mat**, which makes your fitness equipment stand more securely and also protects the floor from sweat or **silicone spray** to keep moving parts in good shape. We also recommend the use of **rowing gloves**. For rowing machines with water resistance, be sure to purchase chlorine tablets.

If you have purchased a fitness machine with pulse training and want to train your heart rate, we strongly recommend that you use a compatible **chest strap**, as this ensures optimum transmission of the heart rate.

Our range of accessories offers the highest quality and makes training even better. If you would like to find out more about compatible accessories, please go to the detail page of the product in our webshop (the easiest way is to enter the article number in the search field above) and go to the recommended accessories on this page. Of course, you can also contact our customer service: by telephone, e-mail, in one of our branches or via our social media channels. We will be happy to advise you!



floor mat



chest strap



chest strap contact gel



rowing gloves



silicone spray

8.1 Serial Number and Model Name

In order to provide you with the best possible service, please have the model name, article number, serial number, exploded drawing and parts list ready. The corresponding contact options can be found in chapter 10 of this operating manual.

NOTICE

The serial number of your equipment is unique. It's located on a white sticker. The exact position of this sticker is shown in the following illustration.



Enter the serial number in the appropriate field.

Serial number:

Brand / Category:

cardiostrong / rowing machine

Model Name:

Aquastream

Article Number:

CST-AS

8.2 Parts List

No.	Name	Qty.
A1	FRAME	1
A2	PULLEY COVER (L)	1
A3	PULLEY COVER (R)	1
A4	CHAIN COVER (L)	1
A5	CHAIN COVER (R)	1
A6	HEX SOCKET HEAD CAP SCREW M6x65mm	5
A9	WASHER M6xΦ16x1.5T	5
A10	STRAP PULLEY	1
A11	BEARING 6000ZZ	2
A12	SLEEVE Φ10xΦ6.2x48.8mm	1
A13	C CLIP	2
A14	HANDLEBAR HANGER	1
A16	HEX SOCKET FLAT HEAD CAP SCREW M6X12mm	2
A17	DECORATION TUBE	1
A18	STRAP WHEEL SUPPORT PILLAR Φ15xΦ6x30.5mm	2
A18-1	HEX SOCKET HEAD CAP SCREW M6x40mm	2
A19	HEX SOCKET HEAD CAP SCREW M8x10mm	1
A20	DC POWER SUPPLY COVER	1
A22	COUNTERSUNK HEAD PHILLIPS TAPPING SCREWS M4x12mm	2
A23	PRESSING PIPE HANGER	1
A24	WASHER Φ8xΦ25x3T	1
A25	HEX HEAD CAP SCREW M8x25mm	1
A26	NUT M8	1
A27	WASHER M10x2Tx16	3
A28	BEARING 6000ZZ(TPX-Z3)	2
A29	HEX HEAD CAP SCREW M10x30mm	1
A31	STRAP WHEEL SIDE PLATE (R)	1
A32	STRAP WHEEL SIDE PLATE (L)	1
A33	AXLE	1
A34	STRAP GUIDING WHEEL	1
A35	BEARING 608ZZ(TPX)	2

A36	C CLIP E6	2
A37	TRUSS HEAD PHILLIPS SCREWS M5x10mm	2
A38	TRUSS HEAD PHILLIPS SCREWS M5x6mm	12
A39	TRUSS HEAD PHILLIPS SCREWS M5x10mm	3
A40	TRUSS HEAD PHILLIPS SCREWS M6x12mm	2
A41	WASHER $\Phi 6 \times \Phi 16 \times 1.5T$	2
A42	HEX SOCKET HEAD CAP SCREW M6x30mm	1
A43	HEX NUT M6	1
A44	BEARING 6201ZZ	2
A45	BEARING 6202ZZ	2
A46	SPRING BOX	1
A47	C CLIP S20	1
A48	STEEL PLATE WASHER	1
A49	AXLE M6	1
A50	MAGNET $\Phi 6 \times 5T$	6
A51-B	ONE-WAY STRAP PULLEY	1
A52	BELT WHEEL	1
A53	BELT PULLEY CONNECTOR	1
A54	CROSS SECTION CONNECTOR	1
A55	AXLE $\Phi 19 \times 142mm$	1
A56	BELT PULLEY 32x24	1
A57	BELT 190J8	1
A58	FRONT COVER OF WATER TANK	1
A59-1	BUSHING $\Phi 25 \times \Phi 40 \times 10mm(NOK)$	1
A59-2	BUSHING $\Phi 25 \times \Phi 40 \times 10mm(TPO)$	1
A60	BLOCKING RING	1
A61	BEARING 6005ZZ	1
A62	C CLIP	1
A63	WATER TANK FIXING PLATE	2
A64	WATER TANK	1
A65	PLUG	1
A66	WATER TANK CAP	1
A67	REAR COVER OF WATER TANK	1
A68	COUNTERSUNK HEAD PHILLIPS TAPPING SCREWS M4x10mm	2

A69	TRUSS HEAD PHILLIPS SCREWS M4x12mm	2
A70	MAGNET Ø5x3T	2
A71	WATER TANK CAP COVER	1
A72	AXLE Ø25x485mm	1
A73	WATER TANK CONNECTOR	1
A74	PROPELLER	3
A75-1	CONNECTION RING	2
A75-2	CONNECTION RING	2
A76	HEX SOCKET HEAD CAP SCREW M6x10mm	4
A77	BUSHING Ø25xØ28x20L	1
A78	PLUG	1
A79	O RING Ø177.17x5.33T	2
B	REAR STABILIZER	1
B1	FIXING PLATE	1
B2	TRUSS HEAD PHILLIPS TAPPING SCREWS M4x12mm	4
C	SLIDING TRACK	1
C2	REAR COVER OF SLIDING TRACK	1
C3	ROUND HEAD PHILLIPS SCREWS M2x6mm	2
C4	DOUBLE HEAD SCREW Ø5.25x85mm	2
C5	STOP BLOCK Ø14x22mm	4
D	FRONT STABILIZER	1
D2	TRANSPORTATION WHEEL Ø76.2	2
D3	FEET 40x32mm	4
D4	SIDE COVER Ø76.2	4
E	DRUM PUMP	1
E1	NUT	2
E2	PIPE	2
F	PADDLE	1
F2	ADJUSTABLE PADDLE	2
F3	PLASTIC MAT	2
F4	PADDLE STRAP	2
F5	TRUSS WASHER HEAD TAPPING SCREW M4x8mm	4
F7	TRUSS HEAD PHILIPPS TAPPING SCREWS M4x25mm	4
F8	FIXING PLATE	2

F9	COUNTERSUNK PHILIPPS SCREWS M5x10mm	4
G	SADDLE	1
G1	SADDLE SIDE PLATE	2
G2	WHEEL PROTECTION PLATE	2
G3	AXLE	2
G4	WHEEL	6
G5	WASHER $\Phi 8 \times \Phi 12 \times 2 \text{mm}$	6
G6	BEARING 608ZZ(BMC)	6
G7	WASHER M8x $\Phi 16 \times 2.0 \text{T}$	6
G8	HEX CAP NUT M8	6
G9	SCREW M8x20mm	2
H	CONSOLE	1
H2	CONSOLE TUBE	1
H3	CONSOLE STAND	1
H4	SMART DEVICE STAND	1
H5	TURNING AXLE COVER	2
H6	AXLE COVER	4
H7	HEX SOCKET HEAD CAP SCREW M6x75mm	1
J1	HEX SOCKET HEAD CAP SCREW M6x30mm	4
J2	WASHER M6x $\Phi 13 \times 1 \text{T}$	4
J3	HEX SOCKET HEAD CAP SCREW M8x16mm	20
J4	WASHER M8x $\Phi 16 \times 1.5 \text{T}$	18
J5	ARC WASHER $\Phi 8 \times \Phi 19 \times 1.5 \text{T}$	2
J6	HEX SOCKET HEAD CAP SCREW M6x10mm	2
J7	TRUSS HEAD PHILLIPS TAPPING SCREWS M4x12mm	18
J8	TRUSS HEAD PHILLIPS TAPPING SCREWS M4x19mm	5
J9	HEX NUT M6	14
J10	HEX SOCKET HEAD CAP SCREW M6x16mm	20
J11	WASHER $\Phi 6 \times \Phi 13 \times \Phi 1 \text{T}$	8
J12	CLINCH NUTS	2
K	ADAPTOR	1
L1	PACKAGING TUBE	1
L2	SIDE COVER 20x40mm	2
L3	HEX SOCKET HEAD CAP SCREW M8x30mm	2

L5	STRAP HOLDER	1
L6	WATER LEVEL STICKER	1
L7	DECORATION STICKER	5
L8	STICKER	1
L9	FOAM	3
M1-B	HANDLEBAR	1
M2	FOAM	2
M6	SIDE COVER Φ 28.6	2
M7	ALUMINUM HANDLE COVER	1
M8	IRON BUCKLE	1
M9	T SHAPE SCREW	2
M10	NUT M6X Φ 16X15mm	2
N1	WIRE 400mm	1
N2	DC LINE 620mm	1
N3	WIRE620mm	1
N4	WIRE300mm	1
N5	SENSOR WIRE 6x25x150mm	1

8.3 Exploded Drawing

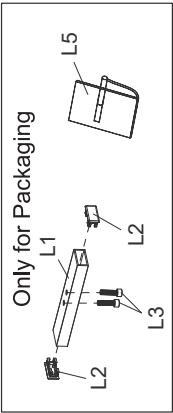
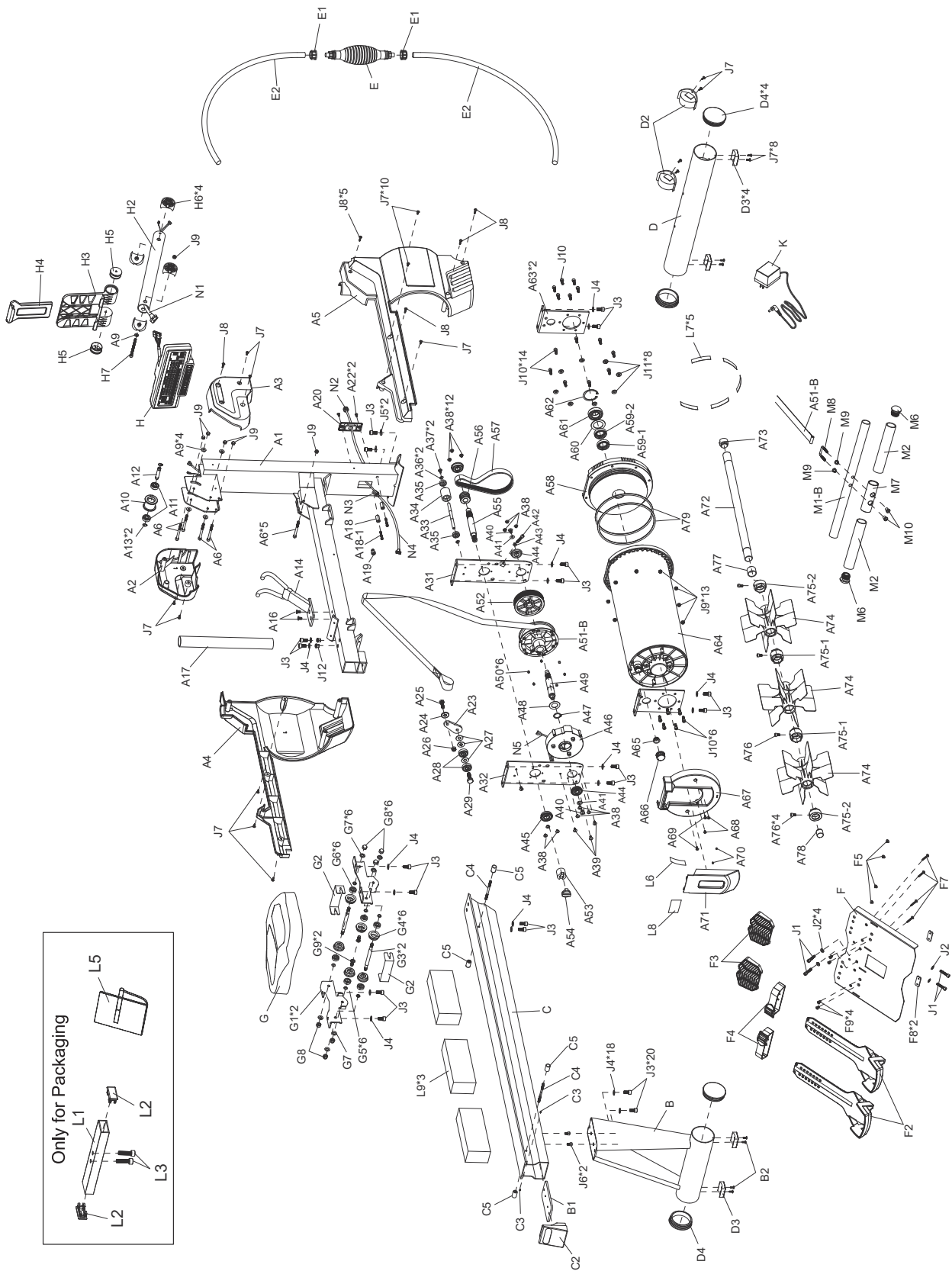

Training equipment from cardiostrong® is subject to strict quality control. However, if a fitness equipment purchased from us does not work perfectly, we take it very seriously and ask you to contact our customer service as indicated. We are happy to help you by phone via our service hotline.

Error Descriptions

Your fitness equipment is developed for long-term, high-quality training. However, should a problem arise, please first read the operating instructions. For further assistance, please contact your contract partner or call our service hotline. To ensure your problem is solved as quickly as possible, please describe the defect as exactly as possible.

In addition to the statutory warranty, we provide a warranty for every fitness equipment purchased from us according to the following provisions.

Your statutory rights are not affected.

Warranty

The warranty is the first/original buyer and/or any person who received a newly purchased product as a gift from the original buyer.

Warranty period

The warranty periods, shown on our web shop, begin on delivery of the fitness equipment. The respective warranty periods for your equipment can be found on its product website.

Repair Costs

According to our choice, there will either be a repair, a replacement of individual damaged parts or a complete replacement. Spare parts, that have to be mounted while assembling the equipment, have to be replaced by the warranty personally and are not a part of repair. After the expiration of the warranty period for repair costs, a pure parts warranty applies, which does not include the repair, installation and delivery costs.

The terms of use are defined as follows:

- + Home use: solely for private use in private households up to 3 hours per day
- + Semi-professional use: up to 6 hours per day (e. g. rehabilitation centres, hotels, clubs, company gyms)
- + Professional use: more than 6 hours per day (e. g. commercial gyms)

Warranty Service

Within the warranty period, equipment which develops faults as a result of material or manufacturing defects, will be repaired or replaced at our discretion. Ownership of equipment or parts of equipment which have been replaced is transferred to us. The warranty period is not extended nor does a new warranty period begin following repair or replacement under the warranty.

Warranty Conditions

For the warranty to be valid, the following steps must be taken:

Please contact our customer service by email or phone. If the product under warranty has to be sent in for repair, the seller bears costs. After expiry of the warranty, the buyer bears the costs of transport and insurance. If the fault is covered by our warranty, you will receive a new or repaired equipment in return.

Warranty claims are invalid in case of damage resulting from:

- + misuse or improper handling
- + environmental influences (moisture, heat, electrical surge, dust, etc.)
- + failure to follow the current safety measures for the equipment
- + failure to follow the operating instructions
- + use of force (e. g. hitting, kicking, falling)
- + interventions which were not carried out by one of our authorized service centres
- + unauthorized repair attempts

Proof of Purchase and Serial Number

Please make sure that you are able to provide the appropriate receipt when claiming on your warranty. So that we can clearly identify the model of your equipment, and for the purposes of our quality control, you will need to give the serial number of your equipment, when contacting the service team. Where possible please have your serial number and your customer number ready when you call our service hotline. It will help us to deal with your request swiftly.







































If you cannot find the serial number on your fitness equipment, our service team is at your disposal to offer further information.

Service outside of the Warranty Period

We are also happy to issue an individual cost estimate if there is a problem with your fitness equipment after the warranty has expired, or in cases which do not fall under the terms of the warranty, e. g. normal wear and tear. Please contact our customer service team to find a quick and cost-effective solution to your problem. In such a case you will be responsible for the delivery costs.

Communication

Many problems can be solved just by speaking to us as your specialist supplier. We know how important it is to you as a user of the fitness equipment to have problems solved quickly and simply, so you can enjoy working out with minimal interruption. For that reason, we also want to resolve your queries quickly and in a straightforward manner. Thus, please always keep your customer number and the serial number of the faulty equipment handy.

DE	DK	FR
<p>TECHNIK</p> <p> +49 4621 4210-900</p> <p> +49 4621 4210-698</p> <p> technik@sport-tiedje.de</p> <p> Öffnungszeiten entnehmen Sie unserer Homepage.</p>	<p>TEKNIK OG SERVICE</p> <p> 80 90 16 50</p> <p>+49 4621 4210-945</p> <p> info@fitshop.dk</p> <p> Åbningstider kan findes på hjemmesiden.</p>	<p>TECHNIQUE & SERVICE</p> <p> +33 (0) 189 530984</p> <p>+49 4621 42 10 933</p> <p> info@fitshop.fr</p> <p> Vous trouverez les heures d'ouverture sur notre site Internet.</p>
<p>SERVICE</p> <p> 0800 20 20277 (kostenlos)</p> <p> 04621 4210 - 0</p> <p> info@sport-tiedje.de</p> <p> Öffnungszeiten entnehmen Sie unserer Homepage.</p>	<p>PL</p> <p>DZIAŁ TECHNICZNY I SERWIS</p> <p> 22 307 43 21</p> <p>+49 4621 42 10-948</p> <p> info@fitshop.pl</p> <p> Godziny otwarcia można znaleźć na stronie głównej.</p>	<p>BE</p> <p>TECHNIQUE & SERVICE</p> <p> 02 732 46 77</p> <p>+49 4621 4210 933</p> <p> info@fitshop.be</p> <p> Vous trouverez les heures d'ouverture sur notre site Internet.</p>
UK	NL	INT
<p>CUSTOMER SUPPORT</p> <p> 00800 2020 2772</p> <p>+494621 4210 944</p> <p> info@sport-tiedje.co.uk</p> <p> You can find the opening hours on our homepage.</p>	<p>TECHNISCHE DIENST & SERVICE</p> <p> +31 172 619961</p> <p> service@fitshop.nl</p> <p> De openingstijden vindt u op onze homepage.</p>	<p>TECHNICAL SUPPORT & SERVICE</p> <p> +49 4621 4210-944</p> <p> service-int@sport-tiedje.de</p> <p> You can find the opening hours on our homepage.</p>
ES	AT	CH
<p>TECNOLOGÍA Y SERVICIOS</p> <p> 911 238 029</p> <p> info@fitshop.es</p> <p> Consulta nuestro horario de apertura en la página web.</p>	<p>TECHNIK & SERVICE</p> <p> 0800 20 20277 (Freecall)</p> <p>+49 4621 42 10-0</p> <p> info@sport-tiedje.at</p> <p> Öffnungszeiten entnehmen Sie unserer Homepage.</p>	<p>TECHNIK & SERVICE</p> <p> 0800 202 027</p> <p>+49 4621 42 10-0</p> <p> info@fitshop.ch</p> <p> Öffnungszeiten entnehmen Sie unserer Homepage.</p>

Please find a detailed overview including address and opening hours for all stores of the Sport-Tiedje Group in Germany and abroad on the following website:

www.sport-tiedje.com/en/stores

WE LIVE FITNESS

WEBSHOP AND SOCIAL MEDIA

Sport-Tiedje is Europe's largest specialist store for home fitness equipment with currently over 70 stores and one of the world's most renowned online mail order companies for fitness equipment. Private customers order via the 25 web shops in the respective national language or have their desired equipment assembled on site. In addition, the company supplies fitness studios, hotels, sports clubs, companies and physio practices with professional equipment for endurance and strength training.

Sport-Tiedje offers a wide range of fitness equipment from renowned manufacturers, high-quality in-house developments and comprehensive services, such as a build-up service and sports scientific advice before and after the purchase. The company employs numerous sports scientists, fitness trainers and competitive athletes.

Visit us also on our social media platforms or our blog!



www.sport-tiedje.co.uk
www.sport-tiedje.de/blog



www.facebook.com/SportTiedje



www.instagram.com/sporttiedje



www.youtube.com/user/sporttiedje

TAURUS

 cardiostrong

BODYCRAFT

 cardiojump

 **DUKEFITNESS**

DARWIN

