

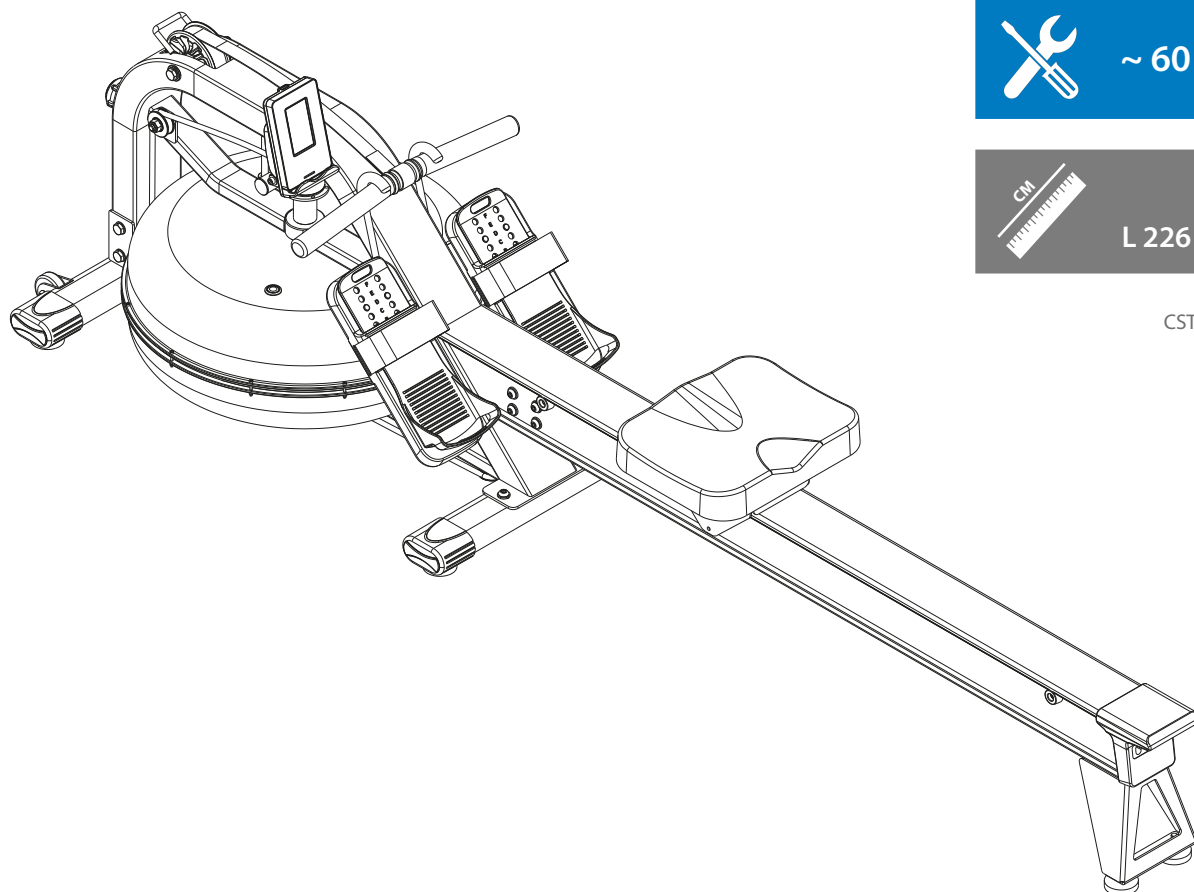

## Assembly and Operating Instructions



max. 150 kg



~ 60 Min. 



 35 kg

L 226 | B 55 | H 65

CSTBALTIC2BT.01.01

Art. No. CST-BALTIC-2BT

Rowing Machine **BALTIC**



# Content

<b>1</b>	<b>GENERAL INFORMATION</b>	<b>7</b>
1.1	Technical Data	7
1.2	Personal Safety	8
1.3	Electrical Safety	9
1.4	Set-Up Place	10
<b>2</b>	<b>ASSEMBLY</b>	<b>11</b>
2.1	General Instructions	11
2.2	Scope of Delivery	12
2.3	Assembly	14
<b>3</b>	<b>OPERATING INSTRUCTIONS</b>	<b>19</b>
3.1	Console Display	19
3.2	Button Functions	20
3.3	Programs	21
3.3.1	Manual Program/Quick-Start Program	21
3.3.2	Interval Programs	21
3.3.3	Target Programs	22
3.4	Notes on correct rowing	23
<b>4</b>	<b>STORAGE AND TRANSPORT</b>	<b>25</b>
4.1	General Instructions	25
4.2	Transportation Wheels	25
<b>5</b>	<b>TROUBLESHOOTING, CARE AND MAINTENANCE</b>	<b>26</b>
5.1	General Instructions	26
5.2	Faults and Fault Diagnosis	26
5.3	Maintenance and Inspection Calendar	27
<b>6</b>	<b>DISPOSAL</b>	<b>27</b>
<b>7</b>	<b>RECOMMENDED ACCESSORIES</b>	<b>28</b>

<b>8</b>	<b>ORDERING SPARE PARTS</b>	<b>29</b>
8.1	Serial Number and Model Name	29
8.2	Parts List	30
8.3	Exploded Drawing	34
<b>9</b>	<b>WARRANTY</b>	<b>35</b>
<b>10</b>	<b>CONTACT</b>	<b>37</b>

**Dear customer,**

thank you for choosing fitness equipment from cardiostrong®. cardiostrong offers high-quality home fitness equipment that is optimally adapted to the conditions at home. Train at home no matter what the weather or time of the day. cardiostrong fitness equipment offers training programmes and a variety of equipment for all training levels and all training goals. Further information can be found at [www.sport-tiedje.com](http://www.sport-tiedje.com) or [www.cardiostrong.de](http://www.cardiostrong.de). We hope you enjoy your training!

Further information can be found at [www.sport-tiedje.com](http://www.sport-tiedje.com).

**Intended Use**

The equipment may only be used for its intended purpose.

The equipment is only suitable for home use. The equipment is not suitable for semi-professional (e.g. hospitals, associations, hotels, schools, etc.) and commercial or professional use (e.g. fitness studios).

**Legal Notice**

Sport-Tiedje GmbH  
Europe's No. 1 for home fitness

International Headquarters  
Flensburger Straße 55  
24837 Schleswig  
Germany

Management:  
Christian Grau  
Sebastian Campmann  
Dr. Bernhard Schenkel  
No. HRB 1000 SL  
Local Court Flensburg  
European VAT Number: DE813211547

**Disclaimer**



©2010 cardiostrong® is a registered brand of the company SportTiedje GmbH. All rights reserved. Any use of this trademark without the explicit written permission of Sport-Tiedje is prohibited.

Product and manual are subject to change. Technical data can be changed without advance notice.

## ABOUT THIS MANUAL

Please carefully read the entire manual before installation and first use. The manual will help you to quickly set up the system and explains how to safely use it. Make sure that all persons exercising with the equipment (especially children and persons with physical, sensory, mental or motor disabilities) are informed about this manual and its contents in advance. In case of doubt, responsible persons must supervise the use of the equipment.



This equipment has been manufactured according to the latest safety knowledge. As far as possible, potential safety hazards which could cause injury have been eliminated. Make sure to carefully follow the instructions and that all parts are securely in place. If required, read through the instructions again to correct any mistakes.

Please pay close attention to the safety and maintenance instructions given here. The contract partner cannot be held liable for damage to health, accidents or damage to the equipment when it is not used in accordance with these instructions.

The following safety instructions may appear in this manual:

► **ATTENTION**

This notice indicates potentially hazardous situations which, if not avoided, may result in property damage.

⚠ **CAUTION**

This notice indicates potentially hazardous situations which, if not avoided, may result in slight or minor injuries!

⚠ **WARNING**

This notice indicates potentially hazardous situations which, if not avoided, may result in death or serious injuries!

⚠ **DANGER**

This notice indicates potentially hazardous situations which, if not avoided, will result in death or serious injuries!

ⓘ **NOTICE**

This notice indicates further useful information.

Retain these instructions in a safe place for future reference, maintenance or when ordering replacement parts.

## 1.1 Technical Data

### LCD - Display of:

- + Strokes
- + Training time
- + Distance
- + Calories
- + Heart rate
- + Watt

Resistance system: Water resistance

Training programs in total:	9
Quick Start programs/manual programs:	1
Target programs:	5 (including one heart-rate-program)
Interval programs:	3

### Weight and dimensions:

Article weight (gross, incl. packaging): Box 1/2 approx. 38 kg  
Box 2/2 approx. 5.5 kg

Article weight (net, without packaging): 34.5 kg

Packaging dimensions (L x W x H): Box1/2 approx. 105 cm x 62 cm x 58,5 cm  
Box2/2 approx. 148 cm x 13 cm x 15 cm

Set-up dimensions (L x W x H): approx. 226 cm x 55 cm x 65 cm  
Folding dimensions (L x B x H): approx. 65 cm x 55 x 226 cm

Maximum user weight: 150 kg

## 1.2 Personal Safety

### **DANGER**

- + Before you start using the equipment, you should consult your physician that this type of exercise is suitable for you from a health perspective. Particularly affected are persons who: have a hereditary disposition to high blood pressure or heart disease, are over the age of 45, smoke, have high cholesterol values, are overweight and/or have not exercised regularly in the past year. If you are under medical treatment that affects your heart rate, medical advice is absolutely essential.
- + Note that excessive training can seriously endanger your health. Please also note that heart rate monitoring systems can be inaccurate. If you notice any signs of weakness, nausea, dizziness, pain, shortness of breath, or other abnormal symptoms, stop exercising immediately and seek advice from your doctor if necessary.

### **WARNING**

- + This equipment may not be used by children under the age of 14.
- + Children should not be allowed unsupervised access to the equipment.
- + Persons with disabilities must have a medical license and must be under strict observation when using the equipment.
- + The equipment is strictly for use by one person at a time.
- + If your equipment provides a safety key, the clip of the safety key must be attached to your clothing before starting your training. In the event of a fall, the EMERGENCY STOP of the equipment can be initiated.
- + Keep your hands, feet and other body parts, hair, clothing, jewellery and other objects well clear of moving parts.
- + During use, wear suitable sports clothing rather than loose or baggy clothing. When wearing sports shoes, make sure they have suitable soles, preferably made of rubber or other non-slip materials. Shoes with heels, leather soles, studs or spikes are unsuitable. Never exercise barefoot.

### **CAUTION**

- + If your equipment needs to be connected to the power supply with a mains cable, make sure that the cable is not a potential tripping hazard.
- + Make sure that nobody is within the range of motion of the equipment during training so as not to endanger you or other persons.

### **ATTENTION**

- + Do not insert any objects of any kind into the openings of the device.



## 1.3 Electrical Safety

### **DANGER**

- + In order to reduce the risk of an electric shock, always unplug the equipment from the mains socket immediately after your workout, before assembly or dismantling, and before maintenance or cleaning. Do not pull on the cable.

### **WARNING**

- + Do not leave the equipment unattended while the mains cable is plugged into the mains socket. During your absence, the mains cable must be removed from the mains socket to prevent improper use by third parties or children.
- + If the mains cable or plug is damaged or defective, contact your contract partner. Until repair, the equipment must not be used.

### **ATTENTION**

- + The equipment requires a mains connection of 220-230 V with 50 Hz mains voltage.
- + The equipment may only be connected directly to an earthed socket using the supplied mains cable. Extension cables must conform to VDE guidelines. Always completely unwind the mains cable.
- + The socket must be protected by a fuse with a minimum fuse rating of "16 A, slow blow".
- + Do not make any changes to the mains cable or the mains plug.
- + Keep the mains cable away from water, heat, oil and sharp edges. Do not route the mains cable underneath the equipment or under a carpet or rug, and do not place any objects on top of it.

## 1.4 Set-Up Place

### WARNING

- + Do not place the equipment in main corridors or escape routes.

### CAUTION

- + Choose a location in which to place the equipment such that there is enough free space/clearance to the front, the rear and to the sides of the equipment. Make sure that you leave at least 30 cm on each side of the equipment and at least 15 cm in front of and behind the equipment as a training zone. This is the minimum required area in order to safely use the equipment. The recommended free zone around the equipment should be at least 60 cm on each side and 45 cm in front of and behind the equipment.
- + The training room should be well ventilated during training and not be exposed to any draughts.
- + Choose the place in which to set up the equipment such that there is enough free space/clearance to the front, the rear and to the sides of the equipment.
- + The set-up and mounting surface of the equipment should be flat, loadable and solid.

### ATTENTION

- + The device may only be used in one building, in sufficiently tempered and dry rooms (ambient temperatures between 10°C and 35°C). The equipment should not be used outdoors or in rooms with high humidity (over 70%) like swimming pools.
- + A floor protective mat/equipment underlay can help to protect high-quality floor coverings (parquet, laminate, cork, carpets) from dents and sweat and can help to level out slight unevenness.

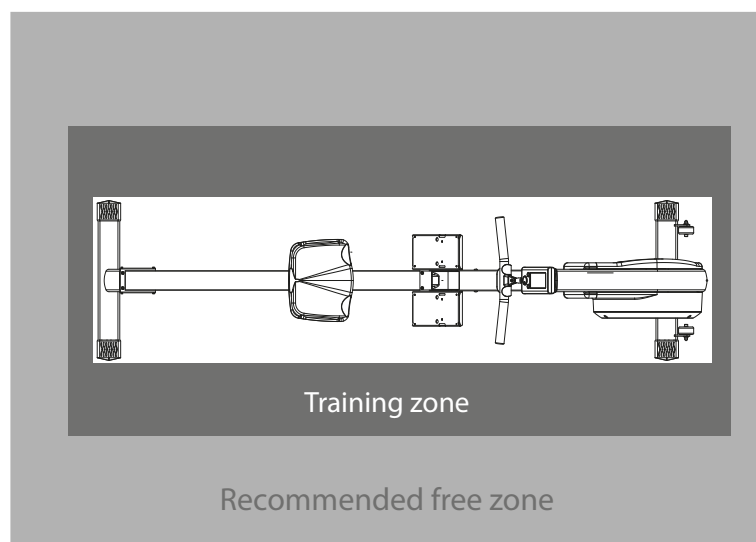

### 2.1 General Instructions



#### **DANGER**

- + Do not leave any tools, packaging materials such as foils or small parts lying around, as otherwise there is a danger of suffocation for children. Keep children away from the equipment during assembly.



#### **WARNING**

- + Pay attention to the instructions attached to the equipment in order to reduce the risk of injuries.



#### **CAUTION**

- + Ensure to have sufficient room for movement in each direction during assembly.
- + The assembly of the equipment must be carried out by at least two adults. If in doubt, seek the help of a third technically skilled person.



#### **ATTENTION**

- + To prevent damage to the equipment and the floor, assemble the equipment on a mat or packaging board.



#### **NOTICE**

- + In order to make the assembly as simple as possible, some screws and nuts to be used can already be pre-assembled.
- + Ideally, assemble the equipment at its later set-up place.

## 2.2 Scope of Delivery

The scope of delivery consist of the following parts. At the beginning, check whether all parts and tools belonging to the device are included in the scope of delivery and whether damage has occurred. In the event of complaints, the contractual partner must be contacted directly.

**⚠ CAUTION**

If parts of the scope of delivery are missing or damaged, the assembly must not be carried out.

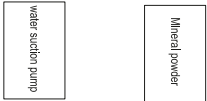
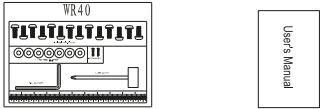
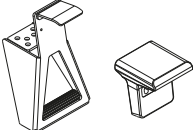
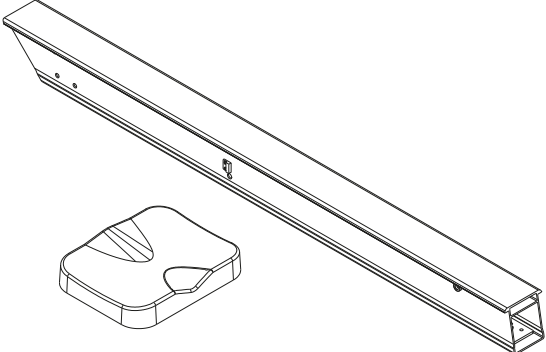
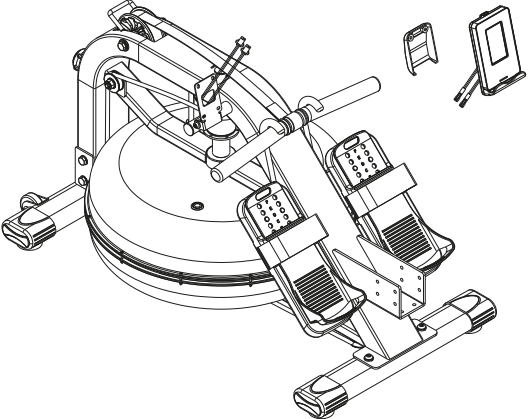
	<p>1/1</p>
	<p>1/1</p>
	<p>1/1</p>
	<p>1/1</p>
	<p>1/1/1</p>

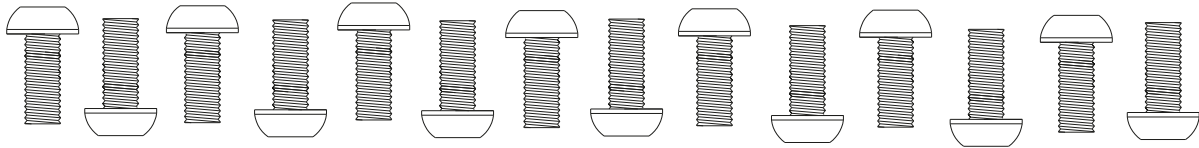

K-1 Allen Bolt M8\*P1.25\*20L(14)

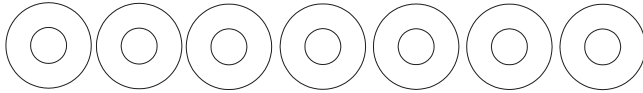

K-2 Flat washer  $\phi 8 * \phi 19 * 2T(14)$



K-3 Screw M5\*14L(2)

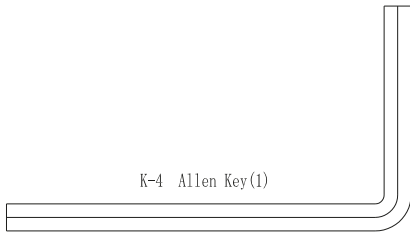

K-4 Allen Key(1)

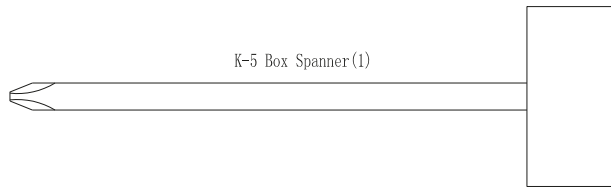

K-5 Box Spanner(1)

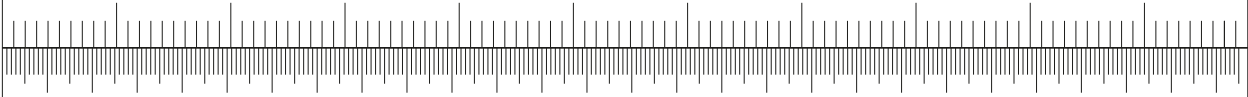

## 2.3 Assembly

Before assembly, take a close look at the individual assembly steps shown and carry out the assembly in the order given.

### ① NOTICE

First loosely screw all parts together and check that they fit properly. Tighten the screws using the tool only when you are instructed to do so.

### Step 1: Mounting the seat to the rail

1. Remove the screw (K-5) and the spacer (K-4) from the rail (H-1).
2. Slide the seat (I-11) onto the rail (H-1).
3. Mount the spacer (K-4) to the guide rail (H-1) with the screw (K-5).

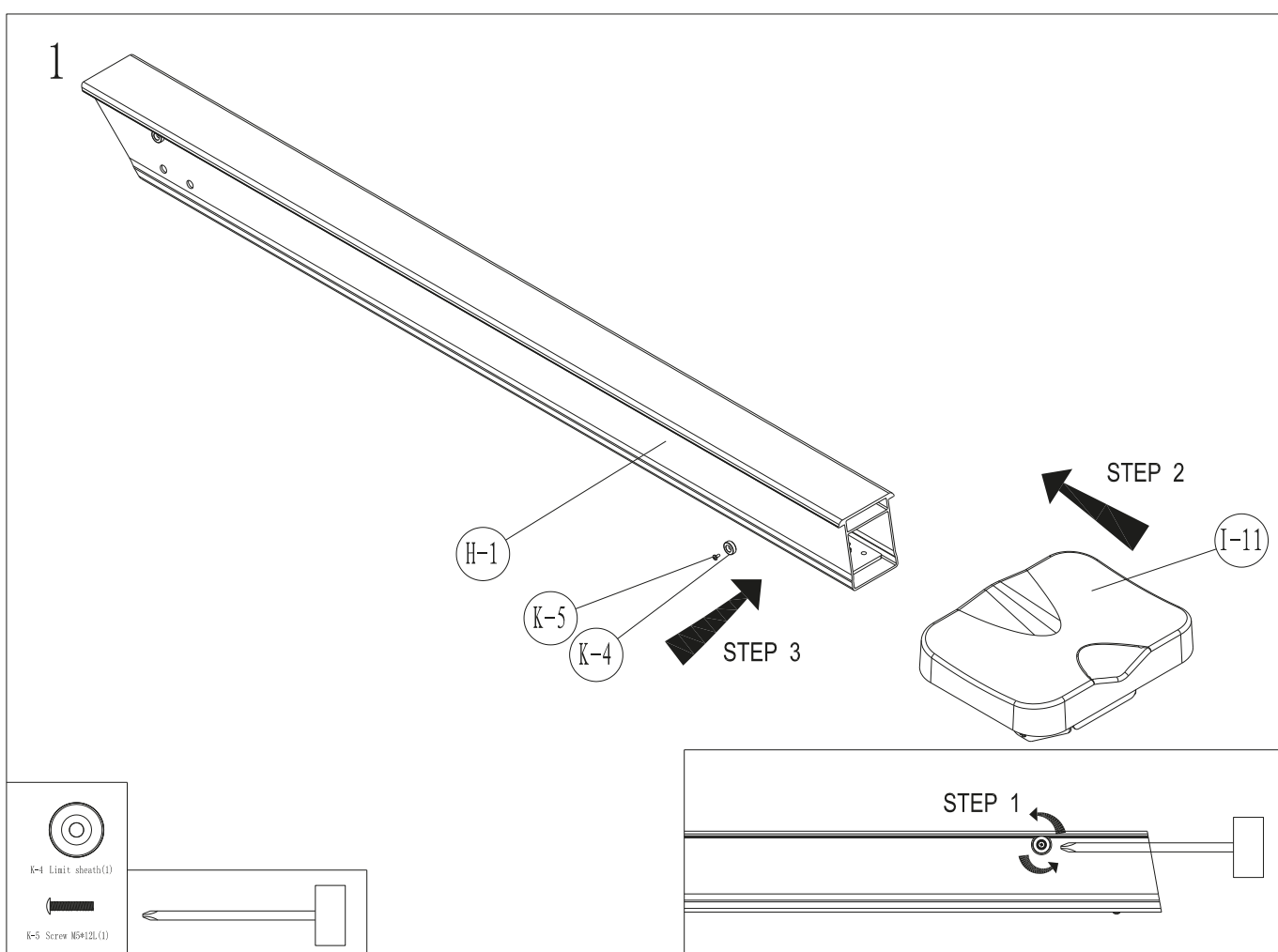

## Step 2: Mounting the frame part to the rail

1. Mount the frame part (H-6) to the frame part (J-1) with two screws (K-3).
2. Mount the frame (J-1) to the rail (H-1) with four washers (K-2) and four screws (K-1).
3. Tighten everything.

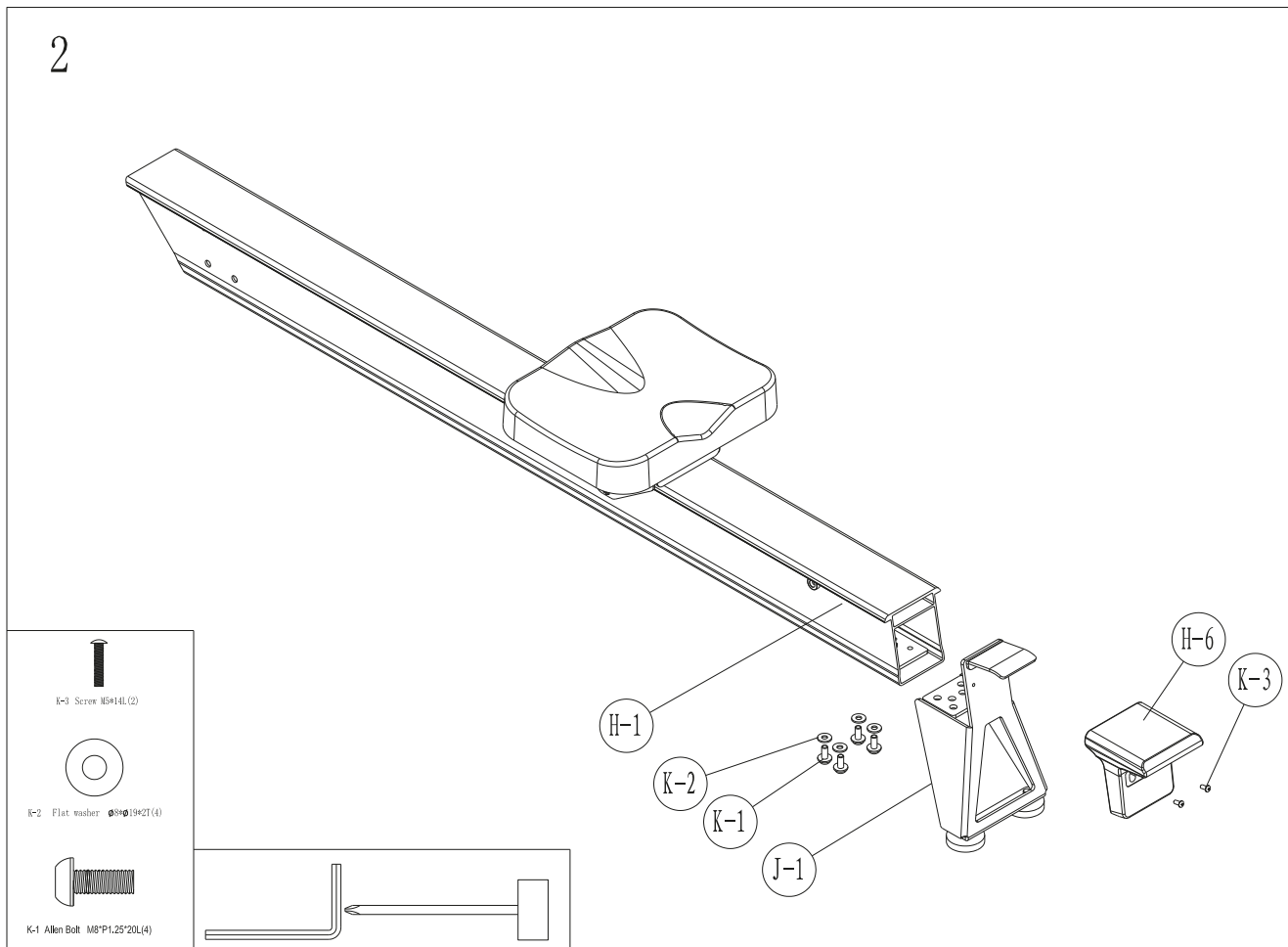

### Step 3: Mounting the console to the tank

1. Connect both cables of the tank with their respective console counter parts (A-1).
2. Place the console on the middle of the tank (B-1).

**NOTICE**

Be careful not to pinch the cables when carrying out the next step.

3. Attach the console with the console covering (B-52) using four screws (A-2).

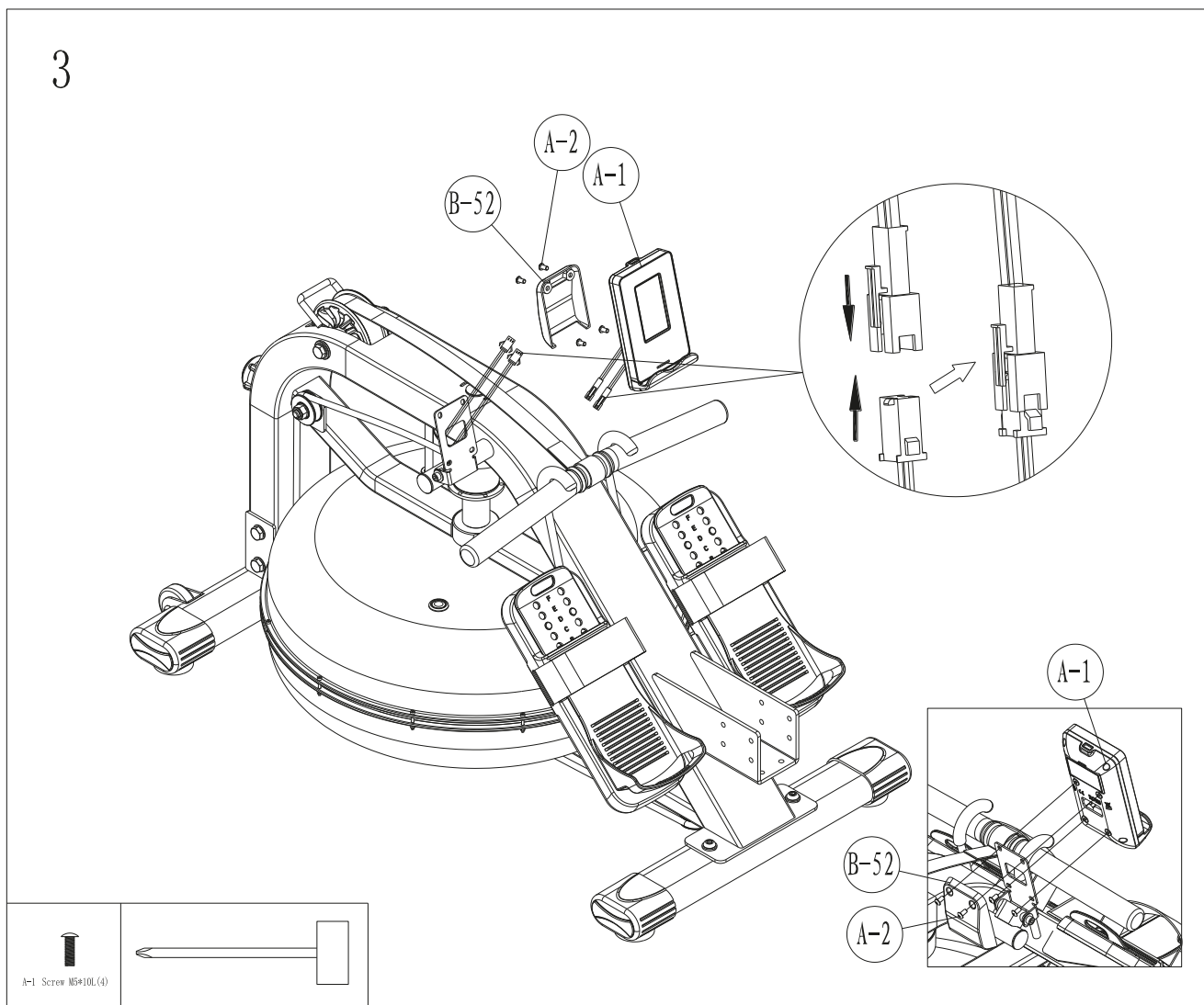



#### Step 4: Connecting the tank to the rail

1. Mount the rail (H-1) to the tank (B-1) with ten washers (K-2) and ten screws (K-1).
2. Tighten everything.

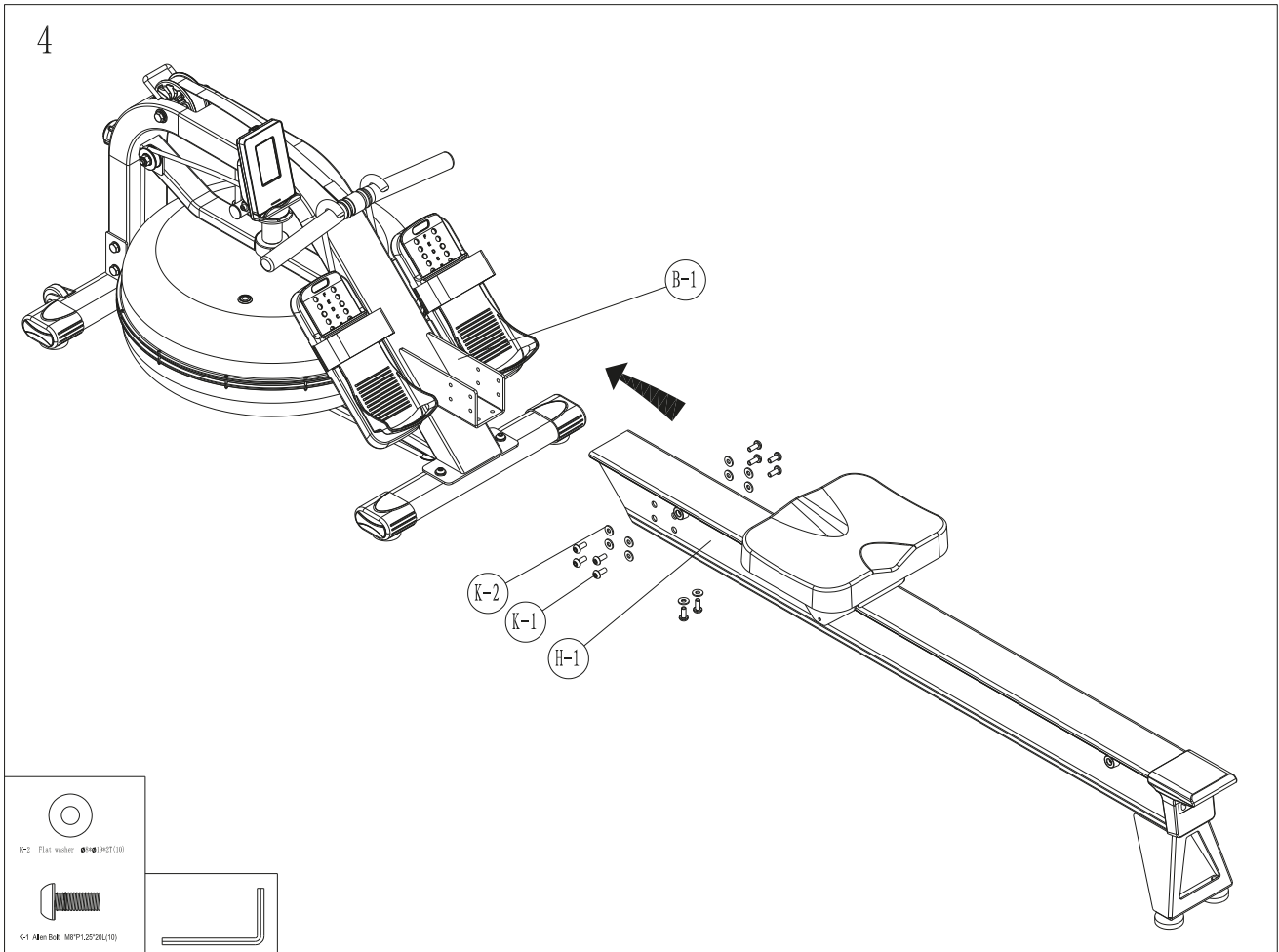

#### Step 5: Alignment of the feet

1. If the floor is uneven, you can stabilize the equipment by turning the two setting screws under the main frame.
2. Lift the equipment on the desired side and rotate the setting screws under the main frame.
3. Rotate the screws clockwise in order to remove them and to raise the equipment.
4. Rotate them counterclockwise in order to lower the equipment.

## 2.1.1 Filling and Emptying the Tank

### ⚠ CAUTION

- + The water in the tank must not be consumed and has to be disposed of after use.

### ▶ ATTENTION

- + Only fill the tank with tap water. Do not use distilled water.
  - + Do not fill the tank above its maximum capacity. This may void the warranty. The maximum filling capacity can be found in the section on the Water level in this chapter.
  - + To prevent algae formation, limescale and possible damage to the tank, we recommend the use of chlorine tablets. Only use chlorine tablets for rowing machines.
1. Remove the fill plug from the upper tank
  2. Filling the Tank: Place the funnel in the tank opening and fill the tank using the pumping siphon or a measuring cup and a bucket.
  3. Emptying the Tank: Place a bucket next to the rowing machine and pump the water with the pumping siphon from the tank into the bucket.
  4. After filling or emptying the tank, insert the fill plug into the tank and wipe off excess water from the frame.

### Water level

The water level indicator is located on the top of the tank. The minimum level for filling is predefined. The resistance is determined by the amount of water in the tank.

### ▶ ATTENTION

- The maximum capacity is 17 litres. Do not fill the tank beyond its maximum value.

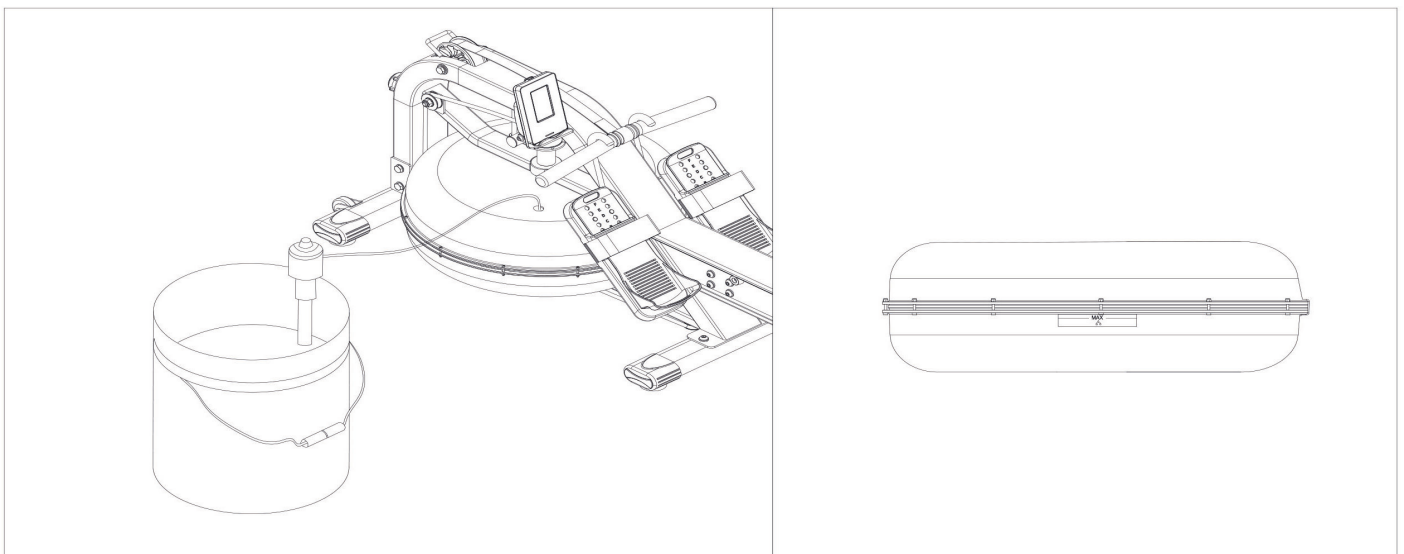

## 3 OPERATING INSTRUCTIONS

### ① NOTICE

Familiarise yourself with all the functions and setting options of the device before starting training. Have the proper use of this product explained to you by a specialist.

### 3.1 Console Display



<b>TIME</b>	+ Displays the elapsed or remaining training time (0:00–99:59)
<b>SPM</b>	+ Displays strokes per minute (0-999)
<b>DISTANCE</b>	+ Displays the distance traveled so far or the remaining distance (0-9999) + Adjustable in steps of 10
<b>WATT</b>	+ Shows the watt value (0–999)
<b>CALORIES</b>	+ Displays the total amount of burned calories or the amount calories burned so far + Adjustable in steps of 10
<b>PULSE</b>	+ Displays heart rate (30-230) + Adjustable in steps of 1
<b>STROKES</b>	+ Displays the amount of strokes that have been performed so far or the amount of strokes that still need to be performed (0–9990)

## 3.2 Button Functions

<b>SET</b>	<ul style="list-style-type: none"><li>+ Press this button to increase the desired value.</li><li>+ In stand-by mode: Press the set button and the mode button simultaneously for two seconds to switch between meters and miles.</li></ul>
<b>MODE</b>	<ul style="list-style-type: none"><li>+ Press this button to confirm your value settings or confirm the program selection.</li><li>+ Press this button during the training to pause it.</li><li>+ In standby-mode: Press the mode button and the set button simultaneously for two seconds switch between meters and miles.</li></ul>
<b>RESET</b>	<ul style="list-style-type: none"><li>+ Press this button to reset your value settings or program selection</li><li>+ Press this button to go back to the main menu.</li><li>+ Press this button for three seconds to reset all current values.</li></ul> <p><b>ⓘ NOTICE</b> "Total strokes" is the onkly value that will not be reset. The value will be reset once the device gets unplugged from the mains.</p>

## 3.3 Programs

There are a variety of programs available. These include:

- + Manual program
- + Interval programs
- + Target programs

### 3.3.1 Manual Program/Quick-Start Program

1. Simply start sculling once you are in the main menu; the quick-start program will then start automatically.
2. Choose the manual program by pressing the SET button (MANUAL) and confirm by pressing the MODE button.

*All values will start to count up.*

3. Press the mode button to pause your training.
4. Press the mode button again to continue your training.
5. Press the reset button to end your training and return to the main menu.

### 3.3.2 Interval Programs

There are a total of three interval programs available. These include:

- + 10/20
- + 20/10
- + Customized (CUSTOM)

1. Choose the category Interval programs (INTERVAL) and press the MODE button to confirm.
2. Choose an interval program (10/20, 20/10 or CUSTOM) and confirm your choice by pressing the MODE button.
3. When choosing the customized program, proceed as follows:
4. Specify your desired amount of repetitions with the SET button and confirm your choice pressing the MODE button.
5. Determine the duration of work phase with the SET button and confirm by pressing the MODE button.
6. Specify the duration of the resting phase with the SET button and confirm by pressing the MODE button.

*The program will start.*

7. In order to pause your training, press the MODE button.
8. Um mit dem Training fortzufahren, drücken Sie die Mode-Taste erneut.
9. In order to proceed with your training, press the MODE button once more.
10. To end your training and return to the main menu, press the RESET button.

### 3.3.3 Target Programs



#### **WARNING**

Your training equipment is not a medical device. The heart rate measurement of this equipment may be inaccurate. Various factors can affect the accuracy of the heart rate measurement. The heart rate measurement serves only as a training aid.



#### **NOTICE**

Measuring the heart rate is only possible with a chest strap.

There are five target programs available. These include:

- + Time
- + Distance
- + Calories
- + Strokes
- + Heart rate

1. Choose target programs (TARGET) and confirm by pressing the MODE button.
2. Choose one target program (Time, Distance, Calories, Strokes, Heart rate) and confirm by pressing the MODE button.
3. Specify the respective value with the SET button and confirm by pressing the MODE button.

*The program will start.*

*The respective value set will count downwards, the other values will count upwards*

*Once the set value is reached, the program will stop.*

4. In order to pause your training, press the MODE button.
5. To continue your training, press the MODE button a second time.
6. In order to end the training and return to the main menu, press the RESET button.

## 3.4 Notes on correct rowing

### Body moves towards the handle

#### Wrong

At the end of the movement, the body will be pulled forwards towards the handles instead the handles to the body.

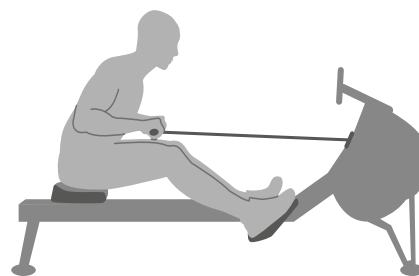

#### Right

At the end of the movement, the user slightly leans back, holds the legs down, keeps the upper body straight and pulls the handle to the body.

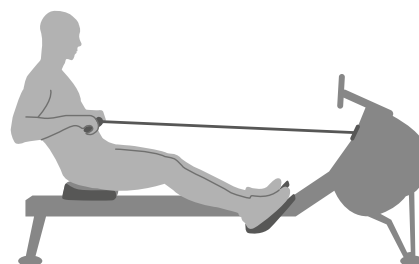

### Straddled elbows

#### Wrong

The user's elbows are straddled from the body at the end of the movement and the handle is at the height of the breast.

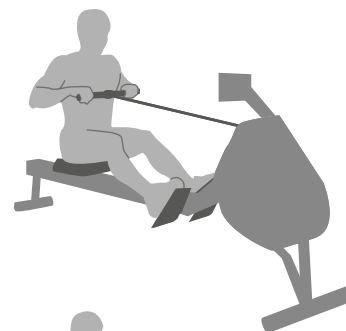

#### Right

Pull the handle to the body with straight wrists and the elbows close to the body. The elbows are brought behind the head while the handle is pulled to your waist.



### Do not completely extend

#### Wrong

At the end of the movement, the user completely stretches the leg and knee.

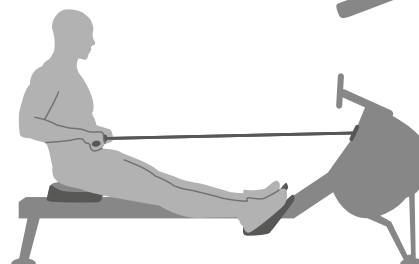

#### Right

Keep your knee slightly bent at all times even at the end of the movement instead of stretching it completely.

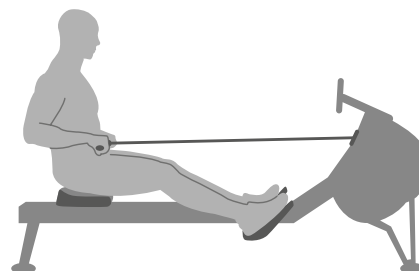

## Leaning too far forward

### Wrong

The body is bent too far forward. The shins are no longer vertical. The head and shoulders are facing the feet. The body is therefore in a weak position to execute the movement.

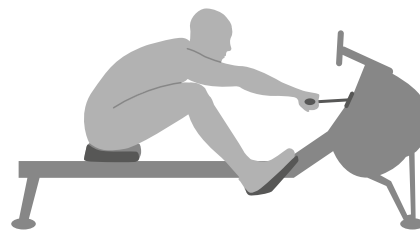

### Right

The shins are vertical. The body is pressed against the legs, the arms are completely stretched out in front and the body is slight bent forward. This position should be pleasant.

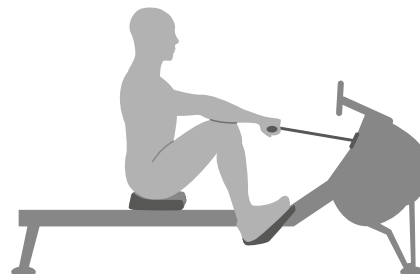

## Rowing with bent arms

### Wrong

The user begins the movement with the arms instead of first pressing with the legs.

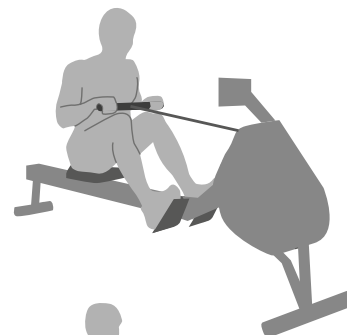

### Right

The user begins by stretching out the legs, relaxing the back and stretching the arms.



## Bent wrists

### Wrong

The user bends the wrists during the movement.

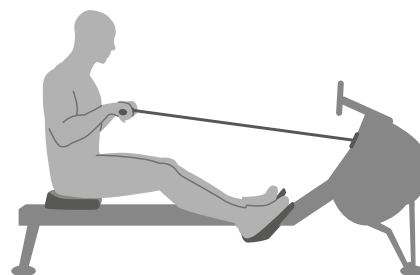

### Right

Always execute the rowing movement with straight wrists.

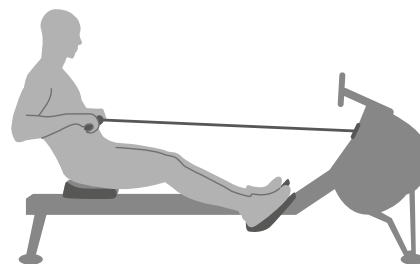



## 4.1 General Instructions

### WARNING

- + The storage location should be chosen so that improper use by third parties or children can be prevented.
- + If your equipment does not have transportation wheels, the equipment must be disassembled before transportation.

### ▶ ATTENTION

- + Make sure that the equipment is protected from moisture, dust and dirt in the selected storage location. The storage location should be dry and well ventilated and have a constant ambient temperature between 10°C and 35°C.

## 4.2 Transportation Wheels

### ▶ ATTENTION

If you want to transport your equipment over particularly sensitive and soft floor coverings, such as parquet, planks or laminate, lay out the transport route with cardboard or similar to avoid possible floor damage.

1. Stand behind the equipment and lift it until the weight is transferred to the transportation wheels. After that, you easily can move the equipment to a new position. For long transport distances the equipment should be disassembled and safely packed.
2. Select the new location by following the instructions in the section 1.4 of this manual.

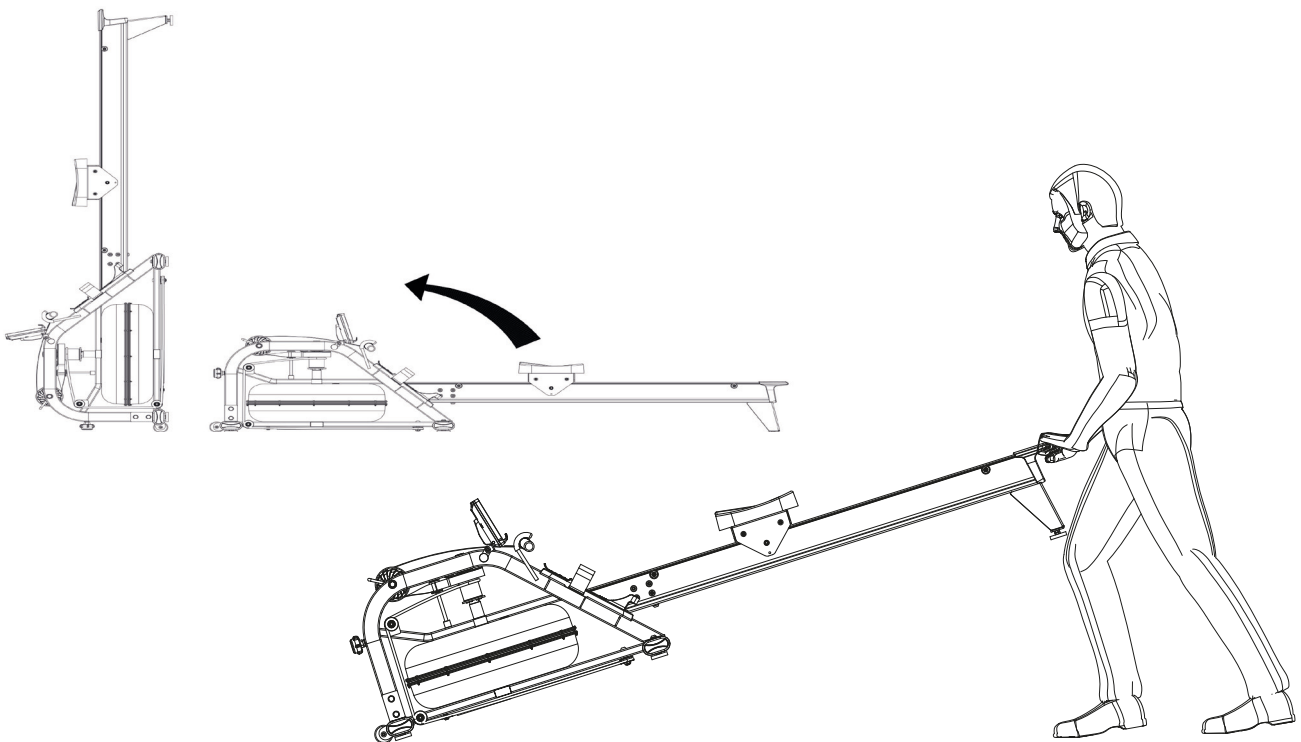

## 5.1 General Instructions



### WARNING

- + Do not make any improper changes to the equipment.



### CAUTION

- + Damaged or worn components may affect your safety and the life of the equipment. Therefore, immediately replace damaged or worn components. In such a case, contact the contract partner. The equipment must not be used until it has been repaired. If necessary, use only original spare parts.

### ATTENTION

- + In addition to the instructions and recommendations for maintenance and care given here, additional service and/or repair work may be necessary; this must only be carried out by authorised service technicians.

## 5.2 Faults and Fault Diagnosis

The equipment undergoes regular quality controls during production. Nevertheless, faults or malfunctions may occur. Frequently, individual parts are responsible for these disturbances, an exchange is usually sufficient. Please refer to the following overview for the most common errors and how to correct them. If the equipment still does not function properly, contact your contract partner.

Fault	Cause	Solution
Display is blank/is not working	Batteries empty or loose cable connection	Replace batteries or check cable connections
Creaking noises	Screw connections loosened or too tight	Check screw connections
Grinding noises on the guide rail	Guide rail or rollers dirty or guide rail dry	Clean the guide rail and then lubricate it with a suitable lubricant
No pulse display	<ul style="list-style-type: none"> <li>+ Sources of interference in the room</li> <li>+ unsuitable chest strap</li> <li>+ Wrong position of chest strap</li> <li>+ Chest strap defective or battery empty</li> <li>+ Pulse display defective</li> </ul>	<ul style="list-style-type: none"> <li>+ Eliminate sources of interference (e.g. mobile phone, WLAN, lawn mower and vacuum cleaner robot, etc. ...)</li> <li>+ Use a suitable chest strap (see RECOMMENDED ACCESSORIES).</li> <li>+ Reposition chest strap and/or moisten electrodes</li> <li>+ Changing batteries</li> </ul>

## 5.3 Maintenance and Inspection Calendar

To avoid damage from body sweat, the equipment must be cleaned with a damp towel (no solvents!) after each training session.

The following routine tasks must be performed at the specified intervals:

Part	Weekly	Monthly	Quarterly	Half-yearly
Display console	C	I		
Lubrication of slide rail and moving parts		I		
Plastic covers	C	I		
Screws and cable connections		I		
Water colour/Chlorine				I
Legend: C = clean; I = inspect				

## 6 DISPOSAL

At the end of its operational life, this equipment cannot be disposed of in normal household waste. Instead, it must be disposed of via an electricals recycling centre. Further information can be obtained from your local authority's recycling service.



The materials can be recycled as per their symbols. Through the reuse, recycling of materials or other forms of recovery of old equipment, you make an important contribution to the protection of the environment.

## 7 RECOMMENDED ACCESSORIES

To make your training experience even more efficient and pleasant, we recommend that you add suiting accessories to your fitness equipment. This could be a floor mat, for example, which makes your fitness equipment stand more securely and also protects the floor from falling sweat, but it could also be additional handrails on some treadmills or silicone spray to keep moving parts in good shape.

If you have purchased a fitness machine with pulse training and want to train your heart rate, we strongly recommend that you use a compatible chest strap, as this ensures optimum transmission of the heart rate. You may want to buy additional grips or weights for multi gyms.

Our range of accessories offers the highest quality and makes training even better. If you would like to find out more about compatible accessories, please go to the detail page of the product in our webshop (the easiest way is to enter the article number in the search field above) and go to the recommended accessories on this page. Of course, you can also contact our customer service: by telephone, e-mail, in one of our branches or via our social media channels. We will be happy to advise you!



floor mat



chest strap



chest strap contact gel



towels



silicone spray

## 8.1 Serial Number and Model Name

In order to provide you with the best possible service, please have the model name, article number, serial number, exploded drawing and parts list ready. The corresponding contact options can be found in chapter 10 of this operating manual.

**NOTICE**

The serial number of your equipment is unique. It's located on a white sticker. The exact position of this sticker is shown in the following illustration.

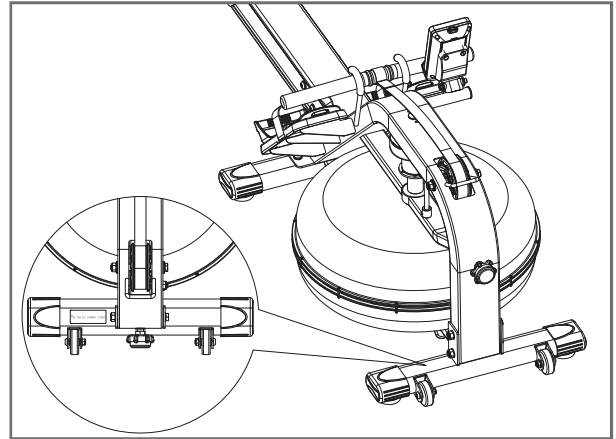

Enter the serial number in the appropriate field.

**Serial number:**

**Brand / Category:**

**Model Name:**

**Article Number:**

## 8.2 Parts List

No.	Name	Qty.
A	CONSOLE	1
A-1	SCREW	4
B	MAIN FRAME ASSEMBLY	1
B-1	MAIN FRAME(UPPER)	1
B-2	BEARING	1
B-3	RING	1
B-4	BEARING	1
B-5	RING	1
B-6	PLASTIC BUSHING	2
B-7	BIG ROLLER	1
B-8	SCREW	1
B-9	FLAT WASHER	2
B-10	NYLON NUT	1
B-11	END CAP	1
B-12	HANDLEBAR	1
B-13	GRIP	2
B-14	END CAP	1
B-15	FOAM HOOK	2
B-16	SENSOR WIRE	1
B-17	END CAP	1
B-18	MAIN FRAME	1
B-19	END CAP	1
B-20	END CAP FOR STORAGE	1
B-21	EVA FOAM	1
B-22	EVA FOAM	2
B-23	PEDAL	2
B-24	PEDAL PAD	2
B-25	PEDAL STRAP	2
B-26	EVA FOAM	2
B-27	ALLEN BOLT	8
B-28	END CAP	2

B-29	SCREW	2
B-30	FLAT WASHER	4
B-31	NYLON NUT	2
B-32	EVA FOAM	2
B-33	COVER FOR HANDLEBAR	1
B-34	BEARING	2
B-35	BUSHING	1
B-36	SCREW	2
B-37	ROLLER	2
B-38	FLAT WASHER	2
B-39	NYLON NUT	2
B-40	SCREW	2
B-41	FLAT WASHER	2
B-42	FIXING PLATE FOR SENSOR	1
B-43	SCREW	2
B-44	CLAMP FOR SENSOR	1
B-45	SENSOR WIRE	1
B-46	SCREW	1
B-47	SCREW	1
B-48	FLAT WASHER	2
B-49	END PLUG FOR CONSOLE	2
B-50	PLATE FOR CONSOLE	1
B-51	NYLON NUT	1
B-52	COVER FOR CONSOLE	1
C	SMALL WEAVING ASSEMBLY	1
C-1	ROLLER	1
C-2	BEARING	2
C-3	BUSHING	2
C-4	ALLEN BOLT	1
C-5	FLAT WASHER	1
C-6	NYLON NUT	1
D	SMALL WEAVING ASSEMBLY	1
D-1	ROLLER	1
D-2	ALLEN BOLT	1

D-3	BUSHING	1
D-4	NYLON NUT	1
D-5	FLAT WASHER	1
E	SMALL WEAVING ASSEMBLY	1
E-1	ROLLER	1
E-2	BEARING	2
E-3	BUSHING	2
E-4	ALLEN BOLT	1
E-5	FLAT WASHER	1
E-6	NYLON NUT	1
F	WEAVING ASSEMBLY	1
F-1	SLEEVE	1
F-2	WEAVING WHEEL(SMALL)	1
F-3	WEAVING FIXED AXLE	1
F-4	C-TYPE	1
F-5	SCREW	1
G	TANK ASSEMBLY	1
G-1	WATER TANK UPPER	1
G-2	WATER TANK	1
G-3	RUBBER BAND	1
G-4	TUBE	1
G-5	RUBBER PLUG	1
G-6	SCREW	12
G-7	NYLON NUT	12
G-8	FAN BLADE	1
G-9	SHAFT FOR FAN BLADE	1
G-10	FIXING SEAT FOR FAN BLADE	1
G-11	BEARING	2
G-12	FIXING SEAT	1
G-13	WASHER	1
G-14	FIXED HOOK	1
G-15	COTTER PINS	1
G-16	RUBBER BAND	1
G-17	RUBBER GASKET	1



G-18	WEAVING	1
G-19	ELASTIC ROPE	1
G-20	MAGNET	1
H	ALUMINUM RAIL ASSEMBLY	1
H-1	ALUMINUM RAIL PUNCH	1
H-2	SCREW	2
H-3	FIXING PLATE FOR ALUMINUM RAIL	1
H-4	STOPPER	2
H-5	SCREW	2
H-6	ALUMINUM RAIL COVER	1
I	SLIDER ASSEMBLY	1
I-1	SADDLE SEAPOST PAINTED	1
I-2	SADDLE WHEEL ASSEMBLY	4
I-3	SLEEVE	2
I-4	SLEEVE	4
I-5	AXLE FOR ROLLER	2
I-6	FLAT WASHER	4
I-7	NYLON NUT	4
I-8	SADDLE WHEEL ASSEMBLY	2
I-9	AXLE FOR ROLLER	2
I-10	BUSHING	2
I-11	SADDLE	1
I-12	SCREW	4
I-13	FLAT WASHER	2
I-14	NYLON NUT	2
J	REAR FOOT ASSEMBLY	1
J-1	REAR FOOT PAINTED	1
J-2	END CAP	2
K	HARDWARE KIT	1
K-1	SCREW	14
K-2	FLAT WASHER	14
K-3	SCREW	2
K-4	ALLEN KEY	1
K-5	BOX SPINNER	1

# 8.3 Exploded Drawing

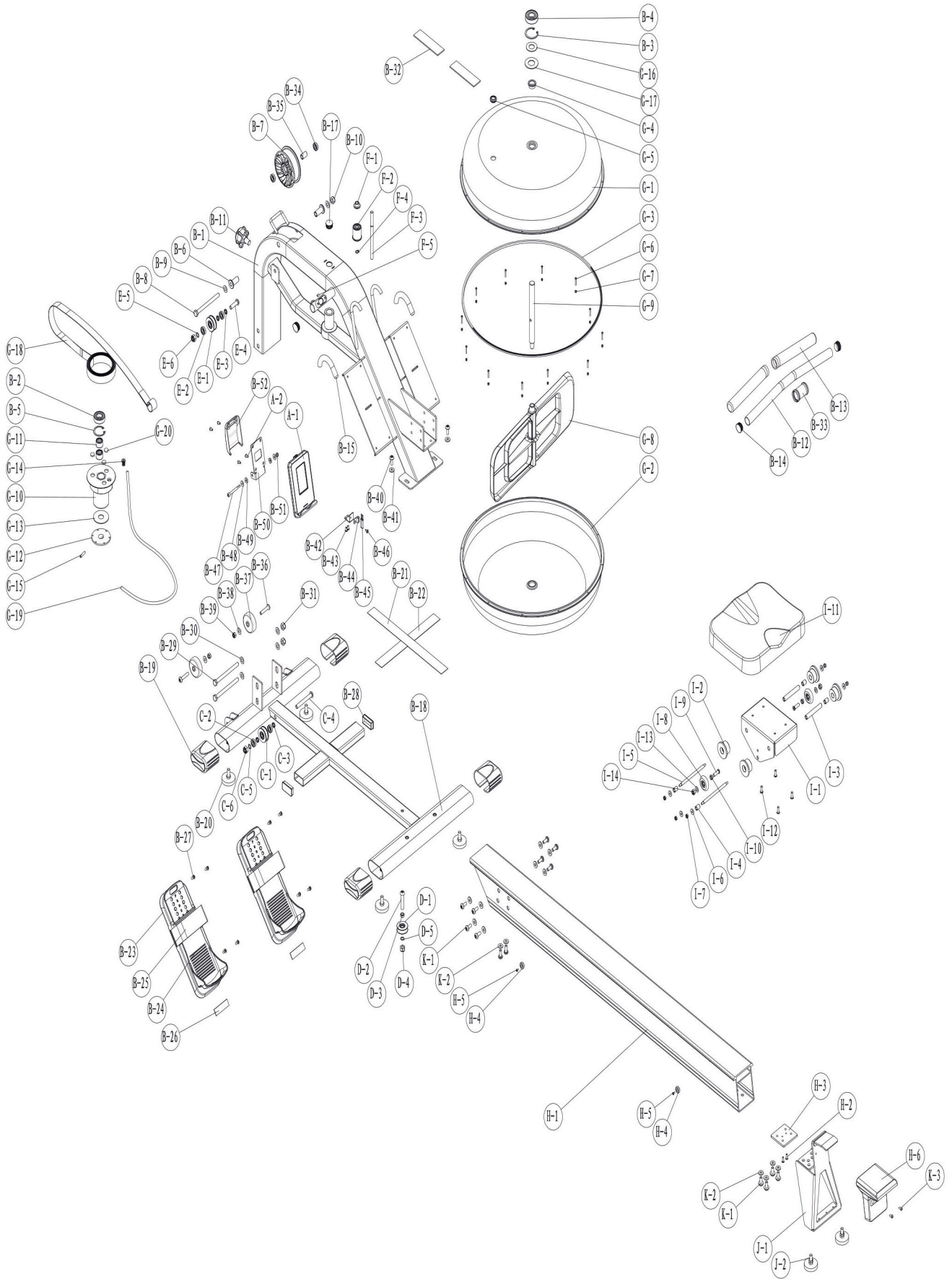

Training equipment from Taurus® is subject to strict quality control. However, if a fitness equipment purchased from us does not work perfectly, we take it very seriously and ask you to contact our customer service as indicated. We are happy to help you by phone via our service hotline.

### **Error Descriptions**

Your fitness equipment is developed for long-term, high-quality training. However, should a problem arise, please first read the operating instructions. For further assistance, please contact your contract partner or call our service hotline. To ensure your problem is solved as quickly as possible, please describe the defect as exactly as possible.

In addition to the statutory warranty, we provide a warranty for every fitness equipment purchased from us according to the following provisions.

### **Your statutory rights are not affected.**

### **Warrantee**

The warrantee is the first/original buyer and/or any person who received a newly purchased product as a gift from the original buyer.

### **Warranty period**

The warranty periods, shown on our web shop, begin on delivery of the fitness equipment. The respective warranty periods for your equipment can be found on its product website.

### **Repair Costs**

According to our choice, there will either be a repair, a replacement of individual damaged parts or a complete replacement. Spare parts, that have to be mounted while assembling the equipment, have to be replaced by the warrantee personally and are not a part of repair. After the expiration of the warranty period for repair costs, a pure parts warranty applies, which does not include the repair, installation and delivery costs.

### **The terms of use are defined as follows:**

- + Home use: solely for private use in private households up to 3 hours per day
- + Semi-professional use: up to 6 hours per day (e. g. rehabilitation centres, hotels, clubs, company gyms)
- + Professional use: more than 6 hours per day (e. g. commercial gyms)

### **Warranty Service**

Within the warranty period, equipment which develops faults as a result of material or manufacturing defects, will be repaired or replaced at our discretion. Ownership of equipment or parts of equipment which have been replaced is transferred to us. The warranty period is not extended nor does a new warranty period begin following repair or replacement under the warranty.

## Warranty Conditions

For the warranty to be valid, the following steps must be taken:

Please contact our customer service by email or phone. If the product under warranty has to be sent in for repair, the seller bears costs. After expiry of the warranty, the buyer bears the costs of transport and insurance. If the fault is covered by our warranty, you will receive a new or repaired equipment in return.

### Warranty claims are invalid in case of damage resulting from:

- + misuse or improper handling
- + environmental influences (moisture, heat, electrical surge, dust, etc.)
- + failure to follow the current safety measures for the equipment
- + failure to follow the operating instructions
- + use of force (e. g. hitting, kicking, falling)
- + interventions which were not carried out by one of our authorized service centres
- + unauthorised repair attempts

### Proof of Purchase and Serial Number

Please make sure that you are able to provide the appropriate receipt when claiming on your warranty. So that we can clearly identify the model of your equipment, and for the purposes of our quality control, you will need to give the serial number of your equipment, when contacting the service team. Where possible please have your serial number and your customer number ready when you call our service hotline. It will help us to deal with your request swiftly.

If you cannot find the serial number on your fitness equipment, our service team is at your disposal to offer further information.

### Service outside of the Warranty Period

We are also happy to issue an individual cost estimate if there is a problem with your fitness equipment after the warranty has expired, or in cases which do not fall under the terms of the warranty, e. g. normal wear and tear. Please contact our customer service team to find a quick and cost-effective solution to your problem. In such a case you will be responsible for the delivery costs.

### Communication

Many problems can be solved just by speaking to us as your specialist supplier. We know how important it is to you as a user of the fitness equipment to have problems solved quickly and simply, so you can enjoy working out with minimal interruption. For that reason, we also want to resolve your queries quickly and in a straightforward manner. Thus, please always keep your customer number and the serial number of the faulty equipment handy.

DE	DK	FR
<p><b>TECHNICAL SUPPORT</b></p> <p>☎ +49 4621 4210-900 ☎ +49 4621 4210-698 ✉ technik@sport-tiedje.de 🕒 Mo - Fr 08:00 - 18:00 Sa 09:00 - 18:00</p> <p><b>SERVICE</b></p> <p>☎ 0800 20 20277 (Freecall) ✉ info@sport-tiedje.de 🕒 Mo - Fr 08:00 - 21:00 Sa 09:00 - 21:00 So 10:00 - 18:00</p>	<p><b>TECHNICAL SUPPORT &amp; SERVICE</b></p> <p>☎ 80 90 16 50 +49 4621 4210-945 ✉ info@fitshop.dk 🕒 Mo - Fr 08:00 - 18:00 Sa 09:00 - 18:00</p>	<p><b>TECHNICAL SUPPORT &amp; SERVICE</b></p> <p>☎ +33 (0) 172 770033 +49 4621 4210-933 ✉ service-france@fitshop.fr 🕒 Mo - Fr 08:00 - 18:00 Sa 09:00 - 18:00</p>
	PL	BE
	<p><b>TECHNICAL SUPPORT &amp; SERVICE</b></p> <p>☎ 22 307 43 21 +49 4621 42 10-948 ✉ info@fitshop.pl 🕒 Mo - Fr 08:00 - 18:00 Sa 09:00 - 18:00</p>	<p><b>TECHNICAL SUPPORT &amp; SERVICE</b></p> <p>☎ 02 732 46 77 +49 4621 42 10-932 ✉ info@fitshop.be 🕒 Mo - Fr 08:00 - 18:00 Sa 09:00 - 18:00</p>

UK	NL	INT
<p><b>TECHNICAL SUPPORT</b></p> <p>☎ +44 141 876 3986 ✉ support@powerhousefitness.co.uk</p> <p><b>SERVICE</b></p> <p>☎ +44 141 876 3972 🕒 Mo - Fr 9am - 5pm</p>	<p><b>TECHNICAL SUPPORT &amp; SERVICE</b></p> <p>☎ +31 172 619961 ✉ info@fitshop.nl 🕒 Ma - Do 09:00 - 17:00 Vr 09:00 - 21:00 Za 10:00 - 17:00</p>	<p><b>TECHNICAL SUPPORT &amp; SERVICE</b></p> <p>☎ +49 4621 4210-944 ✉ service-int@sport-tiedje.de 🕒 Mo - Fr 8am - 6pm Sat 9am - 6pm</p>
	AT	CH
	<p><b>TECHNICAL SUPPORT &amp; SERVICE</b></p> <p>☎ 0800 20 20277 (Freecall) +49 4621 42 10-0 ✉ info@sport-tiedje.at 🕒 Mo - Fr 08:00 - 18:00 Sa 09:00 - 18:00</p>	<p><b>TECHNICAL SUPPORT &amp; SERVICE</b></p> <p>☎ 0800 202 027 +49 4621 42 10-0 ✉ info@sport-tiedje.ch 🕒 Mo - Fr 08:00 - 18:00 Sa 09:00 - 18:00</p>

Please find a detailed overview including address and opening hours for all stores of the Sport-Tiedje Group in Germany and abroad on the following website:

[www.sport-tiedje.com/en/stores](http://www.sport-tiedje.com/en/stores)

# WE LIVE FITNESS

## WEBSHOP AND SOCIAL MEDIA

Sport-Tiedje is Europe's largest specialist store for home fitness equipment with currently over 70 stores and one of the world's most renowned online mail order companies for fitness equipment. Private customers order via the 25 web shops in the respective national language or have their desired equipment assembled on site. In addition, the company supplies fitness studios, hotels, sports clubs, companies and physio practices with professional equipment for endurance and strength training.

Sport-Tiedje offers a wide range of fitness equipment from renowned manufacturers, high-quality in-house developments and comprehensive services, such as a build-up service and sports scientific advice before and after the purchase. The company employs numerous sports scientists, fitness trainers and competitive athletes.

Visit us also on our social media platforms or our blog!

