



Assembly and Operating Instructions



max. 130 kg



~ 60 Min.



56 kg

L 150 | W 67 | H 155

FSTEX20B.01.01

Art. No. CST-EX20-B

Crosstrainer **EX20**

Content

1	GENERAL INFORMATION	8
1.1	Technical Data	8
1.2	Personal Safety	9
1.3	Electrical Safety	10
1.4	Set-Up Place	11
2	ASSEMBLY	12
2.1	General Instructions	12
2.2	Scope of Delivery	12
2.3	Assembly	13
3	OPERATING INSTRUCTIONS	21
3.1	Console Display	21
3.2	Button Functions	23
3.3	Selecting and Setting the User Account	24
3.4	Programmes	25
3.4.1	Manual Programme	25
3.4.2	Training Programme	26
3.4.3	User-defined Programme	27
3.4.4	Heart Rate Oriented Programmes	27
3.4.5	Watt-controlled Programme	28
3.4.6	Body Fat Programme	28
3.5	Heart-rate Measuring	31
4	STORAGE AND TRANSPORT	33
4.1	General Instructions	33
4.2	Transportation Wheels	33
5	TROUBLESHOOTING, CARE AND MAINTENANCE	34
5.1	General Instructions	34
5.2	Faults and Fault Diagnosis	34
5.3	Error Codes and Troubleshooting	35
5.4	Maintenance and Inspection Calendar	36
6	DISPOSAL	36
7	RECOMMENDED ACCESSORIES	37

8	ORDERING SPARE PARTS	38
8.1	Serial Number and Model Name	38
8.2	Parts List	39
8.3	Exploded Drawing	41
9	WARRANTY	42
10	CONTACT	44

Dear customer,

thank you for choosing fitness equipment from cardiostrong®. Cardiostrong offers high-quality home fitness equipment that is optimally adapted to the conditions at home. Train at home no matter what the weather or time of the day. Cardiostrong fitness equipment offers training programmes and a variety of equipment for all training levels and all training goals. Further information can be found at www.fitshop.com or www.cardiostrong.de. We hope you enjoy your training!

Further information can be found at www.fitshop.com.

Intended Use

The equipment may only be used for its intended purpose.

The equipment is only suitable for home use. The equipment is not suitable for semi-professional (e.g. hospitals, associations, hotels, schools, etc.) and commercial or professional use (e.g. fitness studios).

Legal Notice

Fitshop GmbH
Europe's No. 1 for home fitness

International Headquarters
Flensburger Straße 55
24837 Schleswig
Germany

Management:
Christian Grau
Sebastian Campmann
Dr. Bernhard Schenkel
No. HRB 1000 SL
Local Court Flensburg
European VAT Number: DE813211547

Disclaimer

© cardiostrong is a registered brand of the company Fitshop GmbH. All rights reserved. Any use of this trademark without the explicit written permission of Fitshop is prohibited.

Product and manual are subject to change. Technical data can be changed without advance notice.

FITSHOP

Europe's No.1 for Home Fitness

ABOUT THIS MANUAL

Please carefully read the entire manual before installation and first use. The manual will help you to quickly set up the system and explains how to safely use it. Make sure that all persons exercising with the equipment (especially children and persons with physical, sensory, mental or motor disabilities) are informed about this manual and its contents in advance. In case of doubt, responsible persons must supervise the use of the equipment.

Due to ongoing changes and software optimisations, the manual may have to be updated. If you notice any discrepancies during assembly or use, please refer to the manual uploaded to the webshop. The latest manual is always available there.



This equipment has been manufactured according to the latest safety knowledge. As far as possible, potential safety hazards which could cause injury have been eliminated. Make sure to carefully follow the instructions and that all parts are securely in place. If required, read through the instructions again to correct any mistakes.

Training devices must be classified according to accuracy and use. Accuracy classes are only applicable to devices that display training data.

Accuracy classes

Class A: high accuracy.

Class B: medium accuracy.

Class C: low accuracy.

The use classes explain the intended use of the training device.

Use classes

Class S (studio): professional and/or commercial use.

These training devices are intended for the use in training rooms of facilities such as sports clubs, school facilities, hotels, clubs and studios whose access and supervision is specifically regulated by the owner (person with legal responsibility).

Class H (home use): use at home.

These stationary training devices are intended for the use in private homes where access to the training device is regulated by the owner (person with legal responsibility).

Please pay close attention to the safety and maintenance instructions given here. The contract partner cannot be held liable for damage to health, accidents or damage to the equipment when it is not used in accordance with these instructions.

The following safety instructions may appear in this manual:

► **ATTENTION**

This notice indicates potentially hazardous situations which, if not avoided, may result in property damage.

⚠ **CAUTION**

This notice indicates potentially hazardous situations which, if not avoided, may result in slight or minor injuries!

⚠ **WARNING**

This notice indicates potentially hazardous situations which, if not avoided, may result in death or serious injuries!

⚠ **DANGER**

This notice indicates potentially hazardous situations which, if not avoided, will result in death or serious injuries!

ⓘ **NOTICE**

This notice indicates further useful information.

Retain these instructions in a safe place for future reference, maintenance or when ordering replacement parts.

1.1 Technical Data

LCD display

- + Speed in km/h /cadence (rotations per minute)
- + training time in min
- + training distance in km
- + calories burnt in kcal
- + heart rate (when using the hand sensors or a chest strap)
- + Watts/Resistance level

Resistance system:	electronic magnetic brake system
Resistance level:	16
Watt:	10 - 350 Watt (adjustable in 5 Watt increments)
Total number of training programmes:	19
Manual programme:	1
Preset programmes:	12
Watt-controlled programme:	1
Heart rate controlled programmes:	4
User defined programme:	1
Balance mass:	24 kg
Transmission ratio:	1 : 8.82
Stride length:	38 cm
Stride width:	18 cm
Stride height:	23 cm
Adjustable pedal position:	3
Length setting of pedal arms:	4
Weight and dimensions:	
Article weight (gross, including packaging):	62 kg
Article weight (net, without packaging):	56 kg
Packaging dimensions (L x W x H):	approx. 132 cm x 38 cm x 65 cm
Setup dimensions (L x W x H):	approx. 150 cm x 67 cm x 155 cm
Maximum user weight:	130 kg/286 lbs
Use class:	H

1.2 Personal Safety

DANGER

- + Before you start using the equipment, you should consult your physician that this type of exercise is suitable for you from a health perspective. Particularly affected are persons who: have a hereditary disposition to high blood pressure or heart disease, are over the age of 45, smoke, have high cholesterol values, are overweight and/or have not exercised regularly in the past year. If you are under medical treatment that affects your heart rate, medical advice is absolutely essential.
- + Note that excessive training can seriously endanger your health. Please also note that heart rate monitoring systems can be inaccurate. If you notice any signs of weakness, nausea, dizziness, pain, shortness of breath, or other abnormal symptoms, stop exercising immediately and seek advice from your doctor if necessary.
- + The owner must communicate all warnings and instructions to the user.

WARNING

- + This equipment may not be used by children under the age of 14.
- + Children should not be allowed unsupervised access to the equipment.
- + Persons with disabilities must have a medical license and must be under strict observation when using the equipment.
- + Remember that your device does not have a freewheel function. Therefore moving parts cannot be stopped immediately.
- + Note that the individual physical power required to perform an exercise may differ from the displayed mechanical power.
- + When ascending and descending, make sure that one of the treads is in the lowest position.
- + The equipment is strictly for use by one person at a time.
- + Keep your hands, feet and other body parts, hair, clothing, jewellery and other objects well clear of moving parts.
- + During use, wear suitable sports clothing rather than loose or baggy clothing. When wearing sports shoes, make sure they have suitable soles, preferably made of rubber or other non-slip materials. Shoes with heels, leather soles, studs or spikes are unsuitable. Never exercise barefoot.

CAUTION

- + If your equipment needs to be connected to the power supply with a mains cable, make sure that the cable is not a potential tripping hazard.
- + Make sure that nobody is within the range of motion of the equipment during training so as not to endanger you or other persons.
- + Do not insert any objects of any kind into the openings of the device.
- + Be aware that if adjustment devices are left protruding, they may impede the user's movement.

1.3 Electrical Safety

DANGER

- + In order to reduce the risk of an electric shock, always unplug the equipment from the mains socket immediately after your workout, before assembly or dismantling, and before maintenance or cleaning. Do not pull on the cable.

WARNING

- + Do not leave the equipment unattended while the mains cable is plugged into the mains socket. During your absence, the mains cable must be removed from the mains socket to prevent improper use by third parties or children.
- + If the mains cable or plug is damaged or defective, contact your contract partner. Until repair, the equipment must not be used.

ATTENTION

- + The equipment requires a mains connection of 220-230 V with 50 Hz mains voltage.
- + The equipment may only be connected directly to an earthed socket using the supplied mains cable. Extension cables must conform to VDE guidelines. Always completely unwind the mains cable.
- + The socket must be protected by a fuse with a minimum fuse rating of "16 A, slow blow".
- + Do not make any changes to the mains cable or the mains plug.
- + Keep the mains cable away from water, heat, oil and sharp edges. Do not route the mains cable underneath the equipment or under a carpet or rug, and do not place any objects on top of it.
- + If your purchased item is equipped with a TFT console, software updates must be carried out regularly. Follow the instructions on the console to perform the update(s).
- + The software systems on gym equipment with TFT consoles are set up only for the pre-installed apps. Do not install any additional apps.

NOTICE

- + The pre-installed apps on TFT consoles are produced and provided by external manufacturers. Fitshop does not take any responsibility for the availability, functionality or contents of these apps.

1.4 Set-Up Place

WARNING

- + Do not place the equipment in main corridors or escape routes.

CAUTION

- + Choose a location in which to place the equipment such that there is enough free space/clearance to the front, the rear and to the sides of the equipment.
- + The training room should be well ventilated during training and not be exposed to any draughts.
- + Choose the place in which to set up the equipment such that there is enough free space/clearance to the front, the rear and to the sides of the equipment.
- + The free area in the direction from which the exercise equipment is accessed must be at least 0.6 m larger than the exercise area.
- + The set-up and mounting surface of the equipment should be flat, loadable and solid.

ATTENTION

- + The device may only be used in one building, in sufficiently tempered and dry rooms (ambient temperatures between 10°C and 35°C). The equipment should not be used outdoors or in rooms with high humidity (over 70%) like swimming pools.
- + A floor protective mat/equipment underlay can help to protect high-quality floor coverings (parquet, laminate, cork, carpets) from dents and sweat and can help to level out slight unevenness.
- + For Class S equipment, the exercise equipment may only be used in areas where access, supervision and control are specifically regulated by the owner.

2.1 General Instructions



DANGER

- + Do not leave any tools, packaging materials such as foils or small parts lying around, as otherwise there is a danger of suffocation for children. Keep children away from the equipment during assembly.



WARNING

- + Pay attention to the instructions attached to the equipment in order to reduce the risk of injuries.



CAUTION

- + Ensure to have sufficient room for movement in each direction during assembly.
- + The assembly of the equipment must be carried out by at least two adults. If in doubt, seek the help of a third technically skilled person.



ATTENTION

- + To prevent damage to the equipment and the floor, assemble the equipment on a mat or packaging board.



NOTICE

- + In order to make the assembly as simple as possible, some screws and nuts to be used can already be pre-assembled.
- + Ideally, assemble the equipment at its later set-up place.

2.2 Scope of Delivery

The scope of delivery consist of the following parts. At the beginning, check whether all parts and tools belonging to the device are included in the scope of delivery and whether damage has occurred. In the event of complaints, the contractual partner must be contacted directly.



CAUTION

- If parts of the scope of delivery are missing or damaged, the assembly must not be carried out.

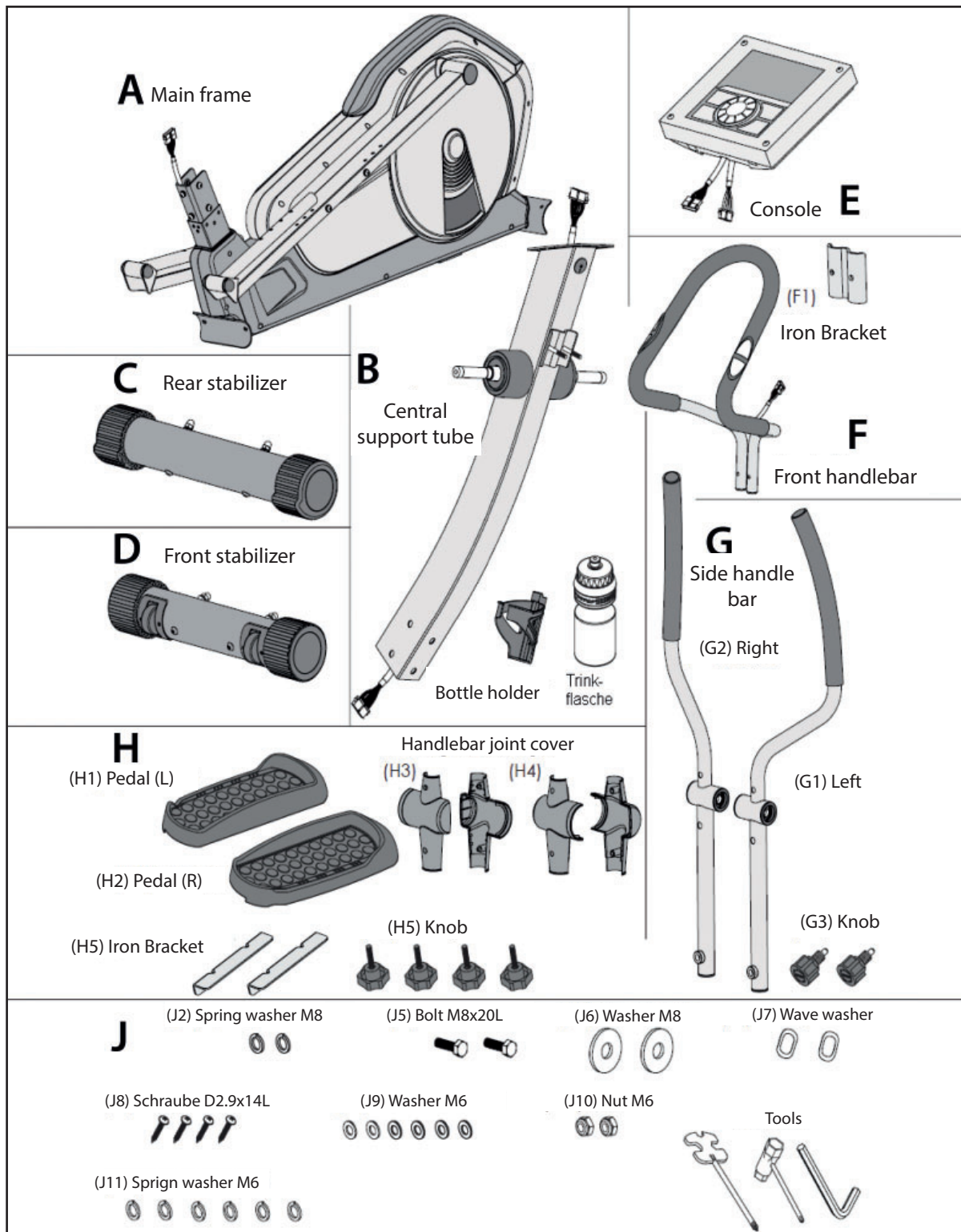

2.3 Assembly

Before assembly, take a close look at the individual assembly steps shown and carry out the assembly in the order given.

ⓘ NOTICE

- + First loosely screw all parts together and check that they fit properly. Tighten the screws using the tool only when you are instructed to do so.

- + If you have difficulty recognising the graphics, we recommend that you open and/or download the PDF instructions stored in the webshop on your end device (e.g. smartphone, tablet or PC). There you have the option of zooming in closer. Please note that the Adobe Acrobat Reader programme must be installed on your end device in order to open the file.

Step 1: Assembly of the Rear Stabilizer

1. Remove the washers (J1), spring washers (J2) and nuts (J3) from the rear stabilizer (C).
2. Mount the rear stabilizer (C) to the main frame (A) with the preinstalled screws and previously removed washers (J1), spring washers (J2) and nuts (J3).

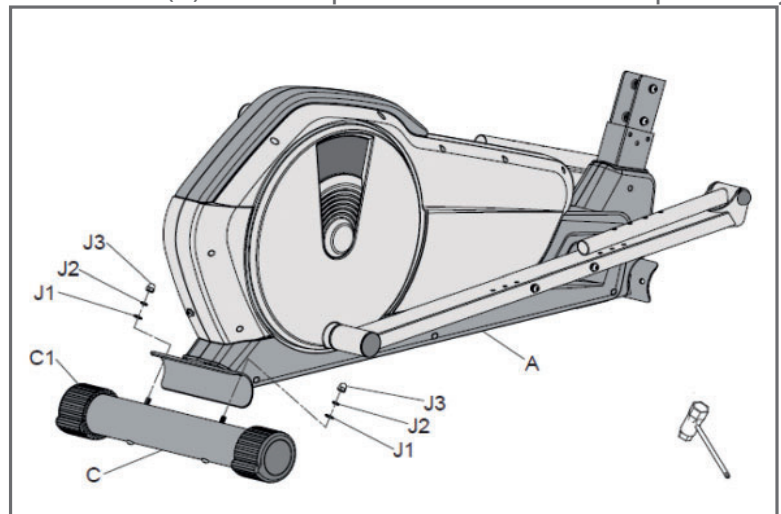

Step 2: Assembly of the Central Support Tube

1. Remove the screws (J4), spring washers (J2) and washers (J1) from the main frame (A).
2. Connect the sensor cables A1 and B1.

► **ATTENTION**

Make sure not to pinch the cables.

3. Mount the central support tube (B) to the main frame (A) with the previously removed screws (J4), spring washers (J2) and washers (J1).

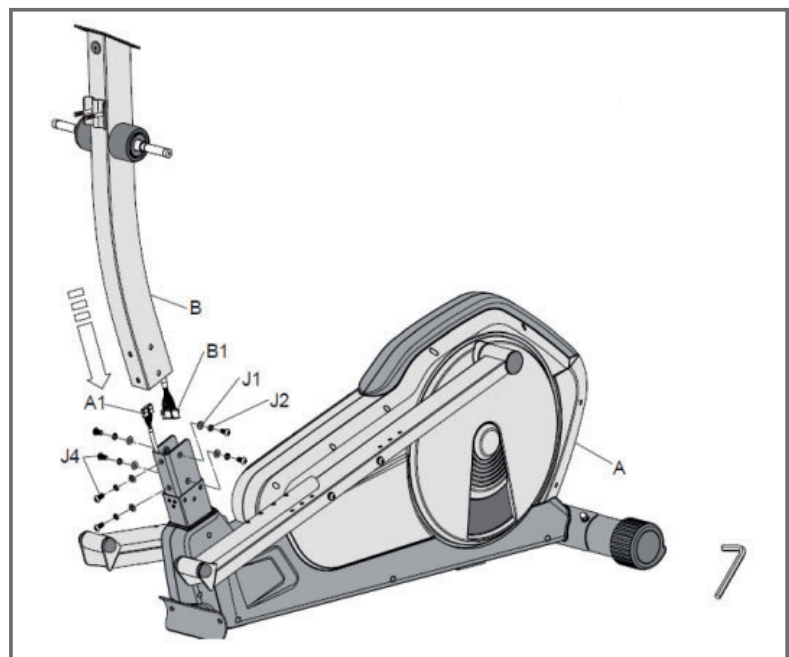

Step 3: Assembly of the Side Handlebars

1. Slide two wave washers (J7) onto the axle of the central support tube (B).
2. Mount the left side handlebar (G1) to the axle with one screw (J5), one spring washer (J2) and one washer (J6).
3. Repeat the step for the right side handlebar (G2).

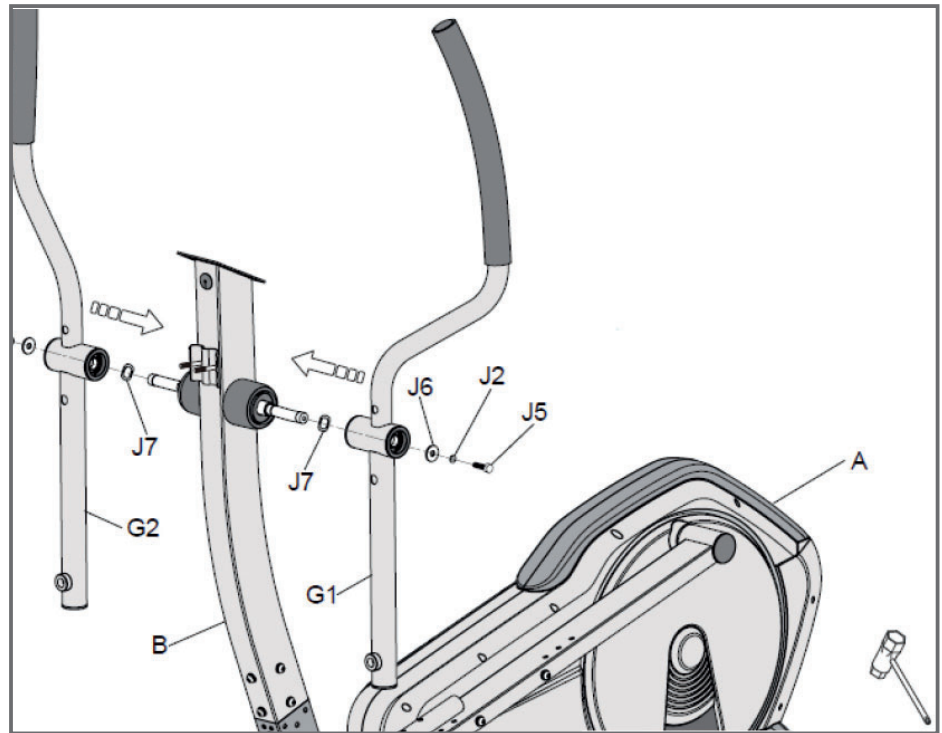

Step 4: Assembly of the Pedal Tubes

1. Remove the preinstalled screws (J4), spring washers (J2) and washers (J1).
2. Attach the iron bracket (H5) to the pedal tube with the previously removed screws (J4), spring washers (J2) and washers (J1).
3. Repeat the steps for the other pedal bar.
4. Mount the lower end of the side handlebars (G1 & G2) to the pedal tubes with one knob (G3) each.

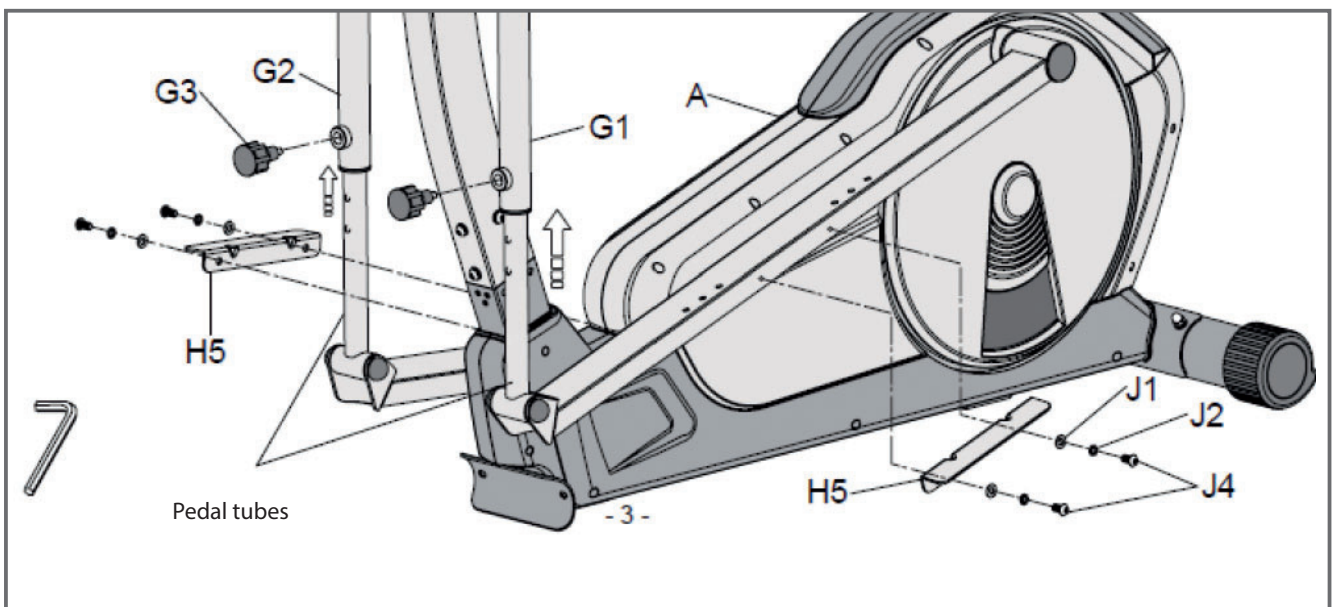

Step 5: Assembly of the Front Stabilizer

1. Remove the washers (J1), spring washers (J2) and nuts (J3) from the front stabilizer (D).
2. Mount the front stabilizer (D) to the main frame (A) with the preinstalled screws and previously removed washers (J1), spring washers (J2) and nuts (J3).

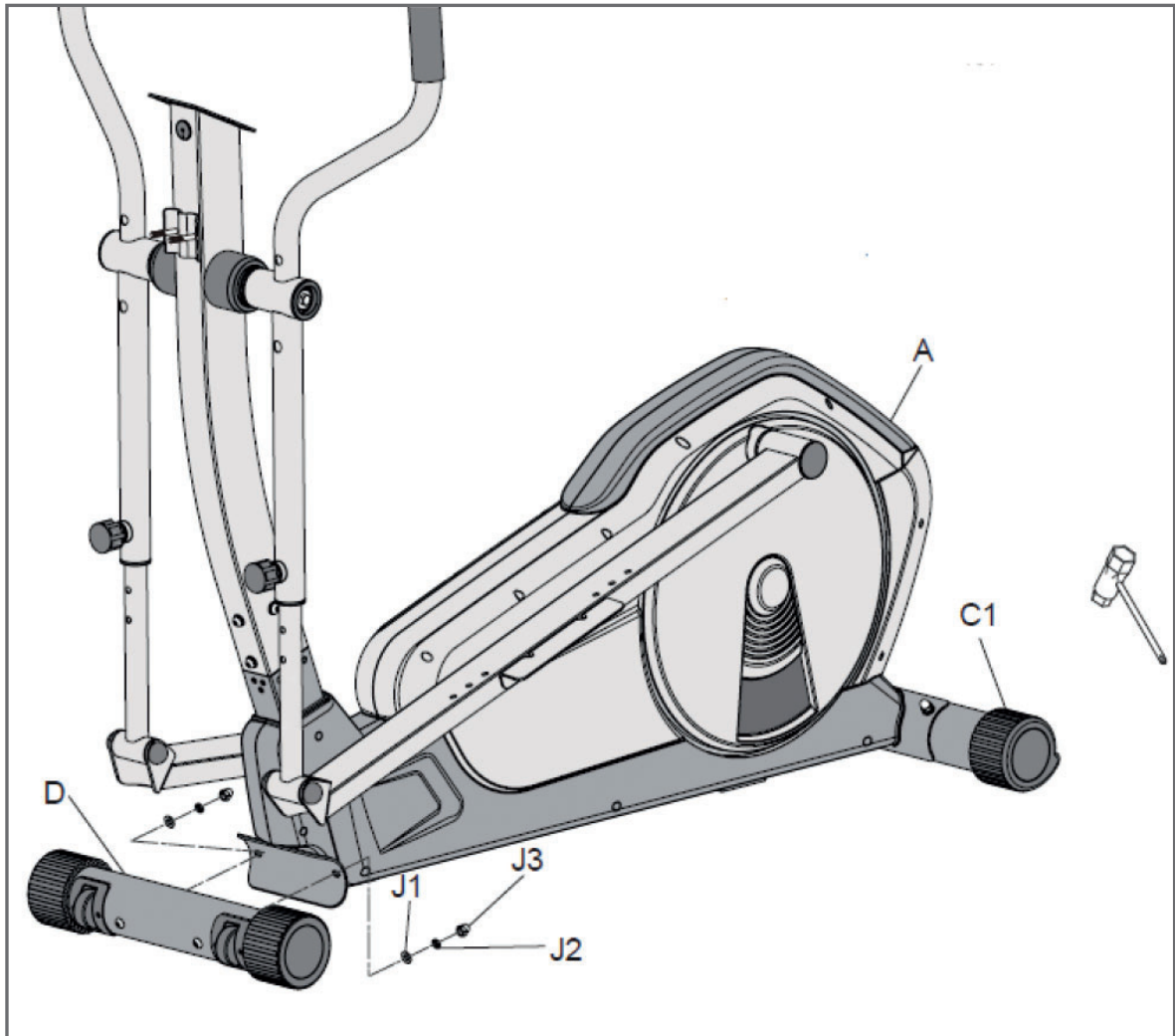

Step 6: Assembly of the Pedals

ⓘ NOTICE

There are three different position settings for the pedals.

1. Mount the right pedal (H2) with two knobs (H6), two spring washers (J11) and two washers (J9).
2. Repeat the step with the left pedal (H1).

▶ ATTENTION

Make sure to to tighten the knobs (H6).

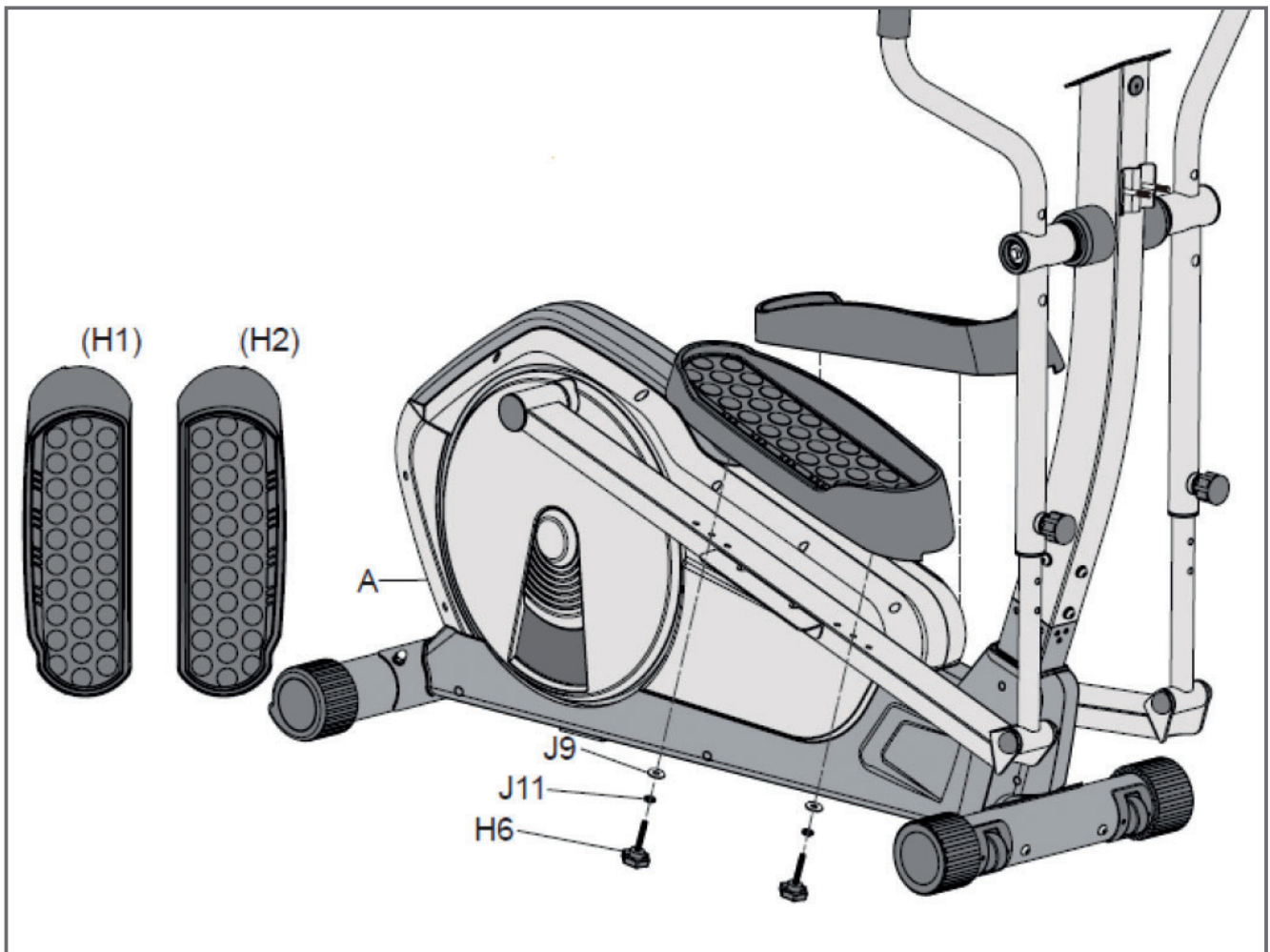

Step 7: Assembly of the Front Handlebar

1. Mount the front handlebar (F) to the central support tube (B) with the iron bracket (F1), two washers (J9), two spring washers (J11) and two nuts (J10).
2. Pull the hand pulse cable (B2) through the opening of the central support tube (B).
3. Mount two handlebar joint covers (H3 & H4) to the left side handlebar (G1) with four screws (J8).
4. Repeat step three with the right side handlebar (G2).

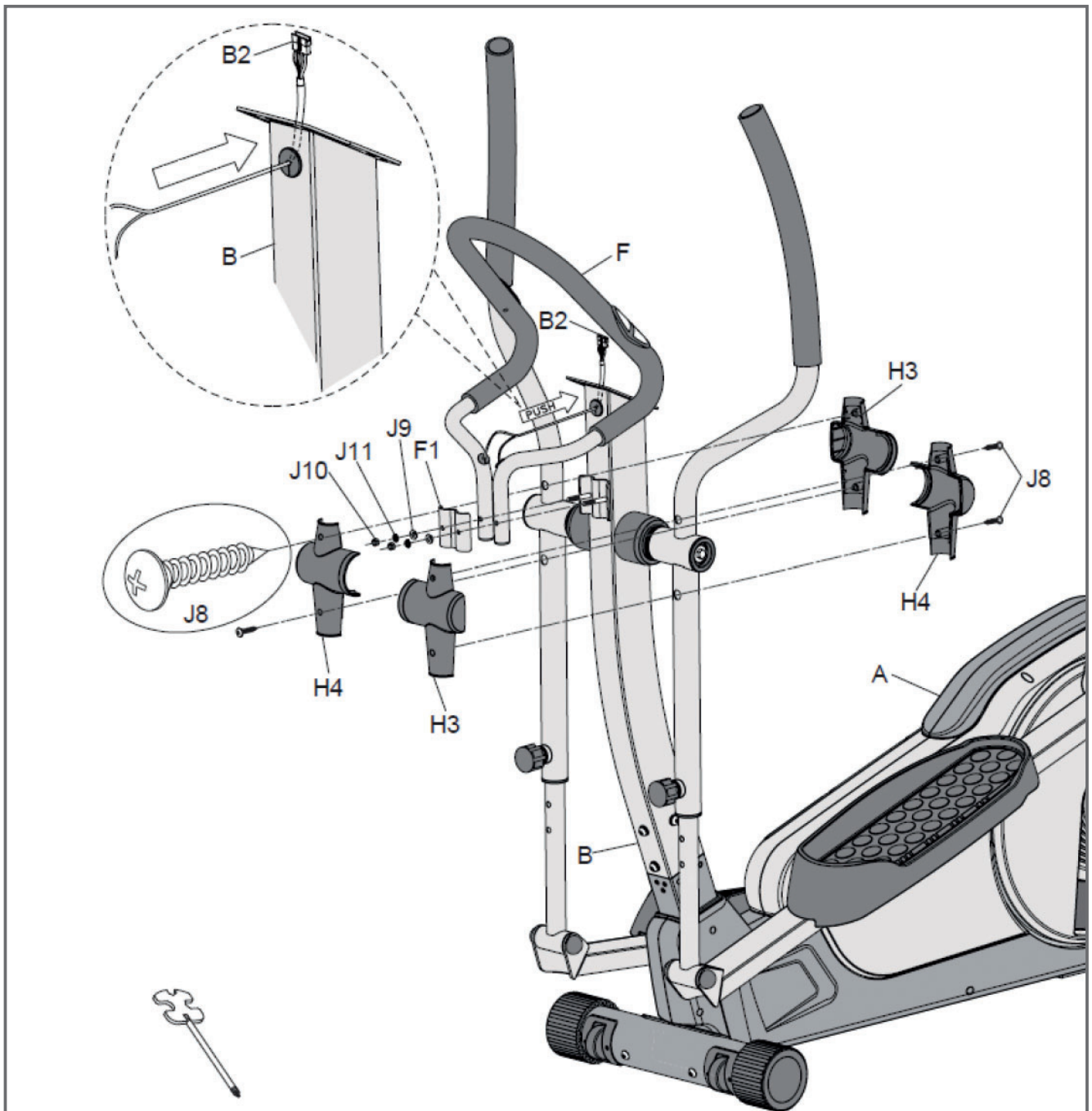

Step 8: Assembly of the Console and Bottle Holder

1. Connect the sensor cables (B1 & B2) with the cables of the console and slide the console (E) onto the designated plate.
2. Loosen the preinstalled screws (J12) on the central support tube (B).
3. Mount the bottle holder (H7) to the central support tube (B) with the screws (J12).

Step 9: Alignment of the Feet

If the floor is uneven, you can stabilize the equipment by turning the two setting screws under the main frame.

1. Lift the equipment on the desired side and rotate the setting screws under the main frame.
2. Rotate the screws clockwise in order to remove them and to raise the equipment.
3. Rotate them counterclockwise in order to lower the equipment.

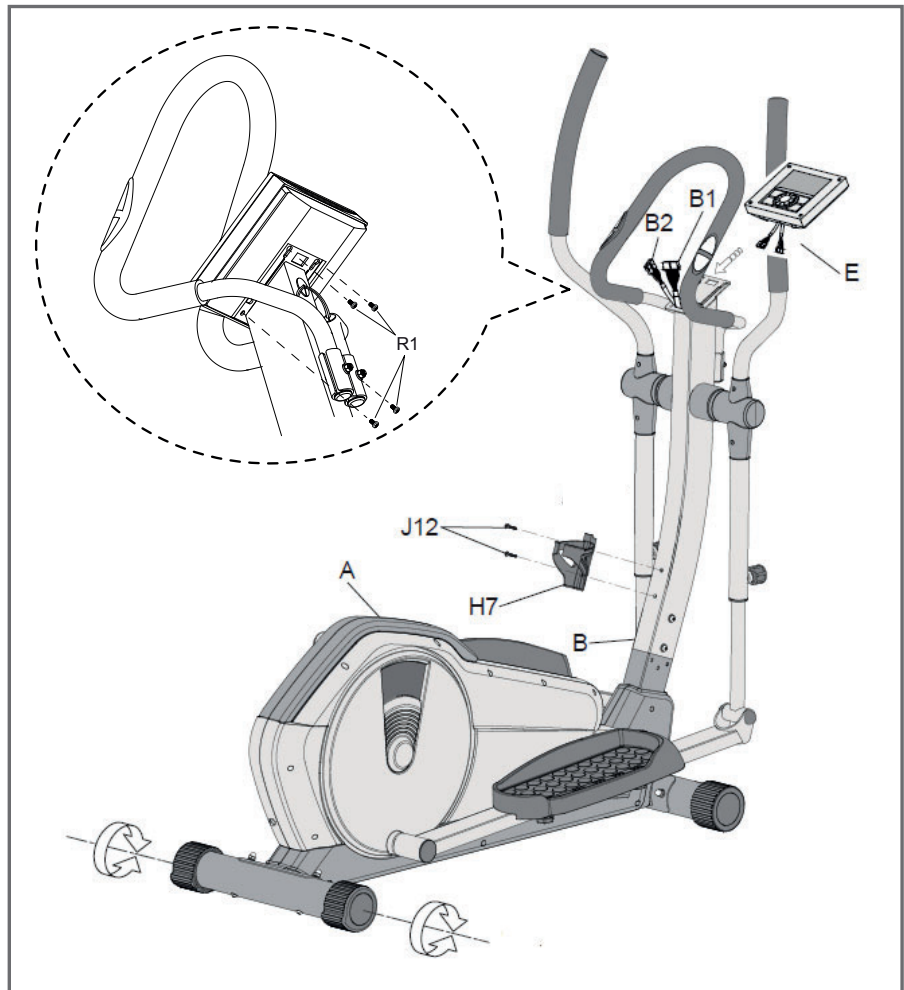

After completing the assembly, check that all screws are tight!

Step 10: Connecting the equipment to the mains supply

► ATTENTION

The equipment must not be connected to a multiple socket, otherwise it cannot be guaranteed that the equipment will be supplied with sufficient power. Technical errors can result.

Plug the power plug into a wall outlet that complies with the instructions in the chapter on electrical safety.

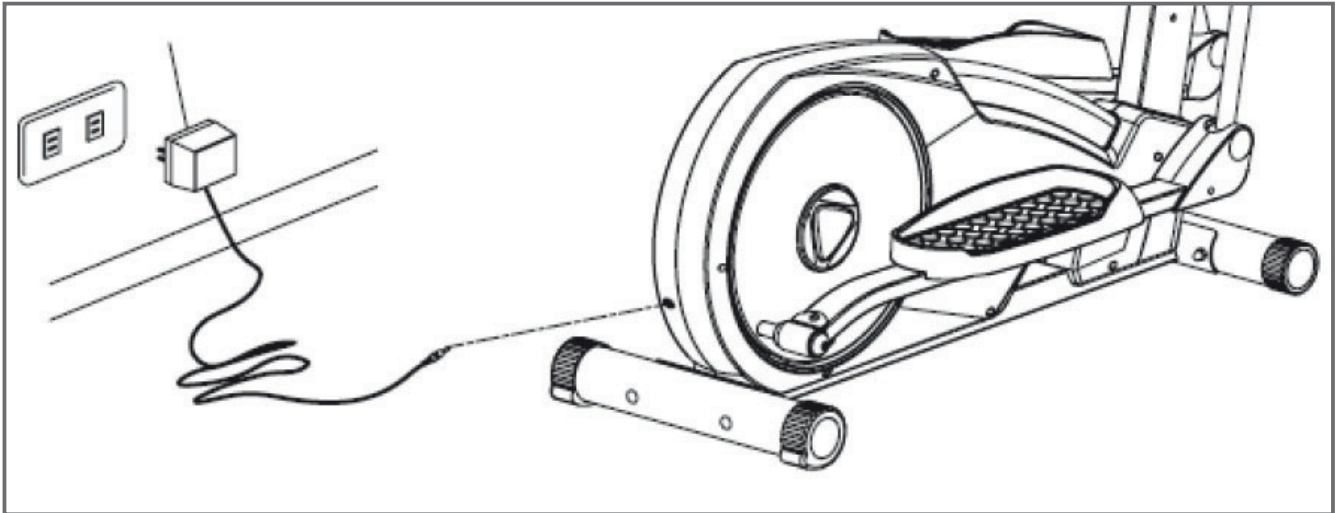

Correctly Getting On and Off

1. To get on, grip the handles with both hands and first step onto the left pedal with your left foot or onto the right pedal with your right foot and then place your foot onto the other pedal.
2. To get off, grip the handles with both hands and place one foot next to the equipment and then the other foot.

3 OPERATING INSTRUCTIONS

① NOTICE





- + Familiarise yourself with all the functions and setting options of the device before starting training. Have the proper use of this product explained to you by a specialist.
- + Always start your training with low intensity and increase evenly and gently. End your training with a cool-down phase. If you are unsure, please consult your physician.

3.1 Console Display

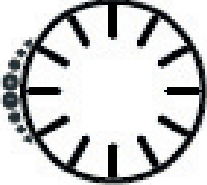

Time	Time runs ascending from 0:00 - 99:59 minutes. If you define a training time, the time will run descending to 0:00.
Speed	Indicates the current training speed between 0.0 - 99.9 km/h or mph.
RPM (cadence; rotations per minute)	Indicates current rotations per minute.
Distance	Distance shows ascending from 0.00 - 99.90 km/mi. If you define a training distance, the distance will count ascending to 0:00.
Calories	Calories count ascending from 0 - 999. If you define a calorie number, the calories will count descending to 0.
Pulse (heart rate; heart beats per minute)	As soon as you hold the hand pulse sensors, the console will indicate your current heart rate.
Recovery	After training, press the RECOVERY button and hold the hand pulse sensors. Then a 60-second countdown will start. After the countdown, your recovery heart rate will be displayed with F1-F6, whereby F1 is the best and F6 is the worst. Press the RECOVERY button again in order to return to the main menu.
Temperature	In the standby mode, the console indicates the room temperature.
Calender	In the standby mode, the console indicates the date.
Clock	In the standby mode, the console indicates the time.

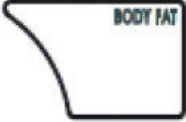





3.2 Button Functions



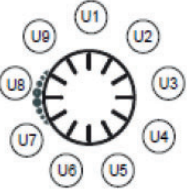

	<p>ENTER (press button)</p>	<p>Press this button to confirm a setting.</p>
	<p>ENTER (rotate button)</p>	<p>With this button, you can set training values and select the training mode.</p>
	<p>RESET</p>	<p>Press this button to reset all entered values and to return to the main menu.</p>
	<p>START/STOP</p>	<p>Press this button to start or stop the training.</p>
	<p>BODY FAT</p>	<p>Press this button to start the body fat test programme.</p>
	<p>RECOVERY</p>	<p>Press this button to measure your recovery heart rate.</p>

1. Turn the equipment on and a sound will be heard for two seconds. With the rotating button, select a user U1 - U9 and enter the following user data: gender, age, height, and weight. Use the rotating button to set the respective value and press the button to confirm.
2. Set the date and time with the enter button.
3. Use the enter button to select a training mode (Manual), Program, User Program, HRC, Watt and press enter to confirm.

3.3 Selecting and Setting the User Account

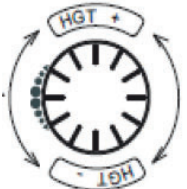
The console has nine user accounts (U1 - U9). Rotate the adjusting knob in order to select a user and press ENTER to confirm. Use the adjusting knob or the ENTER button to make settings for gender, age, height, and weight.

User selection U1 to U9		Setting gender		Setting age	
					
Turn left or right	Press enter	Turn left or right	Press enter	Turn left or right	Press enter

Setting height		Setting weight	
			
Turn left or right	Press enter	Turn left or right	Press enter







3.4 Programmes

Once you have entered all user values, you can select one of the following programme categories with the ARROW BUTTONS:

- Manual training programme: 1
- Pre-set training programmes: 12
- User-defined programme: 1
- Heart rate controlled training programme: 1
- Watt-controlled training programmes: 4





3.4.1 Manual Programme

1. Select "Manual" with the enter button and press Enter to confirm.
2. Then use the enter button to set a resistance level between 1 and 16.
3. After you have set the resistance level, you can define values for the time, distance, calories, and heart rate. To do this, turn the enter button and press it to confirm.
4. Press the start button to start the training.

Programme selection		Setting of resistance		Setting of training values		
						
Turn left or right	Press enter	Turn left or right	Press enter	Turn left or right	Press enter	Start training

3.4.2 Training Programme

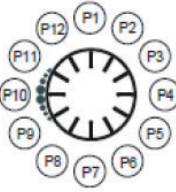
1. Select "Program" with the enter button and press Enter to confirm.
2. Then select a training programme between P1-P12 and press Enter to confirm. After two seconds, the training profile will be displayed.
3. After you have selected the training programme, you can select a resistance level between 1 and 16, which can be adjusted while training at any time.
4. Press the start button to start the training.



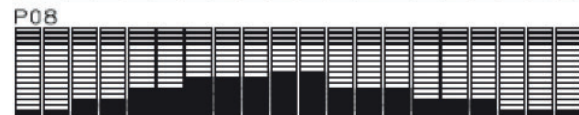
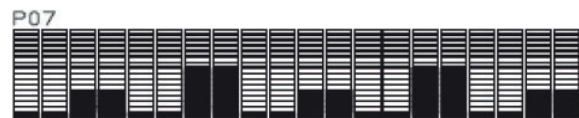
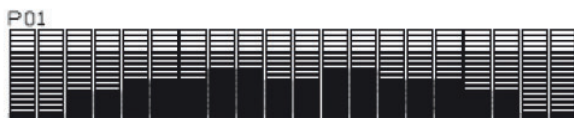

Programme selection		Training programme selection		
				
Turn left or right	Press enter	Turn left or right	Press enter	Start training

Training profiles



3.4.3 User-defined Programme

1. Select "User Program" with the enter button and press Enter to confirm.
2. Then you can set the resistance level for each of the 20 profile segments. Set the resistance with the rotating button and press enter to confirm.





Programme selection		Setting resistance for 20 profile segments		
				
Turn left or right	Press enter	Turn left or right	Press enter	Start training

3.4.4 Heart Rate Oriented Programmes

⚠ WARNING





Your training equipment is not a medical device. The heart rate measurement of this equipment may be inaccurate. Various factors can affect the accuracy of the heart rate measurement. The heart rate measurement serves only as a training aid.

1. Select "HRC Program" with the enter button and press Enter to confirm.
2. Then set your age with the enter button and press Enter to confirm. The console automatically calculates your maximum heart rate.
3. Now select your training heart rate (55%, 75%, 90% or target heart rate).

Programme selection		Setting of the training heart rate		
				
Turn left or right	Press enter	Turn left or right	Press enter	Start training

3.4.5 Watt-controlled Programme

1. Select "Watt Program" with the enter button and press Enter to confirm.
2. Set the wattage with the rotating button that you would like to train with (10 to 350).

Programme selection		Setting the wattage		
				
Turn left or right	Press enter	Turn left or right	Press enter	Start training

3.4.6 Body Fat Programme

1. Make sure that you have correctly entered your user data.
2. Press the body fat button and grab the hand pulse sensors.
3. On the display, "-----" will be displayed for eight seconds while the test is being executed. After eight seconds, your body fat percentage will be displayed in percent (*1) and your BMI (*2).

NOTICE

If you see "E-1" on the display, you have not correctly grabbed the hand pulse sensors.

Then press the body fat button to return to the training mode. The measurements are no longer displayed. If you would like to execute the test for another person, press the RESET button for four seconds. Then you can select or enter new user data and execute the test again.

*1 - BODY FAT - The console calculates your body fat percentage based on the user data and the measurement through the hand pulse sensors.

*2 - BMI - The body mass index evaluates the body weight of a person in relationship to their body size.

These values provide a rough guideline to evaluate your health.

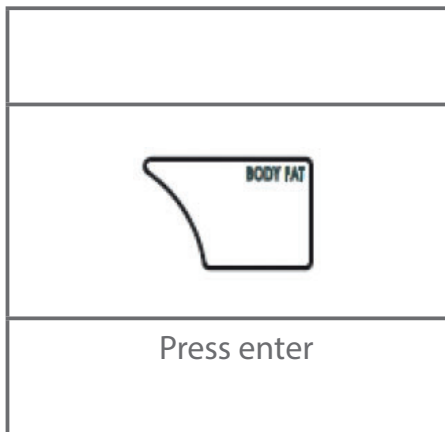

NOTICE

- + If the console does not receive a signal for four minutes, it will turn off automatically while all training values are saved. Press any button to turn the console back on.
- + The console can save preset training values for four users. If you turn on the console again, the last user will be displayed. For users U1-U4, the preset training values for time, distance, calories, and Watt (in the manual training) or heart rate will be displayed. Only the user will be displayed for users U5-U9.

Body fat table:

Symbol				
Gender / body fat %	Low	Low/medium	Medium	Medium/high
Male	<13%	13%-25,8%	26%-30%	>30%
Female	<23%	23%-35,8%	36%-40%	>40%

Battery installation

The console needs four "C" batteries, which you can install in the back side of the console as follows.

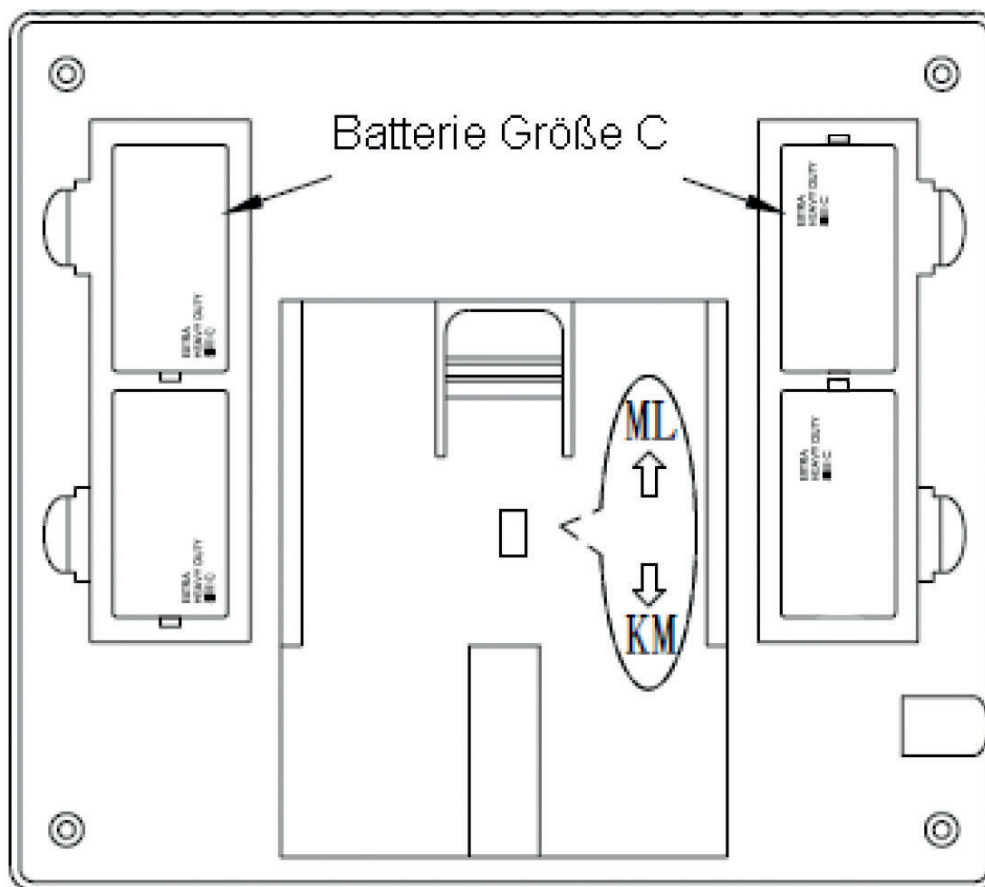

KM/ML switch:

With this switch, you can choose between metric and English units. After this, you must remove the plug and restart the console.

3.5 Heart-rate Measuring

Pulse measuring via hand sensors

The hand sensors integrated in the handles allow you to determine your heart rate. You can measure your heart rate by lightly grasping the sensors with both hands at the same time. Blood pressure changes occur due to the heartbeat. The sensors measure the changes to the electric skin resistance caused by it. These values are then used to create an average and are displayed on the screen of the console as a heart rate.

Note:

For some people, the skin resistance change caused by the heart rate is so minimal that the measurements do not allow for usable values. Strong callus or sweat on the hands may also impair a correct measurement. In such cases, the heart rate will not be shown at all or only incorrectly.

If the measurement is incorrect or not taken at all, please check if it happens to only one person or to several people. If the pulse display only does not work in a single case, the equipment is not defective. In this case, we recommend using a chest strap to achieve a permanently correct heart rate display.



WARNING

Your training equipment is not a medical device. The heart rate measurement of this equipment may be inaccurate. Various factors can affect the accuracy of the heart rate measurement. The heart rate measurement serves only as a training aid.

Telemetric heart rate measuring

This elliptical cross trainer is already equipped with a heart rate receiver as standard. Using a chest strap makes it possible for you to have a wireless heart rate measuring. This optimal and ECG-precise type of measuring reads the heart rate directly from the skin through a transmitting chest strap. The chest strap then sends the impulse to the receiver integrated in the console.

Positioning the chest strap and moistening the electrodes:

Place the belt directly below the chest, while the transmitter should be placed on the middle of the chest. The chest strap should sit comfortably, but not too loose. If the belt is too loose, the contact to the electrodes may be disrupted or the belt may slip while exercising. The transmitter turns on automatically once it is put on. In order to allow for a precise measuring, you should moisten the rubber electrodes. This is best done with a special chest strap contact gel, which is also used for ultrasound scans.

Note:

If you have not been active in doing sports for a longer period of time, you should first go to your physician in order to discuss your training with them. You should also contact your physician in advance in the event of heart problems, high/low blood pressure and obesity.

Training with heart rate orientation

Heart rate orientation guarantees an extremely effective and healthy training. Through your age and the following table, you can quickly and easily read and determine the optimal pulse for your training. An acoustic alarm will sound if your heart rate exceeds the set target heart rate. Which target heart rate is important for which training goal can be found out in the following.

Fat burning (weight management): The main goal here is to burn deposits of fat. In order to achieve this training goal, a low training intensity (approximately 55% of the maximum heart rate) and a longer training period are required.

Cardiovascular training (cardio training): The primary goal is to increase stamina and fitness through an improved provision of oxygen through the cardiovascular system. In order to achieve this training goal, medium intensity (approximately 75% of the maximum heart rate) with a medium training period is required.

Anaerobic (maximum) load training: The main goal of maximum load training is to improve recovery after short, intense loads in order to be able to quickly return to the aerobic zone. In order to achieve this training goal, a high intensity (approximately 90% of the maximum heart rate) with short, intense load is required, which is followed by a recovery phase in order to prevent muscle fatigue.

Example:

For a 45-year-old man or woman, the maximum heart rate is 175 ($220 - 45 = 175$).

- The fat burning target zone (55%) is at approximately 96 beats/min. = $(220 - \text{age}) \times 0.55$.
- The cardio target zone (75%) is at approximately 131 beats/min. = $(220 - \text{age}) \times 0.75$.
- The maximum heart rate for an anaerobic load training (90%) is at approximately 157 beats/min. = $(220 - \text{age}) \times 0.9$.

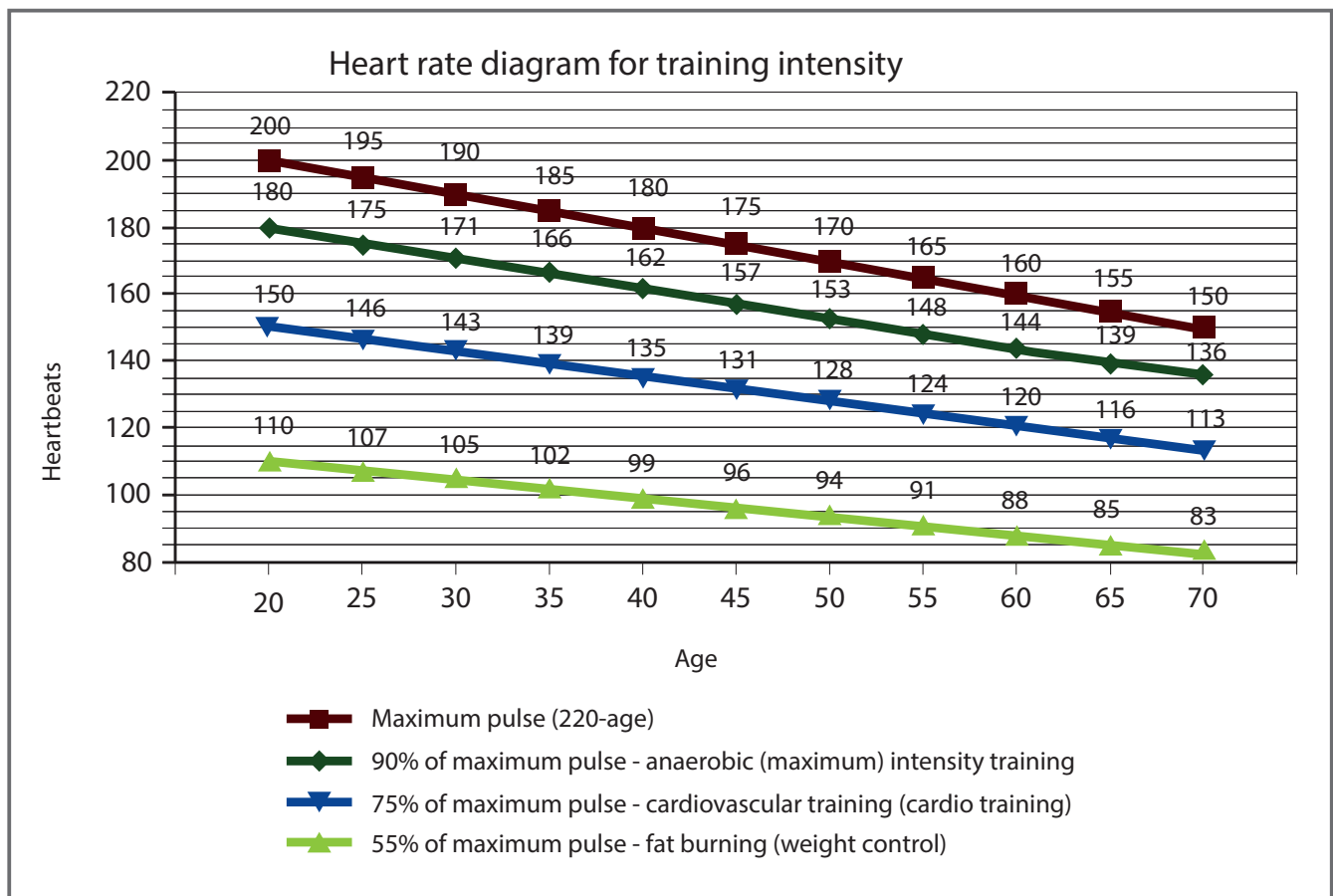

4.1 General Instructions

⚠ WARNING

- + The storage location should be chosen so that improper use by third parties or children can be prevented.
- + If your equipment does not have transportation wheels, the equipment must be disassembled before transportation.

▶ ATTENTION

- + Make sure that the equipment is protected from moisture, dust and dirt in the selected storage location. The storage location should be dry and well ventilated and have a constant ambient temperature between 10°C and 35°C.

4.2 Transportation Wheels

▶ ATTENTION

If you want to transport your equipment over particularly sensitive and soft floor coverings, such as parquet, planks or laminate, lay out the transport route with cardboard or similar to avoid possible floor damage.

1. Stand behind the equipment and lift it until the weight is transferred to the transportation wheels. After that, you easily can move the equipment to a new position. For long transport distances the equipment should be disassembled and safely packed.
2. Select the new location by following the instructions in the section 1.4 of this manual.

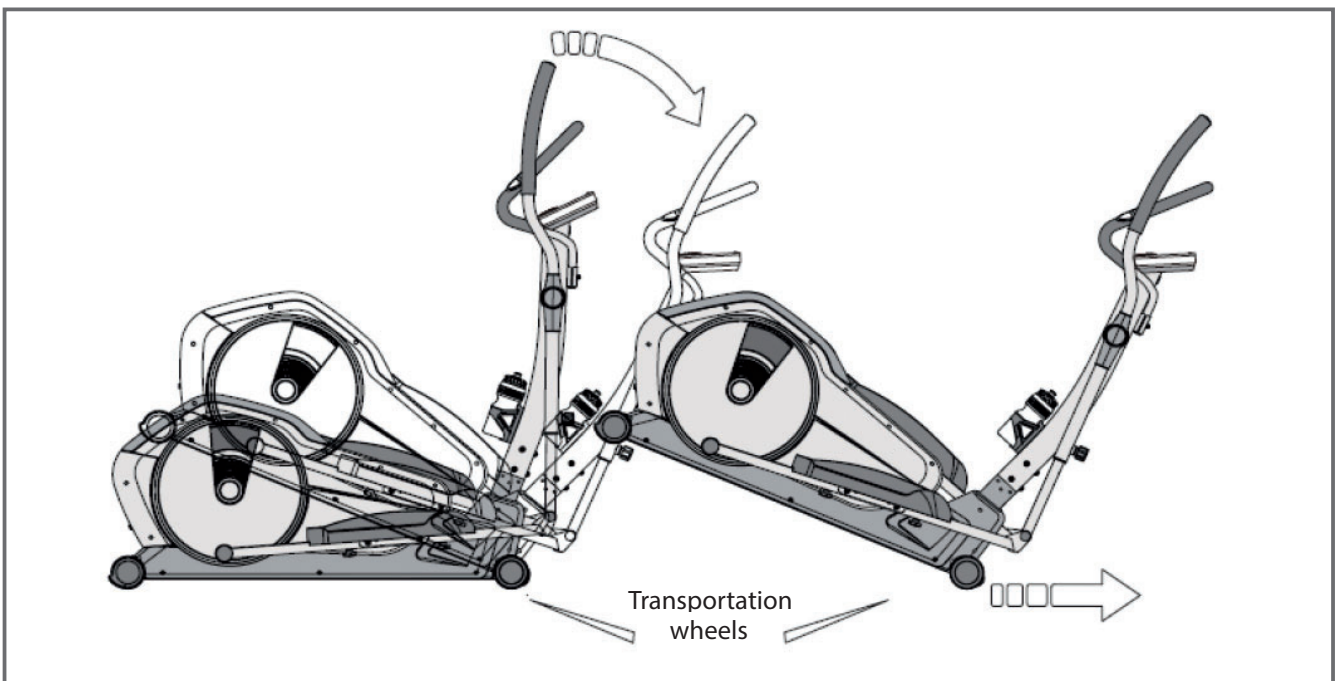

5.1 General Instructions



WARNING

- + Do not make any improper changes to the equipment.



CAUTION

- + Damaged or worn components may affect your safety and the life of the equipment. Therefore, immediately replace damaged or worn components. In such a case, contact the contract partner. The equipment must not be used until it has been repaired. If necessary, use only original spare parts.

▶ ATTENTION

- + In addition to the instructions and recommendations for maintenance and care given here, additional service and/or repair work may be necessary; this must only be carried out by authorised service technicians.

5.2 Faults and Fault Diagnosis

The equipment undergoes regular quality controls during production. Nevertheless, faults or malfunctions may occur. Frequently, individual parts are responsible for these disturbances, an exchange is usually sufficient. Please refer to the following overview for the most common errors and how to correct them. If the equipment still does not function properly, contact your contract partner.

Fault	Cause	Solution
Drive disks wobble/ make noises	Drive disk loose	Tighten nut (pay attention to left-hand / right-hand thread)
Display is blank/is not working	Loose cable connections	Check cable connections
Equipment wobbles	Equipment is not level	Align the feet
Creaking noises on the stepping area	Loose screws on stepping area	Tighten the screws on the stepping area
Creaking noises	Screw connections loosened or too tight	Check screw connections
Squeaking noises on the guide rails	Guide rails or rollers dirty or guide rails dry	Clean the guide rails and then lubricate them with a suitable lubricant

No pulse display	<ul style="list-style-type: none"> + Sources of interference in the room + unsuitable chest strap + Wrong position of chest strap + Chest strap defective or battery empty + Pulse display defective 	<ul style="list-style-type: none"> + Eliminate sources of interference (e.g. mobile phone, WLAN, lawn mower and vacuum cleaner robot, etc. ...) + Use a suitable chest strap (see RECOMMENDED ACCESSORIES). + Reposition chest strap and/or moisten electrodes + Changing batteries + Check if pulse display by hand pulse possible
------------------	---	--

5.3 Error Codes and Troubleshooting

The electronics of the equipment continuously carries out tests. In case of deviations, an error code appears on the display and normal operation is stopped for your safety.

Please contact the contract partner for technical support.

5.4 Maintenance and Inspection Calendar

To avoid damage from body sweat, the equipment must be cleaned with a damp towel (no solvents!) after each training session.

The following routine tasks must be performed at the specified intervals:

Part	Weekly	Monthly	Quarterly
Display console	C	I	
Slide rails*		C	
Lubrication of slide rails and moving parts*			I
Plastic covers	C	I	
Screws and cable connections		I	
Legend: C = clean; I = inspect			

*Make sure to always clean the slide rails and moving parts before re-lubricating.

By scanning the QR code with the camera function or QR code scanner app of your smartphone/tablet, a video on general maintenance of a crosstrainer opens on YouTube. The video serves to illustrate the maintenance points described in this manual.

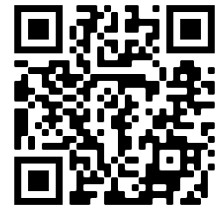

Please note that the video may not be available in your language or with appropriate subtitles.

If you cannot scan QR codes, you can access all Fitshop videos on YouTube by first opening YouTube and entering "Fitshop" in the search field.

6 DISPOSAL

At the end of its operational life, this equipment cannot be disposed of in normal household waste. Instead, it must be disposed of via an electricals recycling centre. Further information can be obtained from your local authority's recycling service.



The materials can be recycled as per their symbols. Through the reuse, recycling of materials or other forms of recovery of old equipment, you make an important contribution to the protection of the environment.

7 RECOMMENDED ACCESSORIES

To make your training experience even more efficient and pleasant, we recommend that you add suiting accessories to your fitness equipment. For elliptical cross trainers this could for example be a **floor mat**, which makes your fitness equipment stand more securely and also protects the floor from sweat or **silicone spray** to keep moving parts in good shape.

If you have purchased a fitness machine with pulse training and want to train your heart rate, we strongly recommend that you use a compatible **chest strap**, as this ensures optimum transmission of the heart rate.

Our range of accessories offers the highest quality and makes training even better. If you would like to find out more about compatible accessories, please go to the detail page of the product in our webshop (the easiest way is to enter the article number in the search field above) and go to the recommended accessories on this page. Alternatively, you can use the QR code provided. Of course, you can also contact our customer service: by telephone, e-mail, in one of our branches or via our social media channels. We will be happy to advise you!



floor mat



chest strap



chest strap contact gel



towels



silicone spray

8.1 Serial Number and Model Name

In order to provide you with the best possible service, please have the model name, article number, serial number, exploded drawing and parts list ready. The corresponding contact options can be found in chapter 10 of this operating manual.

NOTICE

The serial number of your equipment is unique. It's located on a white sticker. The exact position of this sticker is shown in the following illustration.



Enter the serial number in the appropriate field.

Serial number:

Brand / Category:

Model Name:

Article Number:

8.2 Parts List

No.	Qty.	Name	No.	Qty.	Name
A	1	Main Frame	A27	1	Nylon Nut
A1	1	Sensor Wire 1500Mm	A28	1	Belt
A2	1	Motor	A29	1	Driving Pully
A2-1	2	Motor-Screw	A30	1	Magnetic
A3	1	Tension Cable	A31	1	Crank Axle
A3-1	1	Spring	A32	4	Bolt M6x16l
A4	1	Dc Line 350Mm	A33	4	Spring Washer M6
A5	1	Sensor Wire 350Mm	A34	4	Nylon Nut M6
A5-1	2	Sensor Screw	A35	2	Bearing 6004Zz
A6	1	Flywheel	A36	2	C-Clip
A7	1	Axle	A37	2	Crank
A8	1	Bearing 6000Z	A38	2	Flange Nut M10
A8-1	1	Bearing 6300Z	A39	2	Plate Cover
A9	1	Bush M10x14x9t	A39-1	6	Screw
A10	4	Nut M10	A39-2	6	Washer
A11	2	Flange Nut M8	A40	2	Plastic Cover
A12	1	Magnetic Housing	A41	2	C-Clip
A13	1	Bolt M6x55l	A42	2	Bearing 2203Zz
A14	1	Nut M6	A43	2	Bolt M8
A15	1	Washer M6x19x1.5t	A44	2	End Cap
A16	1	Washer M6x14x1.2t	A45	1	Left Chain Cover
A17	1	Nylon Nut M6	A46	1	Right Chain Cover
A18	1	Bolt M8x45l	B	1	Central Support Tube
A19	1	Washer M8	B1	1	Sensor Wire 900Mm
A20	1	Nylon Nut M8	B2	1	Hand Pulse Wire 650Mm
A21	1	Pressing Tagger	B3	2	End Cap
A22	1	Spring	B4	1	End Plug
A23	1	Bolt M8x20l	C	1	Rear Stabilizer
A24	1	Washer M8x22x1t	C1	2	End Cap
A25	1	Nylon Nut M8	D	1	Front Stabilizer
A26	1	Pressing Pully			

D1	2	End Cap	H7	1	Bottle Holder
D2	2	Transportation Wheel	H9	1	Adopter
D2-1	4	Screw	J1	20	Washer M8
E	1	Console	J2	16	Spring Washer M8
F	1	Front Handle Bar	J3	4	Nut M8
F1	1	Iron Bracket	J4	10	Screw M8x16l
F2	1	Sponge	J5	2	Bolt M8x20l
F3	2	Hand Pulse Sensor	J6	2	Washer M8x25x2.3t
F3-1	2	Sensor Screw	J7	2	Wave Washer
F4	2	End Cap	J8	4	Screw D2.9x14l
F5	2	End Plug	J9	6	Washer M6
G1	1	Left Side Handle Bar	J10	2	Nylon Nut M6
G2	1	Right Side Handle Bar	J11	6	Spring Washer M6
G3	2	Knob	J12	2	Bottle Holder Screw M5
G4	2	Sponge	J13	6	Chain Cover Screw
G5	2	End Cap	J14	9	Chain Cover Screw
G6	4	Bearing 6003Zz			
G7	4	Bearing Housing			
G8	2	Plastic Insert			
G9	2	Pedal Connect Tube			
G10	2	Pedal Tube			
G11	2	Bolt M8x80l			
G12	2	Bush M8x12x58.8t			
G13	4	Bearing 6001Zz			
G14	2	Nylon Nut M8			
G15	4	End Cap			
H1	1	Left Pedal			
H1-1	1	Left Pedal Pad			
H2	1	Right Pedal			
H2-1	1	Right Pedal Pad			
H3	2	Handle Bar Join Cover			
H4	2	Handle Bar Join Cover			
H5	2	Iron Bracket			
H6	4	Knob			

8.3 Exploded Drawing

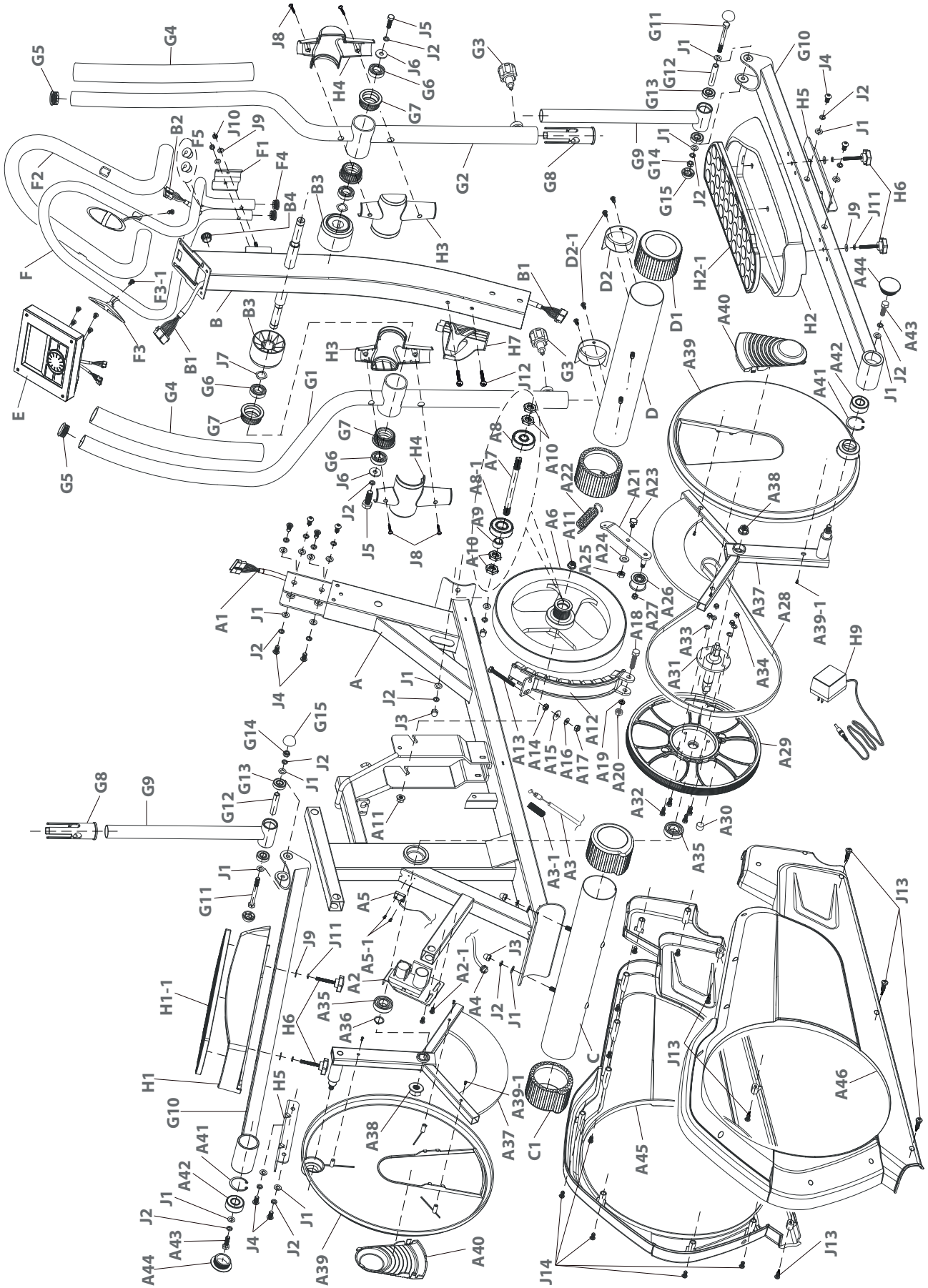

Products from cardiostrong® are subject to strict quality control. However, if a fitness equipment purchased from us does not work perfectly, we take it very seriously and ask you to contact our customer service as indicated. We are happy to help you by phone via our service hotline.

Error Descriptions

Your fitness equipment is developed for long-term, high-quality training. However, should a problem arise, please first read the operating instructions. For further assistance, please contact your contract partner or call our service hotline. To ensure your problem is solved as quickly as possible, please describe the defect as exactly as possible.

In addition to the statutory warranty, we provide a warranty for every fitness equipment purchased from us according to the following provisions.

Your statutory rights are not affected.

Warrantee

The warrantee is the first/original buyer and/or any person who received a newly purchased product as a gift from the original buyer.

Warranty period

The warranty periods, shown on our web shop, begin on delivery of the fitness equipment. The respective warranty periods for your equipment can be found on its product website.

Repair Costs

According to our choice, there will either be a repair, a replacement of individual damaged parts or a complete replacement. Spare parts, that have to be mounted while assembling the equipment, have to be replaced by the warrantee personally and are not a part of repair. After the expiration of the warranty period, the responsibility for parts costs, repair costs, installation costs and delivery costs lies with the warranty holder.

The terms of use are defined as follows:

- + Home use: solely for private use in private households up to 3 hours per day
- + Semi-professional use: up to 6 hours per day (e. g. rehabilitation centres, hotels, clubs, company gyms)
- + Professional use: more than 6 hours per day (e. g. commercial gyms)

Warranty Service

Within the warranty period, equipment which develops faults as a result of material or manufacturing defects, will be repaired or replaced at our discretion. Ownership of equipment or parts of equipment which have been replaced is transferred to us. The warranty period is not extended nor does a new warranty period begin following repair or replacement under the warranty.

Warranty Conditions

For the warranty to be valid, the following steps must be taken:

Please contact our customer service by email or phone. If the product under warranty has to be sent in for repair, the seller bears costs. After expiry of the warranty, the buyer bears the costs of transport and insurance. If the fault is covered by our warranty, you will receive a new or repaired equipment in return.

Warranty claims are invalid in case of damage resulting from:

- + misuse or improper handling
- + environmental influences (moisture, heat, electrical surge, dust, etc.)
- + failure to follow the current safety measures for the equipment
- + failure to follow the operating instructions
- + use of force (e. g. hitting, kicking, falling)
- + interventions which were not carried out by one of our authorized service centres
- + unauthorised repair attempts

Proof of Purchase and Serial Number

Please make sure that you are able to provide the appropriate receipt when claiming on your warranty. So that we can clearly identify the model of your equipment, and for the purposes of our quality control, you will need to give the serial number of your equipment, when contacting the service team. Where possible please have your serial number and your customer number ready when you call our service hotline. It will help us to deal with your request swiftly.

If you cannot find the serial number on your fitness equipment, our service team is at your disposal to offer further information.

Service outside of the Warranty Period

We are also happy to issue an individual cost estimate if there is a problem with your fitness equipment after the warranty has expired, or in cases which do not fall under the terms of the warranty, e. g. normal wear and tear. Please contact our customer service team to find a quick and cost-effective solution to your problem. In such a case you will be responsible for the delivery costs.

Communication

Many problems can be solved just by speaking to us as your specialist supplier. We know how important it is to you as a user of the fitness equipment to have problems solved quickly and simply, so you can enjoy working out with minimal interruption. For that reason, we also want to resolve your queries quickly and in a straightforward manner. Thus, please always keep your customer number and the serial number of the faulty equipment handy.

DE	DK	UK
<p>TECHNIK</p> <p>☎ +49 4621 4210-900 ☎ +49 4621 4210-698 ✉ technik@fitshop.de 🕒 Öffnungszeiten entnehmen Sie unserer Homepage.</p> <p>SERVICE</p> <p>☎ 0800 20 20277 (kostenlos) ☎ 04621 4210 - 0 ✉ info@fitshop.de 🕒 Öffnungszeiten entnehmen Sie unserer Homepage: https://stg.fit/statita</p>	<p>TEKNIK OG SERVICE</p> <p>☎ 80 90 16 50 ☎ +49 4621 4210-945 ✉ info@fitshop.dk 🕒 Åbningstider kan findes på hjemmesiden: https://stg.fit/statit7</p>	<p>CUSTOMER SUPPORT</p> <p>☎ 00800 2020 2772 ☎ +494621 4210 944 ✉ info@fitshop.co.uk 🕒 You can find the opening hours on our homepage: https://stg.fit/statitic</p>
	FR	BE
	<p>TECHNIQUE & SERVICE</p> <p>☎ +33 (0) 189 530984 ☎ +49 4621 42 10 933 ✉ info@fitshop.fr 🕒 Vous trouverez les heures d'ouverture sur notre site Internet: https://stg.fit/statit4</p>	<p>TECHNIQUE & SERVICE</p> <p>☎ 02 732 46 77 ☎ +49 4621 4210 933 ✉ info@fitshop.be 🕒 Vous trouverez les heures d'ouverture sur notre site Internet: https://stg.fit/statit8</p>
ES	NL	INT
<p>TECNOLOGÍA Y SERVICIOS</p> <p>☎ 911 238 029 ✉ info@fitshop.es 🕒 Consulta nuestro horario de apertura en la página web: https://stg.fit/statit5</p>	<p>TECHNISCHE DIENST & SERVICE</p> <p>☎ +31 172 619961 ✉ service@fitshop.nl 🕒 De openingstijden vindt u op onze homepage: https://stg.fit/statit3</p>	<p>TECHNICAL SUPPORT & SERVICE</p> <p>☎ +49 4621 4210-944 ✉ service-int@fitshop.de 🕒 You can find the opening hours on our homepage: https://stg.fit/statita</p>
PL	AT	CH
<p>DZIAŁ TECHNICZNY I SERWIS</p> <p>☎ 22 307 43 21 ☎ +49 4621 42 10-948 ✉ info@fitshop.pl 🕒 Godziny otwarcia można znaleźć na stronie głównej: https://stg.fit/statit6</p>	<p>TECHNIK & SERVICE</p> <p>☎ 0800 20 20277 (Freecall) ☎ +49 4621 42 10-0 ✉ info@fitshop.at 🕒 Öffnungszeiten entnehmen Sie unserer Homepage: https://stg.fit/statitb</p>	<p>TECHNIK & SERVICE</p> <p>☎ 0800 202 027 ☎ +49 4621 42 10-0 ✉ info@fitshop.ch 🕒 Öffnungszeiten entnehmen Sie unserer Homepage: https://stg.fit/statit9</p>

Please find a detailed overview including address and opening hours for all stores of the Fitshop Group in Germany and abroad on the following website:

www.fitshop.com/en/stores

WE LIVE FITNESS

WEBSHOP AND SOCIAL MEDIA

Fitshop is Europe's largest specialist store for home fitness equipment with currently over 70 stores and one of the world's most renowned online mail order companies for fitness equipment. Private customers order via the 25 web shops in the respective national language or have their desired equipment assembled on site. In addition, the company supplies fitness studios, hotels, sports clubs, companies and physio practices with professional equipment for endurance and strength training.

Fitshop offers a wide range of fitness equipment from renowned manufacturers, high-quality in-house developments and comprehensive services, such as a build-up service and sports scientific advice before and after the purchase. The company employs numerous sports scientists, fitness trainers and competitive athletes.

Visit us also on our social media platforms or our blog!

	www.fitshop.co.uk www.fitshop.de/blog
---	--

	www.facebook.com/fitshop.co.uk
---	--

	www.instagram.com/fitshop_uk
--	--

	www.youtube.com/@fitshop_uk
---	--

TAURUS

 cardiostrong

BODYCRAFT

 cardiojump

 **DUKEFITNESS**

DARWIN

Notes

