



Assembly and Operating Instructions



max. 136 kg



~ 90 Min.



70 kg

L 126 | W 53 | H 162

FSCSTEX60TOUCH.01.01

Art. No. CST-EX60-TOUCH

Crosstrainer **EX60** Touch

Content

1	GENERAL INFORMATION	8
1.1	Technical Data	8
1.2	Personal Safety	9
1.3	Electrical Safety	10
1.4	Set-Up Place	11
2	ASSEMBLY	12
2.1	General Instructions	12
2.2	Scope of Delivery	13
2.3	Assembly	14
3	OPERATING INSTRUCTIONS	20
3.1	Console Display	20
3.2	Button Functions	21
3.3	Switching On and Initial Settings	22
3.4	Programmes	24
3.4.1	Quick-Start Programme	24
3.4.2	Manual Programme	25
3.4.3	Pre-Set Programmes	25
3.4.4	Watt Programme	26
3.4.5	Heart Rate Controlled Programmes	26
3.5	Recovery Function	27
3.6	Training Record	28
3.7	Multimedia and Software Updates	29
3.7.1	Retrieving Apps from the Main Menu	30
3.7.2	Access to Apps During Your Workout	30
3.8	Bluetooth and Fitness Apps	31
4	STORAGE AND TRANSPORT	32
4.1	General Instructions	32
4.2	Transportation Wheels	32
5	TROUBLESHOOTING, CARE AND MAINTENANCE	33
5.1	General Instructions	33
5.2	Faults and Fault Diagnosis	33
5.4	Error Codes and Troubleshooting	34
5.3	Maintenance and Inspection Calendar	34
6	DISPOSAL	35

7	RECOMMENDED ACCESSORIES	36
8	ORDERING SPARE PARTS	37
8.1	Serial Number and Model Name	37
8.2	Parts List	38
8.3	Exploded Drawing	41
9	WARRANTY	42
10	CONTACT	44

Dear customer,

thank you for choosing fitness equipment from cardiostrong®. cardiostrong offers high-quality home fitness equipment that is optimally adapted to the conditions at home. Train at home no matter what the weather or time of the day. cardiostrong fitness equipment offers training programmes and a variety of equipment for all training levels and all training goals. Further information can be found at www.fitshop.com or www.cardiostrong.de. We hope you enjoy your training!

Intended Use

The equipment may only be used for its intended purpose.

The equipment is only suitable for home use. The equipment is not suitable for semi-professional (e.g. hospitals, associations, hotels, schools, etc.) and commercial or professional use (e.g. fitness studios).

Legal Notice

Fitshop GmbH
Europe's No. 1 for home fitness

International Headquarters
Flensburger Straße 55
24837 Schleswig
Germany

Management:
Christian Grau
Sebastian Campmann
Dr. Bernhard Schenkel
No. HRB 1000 SL
Local Court Flensburg
European VAT Number: DE813211547

Disclaimer

© cardiostrong is a registered brand of the company Fitshop GmbH. All rights reserved. Any use of this trademark without the explicit written permission of Fitshop is prohibited.

Product and manual are subject to change. Technical data can be changed without advance notice.

FITSHOP

Europe's No.1 for Home Fitness

ABOUT THIS MANUAL

Please carefully read the entire manual before installation and first use. The manual will help you to quickly set up the system and explains how to safely use it. Make sure that all persons exercising with the equipment (especially children and persons with physical, sensory, mental or motor disabilities) are informed about this manual and its contents in advance. In case of doubt, responsible persons must supervise the use of the equipment.

Due to ongoing changes and software optimisations, the manual may have to be updated. If you notice any discrepancies during assembly or use, please refer to the manual uploaded to the webshop. The latest manual is always available there.

This equipment has been manufactured according to the latest safety knowledge. As far as possible, potential safety hazards which could cause injury have been eliminated. Make sure to carefully follow the instructions and that all parts are securely in place. If required, read through the instructions again to correct any mistakes.



Training devices must be classified according to accuracy and use. Accuracy classes are only applicable to devices that display training data.

Accuracy classes

Class A: high accuracy.

Class B: medium accuracy.

Class C: low accuracy.

The use classes explain the intended use of the training device.

Use classes

Class S (studio): professional and/or commercial use.

These training devices are intended for the use in training rooms of facilities such as sports clubs, school facilities, hotels, clubs and studios whose access and supervision is specifically regulated by the owner (person with legal responsibility).

Class H (home use): use at home.

These stationary training devices are intended for the use in private homes where access to the training device is regulated by the owner (person with legal responsibility).

Please pay close attention to the safety and maintenance instructions given here. The contract partner cannot be held liable for damage to health, accidents or damage to the equipment when it is not used in accordance with these instructions.

The following safety instructions may appear in this manual:

► **ATTENTION**

This notice indicates potentially hazardous situations which, if not avoided, may result in property damage.

⚠ **CAUTION**

This notice indicates potentially hazardous situations which, if not avoided, may result in slight or minor injuries!

⚠ **WARNING**

This notice indicates potentially hazardous situations which, if not avoided, may result in death or serious injuries!

⚠ **DANGER**

This notice indicates potentially hazardous situations which, if not avoided, will result in death or serious injuries!

ⓘ **NOTICE**

This notice indicates further useful information.

Retain these instructions in a safe place for future reference, maintenance or when ordering replacement parts.

1.1 Technical Data

TFT display of

- + speed in km/h
- + training time in min
- + training distance in km
- + cadence (rotations per minute)
- + calories burnt in kcal
- + heart rate (when using the hand sensors or a chest strap)
- + Watt
- + resistance level

Resistance system:	electronic magnetic brake system
Resistance level:	16
Min. and max. wattage at 60 RPM:	45 - 294 Watt
Min. and max. wattage at 100 RPM:	140 - 560 Watt
Adjustable range in the Watt programme:	10 - 400 Watt (adjustable in 1-Watt increments)

User memory:	4
Quick Start programmes:	1
Manual programmes:	3
Pre-set programmes:	60
Watt-controlled programmes:	1
Heart rate controlled programmes:	4

Balance mass (2x):	Front: 12kg high speed. Back: 9 kg
Stride length:	40 cm
Stride height:	17 cm
Stride width:	18 cm

Weight and dimensions:

Article weight (gross, including packaging):	76.8 kg
Article weight (net, without packaging):	70 kg
Packaging dimensions (L x W x H) approx.:	141 cm x 45 cm x 73 cm
Set-up dimensions (L x W x H) approx.:	126 cm x 53 cm x 162 cm

Maximum user weight:	136 kg
----------------------	--------

Use class:	H
------------	---

1.2 Personal Safety

DANGER

- + Before you start using the equipment, you should consult your physician that this type of exercise is suitable for you from a health perspective. Particularly affected are persons who: have a hereditary disposition to high blood pressure or heart disease, are over the age of 45, smoke, have high cholesterol values, are overweight and/or have not exercised regularly in the past year. If you are under medical treatment that affects your heart rate, medical advice is absolutely essential.
- + Note that excessive training can seriously endanger your health. Please also note that heart rate monitoring systems can be inaccurate. If you notice any signs of weakness, nausea, dizziness, pain, shortness of breath, or other abnormal symptoms, stop exercising immediately and seek advice from your doctor if necessary.
- + The owner must communicate all warnings and instructions to the user.

WARNING

- + This equipment may not be used by children under the age of 14.
- + Children should not be allowed unsupervised access to the equipment.
- + Persons with disabilities must have a medical license and must be under strict observation when using the equipment.
- + Remember that your device does not have a freewheel function. Therefore moving parts cannot be stopped immediately.
- + Note that the individual physical power required to perform an exercise may differ from the displayed mechanical power.
- + When ascending and descending, make sure that one of the treads is in the lowest position.
- + The equipment is strictly for use by one person at a time.
- + Keep your hands, feet and other body parts, hair, clothing, jewellery and other objects well clear of moving parts.
- + During use, wear suitable sports clothing rather than loose or baggy clothing. When wearing sports shoes, make sure they have suitable soles, preferably made of rubber or other non-slip materials. Shoes with heels, leather soles, studs or spikes are unsuitable. Never exercise barefoot.

CAUTION

- + If your equipment needs to be connected to the power supply with a mains cable, make sure that the cable is not a potential tripping hazard.
- + Make sure that nobody is within the range of motion of the equipment during training so as not to endanger you or other persons.
- + Do not insert any objects of any kind into the openings of the device.
- + Be aware that if adjustment devices are left protruding, they may impede the user's movement.

1.3 Electrical Safety

DANGER

- + In order to reduce the risk of an electric shock, always unplug the equipment from the mains socket immediately after your workout, before assembly or dismantling, and before maintenance or cleaning. Do not pull on the cable.

WARNING

- + Do not leave the equipment unattended while the mains cable is plugged into the mains socket. During your absence, the mains cable must be removed from the mains socket to prevent improper use by third parties or children.
- + If the mains cable or plug is damaged or defective, contact your contract partner. Until repair, the equipment must not be used.

ATTENTION

- + The equipment requires a mains connection of 220-230 V with 50 Hz mains voltage.
- + The equipment may only be connected directly to an earthed socket using the supplied mains cable. Extension cables must conform to VDE guidelines. Always completely unwind the mains cable.
- + The socket must be protected by a fuse with a minimum fuse rating of "16 A, slow blow".
- + Do not make any changes to the mains cable or the mains plug.
- + Keep the mains cable away from water, heat, oil and sharp edges. Do not route the mains cable underneath the equipment or under a carpet or rug, and do not place any objects on top of it.
- + If your purchased item is equipped with a TFT console, software updates must be carried out regularly. Follow the instructions on the console to perform the update(s).
- + The software systems on gym equipment with TFT consoles are set up only for the pre-installed apps. Do not install any additional apps.

NOTICE

- + The pre-installed apps on TFT consoles are produced and provided by external manufacturers. Fitshop does not take any responsibility for the availability, functionality or contents of these apps.

1.4 Set-Up Place

WARNING

- + Do not place the equipment in main corridors or escape routes.

CAUTION

- + Choose a location in which to place the equipment such that there is enough free space/clearance to the front, the rear and to the sides of the equipment.
- + The training room should be well ventilated during training and not be exposed to any draughts.
- + Choose the place in which to set up the equipment such that there is enough free space/clearance to the front, the rear and to the sides of the equipment.
- + The free area in the direction from which the exercise equipment is accessed must be at least 0.6 m larger than the exercise area.
- + The set-up and mounting surface of the equipment should be flat, loadable and solid.

ATTENTION

- + The device may only be used in one building, in sufficiently tempered and dry rooms (ambient temperatures between 10°C and 35°C). The equipment should not be used outdoors or in rooms with high humidity (over 70%) like swimming pools.
- + A floor protective mat/equipment underlay can help to protect high-quality floor coverings (parquet, laminate, cork, carpets) from dents and sweat and can help to level out slight unevenness.
- + For Class S equipment, the exercise equipment may only be used in areas where access, supervision and control are specifically regulated by the owner.

2.1 General Instructions



DANGER

- + Do not leave any tools, packaging materials such as foils or small parts lying around, as otherwise there is a danger of suffocation for children. Keep children away from the equipment during assembly.



WARNING

- + Pay attention to the instructions attached to the equipment in order to reduce the risk of injuries.



CAUTION

- + Ensure to have sufficient room for movement in each direction during assembly.
- + The assembly of the equipment must be carried out by at least two adults. If in doubt, seek the help of a third technically skilled person.



ATTENTION

- + To prevent damage to the equipment and the floor, assemble the equipment on a mat or packaging board.



NOTICE

- + In order to make the assembly as simple as possible, some screws and nuts to be used can already be pre-assembled.
- + Ideally, assemble the equipment at its later set-up place.

2.2 Scope of Delivery

The scope of delivery consist of the following parts. At the beginning, check whether all parts and tools belonging to the device are included in the scope of delivery and whether damage has occurred. In the event of complaints, the contractual partner must be contacted directly.

⚠ CAUTION

If parts of the scope of delivery are missing or damaged, the assembly must not be carried out.

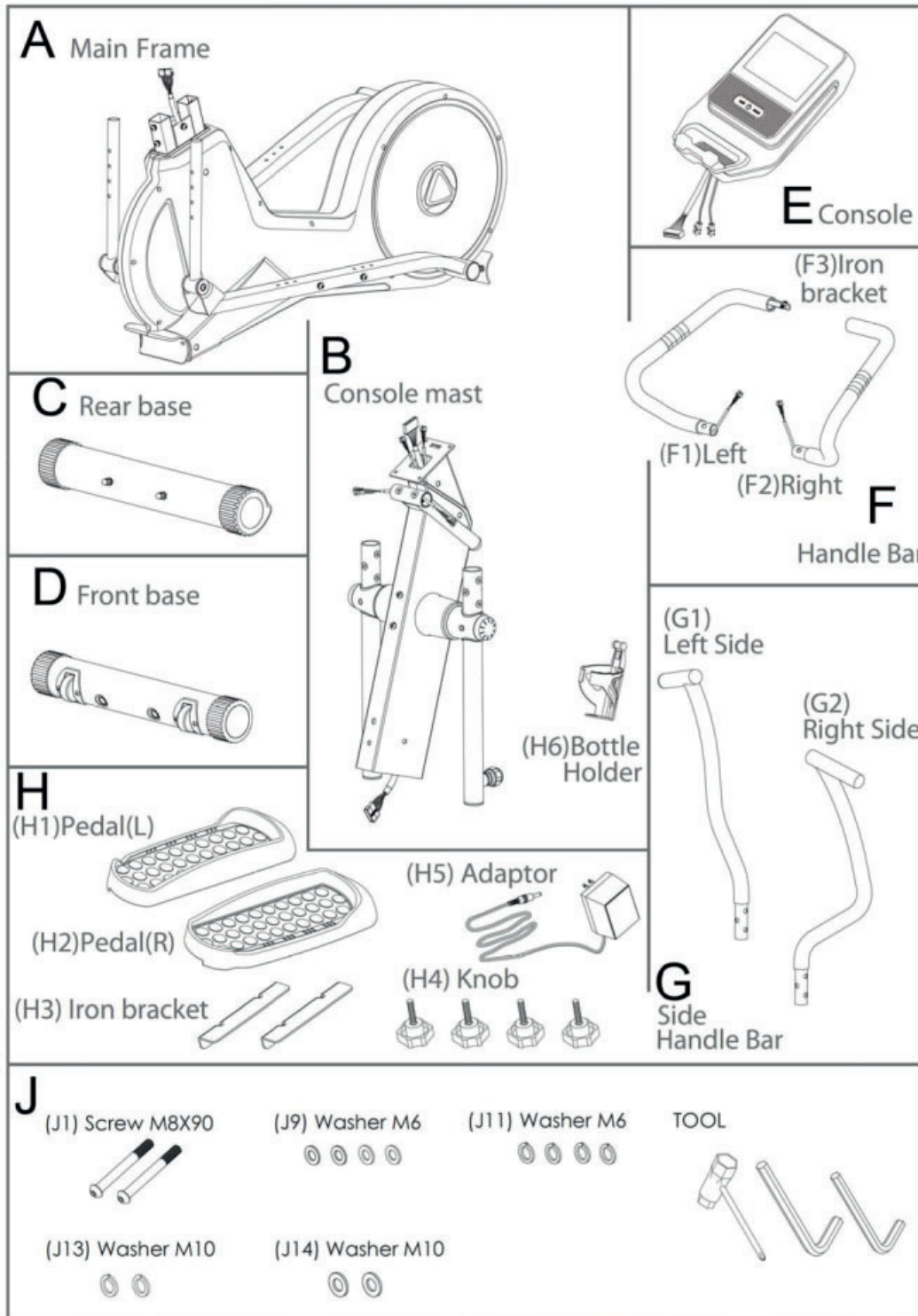

2.3 Assembly

Before assembly, take a close look at the individual assembly steps shown and carry out the assembly in the order given.

① NOTICE

- + First loosely screw all parts together and check that they fit properly. Tighten the screws using the tool only when you are instructed to do so.
- + If you have difficulty recognising the graphics, we recommend that you open and/or download the PDF instructions stored in the webshop on your end device (e.g. smartphone, tablet or PC). There you have the option of zooming in closer. Please note that the Adobe Acrobat Reader programme must be installed on your end device in order to open the file.

Step 1: Assembly of the Rear Stabilizer

1. Remove the pre-assembled washers (C2), spring washers (C3) and nuts (C4) from the rear stabilizer (C).
2. Mount the rear stabilizer (C) to the rear bracket on the main frame (A) using two screws (C1), two washers (C2), two spring washers (C3) and two nuts (C4).
3. Tighten the screws.

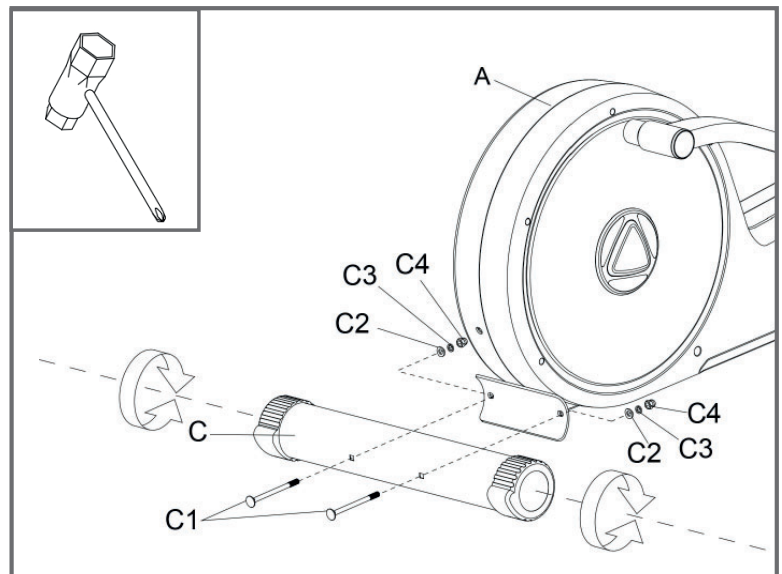

Step 2: Assembly of the Front Stabilizer

1. Mount the front stabilizer (D) to the main frame (A) using two screws (J1), two spring washers (J13) and two washers (J14).
2. Tighten the screws.

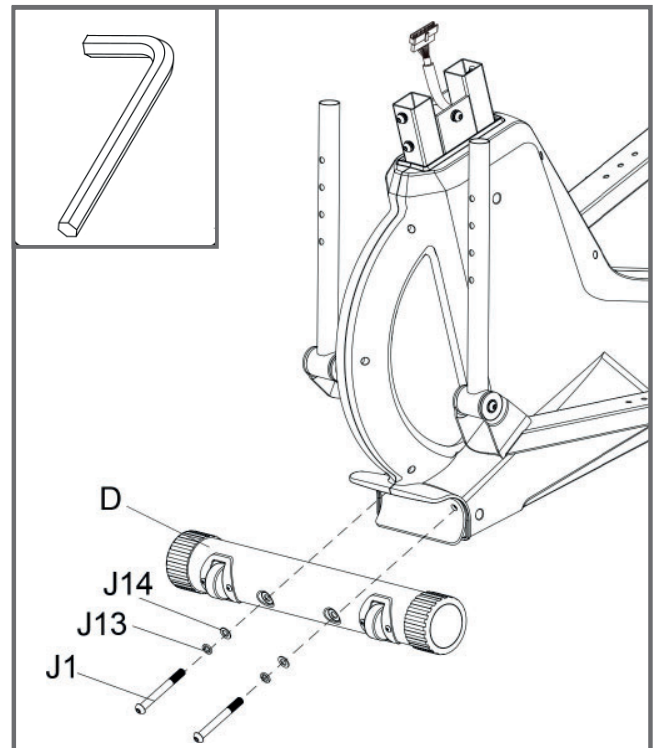

Step 3: Assembly of the Console Mast

1. Remove pre-assembled the screws (J4), spring washers (J2) and washers (J3) from the main frame (A).
2. Connect the sensor wire (A1) to the sensor wire (B1).

► **ATTENTION**

Pay attention to not pinch the cables during the next step.

3. Mount the console mast (B) to the main frame (A) using six screws (J4), six spring washers (J2) and six washers (J3).
4. Tighten the screws.

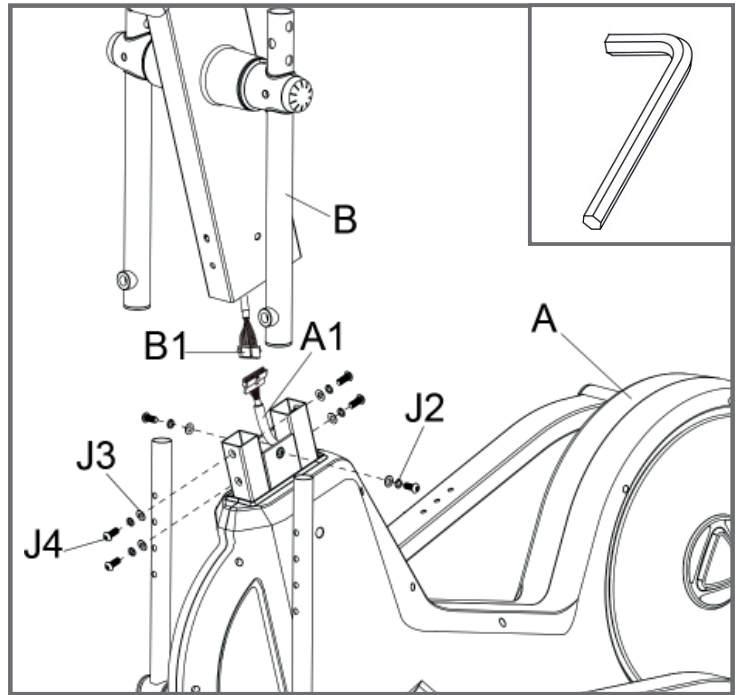

Step 4: Assembly of the Side Handle Bars

1. Mount the side handle bars (G1 and G2) to the support tube (B) using two screws (J5) and one screw (J6) each, see fig. F.
2. Tighten the screws.

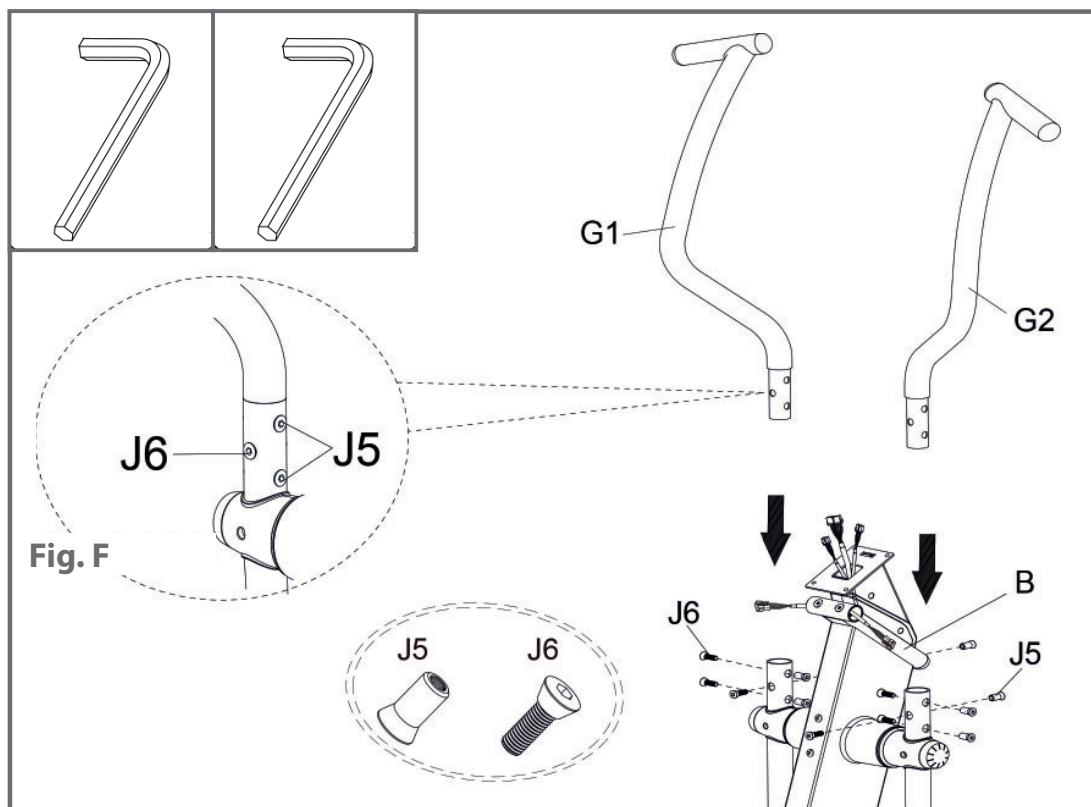

Step 5: Assembly of the Brackets and locking the Pedal Arms

1. Remove the pre-assembled screws (J7), spring washers (J2) and washers (J3).
2. Mount the bracket (H3) to the right pedal arm using two screws (J7), two spring washers (J2) and two washers (J3).
3. Repeat the previous step for the left side.
4. Set a position for the height of the pedal arms and fix the position by tightening the knob (G3).

NOTICE
The pedal arms can be set to four different heights.

5. Tighten the screws and the knob.

CAUTION
To prevent falls, the pedal arm should be at the same height on both sides.

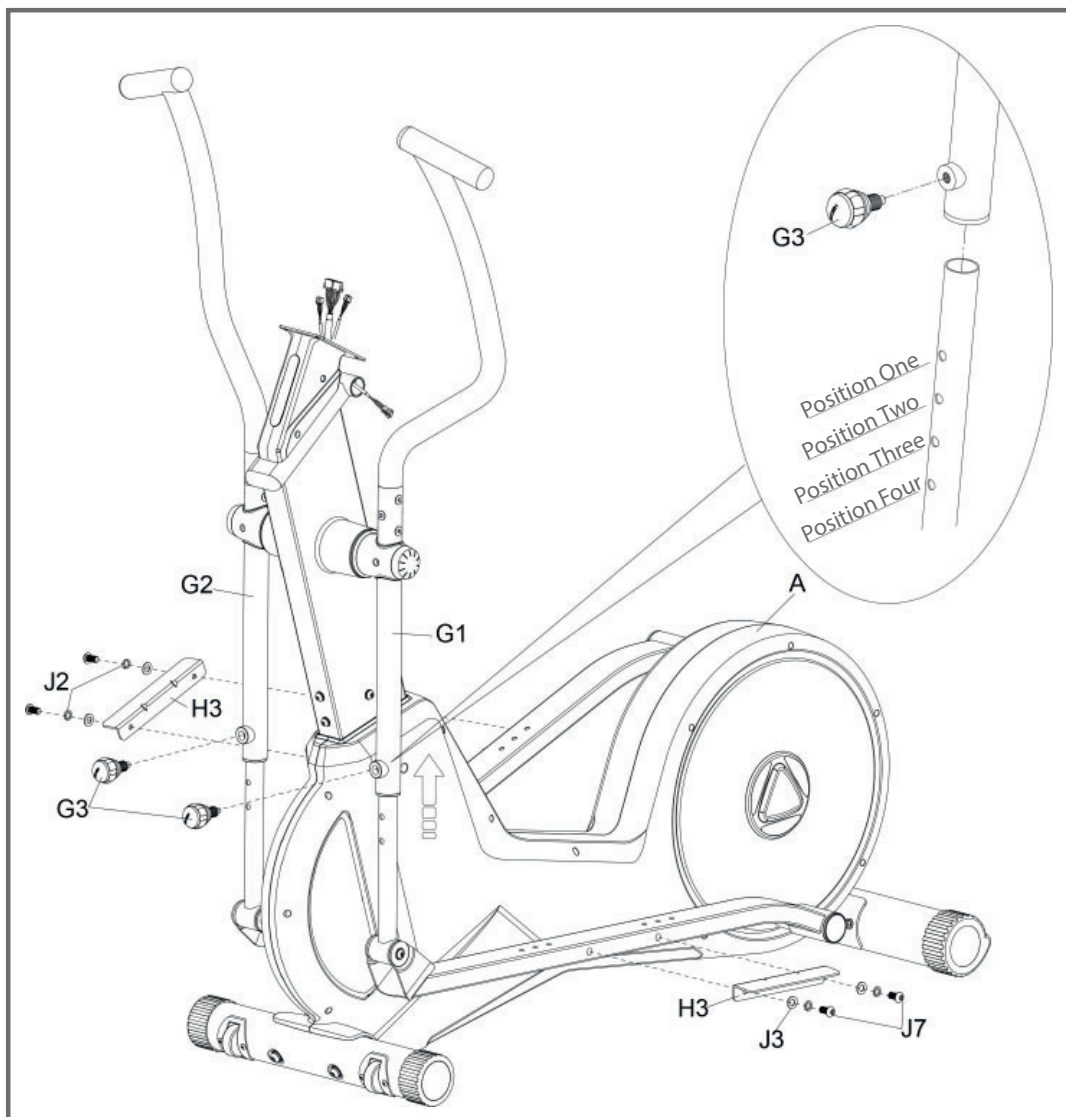

Step 6: Assembly of the Pedals

NOTICE

The pedals can be mounted in three different positions.

1. Mount the right pedal (H2) to the pedal arm using two washers (J9), two spring washers (J11) and two knobs (H4).
2. Repeat the previous step for the left side.
3. Tighten the knobs (H4).

CAUTION

To prevent falls, make sure that the pedals are in the same position on both sides and that the knob (H4) is always tightened firmly.

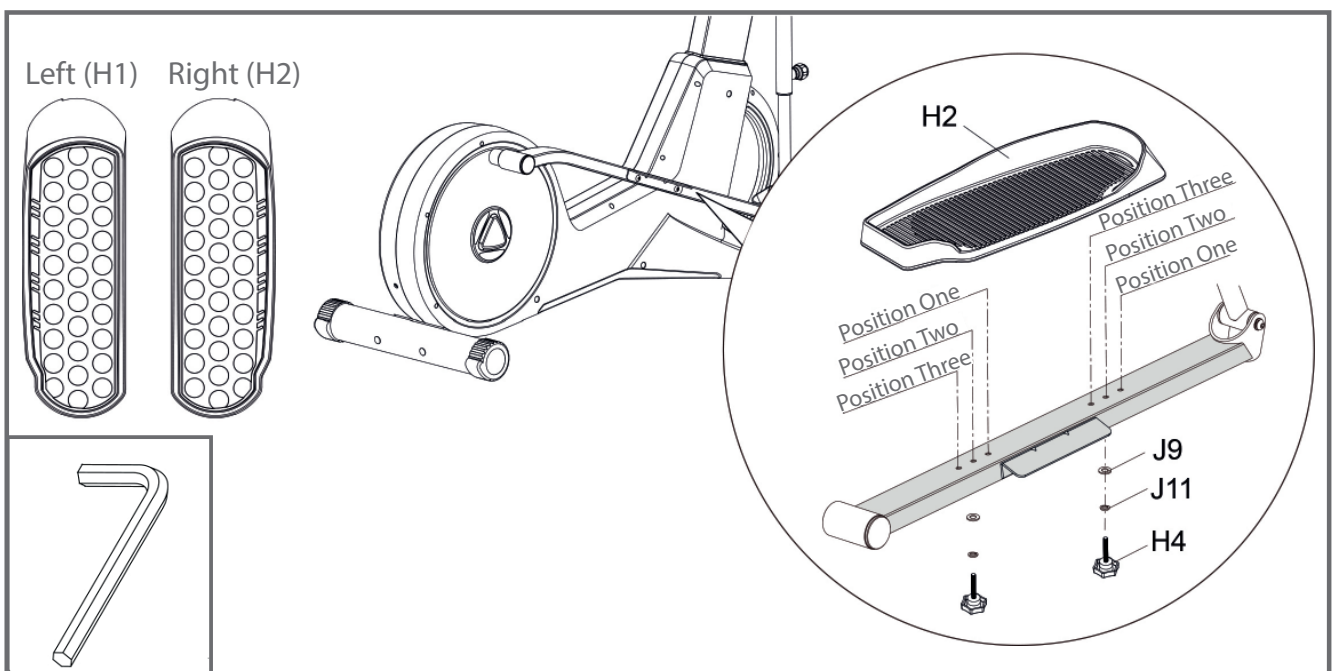

Step 7: Assembly of the Sonsole, Handle Bars and Bottle Holder

► ATTENTION

Pay attention to not pinch the cables during the next steps.

1. Connect the cables of the handle bars (F1 and F2) to the cables on the console mast (B) and slide both handle bars into the bracket on the console mast (B).
2. Mount the handle bars (F1 and F2) to the console mast using two screws (J10) and connect the handle bars (F1 and F2) by the bracket (F3) using one screw (J12).
3. Connect the sensor wires (B1 and B2) to the wires of the console (E).
4. Remove the pre-assembled screws (J15) from the console (E) and mount the console (E) to the console mast (B) using the previously removed four screws (J15).
5. Remove the pre-assembled screws (B4) from the console mast (B) and mount the bottle holder (H6) to the console mast (B) using the previously removed two screws (B4).
6. Tighten the screws.

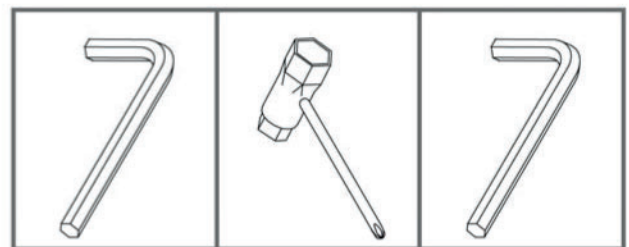
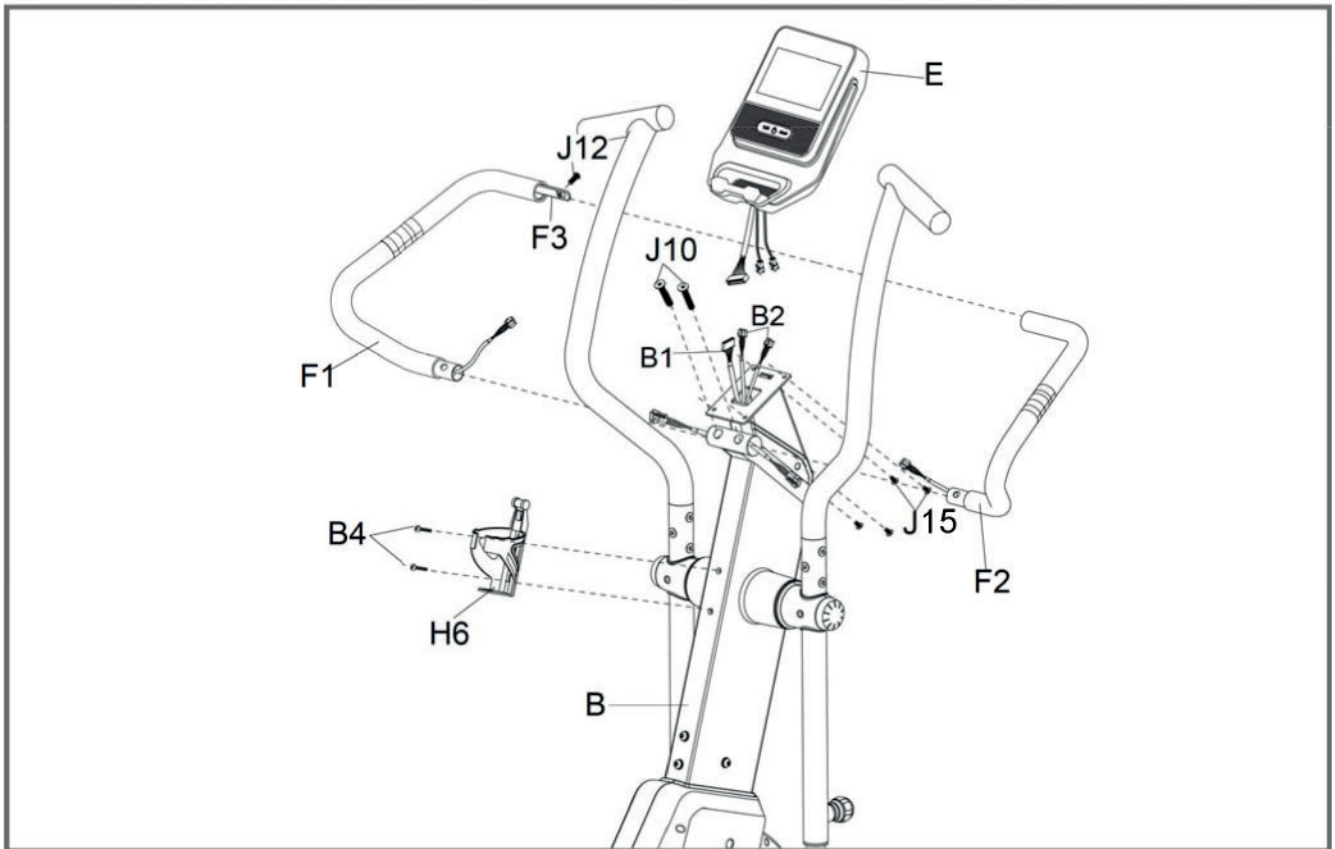

Step 8: Alignment of the Feet

If the floor is uneven, you can stabilize the equipment by turning the two setting caps on the rear stabilizer.

Step 9: Connecting the Equipment to the Mains Supply

► ATTENTION

The equipment must not be connected to a multiple socket, otherwise it cannot be guaranteed that the equipment will be supplied with sufficient power. Technical errors can result.

1. Plug the cable into the socket on the main frame.
2. Plug the power plug into a wall outlet that complies with the instructions in the chapter on electrical safety.

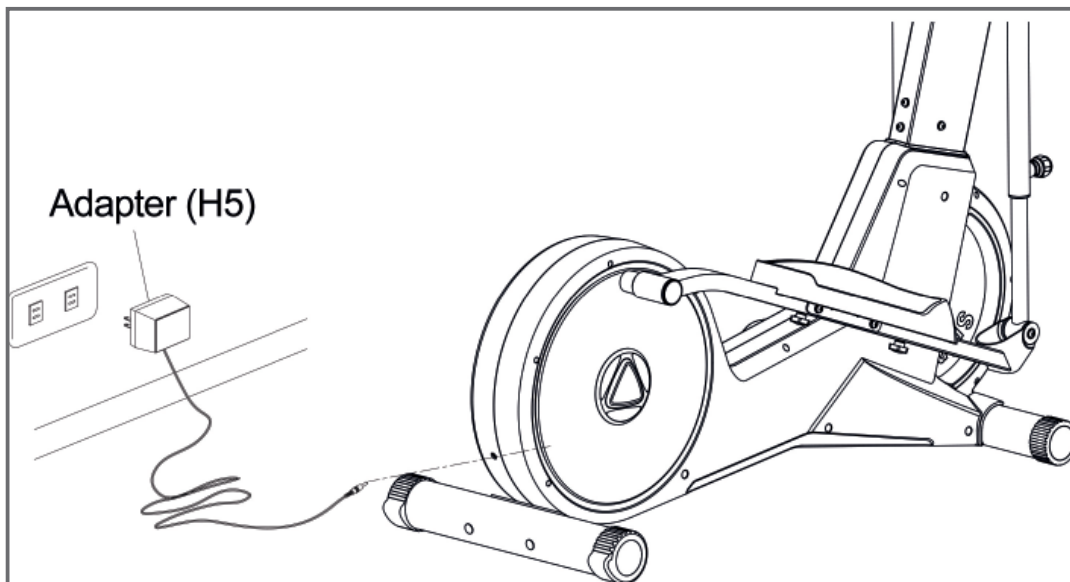

Correctly Getting On and Off

1. To get on, grip the handles with both hands and first step onto the left pedal with your left foot or onto the right pedal with your right foot and then place your foot onto the other pedal.
2. To get off, grip the handles with both hands and place one foot next to the equipment and then the other foot.

3 OPERATING INSTRUCTIONS

① NOTICE

- + Familiarise yourself with all the functions and setting options of the device before starting training. Have the proper use of this product explained to you by a specialist.
- + Always start your training with low intensity and increase evenly and gently. End your training with a cool-down phase. If you are unsure, please consult your physician.

3.1 Console Display



TIME	Display range: 0:00–99:59 Setting range: 0–99 (minutes)
SPEED	Display range: 0.0–99.9 (km/ml)
RPM	Display range: 0–999
CALORIES	Display range: 0–999 Setting range: 0–990
PULSE	Display range: 0–230 Setting range: 30–230
WATT	Display range: 0–999 Setting range: 10–400
LOAD	Display range: 1–16 Setting range: 1–16
DISTANCE	Display range: 0–99.9 Setting range: 0–99.0

3.2 Button Functions

QUICK START	<ul style="list-style-type: none"> + This button is used to switch on the console. + When the console is power saving mode, the Quick Start button can be used to activate the console + The Quick Start programme can be started with this key.
--------------------	---

3.3 Switching On and Initial Settings

1. Press the Quick Start button to turn on the console.

The main menu opens.

2. Tap on the time and date.
3. Turn on automatic time and date detection or select the appropriate time zone in which you are located.

ⓘ NOTICE

Make sure that the function for automatic time and date detection is switched off. If this function is switched on, it will light up turquoise.

4. Enter the time and date manually. To do this, first select a city in your time zone in the fourth row and, if necessary, set the time in the row above. Then set the current date in the second row.
5. Now connect the device to your Wi-Fi by returning to the settings and tapping Wi-Fi to connect to your network.

ⓘ NOTICE

If you receive the message "Connected, no Internet" although you are successfully connected to the Internet, this is no cause for concern. This is a translation issue and you should still be connected to the Internet. Then wait a few seconds until the message "This network has no Internet access. Stay connected?" appears, check the box "Don't ask again for this network" and confirm with "Yes".

6. You can now activate automatic time and date detection.
7. Finally, carry out an initial update for the console software.
8. Return to the settings.
9. Tap on "Software Update".
10. To update the software, tap on "Update" for TFT.

ⓘ NOTICE

- + The device must not be used or switched off during the update.
- + Check at regular intervals whether another update is available and perform it as described above.

Open the factory settings. Here you can set the following functions:

- + WIFI
- + Screen brightness
- + Volume
- + Language
- + Unit (metric or imperial)
- + Update software and app updates

► **ATTENTION**

The console of this fitness device uses software that is perfectly adapted to the equipment. Please do not make any unauthorised modifications, such as the installation of external apps. This can affect the functionality of the console or even make it unusable. Only install the necessary updates in the Software Updater.

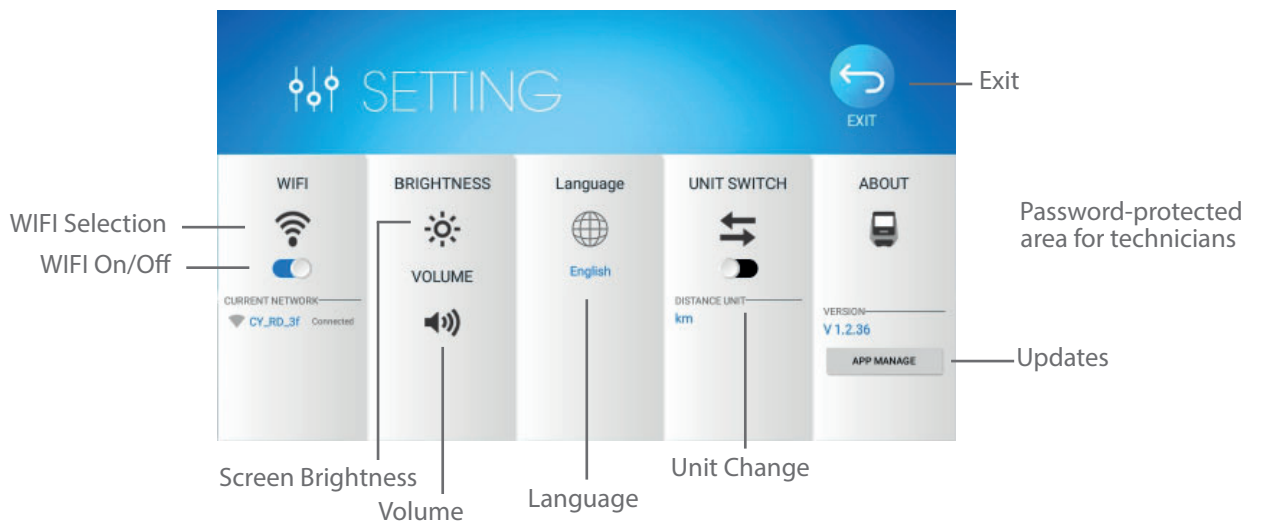
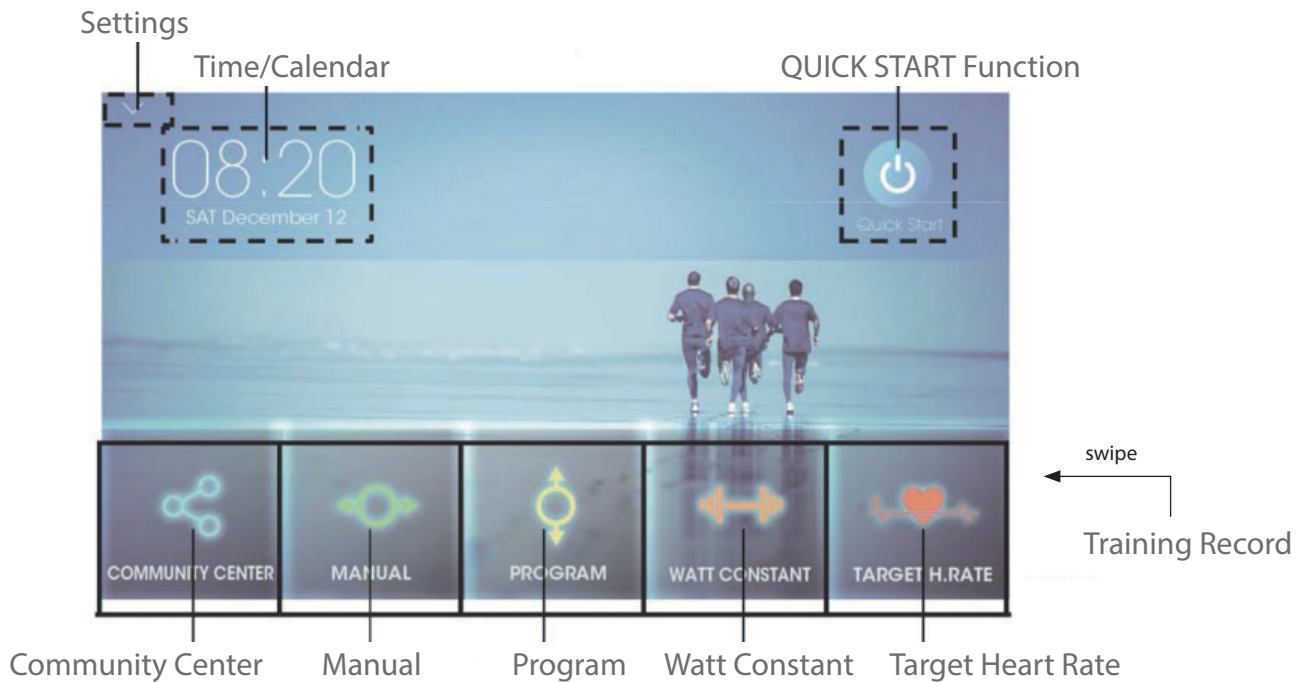

3.4 Programmes

There is a wide range of different programmes available. These include:

- + Quick Start Programme
- + Manual Programmes
- + Pre-set Programmes
- + Watt Programme
- + Heart Rate Controlled Programmes

① NOTICE

The user profile U0 acts as a guest profile. None of your training data is saved. If you use the guest profile U0, you must enter your data for age, height, weight and gender for each programme. The memory function is only available with the user profiles U1-U4. With the user profiles U1-U4, the set data is saved and must not be re-entered.

3.4.1 Quick-Start Programme

1. To start the quick-start programme, tap quick start in the main menu or press the quick start button.

The programme starts.

2. To increase or decrease resistance, tap the arrows.
3. To pause the programme, tap pause.
4. To resume the programme, tap continue.
5. To end the programme and return to the main menu, tap home.

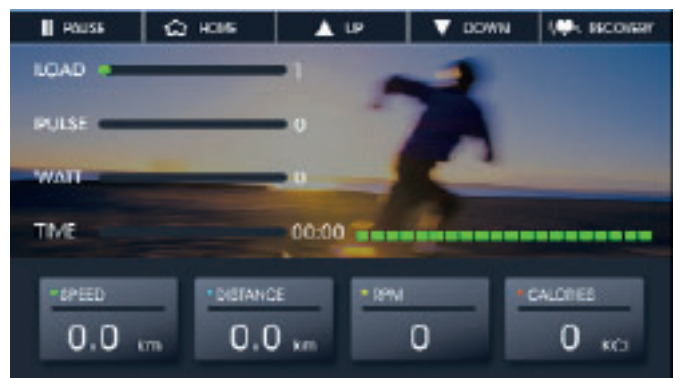

3.4.2 Manual Programme

There are several setting options for the manual programme. You can decide whether you want to train with one or more values.

1. To select the manual programme, tap “Manual” in the main menu.
2. Select one of the user profiles (U0–U4).
3. Set the desired values for time, distance and/or calories.
4. To start the programme, tap start.

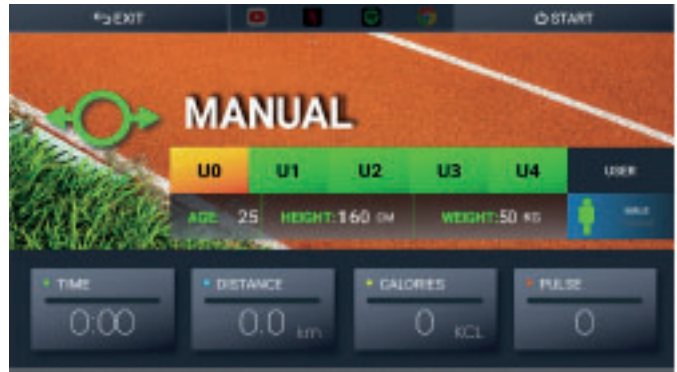

The programme starts. All set values will be counted down.

5. To increase or decrease resistance, tap the arrows.
6. To pause the programme, tap pause.
7. To resume the programme, tap continue.
8. To end the programm and return to the main menu, tap home.

3.4.3 Pre-Set Programmes

1. To select the profile programmes, tap “Program” in the main menu.
2. Select one of the user profiles (U0–U4).
3. Select one of the 60 profile programmes.
4. Set the desired training time.
5. To start the programme, tap start.

The programme starts.

6. To increase or decrease resistance, tap the arrows.
7. To pause the programme, tap pause.
8. To resume programme, tap continue.
9. To end the programme before the set training time has elapsed and return to the main menu, tap home.

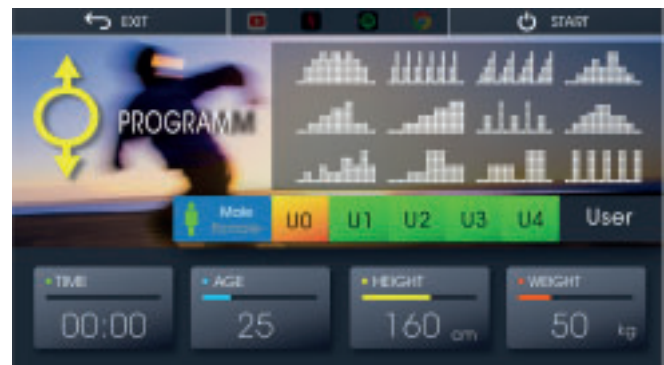

3.4.4 Watt Programme

1. To select the watt programme, tap “Watt constant” in the main menu.
2. Select one of the user profiles (U0–U4).
3. Set the desired training time and wattage.
4. To start the programme, tap start.

The programme starts. At the bottom of the screen it is displayed whether you should pedal faster or slower to maintain the set wattage.

5. To pause the programme, tap pause.
6. To resume the programme, tap continue.
7. To end the programme before the set training time has elapsed and return to the main menu, tap home.

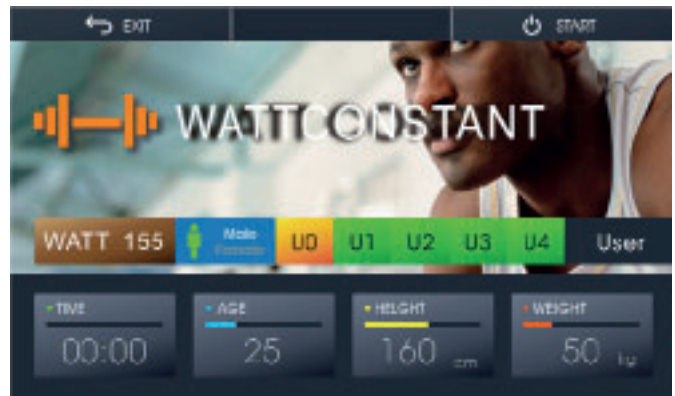

3.4.5 Heart Rate Controlled Programmes

WARNING

Your training equipment is not a medical device. The heart rate measurement of this equipment may be inaccurate. Various factors can affect the accuracy of the heart rate measurement. The heart rate measurement serves only as a training aid.

There are four heart rate programmes available. You can choose between three pre-set target heart rates (55%, 75% or 90% of your maximum heart rate) or TAG where you enter an individual target heart rate manually. Your maximum heart rate is determined by the console depending on your age. For these programmes we recommend using a compatible chest strap.

NOTICE

If you do not use a chest strap, your hands must be placed on the hand pulse sensors permanently during the workout.

1. To select the heart rate controlled programmes, tap “Target H. Rate” in the main menu.
2. Select one of the user profiles (U0–U4).
3. Select either 55%, 75%, 90% or TAG.
- 3.1. If you have selected TAG, now set your individual target value.
4. Set the desired training time.
5. To start the programme, tap start.



The programme starts.

6. To increase or decrease resistance, tap the arrows.
7. To pause the programme, tap pause.
8. To resume the programme, tap continue.

9. To end the programme before the set training time has elapsed and return to the main menu, tap home.

3.5 Recovery Function

After a completed workout, you can use the recovery function to test your recovery heart rate and thus your fitness level.

1. To test your recovery heart rate, tap recovery after training.
2. Grasp the hand pulse sensors with both hands.

After 60 seconds, your result will be displayed as a score (F1 –F6) where F1 is the best and F6 is the worst result.

Exercise regularly to improve your fitness and recovery heart rate.

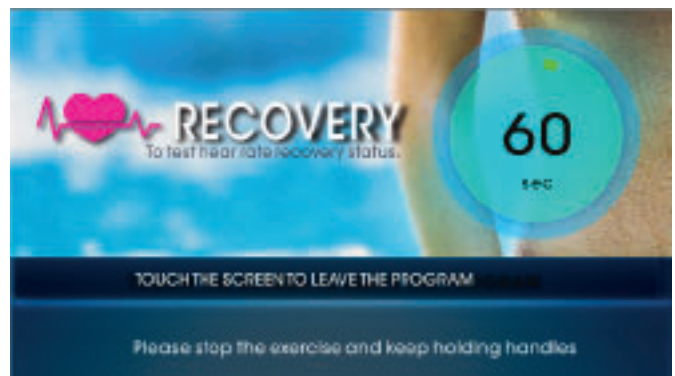

3.6 Training Record

The console offers you the possibility to use a training calendar and thus save your training sessions.

After the workout

When your training programme has finished, “workout” lights up in the display.

1. To save the training data in the training calendar, first tap “save” and then tap “home” to exit.
2. If you do not want to save the training data, tap “home” directly and return to the main menu.

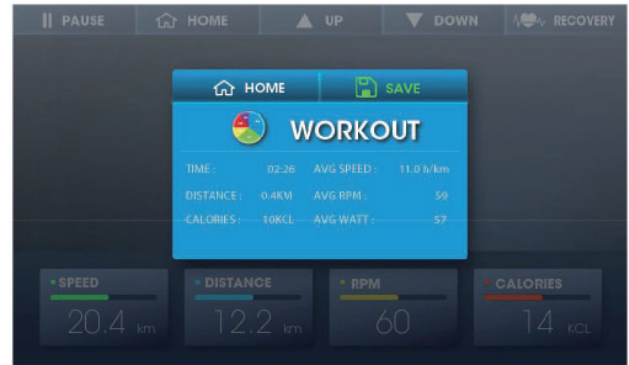

Viewing the training calendar

To view your saved training sessions in the training calendar, swipe left and then tap “Training Record” at the bottom right of the main menu. A calendar of the current month is displayed.

NOTICE

You can switch back and forth between the months by swiping your finger left and right.

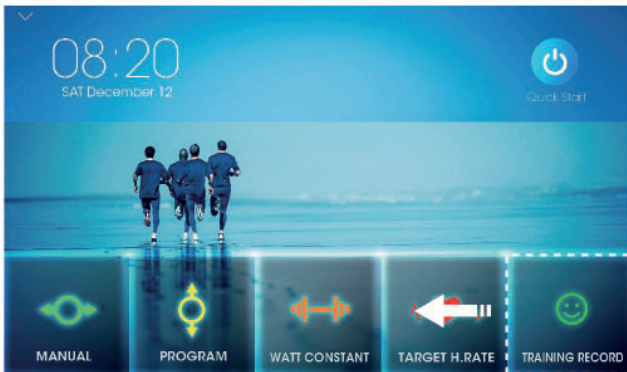

Where the calendar is coloured orange, a training session has been saved on that day. Tap on the corresponding day to view the more detailed training details. You can also delete the saved training data by tapping on the bin icon.



3.7 Multimedia and Software Updates

► ATTENTION

Check your TFT-console regularly for possible software updates. If available, make sure to carry out the updates soon. If the updates are not carried out over a longer period of time, this can lead to technical problems with the console.

To make sure the pre-installed apps are working correctly, they must be updated regularly as well. Follow the instructions on the screen to perform the updates.

Please note: The system is set up only for the pre-installed apps. Do not install any additional apps as their proper functionality can not be guaranteed. The installation of other apps might cause technical issues.

ⓘ NOTICE

- + The pre-installed apps are produced and provided by external manufacturers. Changes and availability within these apps might occur. Fitshop does not take any responsibility and can not be held liable for the availability, functionality or contents of these apps.
- + When the console is in MULTIMEDIA mode, it cannot enter power saving mode. If the console is not in use, please exit MULTIMEDIA mode and return to the main menu. Outside MULTIMEDIA mode, the console will enter power saving mode after 5 minutes.

In the media area you have access to various apps. These include:

- + YouTube
- + Netflix
- + Spotify
- + Chrome
- + iRoute
- + Kinomap

3.7.1 Retrieving Apps from the Main Menu

This way only the Quick-Start programme can be used

1. Tap Communication Centre in the Main Menu.
2. Select any app.
3. Tap the arrow on the left side of the screen.
4. Tap Quick Start and the programme starts.

3.7.2 Access to Apps During Your Workout

ⓘ NOTICE

The access to apps during the training is only possible within the manual programme or one of the profile programmes.

1. Start a desired programme.
2. To use an app during your workout, pause the programme for a moment and tap the desired app at the top of the screen.
3. Tap Continue and the app will open.

ⓘ NOTICE

It may take a moment for the app to open.

4. To continue your workout, tap the arrow on the left side of the screen and press the Quick Start button.

The selected app now runs simultaneously with the running programme.

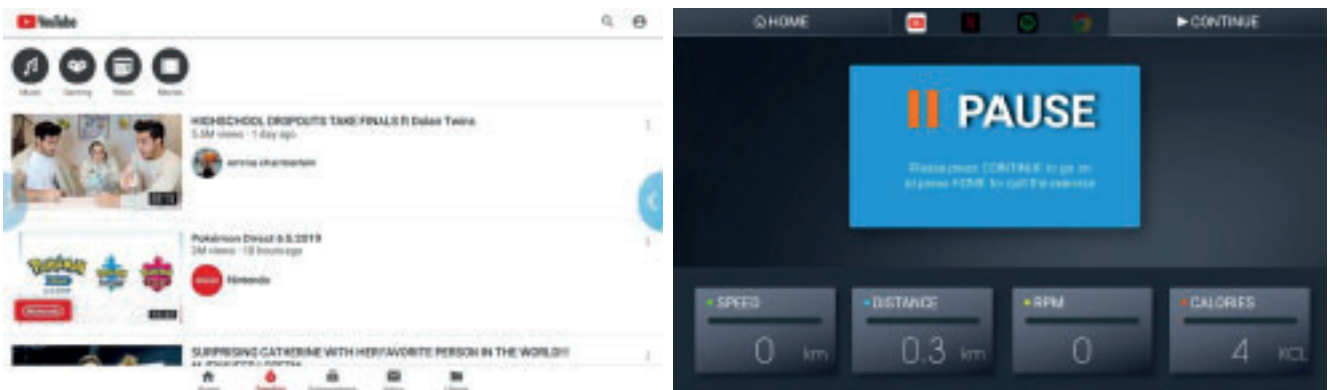

4.1 General Instructions

⚠ WARNING

- + The storage location should be chosen so that improper use by third parties or children can be prevented.
- + If your equipment does not have transportation wheels, the equipment must be disassembled before transportation.

▶ ATTENTION

- + Make sure that the equipment is protected from moisture, dust and dirt in the selected storage location. The storage location should be dry and well ventilated and have a constant ambient temperature between 10°C and 35°C.

4.2 Transportation Wheels

▶ ATTENTION

If you want to transport your equipment over particularly sensitive and soft floor coverings, such as parquet, planks or laminate, lay out the transport route with cardboard or similar to avoid possible floor damage.

1. Stand behind the equipment and lift it until the weight is transferred to the transportation wheels. After that, you easily can move the equipment to a new position. For long transport distances the equipment should be disassembled and safely packed.
2. Select the new location by following the instructions in the section 1.4 of this manual.

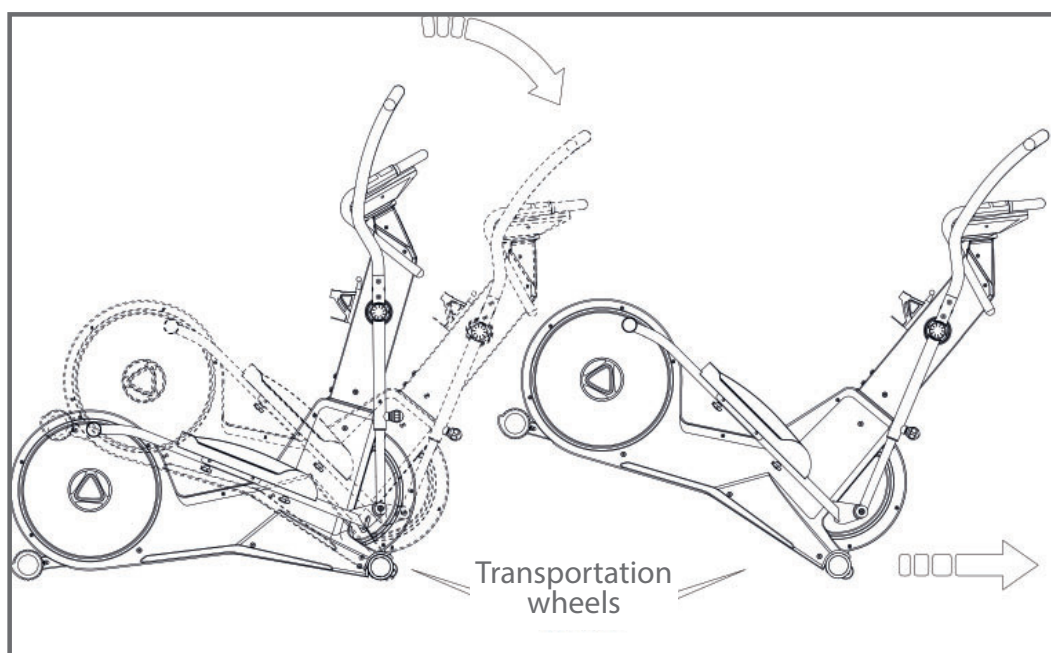

5.1 General Instructions



WARNING

- + Do not make any improper changes to the equipment.



CAUTION

- + Damaged or worn components may affect your safety and the life of the equipment. Therefore, immediately replace damaged or worn components. In such a case, contact the contract partner. The equipment must not be used until it has been repaired. If necessary, use only original spare parts.

▶ ATTENTION

- + In addition to the instructions and recommendations for maintenance and care given here, additional service and/or repair work may be necessary; this must only be carried out by authorised service technicians.

5.2 Faults and Fault Diagnosis

The equipment undergoes regular quality controls during production. Nevertheless, faults or malfunctions may occur. Frequently, individual parts are responsible for these disturbances, an exchange is usually sufficient. Please refer to the following overview for the most common errors and how to correct them. If the equipment still does not function properly, contact your contract partner.

Fault	Cause	Solution
Drive disks wobble/ make noises	Drive disk loose	Tighten nut (pay attention to left-hand / right-hand thread)
Display is blank/is not working	Loose cable connections	Check cable connections
Equipment wobbles	Equipment is not level	Align the feet
Creaking noises on the stepping area	Loose screws on stepping area	Tighten the screws on the stepping area
Creaking noises	Screw connections loosened or too tight	Check screw connections
Squeaking noises on the guide rails	Guide rails or rollers dirty or guide rails dry	Clean the guide rails and then lubricate them with a suitable lubricant

No pulse display	<ul style="list-style-type: none"> + Sources of interference in the room + unsuitable chest strap + Wrong position of chest strap + Chest strap defective or battery empty + Pulse display defective 	<ul style="list-style-type: none"> + Eliminate sources of interference (e.g. mobile phone, WLAN, lawn mower and vacuum cleaner robot, etc. ...) + Use a suitable chest strap (see RECOMMENDED ACCESSORIES). + Reposition chest strap and/or moisten electrodes + Changing batteries + Check if pulse display by hand pulse possible
------------------	---	--

5.4 Error Codes and Troubleshooting

The electronics of the equipment continuously carries out tests. In case of deviations, an error code appears on the display and normal operation is stopped for your safety.

Please contact the contract partner for technical support.

5.3 Maintenance and Inspection Calendar

To avoid damage from body sweat, the equipment must be cleaned with a damp towel (no solvents!) after each training session.

The following routine tasks must be performed at the specified intervals:

Part	Weekly	Monthly	Quarterly
Display console	C	I	
Slide rails*		C	
Lubrication of slide rails and moving parts*			I
Plastic covers	C	I	
Screws and cable connections		I	
Legend: C = clean; I = inspect			

*Make sure to always clean the slide rails and moving parts before re-lubricating.

By scanning the QR code with the camera function or QR code scanner app of your smartphone/tablet, a video on general maintenance of a crosstrainer opens on YouTube. The video serves to illustrate the maintenance points described in this manual.



Please note that the video may not be available in your language or with appropriate subtitles.

If you cannot scan QR codes, you can access all Fitshop videos on YouTube by first opening YouTube and entering "Fitshop" in the search field.

6 DISPOSAL

At the end of its operational life, this equipment cannot be disposed of in normal household waste. Instead, it must be disposed of via an electricals recycling centre. Further information can be obtained from your local authority's recycling service.



The materials can be recycled as per their symbols. Through the reuse, recycling of materials or other forms of recovery of old equipment, you make an important contribution to the protection of the environment.

7 RECOMMENDED ACCESSORIES

To make your training experience even more efficient and pleasant, we recommend that you add suiting accessories to your fitness equipment. For elliptical cross trainers this could for example be a **floor mat**, which makes your fitness equipment stand more securely and also protects the floor from sweat or **silicone spray** to keep moving parts in good shape.

If you have purchased a fitness machine with pulse training and want to train your heart rate, we strongly recommend that you use a compatible **chest strap**, as this ensures optimum transmission of the heart rate.

Our range of accessories offers the highest quality and makes training even better. If you would like to find out more about compatible accessories, please go to the detail page of the product in our webshop (the easiest way is to enter the article number in the search field above) and go to the recommended accessories on this page. Alternatively, you can use the QR code provided. Of course, you can also contact our customer service: by telephone, e-mail, in one of our branches or via our social media channels. We will be happy to advise you!



chest strap



floor mat



silicone spray



contact gel

8.1 Serial Number and Model Name

In order to provide you with the best possible service, please have the model name, article number, serial number, exploded drawing and parts list ready. The corresponding contact options can be found in chapter 10 of this operating manual.

NOTICE

The serial number of your equipment is unique. It's located on a white sticker. The exact position of this sticker is shown in the following illustration.



Enter the serial number in the appropriate field.

Serial number:

Brand / Category:

Model Name:

Article Number:

8.2 Parts List

No.	Name	Qty.	No.	Name	Qty.
A	MAIN FRAME	1	A35	WASHER	1
A1	SENSOR WIRE 1000mm	1	A36	NUT	2
A5	SENSOR WIRE HOUSING	1	A37	PLATE COVER	2
A6	SENSOR WIRE 900mm	1	A38	SCREW	6
A7	SCREW	2	A39	MAGNETIC HOUSING	1
A8	PULLEY	1	A40	SCREW	1
A9	MANGET $\Phi 15*7$	1	A41	NUT	1
A10	AXLE	1	A42	MAIN CHAIN COVER (L)	1
A11	SCREW	4	A43	MAIN CHAIN COVER (R)	1
A12	NUT	1	A44	SCREW	8
A13	NUT	4	A45	SCREW	12
A14	BEARING	2	A46	WASHER	1
A15	PRESSING PLARE	1	A47	NUT M8X7T	1
A16	SCREW	1	A49	BEARING 6000 2RS	1
A17	BEARING HOUSING	1	A50	EVA PAD STICKER 20*60*1.5T	6
A18	BEARING	2	A51	CLIP $\Phi 18.5*\Phi 22.5*1T$	1
A19	WASHER	1	A52	WASHER $\Phi 20.3*\Phi 30*0.5T$	1
A20	SCREW	1	A53	WAVE WASHER $\Phi 20.5*\Phi 30*0.3T$	1
A21	SPRING	1	A54	WAVE WASHER $\Phi 10.2*\Phi 13*0.3T$	2
A22	NUT	1	A55	FIXING SHEET	1
A23	SCREW	1	A60	MOTOR	1
A24	TURNING PLATE	2	A61	SCREW	2
A25	PIPE	2	A62	SCREW	1
A26	NUT	1	A63	NUT	1
A27	DECORATION COVER	2	A64	L-SHAPED BRACKET	1
A28	DC WIRE	1	A65	SCREW	1
A29	BELT	1	A66	L-SHAPED BRACKET	1
A30	MAGNETIC FLYWHEEL	1	A67	SCREW	2
A31	AXLE	1	B	CENTRAL SUPPORT TUBE	1
A32	BEARING	1	B1	SENSOR WIRE 850mm	1
A33	WASHER	3	B2	SENSOR WIRE 350mm	2
A34	BUSH	1	B3	END CAP	2

B4	SCREW	2	F4	HANDLE BAR SPONGE	2
B5	SCREW	2	F5	HANDLE BAR SPONGE	2
B6	END CAP	1	F8	SCREW	4
B7	END CAP	2	F10	HANDLE PLUSE SENSOR	2
B8	DECORATION COVER	2	F11	SENSOR HOUSING	2
B9	AXLE	1	F12	SENSOR WIRE 600mm	2
B11	BEARING	4	G1	SIDE HANDLE BAR (L)	1
B12	WASHER	2	G2	SIDE HANDLE BAR (R)	1
B13	SPRING WASHER	2	G3	KNOB	2
B14	SCREW	2	G4	SIDE HANDLE BAR SPONGE	2
B15	END CAP	2	H1	PEDAL (L)	1
B16	DECORATION COVER OF HANDLE BAR	2	H2	PEDAL (R)	1
B17	DECORATION COVER OF HANDLE BAR	2	H3	IRON BRACKET	2
			H4	KNOB	4
B18	SCREW	4	H5	ADAPTOR	1
B19	SWING HANDLE BAR TUBE	2	H6	BOTTLE HOLDER	1
B20	WAVE WASHER $\Phi 17.5*\Phi 25*0.3T$	2	H8	PEDAL TUBE (L)	1
B21	CENTRAL COVER (L)	1	H9	PEDAL TUBE (R)	1
B22	CENTRAL COVER (R)	1	H10	END CAP	2
C	REAR STABILIZER	1	H11	BEARING	2
C1	SCREW	2	H12	CLIP	2
C2	WASHER M8	2	H13	CONNECT TUBE	2
C3	SPRING WASHER M8	2	H14	BEARING	4
C4	NUT M8	2	H15	WASHER	2
C5	END CAP (L)	1	H16	SPRING WASHER	2
C6	END CAP (R)	1	H17	BUSH	2
D	FRONT STABILIZER	1	H18	AXLE	2
D1	END CAP	2	H19	SCREW	2
D2	WHEEL	2	H20	WASHER	2
D3	SCREW	4	H21	SPRING WASHER	2
E	CONSOLE	1	H22	SCREW	2
F1	HANDLE BAR (L)	1	J1	SCREW M8*90mm	2
F2	HANDLE BAR (R)	1	J2	SPRING WASHER M8	10
F3	IRON BRACKET	1	J3	WASHER M8	10

J4	SCREW M8*20mm	6
J5	SCREW M8	6
J6	SCREW M8*28mm	6
J7	SCREW	4
J9	WASHER M6	4
J10	SCREW M8*45mm	2
J11	SPRING WASHER M6	4
J12	SCREW M6*16mm	2
J13	SPRING WASHER M10	2
J14	WASHER M10	2
J15	SCREW	4

8.3 Exploded Drawing

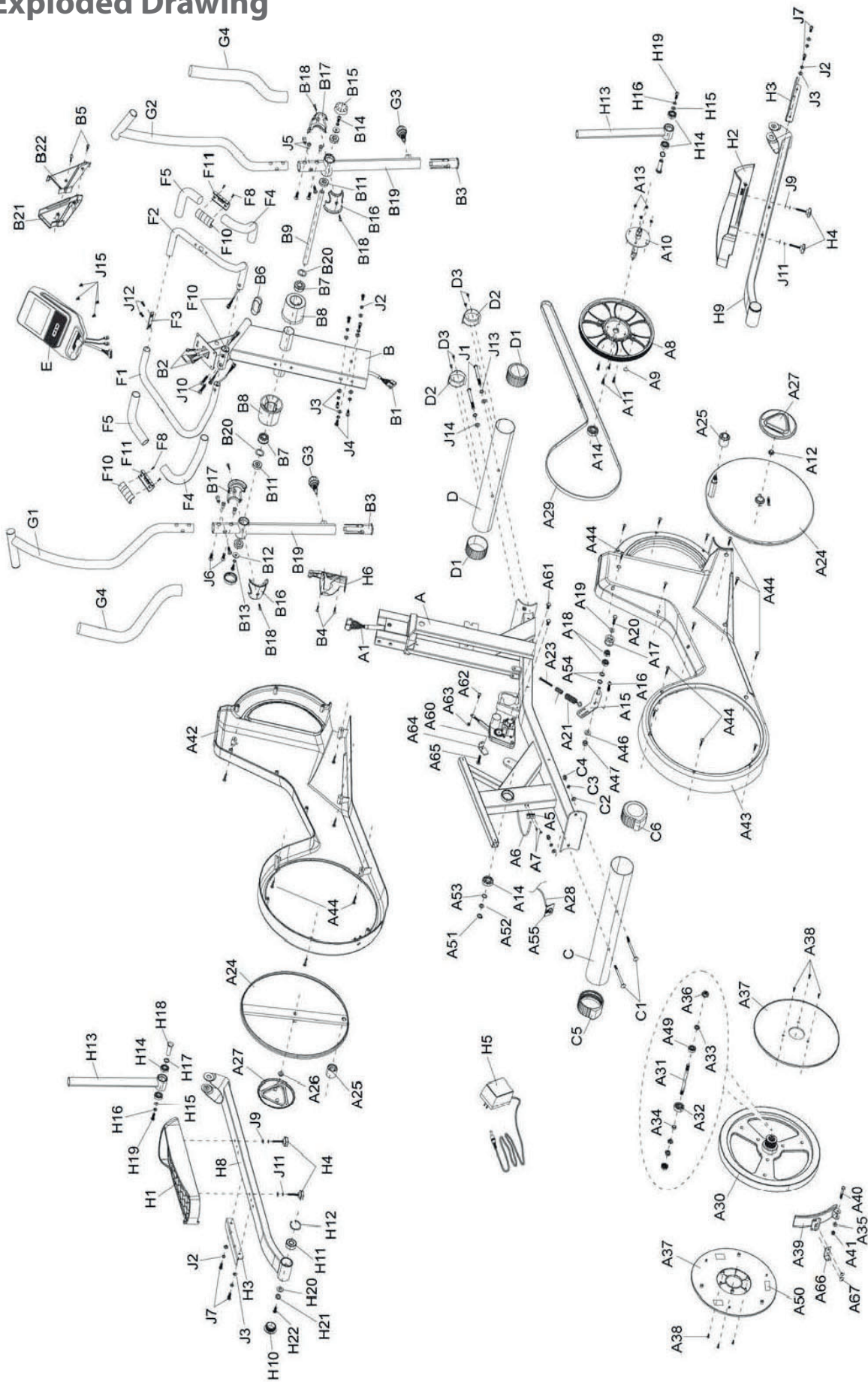

Products from cardiostrong® are subject to strict quality control. However, if a fitness equipment purchased from us does not work perfectly, we take it very seriously and ask you to contact our customer service as indicated. We are happy to help you by phone via our service hotline.

Error Descriptions

Your fitness equipment is developed for long-term, high-quality training. However, should a problem arise, please first read the operating instructions. For further assistance, please contact your contract partner or call our service hotline. To ensure your problem is solved as quickly as possible, please describe the defect as exactly as possible.

In addition to the statutory warranty, we provide a warranty for every fitness equipment purchased from us according to the following provisions.

Your statutory rights are not affected.

Warrantee

The warrantee is the first/original buyer and/or any person who received a newly purchased product as a gift from the original buyer.

Warranty period

The warranty periods, shown on our web shop, begin on delivery of the fitness equipment. The respective warranty periods for your equipment can be found on its product website.

Repair Costs

According to our choice, there will either be a repair, a replacement of individual damaged parts or a complete replacement. Spare parts, that have to be mounted while assembling the equipment, have to be replaced by the warrantee personally and are not a part of repair. After the expiration of the warranty period, the responsibility for parts costs, repair costs, installation costs and delivery costs lies with the warranty holder.

The terms of use are defined as follows:

- + Home use: solely for private use in private households up to 3 hours per day
- + Semi-professional use: up to 6 hours per day (e. g. rehabilitation centres, hotels, clubs, company gyms)
- + Professional use: more than 6 hours per day (e. g. commercial gyms)

Warranty Service

Within the warranty period, equipment which develops faults as a result of material or manufacturing defects, will be repaired or replaced at our discretion. Ownership of equipment or parts of equipment which have been replaced is transferred to us. The warranty period is not extended nor does a new warranty period begin following repair or replacement under the warranty.

Warranty Conditions

For the warranty to be valid, the following steps must be taken:

Please contact our customer service by email or phone. If the product under warranty has to be sent in for repair, the seller bears costs. After expiry of the warranty, the buyer bears the costs of transport and insurance. If the fault is covered by our warranty, you will receive a new or repaired equipment in return.

Warranty claims are invalid in case of damage resulting from:

- + misuse or improper handling
- + environmental influences (moisture, heat, electrical surge, dust, etc.)
- + failure to follow the current safety measures for the equipment
- + failure to follow the operating instructions
- + use of force (e. g. hitting, kicking, falling)
- + interventions which were not carried out by one of our authorized service centres
- + unauthorised repair attempts

Proof of Purchase and Serial Number

Please make sure that you are able to provide the appropriate receipt when claiming on your warranty. So that we can clearly identify the model of your equipment, and for the purposes of our quality control, you will need to give the serial number of your equipment, when contacting the service team. Where possible please have your serial number and your customer number ready when you call our service hotline. It will help us to deal with your request swiftly.

If you cannot find the serial number on your fitness equipment, our service team is at your disposal to offer further information.

































Service outside of the Warranty Period

We are also happy to issue an individual cost estimate if there is a problem with your fitness equipment after the warranty has expired, or in cases which do not fall under the terms of the warranty, e. g. normal wear and tear. Please contact our customer service team to find a quick and cost-effective solution to your problem. In such a case you will be responsible for the delivery costs.

Communication

Many problems can be solved just by speaking to us as your specialist supplier. We know how important it is to you as a user of the fitness equipment to have problems solved quickly and simply, so you can enjoy working out with minimal interruption. For that reason, we also want to resolve your queries quickly and in a straightforward manner. Thus, please always keep your customer number and the serial number of the faulty equipment handy.

10 CONTACT

DE	DK	UK
<p>TECHNIK</p> <p> +49 4621 4210-900</p> <p> +49 4621 4210-698</p> <p> technik@fitshop.de</p> <p> Öffnungszeiten entnehmen Sie unserer Homepage.</p>	<p>TEKNIK OG SERVICE</p> <p> 80 90 16 50</p> <p>+49 4621 4210-945</p> <p> info@fitshop.dk</p> <p> Åbningstider kan findes på hjemmesiden: https://stg.fit/statit7</p>	<p>CUSTOMER SUPPORT</p> <p> 00800 2020 2772</p> <p>+494621 4210 944</p> <p> info@fitshop.co.uk</p> <p> You can find the opening hours on our homepage: https://stg.fit/statitc</p>
<p>SERVICE</p> <p> 0800 20 20277 (kostenlos)</p> <p> 04621 4210 - 0</p> <p> info@fitshop.de</p> <p> Öffnungszeiten entnehmen Sie unserer Homepage: https://stg.fit/statita</p>	<p>FR</p> <p>TECHNIQUE & SERVICE</p> <p> +33 (0) 189 530984</p> <p>+49 4621 42 10 933</p> <p> info@fitshop.fr</p> <p> Vous trouverez les heures d'ouverture sur notre site Internet: https://stg.fit/statit4</p>	<p>BE</p> <p>TECHNIQUE & SERVICE</p> <p> 02 732 46 77</p> <p>+49 4621 4210 933</p> <p> info@fitshop.be</p> <p> Vous trouverez les heures d'ouverture sur notre site Internet: https://stg.fit/statit8</p>
<p>ES</p> <p>TECNOLOGÍA Y SERVICIOS</p> <p> 911 238 029</p> <p> info@fitshop.es</p> <p> Consulta nuestro horario de apertura en la página web: https://stg.fit/statit5</p>	<p>NL</p> <p>TECHNISCHE DIENST & SERVICE</p> <p> +31 172 619961</p> <p> service@fitshop.nl</p> <p> De openingstijden vindt u op onze homepage: https://stg.fit/statit3</p>	<p>INT</p> <p>TECHNICAL SUPPORT & SERVICE</p> <p> +49 4621 4210-944</p> <p> service-int@fitshop.de</p> <p> You can find the opening hours on our homepage: https://stg.fit/statita</p>
<p>PL</p> <p>DZIAŁ TECHNICZNY I SERWIS</p> <p> 22 307 43 21</p> <p>+49 4621 42 10-948</p> <p> info@fitshop.pl</p> <p> Godziny otwarcia można znaleźć na stronie głównej: https://stg.fit/statit6</p>	<p>AT</p> <p>TECHNIK & SERVICE</p> <p> 0800 20 20277 (Freecall)</p> <p>+49 4621 42 10-0</p> <p> info@fitshop.at</p> <p> Öffnungszeiten entnehmen Sie unserer Homepage: https://stg.fit/statitb</p>	<p>CH</p> <p>TECHNIK & SERVICE</p> <p> 0800 202 027</p> <p>+49 4621 42 10-0</p> <p> info@fitshop.ch</p> <p> Öffnungszeiten entnehmen Sie unserer Homepage: https://stg.fit/statit9</p>

Please find a detailed overview including address and opening hours for all stores of the Fitshop Group in Germany and abroad on the following website:

www.fitshop.com/en/stores

WE LIVE FITNESS

WEBSHOP AND SOCIAL MEDIA

Fitshop is Europe's largest specialist store for home fitness equipment with currently over 70 stores and one of the world's most renowned online mail order companies for fitness equipment. Private customers order via the 25 web shops in the respective national language or have their desired equipment assembled on site. In addition, the company supplies fitness studios, hotels, sports clubs, companies and physio practices with professional equipment for endurance and strength training.

Fitshop offers a wide range of fitness equipment from renowned manufacturers, high-quality in-house developments and comprehensive services, such as a build-up service and sports scientific advice before and after the purchase. The company employs numerous sports scientists, fitness trainers and competitive athletes.

Visit us also on our social media platforms or our blog!

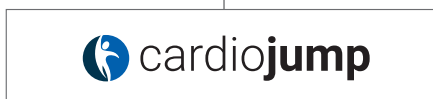
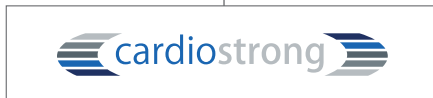
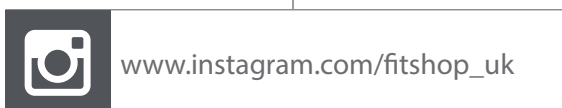

Notes

Notes

