



Assembly and Operating Instructions



max. 160 kg



~ 45 Min. 



 125 kg
L 205 | W 90 | H 145

CSTTX90.02.10

Art. No. CST-TX90-2

Treadmill **TX90**

Content

1	GENERAL INFORMATION	7
1.1	Technical Data	7
1.2	Personal Safety	8
1.3	Electrical Safety	9
1.4	Set-Up Place	10
2	ASSEMBLY	11
2.1	General Instructions	11
2.2	Scope of Delivery	12
2.3	Assembly	14
3	OPERATING INSTRUCTIONS	18
3.1	Console Display	19
3.2	Button Functions	20
3.3	Training programmes	21
3.3.1	Quick Start	21
3.3.2	Target programmes	21
3.3.3	Pre-set programmes	22
3.3.4	User-defined programmes	25
3.4	Heart Rate Oriented Programmes	26
3.5	Fitness test	27
3.6	Media	28
4	STORAGE AND TRANSPORT	29
4.1	General Instructions	29
4.2	Transportation Wheels	29
4.3	Folding Mechanism	29
4.3.1	Folding Up the Treadmill	30
4.3.2	Unfolding the Treadmill	30
5	TROUBLESHOOTING, CARE AND MAINTENANCE	31
5.1	General Instructions	31
5.2	Faults and Fault Diagnosis	31
5.3	Care and Maintenance	32
5.3.1	Adjusting the Running Mat	32
5.3.2	Re-tensioning the Running Mat	33
5.3.3	Lubricating the Running Mat	33
5.4	Maintenance and Inspection Calendar	34
6	DISPOSAL	34

7	RECOMMENDED ACCESSORIES	35
8	ORDERING SPARE PARTS	36
8.1	Serial Number and Model Name	36
8.2	Parts List	37
8.3	Exploded Drawing	42
9	WARRANTY	43
10	CONTACT	45

Dear customer,

Thank you for choosing a high-quality equipment of the brand cardiostrong®. cardiostrong® offers sports and fitness equipment for the sophisticated home sport and the equipment of fitness studios and business customers. With cardiostrong® fitness equipment, the focus is on what sport is all about: maximum performance! Therefore, the equipment is developed in close consultation with athletes and sports scientists. Because athletes know best what makes perfect fitness equipment.

Further information can be found at www.sport-tiedje.com.

Intended Use

The equipment may only be used for its intended purpose.

The equipment is only suitable for home use. The equipment is not suitable for semi-professional (e.g. hospitals, associations, hotels, schools, etc.) and commercial or professional use (e.g. fitness studios).

Legal Notice

Sport-Tiedje GmbH
Europe's No. 1 for home fitness

International Headquarters
Flensburger Straße 55
24837 Schleswig
Germany

Management:
Christian Grau
Sebastian Campmann
Dr. Bernhard Schenkel
No. HRB 1000 SL
Local Court Flensburg
European VAT Number: DE813211547

Disclaimer



©2010 cardiostrong® is a registered brand of the company SportTiedje GmbH. All rights reserved. Any use of this trademark without the explicit written permission of Sport-Tiedje is prohibited.

Product and manual are subject to change. Technical data can be changed without advance notice.

ABOUT THIS MANUAL

Please carefully read the entire manual before installation and first use. The manual will help you to quickly set up the system and explains how to safely use it. Make sure that all persons exercising with the equipment (especially children and persons with physical, sensory, mental or motor disabilities) are informed about this manual and its contents in advance. In case of doubt, responsible persons must supervise the use of the equipment.

Due to ongoing changes and software optimisations, the manual may have to be updated. If you notice any discrepancies during assembly or use, please refer to the manual uploaded to the webshop. The latest manual is always available there.

This equipment has been manufactured according to the latest safety knowledge. As far as possible, potential safety hazards which could cause injury have been eliminated. Make sure to carefully follow the instructions and that all parts are securely in place. If required, read through the instructions again to correct any mistakes.



Please pay close attention to the safety and maintenance instructions given here. The contract partner cannot be held liable for damage to health, accidents or damage to the equipment when it is not used in accordance with these instructions.

The following safety instructions may appear in this manual:

► **ATTENTION**

This notice indicates potentially hazardous situations which, if not avoided, may result in property damage.

⚠ **CAUTION**

This notice indicates potentially hazardous situations which, if not avoided, may result in slight or minor injuries!

⚠ **WARNING**

This notice indicates potentially hazardous situations which, if not avoided, may result in death or serious injuries!

⚠ **DANGER**

This notice indicates potentially hazardous situations which, if not avoided, will result in death or serious injuries!

ⓘ **NOTICE**

This notice indicates further useful information.

Retain these instructions in a safe place for future reference, maintenance or when ordering replacement parts.

1.1 Technical Data

TFT display of

- + speed in km/h
- + training time in min
- + training distance in km
- + calories burnt in kcal
- + heart rate (when using the hand sensors or a chest strap)
- + incline in %

Motor output:	3.5 HP continuous output (DC motor)
Speed range:	0.8 - 20 km/h
Speed hot keys:	8
Incline range:	0 - 15 %
Incline hot keys:	8

Total number of training programmes:	45
Quick start:	1
Pre-set programmes:	32
Target programmes:	3
User-defined programmes:	4
Heart rate-oriented programmes:	3

Running surface size (L x W):	152 cm x 52 cm
-------------------------------	----------------

Weight and dimensions:

Article weight (gross, including packaging):	145 kg
Article weight (net, without packaging):	125 kg

Packaging dimensions (L x W x H):	213 cm x 98 cm x 45 cm
Set-up dimensions (L x W x H):	205 cm x 89.5 cm x 144.5 cm

Maximum user weight:	160 kg
----------------------	--------

1.2 Personal Safety

DANGER

- + Before you start using the equipment, you should consult your physician that this type of exercise is suitable for you from a health perspective. Particularly affected are persons who: have a hereditary disposition to high blood pressure or heart disease, are over the age of 45, smoke, have high cholesterol values, are overweight and/or have not exercised regularly in the past year. If you are under medical treatment that affects your heart rate, medical advice is absolutely essential.
- + Note that excessive training can seriously endanger your health. Please also note that heart rate monitoring systems can be inaccurate. If you notice any signs of weakness, nausea, dizziness, pain, shortness of breath, or other abnormal symptoms, stop exercising immediately and seek advice from your doctor if necessary.

WARNING

- + This equipment may not be used by children under the age of 14.
- + Children should not be allowed unsupervised access to the equipment.
- + Persons with disabilities must have a medical license and must be under strict observation when using the equipment.
- + The equipment is strictly for use by one person at a time.
- + If your equipment provides a safety key, the clip of the safety key must be attached to your clothing before starting your training. In the event of a fall, the EMERGENCY STOP of the equipment can be initiated.
- + Keep your hands, feet and other body parts, hair, clothing, jewellery and other objects well clear of moving parts.
- + During use, wear suitable sports clothing rather than loose or baggy clothing. When wearing sports shoes, make sure they have suitable soles, preferably made of rubber or other non-slip materials. Shoes with heels, leather soles, studs or spikes are unsuitable. Never exercise barefoot.

CAUTION

- + If your equipment needs to be connected to the power supply with a mains cable, make sure that the cable is not a potential tripping hazard.
- + Make sure that nobody is within the range of motion of the equipment during training so as not to endanger you or other persons.

ATTENTION

- + Do not insert any objects of any kind into the openings of the device.

1.3 Electrical Safety

DANGER

- + In order to reduce the risk of an electric shock, always unplug the equipment from the mains socket immediately after your workout, before assembly or dismantling, and before maintenance or cleaning. Do not pull on the cable.

WARNING

- + Do not leave the equipment unattended while the mains cable is plugged into the mains socket. During your absence, the mains cable must be removed to prevent improper use by third parties or children.
- + If the mains cable or plug is damaged or defective, contact your contract partner. In the meantime, the equipment must not be used.

ATTENTION

- + The equipment requires a mains connection of 220-230V with 50 Hertz mains voltage.
- + The equipment may only be connected directly to an earthed socket using the supplied mains cable. Extension cables must conform to VDE guidelines. Always completely unwind the mains cable.
- + The socket must be protected by a fuse with a minimum fuse rating of "16 amps, slow blow".
- + Do not make any changes to the mains cable or the mains plug.
- + Keep the mains cable away from water, heat, oil and sharp edges. Do not route the mains cable underneath the equipment or under a carpet or rug, and do not place any objects on top of it.
- + If your purchased item is equipped with a TFT console, software updates must be carried out regularly. Follow the instructions on the console to perform the update(s).
- + The software systems on gym equipment with TFT consoles are set up only for the pre-installed apps. Do not install any additional apps.

NOTICE

- + The pre-installed apps on TFT consoles are produced and provided by external manufacturers. Sport-Tiedje does not take any responsibility for the availability, functionality or contents of these apps.

1.4 Set-Up Place



WARNING

- + Do not place the equipment in main corridors or escape routes.



CAUTION

- + The training room should be well ventilated during training and not be exposed to any draughts.
- + Choose the place in which to set up the equipment such that there is enough free space/clearance to the front, the rear and to the sides of the equipment.
- + The set-up and mounting surface of the equipment should be flat, loadable and solid.

ATTENTION

- + The device may only be used in one building, in sufficiently tempered and dry rooms (ambient temperatures between 10°C and 35°C). The equipment should not be used outdoors or in rooms with high humidity (over 70%) like swimming pools.
- + A floor protective mat/equipment underlay can help to protect high-quality floor coverings (parquet, laminate, cork, carpets) from dents and sweat and can help to level out slight unevenness.

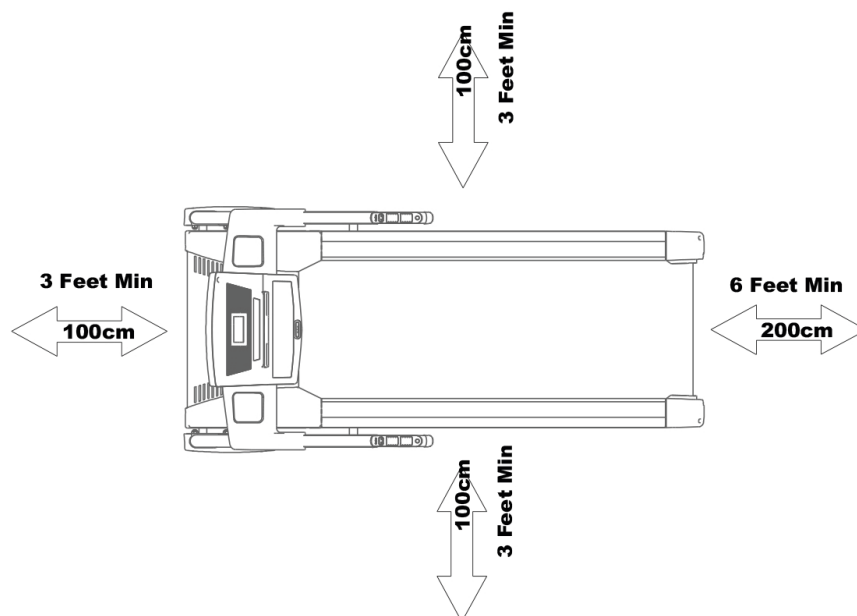

2.1 General Instructions



DANGER

- + Do not leave any tools, packaging materials such as foils or small parts lying around, as otherwise there is a danger of suffocation for children. Keep children away from the equipment during assembly.



WARNING

- + The treadmill is equipped with high-pressure shock absorbers that can cause the treadmill to suddenly open if handled incorrectly. To avoid possible personal injuries, never pull on the areas of the treadmill shown in the illustration. Never try to lift or move the treadmill at the marked areas.
- + Pay attention to the instructions attached to the equipment in order to reduce the risk of injuries.

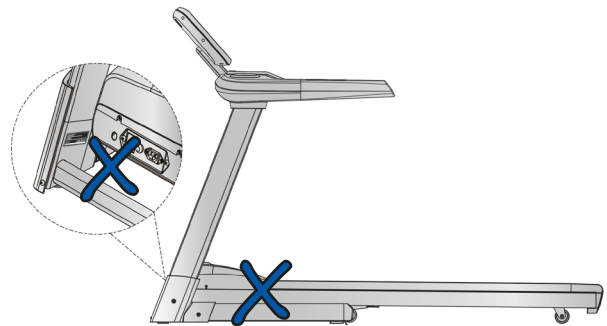

CAUTION

- + Do not open the packaging when it is lying on its side.
- + Ensure to have sufficient room for movement in each direction during assembly.
- + The assembly of the equipment must be carried out by at least two adults. If in doubt, seek the help of another technically skilled person.



ATTENTION

- + To prevent damage to the equipment and the floor, assemble the equipment on a mat or packaging board.



NOTICE

- + In order to make the assembly as simple as possible, some screws and nuts to be used can already be pre-assembled.
- + Ideally, assemble the equipment at its later set-up place.

2.2 Scope of Delivery



WARNING

Around the treadmill there is a strap that prevents the treadmill from opening during transport. This strap must be removed before assembly.

The scope of delivery consist of the following parts. At the beginning, check whether all parts and tools belonging to the device are included in the scope of delivery and whether damage has occurred. In the event of complaints, the contractual partner must be contacted directly.



CAUTION

If parts of the scope of delivery are missing or damaged, the assembly must not be carried out.

1

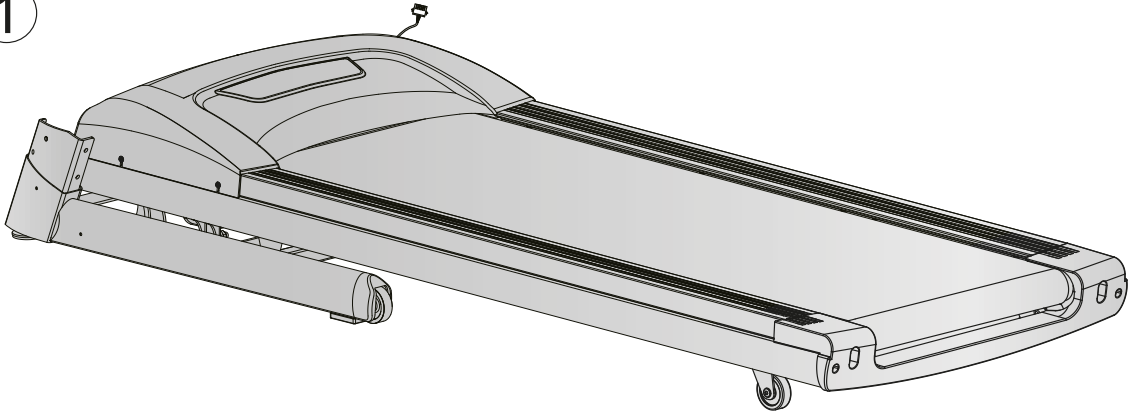

x1

4

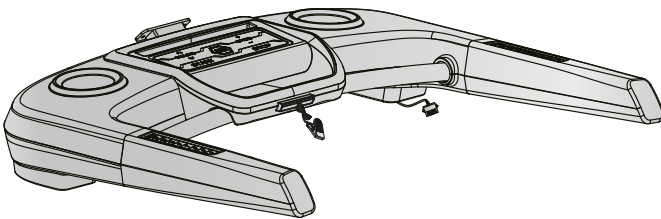

x1

2

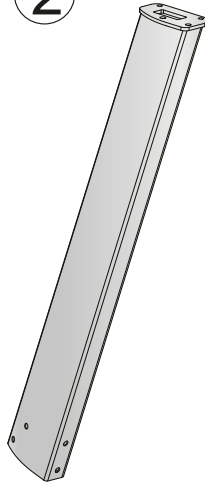

x1

3

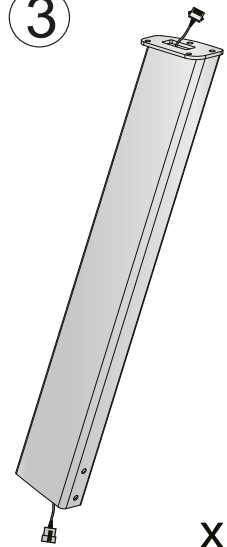

x1

52L

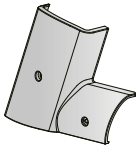

x1

52R

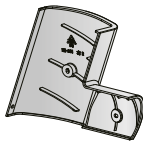

x1

111

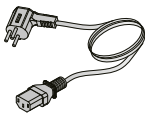

x1

89A



89B



x1

88



x1

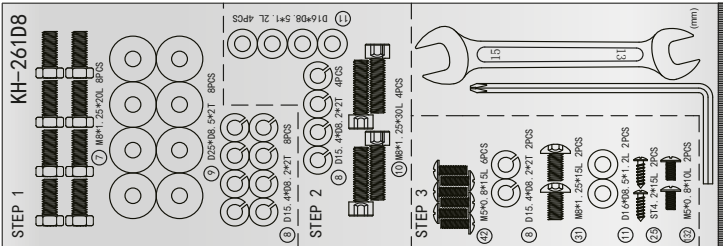

2.3 Assembly

Before assembly, take a close look at the individual assembly steps shown and carry out the assembly in the order given.

① NOTICE

- + First loosely screw all parts together and check that they fit properly. Tighten the screws using the tool only when you are instructed to do so.
- + If you have difficulty recognising the graphics, we recommend that you open and/or download the PDF instructions stored in the webshop on your end device (e.g. smartphone, tablet or PC). There you have the option of zooming in closer. Please note that the Adobe Acrobat Reader programme must be installed on your end device in order to open the file.

Step 1: Assembly of the console masts

1. Connect the two cables (115 and 116) with one another.

▶ ATTENTION

Be careful not to pinch the cables in the following step.

2. Fix the right and left handlebar post (2 and 3) to the main frame (1) with eight allen bolts (7), eight spring washers (8) and eight flat washers (9).

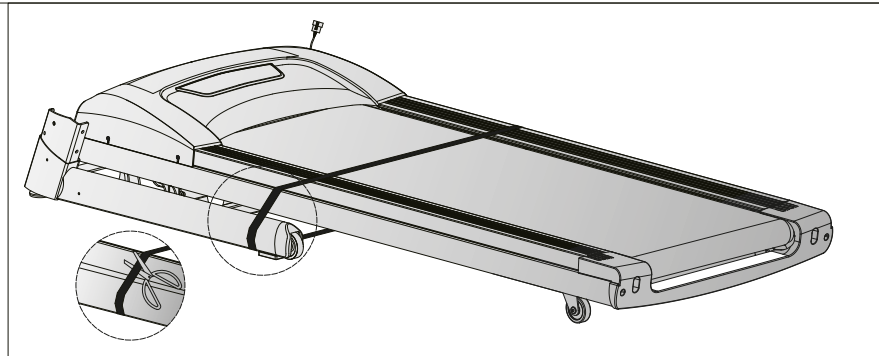
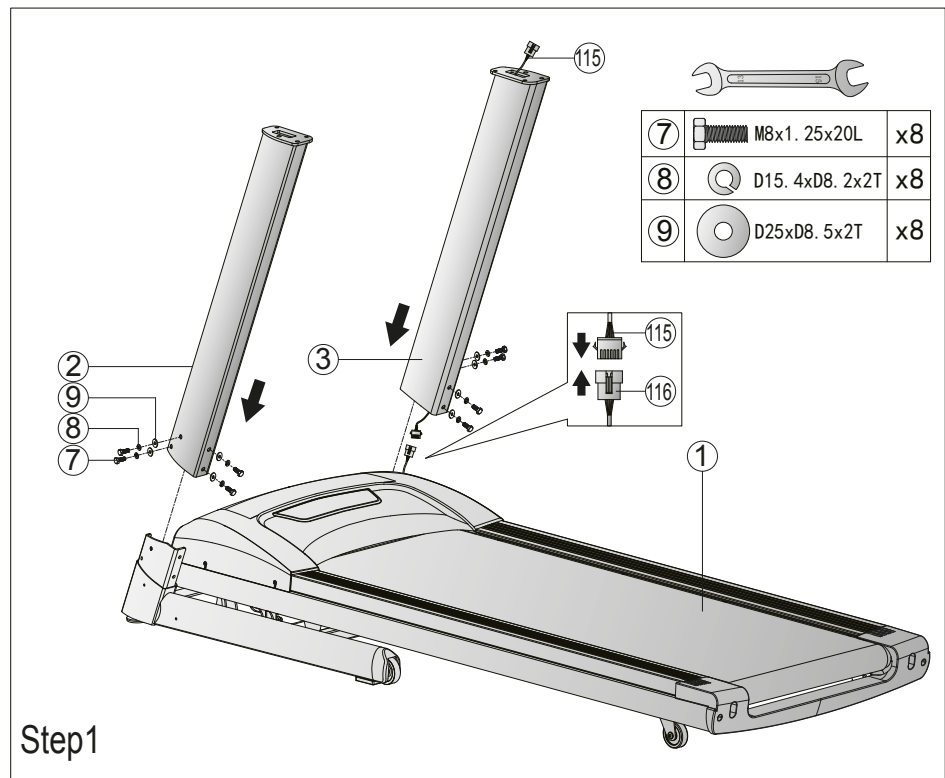

Step 2: Assembly of the console unit

1. Connect the two cables (114 and 115) with one another.

► **ATTENTION**

Be careful not to pinch the cables in the following step.

2. Fix the handlebar (4) to the handlebar posts (2 and 3) with four allen screws (10), four spring washers (8) and four flat washers (11).

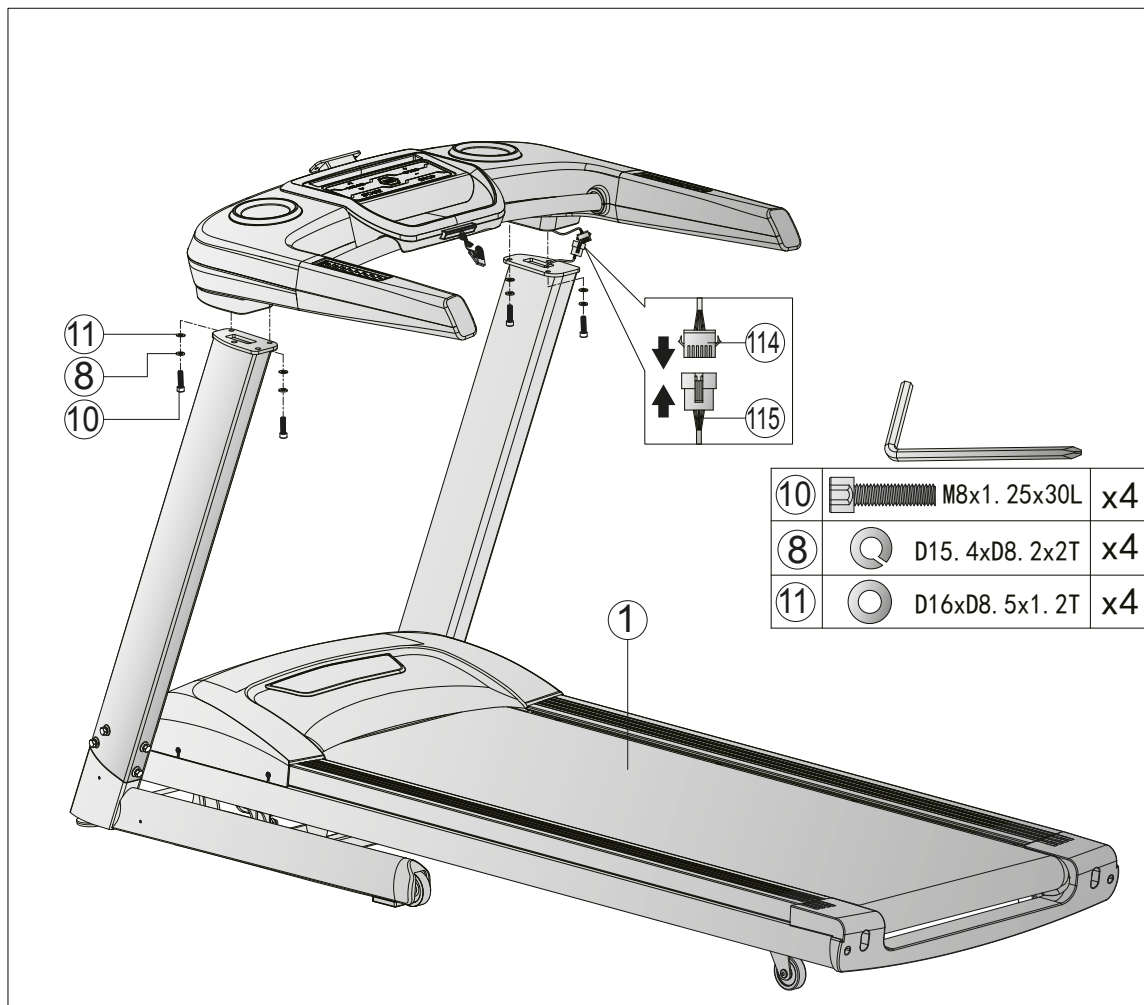

Step 3: Assembly of the console

1. Connect the cables (92, 93, 110 and 114) with their counterparts of the console (88).

► **ATTENTION**

Be careful not to pinch the cables in the following step.

2. Fix the console (88) to the handlebar (4) with two allen bolts (31), two flat washers (11) and two spring washers (8).
3. Fix the console cover (89B) to the console (88) with two cross bolts (132).
4. Attach the decorative cover (89A) with two screws (25).
5. Now tighten the bolts (7) from **step 1**.
6. Attach the two covers for the handlebar post (52L and 52R) with six bolts (42).

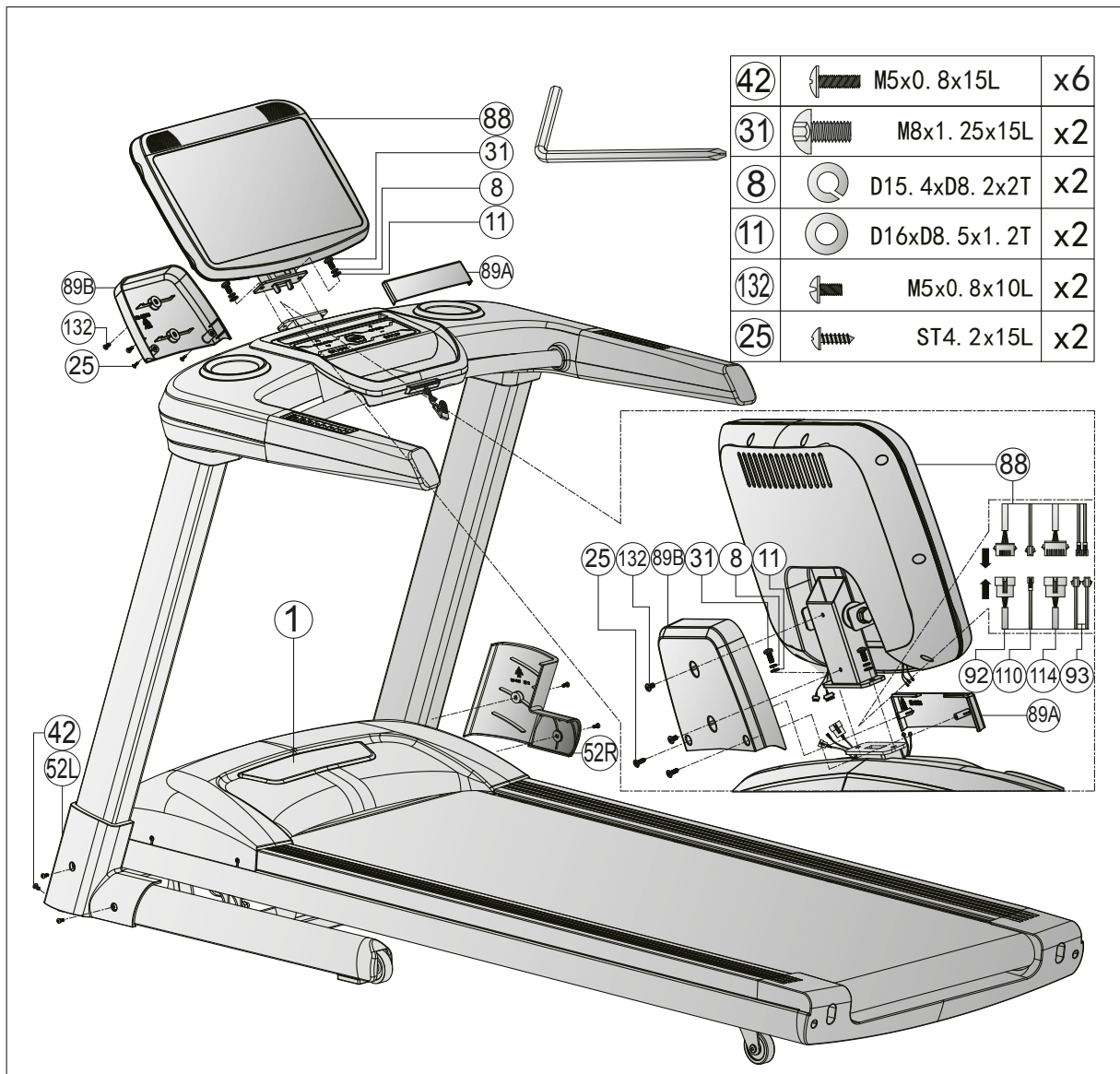

Step 4: Alignment of the feet

If the floor is uneven, you can stabilize the treadmill by turning the two setting screws under the main frame.

WARNING

The treadmill is equipped with high-pressure shock absorbers that can cause the treadmill to suddenly open if handled incorrectly. For more information, refer to the general assembly instructions.

1. Lift the treadmill on the desired side and rotate the setting screws under the main frame.
2. Rotate the screws clockwise in order to remove them and to raise the running surface.
3. Rotate them counterclockwise in order to lower the running surface.

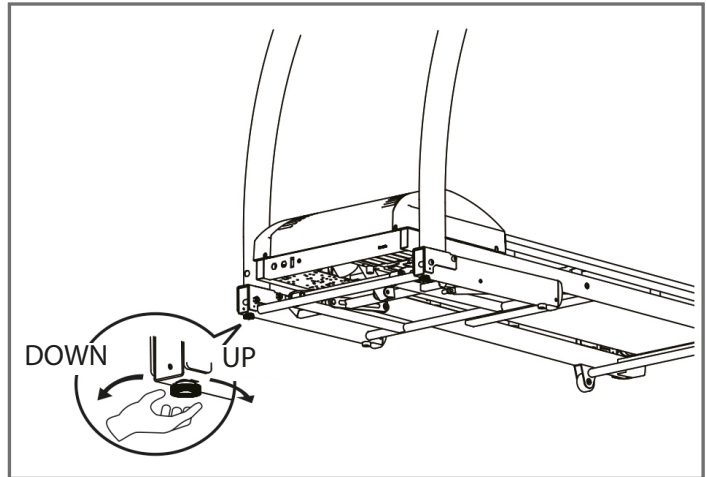

Step 5: Connecting the device to the mains supply

▶ ATTENTION

The device must not be connected to a multiple socket, otherwise it cannot be guaranteed that the device will be supplied with sufficient power. Technical errors can result.

Plug the power plug into a wall outlet that complies with the instructions in the chapter on electrical safety.

IMPORTANT NOTE

To ensure that your treadmill has the latest software version, please perform an update before using it for the first time. Proceed as follows:

1. Tap "Settings" in the lower right corner of the screen.
2. Tap "Wireless" and connect your treadmill to the Internet.
3. Return to the settings.
4. Tap "System and Apps" and go to updates.
5. Tap "Update", to update the software.

Do not use or switch off the treadmill during the update.

Check whether another update is available and carry it out as described above at regular intervals. If a new version is available, the display shows a white icon. Otherwise the icon will be grey.

ⓘ NOTICE

Familiarise yourself with all the functions and setting options of the device before starting training. Have the proper use of this product explained to you by a specialist.

SAFETY KEY**⚠ WARNING**

- + For your safety, the device is equipped with an EMERGENCY STOP function. The equipment can only be operated if the safety key is correctly attached to the contact point of the cockpit. If the safety key is no longer on the contact point, the equipment automatically stops. Therefore, the Safety Key cord with the clip must be attached to your clothing before every training session. If you want to quickly stop the treadmill, if you can no longer control the speed, or if another emergency occurs, remove the safety key from the cockpit using the cord.
- + To enable the safety key to detach from the contact point of the cockpit in the event of a fall, the safety key clip must be firmly attached to your clothing!
- + Make sure that the safety key is not accessible to children.

3.1 Console Display



Incline	Indicates the current incline level between 0 - 15 %.
Distance	Indicates the covered or remaining distance between 0.0 - 999 km.
Time	Indicates the already elapsed or remaining training time between 00:00 – 999:00 minutes.
Pulse	Indicates your current heart rate between 40 - 220 bpm.
Calories	Indicates the burnt calories between 0 – 9999 Kcal.
Mets	<p>Definition: MET or metabolic equivalent is used to measure the average metabolic rate for a person. MET describes the quantity of oxygen that an average person needs when in rest.</p> <p>1 MET = 3.5 ml/kg/min (The body consumes 3.5 milliliters of oxygen per kilogram per minute) is the amount of oxygen that the body needs when in rest.</p> <p>The more intensively the body works, the more oxygen is consumed and the higher the MET level. If you train at a level of seven METS, then you are working approximately 7 times harder than when in rest. Furthermore, you need 7 times as much oxygen than when in rest.</p> <ul style="list-style-type: none"> + Training between three to six METs is seen as moderate physical activity. + Training at more than six METs is seen as strong physical activity.
Speed	Indicates the current speed between 0,8 - 20 km/h.

3.2 Button Functions



START	With this button you can start a training programme. When you are in the main menu, you can start your training via quick start. When your training is paused, you can continue with your training by pressing this button.
STOP	With this button you can pause or end your training.
SPEED	With these buttons you can adjust the speed. You can adjust the speed in three ways: <ol style="list-style-type: none"> 1. The eight quick keys on the right hand rail (18/16/14/12/10/8/6/4). For example, when you press on the 14 the treadmill will adjust the speed to exact 14 km/h. 2. The buttons on the console (+ and -) 3. The buttons on the touch screen. <p>NOTE If you tap on the little icon between the buttons on the touch screen, you will be able to type in your desired speed.</p>
INCLINE	With these buttons you can adjust the incline. You can adjust the incline in three ways: <ol style="list-style-type: none"> 1. The eight quick keys on the left hand rail (15/13/11/9/7/5/3/0). When you press on the 13 the treadmill will adjust the incline to exact 13%. 2. The arrow buttons on the console. 3. The buttons on the touch screen. <p>NOTE If you tap on the little icon between the buttons on the touch screen, you will be able to type in your desired incline.</p>
COOL DOWN	With this button you can start the cool down phase at any time. Speed and incline will be reduced until the treadmill has come to a stop and has returned to its original position.

3.3 Training programmes

This treadmill offers many different programmes. This includes: a quick start programme, target programmes, pre-set programmes, user-defined programmes, heart rate-oriented programmes and one fitness test.

3.3.1 Quick Start

When you are in the main menu, simply press the START button to start a training session via quick start. Alternatively you can also tap on "QUICK START" in the main menu.

3.3.2 Target programmes

1. Tap on "GOAL" in the main menu.
2. Choose either time, distance or calories as your target unit.

① **NOTE:**

You can only choose one unit.

3. Set a value for your desired target unit.
4. Press the START button to start the programme.

The speed and the incline can be adjusted manually during your training.

5. Press the STOP button to pause your training.

The speed will be reduced slowly until the treadmill comes to a stop. In case an incline level has been set, the treadmill will remain in that position.

- 5.1. Press the STOP button again to end your training and an overview of the collected training data will be displayed.
- 5.2. Press the START button to continue with your training.

→ *Upon completion of the programme the console will start the cool down phase automatically.*

3.3.3 Pre-set programmes

1. Tap on „PROGRAM“ in the main menu.
2. Enter your gender, age, weight and the desired training time.
3. Choose one of the pre-set programmes.
4. Press the START button to start the programme.

The speed and the incline can be adjusted manually during your training.

5. Press the STOP button to pause your training.

The speed will be reduced slowly until the treadmill comes to a stop. In case an incline level has been set, the treadmill will remain in that position.

- 5.1. Press the STOP button again to end your training and an overview of the collected training data will be displayed.
- 5.2. Press the START button to continue with your training.

→ *Upon completion of the programme the console will start the cool down phase automatically.*

PROGRAM details

Program	Setting time / 30 = period in each section																														
	1	2	3	4	5	6	7	8	9	10	11	12	13	14	15	16	17	18	19	20	21	22	23	24	25	26	27	28	29	30	
P1	SPD	2	2	4	4	3	3	4	3	5	4	2	2	5	5	3	3	2	2	4	4	5	5	5	6	5	6	3	3	3	3
	INC	1	1	2	2	3	3	3	1	2	2	3	3	2	2	2	2	3	3	5	5	3	3	4	2	3	4	2	2	3	3
P2	SPD	2	2	5	5	4	4	6	4	6	4	2	2	4	4	2	2	2	2	4	4	6	6	8	7	8	6	2	2	3	3
	INC	1	1	2	2	3	3	3	2	2	3	4	4	2	2	2	2	3	3	5	5	4	4	4	3	4	4	3	3	1	1
P3	SPD	2	2	5	5	4	4	5	4	5	4	2	2	3	3	2	2	2	2	4	4	5	5	5	6	5	6	3	3	3	3
	INC	1	1	2	2	2	2	3	1	2	2	2	2	2	1	1	3	3	5	5	3	3	4	2	3	4	2	2	3	3	
P4	SPD	3	3	6	6	7	7	5	8	5	9	6	6	4	4	3	3	4	4	2	2	6	6	8	6	3	2	6	6	2	2
	INC	2	2	2	2	3	3	3	2	2	4	6	6	2	2	2	2	3	3	4	4	6	6	2	3	7	9	5	5	2	2
P5	SPD	3	3	6	6	7	7	5	8	6	7	6	6	4	4	3	3	2	2	5	5	5	5	4	4	6	4	2	2	3	3
	INC	1	1	2	2	4	4	3	2	2	4	5	5	2	2	1	1	3	3	5	5	6	6	7	8	9	10	10	8	2	2
P6	SPD	2	2	8	8	6	6	4	5	9	7	5	5	4	4	3	3	4	4	2	2	4	4	6	8	7	8	6	6	2	2
	INC	2	2	2	2	6	6	2	3	4	2	2	2	2	2	1	1	4	4	3	3	4	4	4	3	4	2	3	3	2	2
P7	SPD	2	2	6	6	7	7	4	4	7	4	2	2	4	4	2	2	3	3	5	5	4	4	4	3	4	3	2	2	2	2
	INC	4	4	5	5	6	6	6	9	9	10	7	7	6	6	3	3	4	4	2	2	4	4	6	8	7	8	6	6	2	2
P8	SPD	2	2	4	4	6	6	8	7	8	6	2	2	3	3	2	2	3	3	5	5	4	4	4	3	4	3	2	2	2	2
	INC	3	3	5	5	4	4	4	3	4	4	3	3	3	3	2	2	4	4	2	2	4	4	6	8	7	8	6	6	2	2
P9	SPD	2	2	4	4	5	5	5	6	5	6	3	3	3	3	2	2	3	3	4	4	4	4	3	5	5	6	3	3	3	3
	INC	3	3	5	5	3	3	4	2	3	4	2	2	3	3	2	2	3	3	5	5	4	4	4	3	4	3	2	2	2	2
P10	SPD	2	2	3	3	5	5	3	3	5	3	6	6	3	3	3	3	4	4	3	3	4	4	4	3	4	2	3	3	2	2
	INC	4	4	4	4	3	3	6	7	8	8	6	6	3	3	3	3	3	3	2	2	5	5	7	3	5	6	7	7	2	2
P11	SPD	3	3	5	5	8	8	8	9	5	7	6	6	3	3	2	2	3	3	4	4	6	6	2	3	7	9	5	5	2	2
	INC	4	4	5	5	6	6	6	9	9	10	8	8	6	6	3	3	3	3	4	4	4	4	3	5	5	6	3	3	3	3
P12	SPD	2	2	5	5	5	5	4	4	6	4	2	2	3	3	4	4	3	3	4	4	3	3	4	3	5	4	2	2	1	1
	INC	3	3	5	5	6	6	7	8	9	10	10	8	6	6	3	3	5	5	3	3	4	4	4	3	4	2	5	5	2	2
P13	SPD	4	4	2	2	6	6	8	6	3	2	6	6	2	2	2	2	3	3	10	10	7	7	10	7	10	7	7	2	2	
	INC	3	3	4	4	6	6	2	3	7	9	5	5	2	2	2	2	1	1	2	2	4	4	5	2	2	4	6	6	3	3
P14	SPD	3	3	4	4	4	4	3	5	5	6	3	3	3	3	2	2	5	5	3	3	4	4	4	3	4	2	5	5	2	2
	INC	3	3	5	5	4	4	4	3	4	3	2	2	2	2	4	4	2	2	5	5	4	4	2	4	2	4	2	2	4	4
P15	SPD	4	4	2	2	4	4	6	8	7	8	6	6	2	2	3	3	2	2	5	5	4	4	2	4	2	4	2	2	4	4
	INC	4	4	3	3	4	4	4	3	4	2	3	3	2	2	5	5	1	1	2	2	3	3	3	2	2	3	4	4	2	2
P16	SPD	3	3	2	2	5	5	7	3	5	6	7	7	2	2	1	1	2	2	5	5	4	4	5	4	5	4	6	6	3	3
	INC	3	5	9	10	9	9	8	8	4	3	3	3	2	2	4	4	1	1	2	2	2	2	3	1	2	2	1	1	2	2
P17	SPD	2	4	6	8	8	10	10	8	10	10	5	5	9	9	8	8	5	5	4	4	3	4	3	4	5	6	3	3	3	3
	INC	1	1	4	4	6	6	6	1	4	4	6	6	4	4	4	4	3	3	5	5	4	4	2	2	3	4	2	2	3	3
P18	SPD	3	5	10	10	7	7	8	10	8	10	10	10	7	7	5	5	7	7	10	10	9	9	8	8	4	3	3	3	2	2
	INC	1	1	4	4	4	4	6	1	4	4	6	6	8	8	4	4	5	5	10	10	8	8	10	8	10	10	5	5	2	1
P19	SPD	3	3	7	7	5	5	7	6	10	7	3	3	10	10	5	5	4	4	6	6	7	7	5	8	6	7	6	6	3	1
	INC	1	1	2	2	4	4	5	1	2	2	4	4	3	3	3	3	1	1	3	3	4	4	3	2	2	4	5	5	2	2
P20	SPD	3	3	10	10	7	7	10	7	10	7	7	7	7	7	3	3	4	4	6	6	7	7	5	8	6	7	6	6	3	3
	INC	1	1	2	2	4	4	5	2	2	4	6	6	3	3	2	2	1	1	3	3	4	4	3	2	2	4	5	5	2	2
P21	SPD	3	3	4	4	3	3	4	3	5	4	2	2	5	5	3	3	2	2	8	8	6	6	5	5	6	7	5	5	4	1
	INC	2	2	3	3	4	4	4	3	4	2	5	5	2	2	5	5	5	5	4	4	6	6	2	3	4	2	2	2	2	2
P22	SPD	2	2	5	5	4	4	2	4	2	4	2	2	4	4	2	2	3	3	5	5	4	4	4	3	4	4	3	3	3	3

	INC	1	1	2	2	3	3	3	2	2	3	4	4	2	2	3	3	5	5	4	4	3	4	3	4	5	6	3	3	3	3
P23	SPD	2	2	5	5	4	4	5	4	5	4	6	6	3	3	2	2	3	3	5	5	8	8	8	9	5	7	5	6	4	2
	INC	1	1	2	2	2	2	3	1	2	2	1	1	2	2	1	1	5	5	6	5	6	5	6	9	9	10	10	8	6	3
P24	SPD	3	3	6	6	5	7	5	8	5	9	6	6	4	4	3	3	2	2	8	8	6	6	5	5	6	7	5	5	4	4
	INC	1	1	2	2	3	3	3	2	2	4	6	6	2	2	1	1	5	5	4	4	6	6	2	3	4	2	2	2	2	2
P25	SPD	4	4	6	6	7	7	5	8	6	7	6	6	5	5	3	3	4	4	2	2	5	6	8	7	8	6	5	4	3	3
	INC	1	1	3	3	4	4	3	2	2	4	5	5	2	2	1	1	3	3	5	5	4	4	4	3	4	4	3	3	3	3
P26	SPD	2	2	8	8	6	6	5	5	6	7	5	5	4	4	3	3	2	2	5	5	5	5	4	4	6	4	2	2	3	3
	INC	1	1	4	4	6	6	2	3	4	2	2	2	2	2	1	1	3	3	5	5	6	6	7	8	9	10	10	8	6	2
P27	SPD	2	2	6	6	7	7	4	4	7	4	3	3	4	4	2	2	4	4	5	5	6	6	6	9	9	10	8	8	6	3
	INC	4	4	5	5	6	6	7	9	9	10	10	10	6	6	3	3	2	2	5	5	5	5	4	4	6	4	2	2	3	3
P28	SPD	4	4	2	2	5	6	8	7	8	6	5	4	3	3	2	2	5	5	3	3	4	4	4	3	4	2	5	5	2	2
	INC	3	3	5	5	4	4	4	3	4	4	3	3	3	3	2	2	2	2	5	5	4	4	2	4	2	4	2	2	1	1
P29	SPD	2	5	6	6	3	4	3	4	5	6	3	3	3	3	2	2	4	4	3	3	4	3	5	4	2	2	5	5	3	3
	INC	3	3	5	5	4	4	2	2	3	4	2	2	3	3	2	2	3	3	4	4	4	3	4	2	5	5	2	2	1	1
P30	SPD	3	5	3	3	5	5	4	4	5	3	6	6	3	4	3	2	3	3	4	4	3	3	4	3	5	4	2	2	2	1
	INC	4	4	1	1	3	3	6	7	8	8	7	7	3	3	3	3	5	5	3	3	4	4	4	3	4	2	5	5	2	2
P31	SPD	3	3	5	5	8	8	8	9	5	7	5	6	4	4	2	2	4	4	5	5	6	6	6	9	9	10	8	8	6	3
	INC	1	3	6	5	6	5	6	9	9	10	10	10	8	6	4	3	2	2	5	5	5	5	4	4	6	4	2	2	3	3
P32	SPD	2	4	5	4	5	5	6	8	6	4	3	2	3	3	4	4	3	3	10	10	7	7	10	7	10	7	7	7	3	3
	INC	3	3	5	5	6	6	7	8	9	10	10	10	7	6	3	3	1	1	2	2	4	4	5	2	2	4	6	6	3	3

3.3.4 User-defined programmes

1. Tap on "USER PROGRAM" in the main menu.
2. Choose one of the four user profiles (U1-U4).

NOTE

The chosen user profile will be displayed on the upper border of the screen. The name of the user profile can be changed. To do this, simply tap on the user profile and type in the desired name.

3. Enter your gender, age, weight and the desired training time.
4. Set the desired speed and incline for all the 30 segments.

The speed and the incline can be adjusted manually during your training. But only in the respective segment.

5. Press the START button to start the programme.
6. Press the STOP button to pause your training.

The speed will be reduced slowly until the treadmill comes to a stop. In case an incline level has been set, the treadmill will remain in that position.

- 6.1. Press the STOP button again to end your training and an overview of the collected training data will be displayed.
- 6.2. Press the START button to continue with your training.

→ *Upon completion of the programme the console will start the cool down phase automatically.*

3.4 Heart Rate Oriented Programmes

WARNING

Your training equipment is not a medical device. The heart rate measurement of this equipment may be inaccurate. Various factors can affect the accuracy of the heart rate measurement. The heart rate measurement serves only as a training aid.

There are three different heart rate-oriented programmes. Either choose one of the pre-set target heart rates (60% or 80% of your maximum heart rate) or choose „Target HR“ to set a target heart rate yourself. Your maximum heart rate is calculated depending on your age. We recommend a chest strap for these programmes.

1. Tap on „HRC“ in the main menu.
2. Enter your gender, age, weight and the desired training time.
3. Choose either 60%, 80% or Target HR.
- 3.1. If you have chosen Target HR you will be able to set the target value yourself (between 72-168).

The incline can be adjusted manually during your training. The speed is regulated according to your incoming heart rate.

4. Press the START-button to start the programme.
5. Put your hands around the hand pulse sensors or use a chest strap.

NOTE

In case the console does not receive a signal for 15 seconds the programme will be stopped.

6. Press the STOP-button to pause your training.

The speed will be reduced slowly until the treadmill comes to a stop. In case an incline level has been set, the treadmill will remain in that position.

- 6.1. Press the STOP-button again to end your training and an overview of the collected training data will be displayed.
- 6.2. Press the START-button to continue with your training.

→ *Upon completion of the programme the console will start the cool down phase automatically.*

3.5 Fitness test

The fitness test consists of two phases. One is the warm up phase and the other is the actual fitness test. We recommend a chest strap for this test.

NOTE

The speed will be adjusted automatically in dependence of your heart rate. The incline can not be adjusted.

1. Tap on "FITNESS TEST" in the main menu.
2. Enter your gender, age and weight.
3. Press the START button to start the fitness test.

The warm up phase will start.

NOTE

We recommend to use this phase if you have not done a warm up beforehand. Otherwise the warm up phase can be skipped by tapping on "SKIP WARM UP".

4. Put your hands around the hand pulse sensors or use a chest strap.

NOTE

In case the console does not receive a signal for 15 seconds the programme will be stopped. If your heart rate gets to high the console will display "OVER PULSE". In this case, please interrupt your test immediately.

→ *Upon completion of the test an overview of the collected training data will be displayed.*

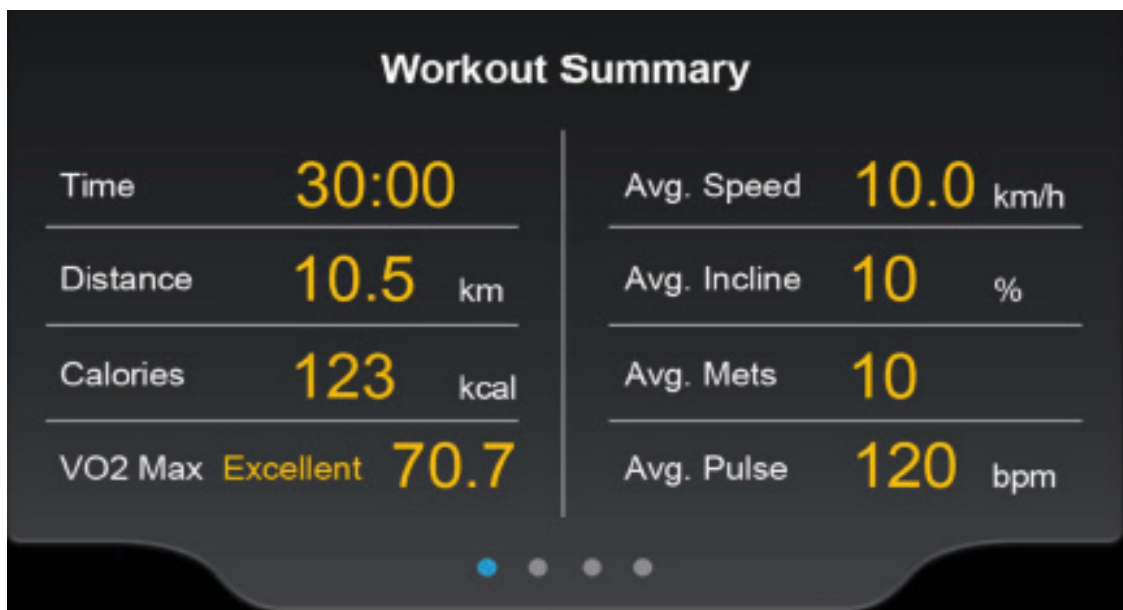

3.6 Media

Here you will find many different apps like YouTube, Twitter, Facebook or Instagram.

IMPORTANT NOTE

To make sure the pre-installed apps are working correctly, they must be updated regularly. If needed, the respective app will notify you to do so. To update the app, you need a google account. A google email is sufficient. Just follow the instructions on the screen to perform the update.

Please note: The system is set up only for the pre-installed apps. Do not install any additional apps as their proper functionality can not be guaranteed. The installation of other apps might cause technical issues.

This menu can be opened in two ways:

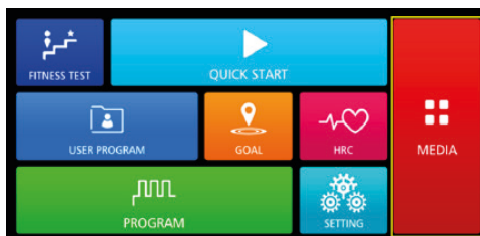

1. Via the main menu by tapping on „MEDIA“ or
2. Via the training interface (in the upper left corner of the screen).

NOTE

You can show and hide the training interface by tapping on the round icon on the right edge of the screen. To adjust the volume simply tap on the speaker icon.

You can transmit music and video data from your USB stick to the console. To do this insert your USB stick into the corresponding slot on the side of the console.

Supported formats:

Music: .wav, .wma, .aac, .ogg, .mp3 und .flac.

Video: .mp4 und .avi.

Settings

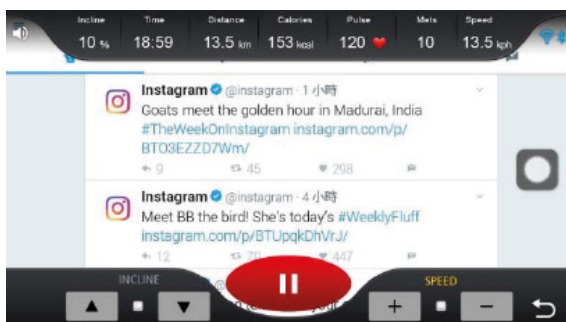

Under „SETTINGS“ in the main menu, you can make your system settings. This includes:

Language, screen brightness and volume.

Bluetooth: You can connect your mobile device and bluetooth speakers with the console.

Wireless: Here you can connect the console with the internet.

4.1 General Instructions



WARNING

- + The storage location should be chosen so that improper use by third parties or children can be prevented.
- + If your equipment does not have transportation wheels, the equipment must be disassembled before transportation.



ATTENTION

- + Make sure that the equipment is protected from moisture, dust and dirt in the selected storage location. The storage location should be dry and well ventilated and have a constant ambient temperature between 5°C and 45°C.

4.2 Transportation Wheels



ATTENTION

If you want to transport your equipment over particularly sensitive and soft floor coverings, such as parquet, planks or laminate, lay out the transport route with cardboard or similar to avoid possible floor damage.

1. Stand behind the equipment and lift it until the weight is transferred to the transportation wheels. After that, you easily can move the equipment to a new position. For long transport distances the equipment should be disassembled and safely packed.
2. Select the new location by following the instructions in the section 1.4 of this manual.

4.3 Folding Mechanism



WARNING

- + The treadmill is equipped with high-pressure shock absorbers that can cause the treadmill to suddenly open if handled incorrectly. For more information, refer to the general assembly instructions.
- + Do not lift the treadmill by the running mat or the rear transporting wheels. These parts do not lock and are difficult to grab.



NOTICE

The treadmill is foldable and thus saves space when it is stored. It also makes it easier to transport.

4.3.1 Folding Up the Treadmill

⚠ WARNING

- + Do not connect the equipment to the power supply when it is folded up. Try not to operate the equipment when it is folded up.
- + The running surface must have come to a complete stop before folding.

⚠ CAUTION

- + Do not lean on the equipment when it is folded and do not place anything on top of it that may make the equipment unstable or fall down.

▶ ATTENTION

- + Make sure that nothing is standing next to or on top of the treadmill that can be spilled or thrown or that makes it impossible to fold the treadmill.

1. Turn off the on/off switch and remove the plug from the outlet.
2. Use both hands to grab the supportive bar directly under the rear part of the running mat so that you have a stable lifting point.
3. Make sure that the hydraulic brake is correctly locked and tilt the treadmill forward.
4. Make sure that you are standing safely and make sure that the locking mechanism is secure by pulling the equipment backwards and it does not move.

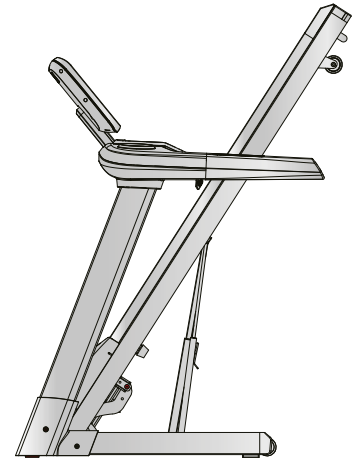

4.3.2 Unfolding the Treadmill

▶ ATTENTION

- + Make sure that nothing is standing next to or on top of the treadmill that can be spilled or thrown or that makes it impossible to unfold the treadmill.

1. Stand behind the treadmill and push the device slightly forward towards the display.
2. To release the hydraulic brake lock, use your left foot to push the upper part of the hydraulic brake slightly forward until the lock releases and the treadmill can be pulled back.
3. Keep holding the treadmill.

The hydraulic brake lowers itself gently downwards.

4. Once the treadmill has lowered 2/3, you can let go of the treadmill.

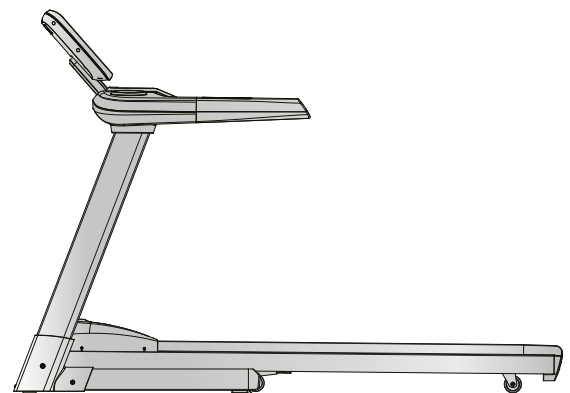

5.1 General Instructions



WARNING

+ Do not make any improper changes to the equipment.



CAUTION

+ Damaged or worn components may affect your safety and the life of the equipment. Therefore, immediately replace damaged or worn components. In such a case, contact the contract partner. The equipment must not be used until it has been repaired. If necessary, use only original spare parts.

ATTENTION

+ In addition to the instructions and recommendations for maintenance and care given here, additional service and/or repair work may be necessary; this must only be carried out by authorised service technicians.

5.2 Faults and Fault Diagnosis

The equipment undergoes regular quality controls during production. Nevertheless, faults or malfunctions may occur. Frequently, individual parts are responsible for these disturbances, an exchange is usually sufficient. Please refer to the following overview for the most common errors and how to correct them. If the equipment still does not function properly, contact your contract partner.

Fault	Cause	Solution
Console is not responding	Safety key missing or not inserted correctly	Check whether Safety Key is inserted and insert if necessary
Running mat slanting	Running mat not centered	Adjust the running mat according to the instructions
Grinding noises		
Running mat slips through/stops	Tape tension/lubrication not correct	Check belt tension/lubrication according to instructions
Display is blank/is not working	+ Interrupted power connection + Loose cable connections	+ Power switch to on + Check whether Safety Key is plugged in + Check cable connections
No pulse display	+ Sources of interference in the room + unsuitable chest strap + Wrong position of chest strap + Chest strap defective or battery empty + Pulse display defective	+ Eliminate sources of interference (e.g. mobile phone, WLAN, lawn mower and vacuum cleaner robot, etc. ...) + Use a suitable chest strap (see RECOMMENDED ACCESSORIES). + Reposition chest strap and/or moisten electrodes + Changing batteries + Check if pulse display by hand pulse possible

5.3 Care and Maintenance

The most important maintenance measure is the care of the running mat. This includes adjustment, re tensioning and lubrication of the running mat. Damage resulting from insufficient or neglected care is not covered by the warranty. You should therefore carry out maintenance checks at regular intervals. Be very careful when adjusting and tightening the running mat, as a strong over voltage or under voltage can cause damage to the equipment. The running mat is adjusted at the factory according to the regulations before delivery. However, it may happen that the running mat slips during transport.

By scanning the QR code with the camera function or QR code scanner app of your smartphone/tablet, a video on general maintenance of a treadmill opens on YouTube. The video serves to illustrate the maintenance points described in this manual.

Please note that the video may not be available in your language or with appropriate subtitles.

If you cannot scan QR codes, you can access all Sport-Tiedje videos on YouTube by first opening YouTube and entering "Sport-Tiedje" in the search field.



5.3.1 Adjusting the Running Mat

During training, the running mat should run as centrally and straight as possible. The alignment of the running mat can change depending on the stress and load. Another reason can be the positioning of the equipment on an uneven surface.

CAUTION

During the following maintenance nobody must be on the treadmill!

1. Let the treadmill run at a speed of 5 km/h.
2. If the running mat deviates to the left, turn the left adjusting screw at the rear end of the device max. one $\frac{1}{4}$ turn clockwise and the right adjusting screw max. one $\frac{1}{4}$ turn anticlockwise.
3. If the running mat deviates to the right, turn the right adjusting screw at the rear end of the device max. $\frac{1}{4}$ turn clockwise and the left adjusting screw max. $\frac{1}{4}$ turn anticlockwise.
4. Then observe the mat for about 30 seconds, as the change is not immediately visible.
5. Repeat this procedure until the running mat is straight again. If the running mat cannot be adjusted, please contact your contract partner.

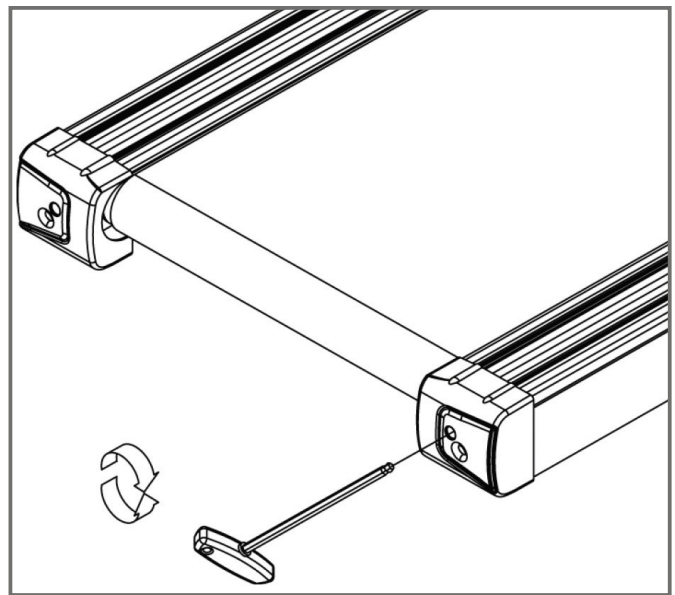

5.3.2 Re-tensioning the Running Mat

If the running mat slips over the rollers during operation (if this is the case, there is a noticeable jerk during running), the running mat must be re tightened.

In most cases, the slipping is caused by stretching of the mat through use. This is perfectly normal.

① NOTICE

Re-tensioning is carried out using the same adjusting screws that are used for adjustment.

1. Let the treadmill run at a speed of 5km/h.
2. Turn the left and right adjusting screws directly one after the other, max. one ¼ turn clockwise.
3. Then check whether the running mat continues to slip. If this is the case, you must perform the described procedure again.

5.3.3 Lubricating the Running Mat

If the running mat is not sufficiently lubricated, friction increases significantly and this leads to heavy wear of the endless belt, running plate, motor and circuit board. If you feel an increased friction of the running mat, this is an indication that you should lubricate the mat. However, lubrication should be carried out at least every 3 months or every 50 operating hours. Whichever case comes first.

① NOTICE

If your treadmill is equipped with a folding mechanism, you can also lubricate it when it is folded.

1. Raise the running mat slightly.
2. Apply some lubricating oil or silicone spray to the entire deck and distribute evenly.
3. Continue turning the belt by hand so that the entire surface between the endless belt and the running plate is lubricated.
4. Wipe off the excess lubricating oil or silicone spray.

① NOTICE

This maintenance must also be carried out after prolonged non-use of the equipment.

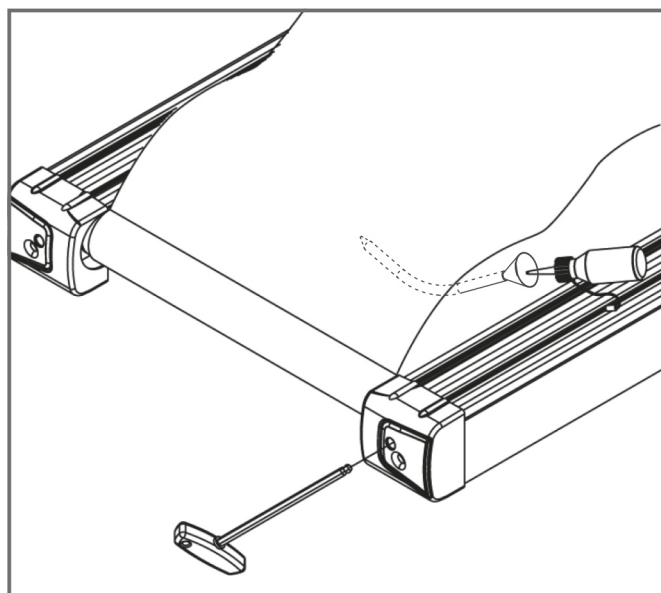

5.4 Maintenance and Inspection Calendar

To avoid damage from body sweat, the equipment must be cleaned with a damp towel (no solvents!) after each training session.

The following routine tasks must be performed at the specified intervals:

Part	Weekly	Monthly	Quarterly
Display console	C	I	
Tension of the running mat			I
Lubrication of the running mat			I
Plastic covers	C	I	
Screws and cable connections			I
Legend: C = clean; I = inspect			

By scanning the QR code with the camera function or QR code scanner app of your smartphone/tablet, a video on general maintenance of a treadmill opens on YouTube. The video serves to illustrate the maintenance points described in this manual.

Please note that the video may not be available in your language or with appropriate subtitles.

If you cannot scan QR codes, you can access all Sport-Tiedje videos on YouTube by first opening YouTube and entering "Sport-Tiedje" in the search field.



6 DISPOSAL

At the end of its operational life, this equipment cannot be disposed of in normal household waste. Instead, it must be disposed of via an electricals recycling centre. Further information can be obtained from your local authority's recycling service.

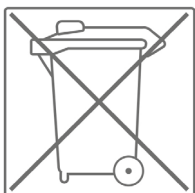

The materials can be recycled as per their symbols. Through the reuse, recycling of materials or other forms of recovery of old equipment, you make an important contribution to the protection of the environment.

To make your training experience even more efficient and pleasant, we recommend that you add suiting accessories to your fitness equipment. This could be a floor mat, for example, which makes your fitness equipment stand more securely and also protects the floor from falling sweat, but it could also be additional handrails on some treadmills or silicone spray to keep moving parts in good shape.

If you have purchased a fitness machine with pulse training and want to train your heart rate, we strongly recommend that you use a compatible chest strap, as this ensures optimum transmission of the heart rate. You may want to buy additional grips or weights for multi gyms.

Our range of accessories offers the highest quality and makes training even better. If you would like to find out more about compatible accessories, please go to the detail page of the product in our webshop (the easiest way is to enter the article number in the search field above) and go to the recommended accessories on this page. Alternatively, you can use the QR code provided. Of course, you can also contact our customer service: by telephone, e-mail, in one of our branches or via our social media channels. We will be happy to advise you!



floor mat



chest strap



Chest strap contact gel



towels



silicone spray

8.1 Serial Number and Model Name

In order to provide you with the best possible service, please have the model name, article number, serial number, exploded drawing and parts list ready. The corresponding contact options can be found in chapter 10 of this operating manual.

NOTICE

The serial number of your equipment is unique. It's located on a white sticker. The exact position of this sticker is shown in the following illustration.

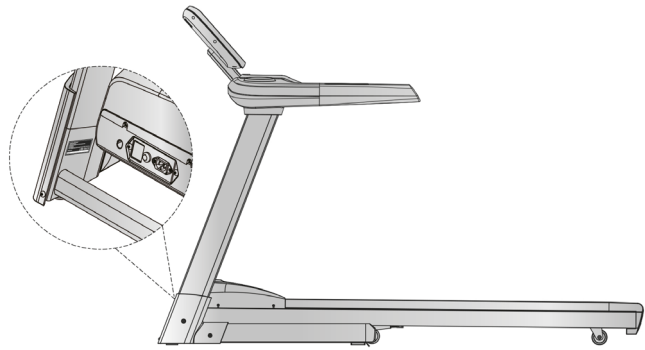

Enter the serial number in the appropriate field.

Serial number:

Brand / Category:

Model Name:

Article Number:

8.2 Parts List

No.	Name	Supplier Parts No.	Specification	Qty.
1	Main frame	261D8-3-1000-J0		1
2	Left handlebar post	26100-3-1300-J2		1
3	Right handlebar post	26100-3-1400-J2		1
4	Handlebar	261D8-3-1500-B20		1
5	Base tube	26100-3-1600-J2		1
6	Connecting tube	26100-3-1900-J1		1
7	Allen bolt	50108-5-0020-F0	M8x1.25x20L	8
8	Spring washer	55108-2-1520-FA	D15.4xD8.2x2T	12
9	Flat washer	55108-1-2520-FA	D25xD8.5x2T	8
10	Allen screw	54008-5-0030-F0	M8*1.25*30L	4
11	Flat washer	55108-1-1612-FA	D16*D8.5*1.2T	5
12	Running belt	261D8-6-1072-B0	520*2.5T*3200L	1
13	Wooden board	26100-6-1073-B0	1400*625*18T	1
14	Side plate	261A2-6-1076-B0	92.7*39.2*1430L	2
15	Buffer bar	26100-6-1084-B0	25*2T*1380L	2
16	CSK inner hexagon screw	51608-5-0025-F0	M8*1.25*25L	8
17	Buffer 1(red)	26100-6-1081-R0	D30*37L*M8,45degree	2
18	Buffer 2(blue)	26100-6-1082-K0	D30*37L*M8,75degree	2
19	Buffer 3(black)	26100-6-1083-B0	D30*37L*M8,95degree	2
20	Buffer 4(black plated)	26100-6-1088-F0	D30*37L*M8,full metal	2
21	Roller	26100-6-1087-B0	D65*24	4
22	Buffer	23800-6-1272-04	D33*D44*34.5	2
23	Nylon nut	55208-1-2008-FA	M8*1.25*8T	12
24	Metal clip	26100-6-1086-N0	D27*D4.3*2T	10
25	Screw	52842-2-0015-F0	ST4.2*15L	80
26	Motor cover fixing plate	26100-6-1090-00	32*18*18	4
27	cable tie base	26100-6-1089-00	15*10	5
28	Screw	50904-2-0015-N0	ST4*1.41*15L	6
29	Fixing plate	81650-6-1673-N0	30*27*4T	2
30	Motor	26100-6-1085-03	DC-3.5HP	1
31	Allen bolt	50308-5-0015-F0	M8*1.25*15L	6

32	Buffer	78000-6-1081-B2	20*56*2.0T	4
33	Allen screw	54010-5-0030-C3	M10*1.5*30L	6
34	Allen bolt	50308-5-0040-F3	M8*1.25*40	3
35	Front roller set	26100-3-1100-01	D17*D60*625L	1
36	Rear roller set	261D1-3-1200-01	D17*D60*620L	1
37	Belt	58004-6-1101-00	PJ8 227	1
38	Allen screw	54008-5-0075-F0	M8*1.25*75L	4
39A	Upper cover	261D8-6-1576-B0	388.6*895.3*85	1
39B	Lower cover	26100-6-1577-B0	388.8*395.3*137.4	1
40	Water bottle holder	26100-6-1578-B0	D134*115	2
41A	Upper cover for button base	261D8-6-1709-B0	346*303*83	1
41B	Lower cover for button base	261D8-6-1710-B0	346*123*73	1
42	Bolt	52605-2-0015-F0	M5*0.8*15L	16
43L	Left handlebar grips	26100-6-1571-B0	95.5*79.3*438.2L	1
43R	Right handlebar grips	26100-6-1572-B0	95.5*79.3*438.2L	1
44L	Upper handle pulse sensor	26100-6-1574-B0	D32*135L	2
44R	Lower handle pulse sensor	26100-6-1573-B0	D32*135L	2
45	Bottle pad	261D8-6-1754-B0	D80*3T	2
46L	Quick button on left bar	261D8-2-1580-00	185*37	1
46R	Quick button on right bar	261D8-2-1590-00	185*37	1
47	Adjustable wheel	74202-6-2174-N0	D50*M10*1.5	2
48	Flat washer	55110-1-2520-FA	D25*D10*2.0T	6
49	Axle	26100-6-1673-N0	D7.9*30.5L	2
50	Cover for transporting wheel	26100-6-1672-B0	55*80*69.4L	2
51	Square buffer	26100-6-1674-B0	60*42*10.5T, 80degree	2
52L	Left cover for end of handlebar post	261D2-6-1371-B0	299*55*211	1
52R	Right cover for end of handelbar post	261D2-6-1471-B0	299*55*211	1
53	Square cap	55310-2-2020-B1	20*20*1.5T*9.5	1
54	Square cap	55316-2-3030-B8	30*30*14	1
55	Bolt	52605-2-0010-N0	M5*0.8*10L	11
56	Folding unit	26100-3-1650-J1		1
57	Locking bracket	26100-3-1660-J0		1
58	Inner tube of folding unit	26100-6-1652-N1	20*20*1.5T*440L	1

59	Spring	58003-6-1069-N0	D1.5*14.6L	1
60	Cylinder	26100-6-1661-B0	760*53KG	1
61	Allen bolt	50308-5-0030-F0	M8*1.25*30	2
62	Hollow cap	26100-6-1676-B0	30*30*65L	1
63	Allen bolt	50308-5-0050-F3	M8*1.25*50	1
64	Allen screw	54006-5-0035-F3	M6*1.0*35L	1
65	Nylon nut	55206-1-2006-FA	M6*1.0*6T	1
66	Flat washer	55108-1-1810-W8	D18*D8.5*1.0T	4
67	Allen bolt	50310-5-0035-F3	M10*35L	4
68	Bushing	58002-6-1104-UC0	D28*D10*9.2	4
69	Plastic washer	55110-1-2404-BF	D10*D24*0.4T	4
70	Incline motor	26100-6-1975-00	JS11-B	1
71	Flat washer	55110-1-2020-FA	D20xD11x2T	8
72	Spring washer	55110-2-1730-FA	D17.8*D10.2*3.0T	6
73	Nylon nut	55210-1-2010-FA	M10x1.5x10T	10
74	Allen bolt	54010-8-0065-F4	M10*1.5*65L	1
75	Allen bolt	54010-8-0050-F4	M10*1.5*50L	1
76	Flat washer	55110-1-3030-FA	D30*D10*3.0T	2
77A	Upper cover for motor	26100-6-2401-B0	725*416.6*120.4	1
77B	Lower cover for motor	26100-6-2402-B0	729*80*54.8	1
78	Decorative cover for motor	261D8-6-2403-B0	323.9*87.7*22.6	1
79	rear cover	261D8-6-2406-B0	729.5*153.6*135	1
80	Power supplier board	26100-6-2414-B0	130*45*6T	1
81	Switching mode power supplier	26100-6-2411-00		1
82	overcurrent protector	26100-6-2412-00	10A	1
83	Socket	26100-6-2413-00		1
84	Buffer	55308-4-0020-G9	D10.5*20L	2
85	Screw	53329-2-0009-D0	ST2.9x9.5L	36
86	Flat washer	55105-1-1208-DA	D12*D5.2*0.8T	4
87	Nylon nut	55205-1-2005-DA	M5*0.8*5T	2
88	Computer set	261D8-2-1700-B0		1
89A	Decorative cover for computer	261D8-6-1749-B0	202*49*23	1
89B	Back computer cover	261D8-6-1748-B0	202*178*37	1
90A	Upper computer cover	261D8-6-1702-B0	454.2*348*44.3	1
90B	Lower computer cover	261D8-6-1703-B0	454.2*344.5*60.5	1

91	Button plate	261D8-6-1756-B0	267.2*95.3*13.5	1
92	Upper cable for button on side bar	261D8-6-1589-01	500L	1
93	Handle pulse cable	261D8-6-1785-00	1000L	2
94	Button overlay	261D8		1
95	Right speaker	261D8-6-1761-00	B00202050,4Ω 3W 100L	1
96	LED light connecting plate	261D1-6-1744-00	PA-AA01170-K5	1
97	Backlight plate	261D2-6-2405-01	190*25	1
99L	Lower cable for button on left bar	261D8-6-1582-00	800L	1
99R	Lower cable for button on right bar	261D8-6-1592-00	800L	1
100	Sensor cable	26100-6-1795-00	GS003-P2.5F-1200mm-26AWG	1
101	Magnetic loop	26100-6-1079-00	D31*16	1
102	Safety key	26200-6-1732-R0	78.6*35*18.2	1
103	Left speaker	261D8-6-1722-01	B00202050,4Ω 3W, 300L	1
104	Inner case of safety key	26100-6-1734-B0	39*15*13.3	2
105	Safety key board	26200-6-1733-B0	74*45*7	1
106	Safety clip	26200-6-1793-R0	830L	1
107	Emergency stop pin	26100-6-1731-C1	21*18*1.5T	1
108	Tablet pad	261D8-6-1777-B0		1
110	Cable for emergency stop function	261D8-6-1736-00	450L	1
111	Electric cable	26100-6-1775-02	1700L	1
112	Filter	26100-6-1067-01	10A	1
113	Inductance	26100-6-1066-00	10A	1
114	Upper computer cable	261D8-6-1771-01	650L	1
115	Middle computer cable	261D8-6-1772-00	1100L	1
116	Lower computer cable	261D8-6-1773-00	1250L	1
117	neutral wire 1	26100-6-1791-00	100L	2
118	neutral wire 2	26100-6-1792-00	190L	1
119	live wire 1	26100-6-1789-00	100L	1
120	live wire 2	26100-6-1790-01	60L	2
121	Lower controller	261D8-6-1779-00	DC3.0HP,PA-AE00300EH	1
122	Grounding wire 1	26100-6-1787-03	325L	2
123	Grounding wire 2	26100-6-1788-00	100L	1

126	Cross bolt	52606-2-0015-F0	M6*1*15L	4
127	Cross support for computer cover	261D8-6-2001-J0	10*20*1.5T*320L	1
128	USB module	261D8-6-1723-00	PA-AC00380-K2	1
129	Round head cross screw	54723-2-0008-C0	ST2.3*8L	19
130	PC sticker	26100-6-1675-00	410*15*0.25T	1
131	Hex nut	55210-2-2008-FA	M10*1.5*8T	2
132	Cross bolt	52605-2-0010-F0	M5*0.8*10L	2
133	Cross screw	52804-2-0012-F0	ST4*1.41*12L	6
134	Welding set for computer cover	261D8-3-2000-J0		1
135	Fixing plate for computer	261D8-3-1530-J0		1
136	Flat washer	55105-1-1510-DA	D15*D5.2*1.0T	4
137	Round head cross screw	50903-2-0025-F0	ST3*25L	4
138	Round end cap	553K0-1-0016-B8	D 1 1/4"x16L	2
139	PCB board for button	261D8-6-1759-00		1
140	Air Buffer	261D8-6-1061-R0	200*43*37	2
141	Allen screw	54008-5-0016-UFO	M8*1.25*16L	2
	Open mouth spanner 13*15(chrome)	58030-6-1050-C0	153*6.5T	1
	Allen cross spanner	58030-6-1051-N0	M6*130L	1

8.3 Exploded Drawing

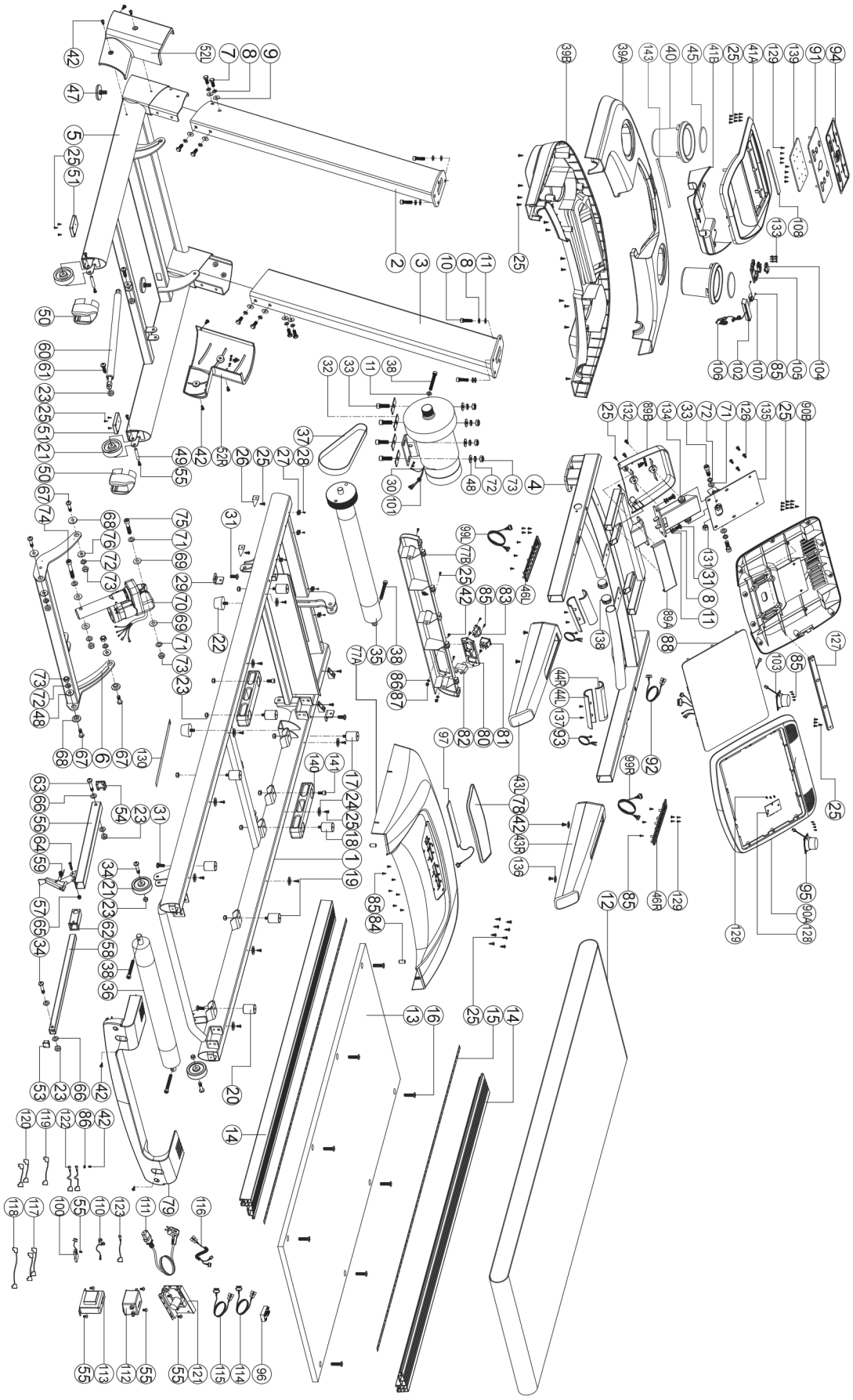

Training equipment from Taurus® is subject to strict quality control. However, if a fitness equipment purchased from us does not work perfectly, we take it very seriously and ask you to contact our customer service as indicated. We are happy to help you by phone via our service hotline.

Error Descriptions

Your fitness equipment is developed for long-term, high-quality training. However, should a problem arise, please first read the operating instructions. For further assistance, please contact your contract partner or call our service hotline. To ensure your problem is solved as quickly as possible, please describe the defect as exactly as possible.

In addition to the statutory warranty, we provide a warranty for every fitness equipment purchased from us according to the following provisions.

Your statutory rights are not affected.

Warrantee

The warrantee is the first/original buyer and/or any person who received a newly purchased product as a gift from the original buyer.

Warranty period

The warranty periods, shown on our web shop, begin on delivery of the fitness equipment. The respective warranty periods for your equipment can be found on its product website.

Repair Costs

According to our choice, there will either be a repair, a replacement of individual damaged parts or a complete replacement. Spare parts, that have to be mounted while assembling the equipment, have to be replaced by the warrantee personally and are not a part of repair. After the expiration of the warranty period for repair costs, a pure parts warranty applies, which does not include the repair, installation and delivery costs.

The terms of use are defined as follows:

- + Home use: solely for private use in private households up to 3 hours per day
- + Semi-professional use: up to 6 hours per day (e. g. rehabilitation centres, hotels, clubs, company gyms)
- + Professional use: more than 6 hours per day (e. g. commercial gyms)

Warranty Service

Within the warranty period, equipment which develops faults as a result of material or manufacturing defects, will be repaired or replaced at our discretion. Ownership of equipment or parts of equipment which have been replaced is transferred to us. The warranty period is not extended nor does a new warranty period begin following repair or replacement under the warranty.

Warranty Conditions

For the warranty to be valid, the following steps must be taken:

Please contact our customer service by email or phone. If the product under warranty has to be sent in for repair, the seller bears costs. After expiry of the warranty, the buyer bears the costs of transport and insurance. If the fault is covered by our warranty, you will receive a new or repaired equipment in return.

Warranty claims are invalid in case of damage resulting from:

- + misuse or improper handling
- + environmental influences (moisture, heat, electrical surge, dust, etc.)
- + failure to follow the current safety measures for the equipment
- + failure to follow the operating instructions
- + use of force (e. g. hitting, kicking, falling)
- + interventions which were not carried out by one of our authorized service centres
- + unauthorised repair attempts

Proof of Purchase and Serial Number

Please make sure that you are able to provide the appropriate receipt when claiming on your warranty. So that we can clearly identify the model of your equipment, and for the purposes of our quality control, you will need to give the serial number of your equipment, when contacting the service team. Where possible please have your serial number and your customer number ready when you call our service hotline. It will help us to deal with your request swiftly.

If you cannot find the serial number on your fitness equipment, our service team is at your disposal to offer further information.

Service outside of the Warranty Period

We are also happy to issue an individual cost estimate if there is a problem with your fitness equipment after the warranty has expired, or in cases which do not fall under the terms of the warranty, e. g. normal wear and tear. Please contact our customer service team to find a quick and cost-effective solution to your problem. In such a case you will be responsible for the delivery costs.

Communication

Many problems can be solved just by speaking to us as your specialist supplier. We know how important it is to you as a user of the fitness equipment to have problems solved quickly and simply, so you can enjoy working out with minimal interruption. For that reason, we also want to resolve your queries quickly and in a straightforward manner. Thus, please always keep your customer number and the serial number of the faulty equipment handy.

DE	DK	FR
<p>TECHNICAL SUPPORT</p> <p>☎ +49 4621 4210-900 📠 +49 4621 4210-698 ✉ technik@sport-tiedje.de</p> <p>🕒 Mo - Fr 08:00 - 18:00 Sa 09:00 - 18:00</p> <p>SERVICE</p> <p>☎ 0800 20 20277 (Freecall)</p> <p>✉ info@sport-tiedje.de</p> <p>🕒 Mo - Fr 08:00 - 21:00 Sa 09:00 - 21:00 So 10:00 - 18:00</p>	<p>TECHNICAL SUPPORT & SERVICE</p> <p>☎ 80 90 16 50 +49 4621 4210-945 ✉ info@fitshop.dk</p> <p>🕒 Mo - Fr 08:00 - 18:00 Sa 09:00 - 18:00</p>	<p>TECHNICAL SUPPORT & SERVICE</p> <p>☎ +33 (0) 172 770033 +49 4621 4210-933 ✉ service-france@fitshop.fr</p> <p>🕒 Mo - Fr 08:00 - 18:00 Sa 09:00 - 18:00</p>
	PL	BE
	<p>TECHNICAL SUPPORT & SERVICE</p> <p>☎ 22 307 43 21 +49 4621 42 10-948 ✉ info@fitshop.pl</p> <p>🕒 Mo - Fr 08:00 - 18:00 Sa 09:00 - 18:00</p>	<p>TECHNICAL SUPPORT & SERVICE</p> <p>☎ 02 732 46 77 +49 4621 42 10-932 ✉ info@fitshop.be</p> <p>🕒 Mo - Fr 08:00 - 18:00 Sa 09:00 - 18:00</p>

UK	NL	INT
<p>TECHNICAL SUPPORT</p> <p>☎ +44 141 876 3986 ✉ support@powerhousefitness.co.uk</p> <p>SERVICE</p> <p>☎ +44 141 876 3972 🕒 Mo - Fr 9am - 5pm</p>	<p>TECHNICAL SUPPORT & SERVICE</p> <p>☎ +31 172 619961 ✉ info@fitshop.nl</p> <p>🕒 Ma - Do 09:00 - 17:00 Vr 09:00 - 21:00 Za 10:00 - 17:00</p>	<p>TECHNICAL SUPPORT & SERVICE</p> <p>☎ +49 4621 4210-944 ✉ service-int@sport-tiedje.de</p> <p>🕒 Mo - Fr 8am - 6pm Sat 9am - 6pm</p>
	AT	CH
	<p>TECHNICAL SUPPORT & SERVICE</p> <p>☎ 0800 20 20 277 (Freecall) +49 4621 42 10-0 ✉ info@sport-tiedje.at</p> <p>🕒 Mo - Fr 08:00 - 18:00 Sa 09:00 - 18:00</p>	<p>TECHNICAL SUPPORT & SERVICE</p> <p>☎ 0800 202 027 +49 4621 42 10-0 ✉ info@sport-tiedje.ch</p> <p>🕒 Mo - Fr 08:00 - 18:00 Sa 09:00 - 18:00</p>

Please find a detailed overview including address and opening hours for all stores of the Sport-Tiedje Group in Germany and abroad on the following website:

www.sport-tiedje.com/en/stores

WE LIVE FITNESS

WEBSHOP AND SOCIAL MEDIA

Sport-Tiedje is Europe's largest specialist store for home fitness equipment with currently 80 stores and one of the world's most renowned online mail order companies for fitness equipment. Private customers order via the 25 web shops in the respective national language or have their desired equipment assembled on site. In addition, the company supplies fitness studios, hotels, sports clubs, companies and physio practices with professional equipment for endurance and strength training.

Sport-Tiedje offers a wide range of fitness equipment from renowned manufacturers, high-quality in-house developments and comprehensive services, such as a build-up service and sports scientific advice before and after the purchase. The company employs numerous sports scientists, fitness trainers and competitive athletes.

Visit us also on our social media platforms or our blog!

