



Assembly and Operating Instructions



max. 120 kg



~ 30-60 Min.



29 kg

L 108 | W 56 | H 139

FSDFHT40.01.01

DF-HT40

DARWIN HT40

Content

1	GENERAL INFORMATION	8
1.1	Technical Data	8
1.2	Personal Safety	9
1.3	Electrical Safety	10
1.4	Set-Up Place	11
2	ASSEMBLY	12
2.1	General Instructions	12
2.2	Scope of Delivery	13
2.3	Assembly	14
3	OPERATING INSTRUCTIONS	19
3.1	Console Display	19
3.2	Button Function	20
3.3	Turning On and Setting the Equipment	21
3.4	Training programme	22
3.4.1	MANUAL MODE	22
3.4.2	PROGRAM MODE	23
3.4.3	H.R.C. MODE	24
3.4.4	WATT MODE	25
3.4.5	USER PROGRAM MODE	25
3.4.6	RECOVERY	26
3.4.7	BODY FAT	26
4	STORAGE AND TRANSPORT	28
4.1	General Instructions	28
4.2	Transportation Wheels	28
5	TROUBLESHOOTING, CARE AND MAINTENANCE	29
5.1	General Instructions	29
5.2	Faults and Fault Diagnosis	29
5.3	Error Codes and Troubleshooting	30
5.4	Maintenance and Inspection Calendar	30
6	DISPOSAL	30
7	RECOMMENDED ACCESSORIES	31

8	ORDERING SPARE PARTS	32
8.1	Serial Number and Model Name	32
8.2	Parts List	33
8.3	Exploded Drawing	36
9	WARRANTY	37
10	CONTACT	39

Dear customer,

thank you for choosing Darwin Fitness® equipment. With Darwin fitness equipment we offer first class home sports equipment at a great price point. Darwin exercise bikes and strength machines are easy to use, have a space-saving design and look really good. With our equipment we want to support you in reaching your athletic goals, no matter if you want to lose weight or train for the national triathlon. If you have any further questions, please contact us, we are looking forward to hearing from you and wish you lots of fun during your training!

Further information can be found at www.fitshop.com.

Intended Use

The equipment may only be used for its intended purpose.

The equipment is only suitable for home use. The equipment is not suitable for semi-professional (e.g. hospitals, associations, hotels, schools, etc.) and commercial or professional use (e.g. fitness studios).

Legal Notice

Fitshop GmbH
Europe's No. 1 for home fitness

International Headquarters
Flensburger Straße 55
24837 Schleswig
Germany

Management:
Christian Grau
Sebastian Campmann
Dr. Bernhard Schenkel
No. HRB 1000 SL
Local Court Flensburg
European VAT Number: DE813211547

Disclaimer

© Darwin Fitness is a registered brand of the company Fitshop GmbH. All rights reserved. Any use of this trademark without the explicit written permission of Fitshop is prohibited.

Product and manual are subject to change. Technical data can be changed without advance notice.

FITSHOP

Europe's No.1 for Home Fitness

ABOUT THIS MANUAL

Please carefully read the entire manual before installation and first use. The manual will help you to quickly set up the system and explains how to safely use it. Make sure that all persons exercising with the equipment (especially children and persons with physical, sensory, mental or motor disabilities) are informed about this manual and its contents in advance. In case of doubt, responsible persons must supervise the use of the equipment.

Due to ongoing changes and software optimisations, the manual may have to be updated. If you notice any discrepancies during assembly or use, please refer to the manual uploaded to the webshop. The latest manual is always available there.



This equipment has been manufactured according to the latest safety knowledge. As far as possible, potential safety hazards which could cause injury have been eliminated. Make sure to carefully follow the instructions and that all parts are securely in place. If required, read through the instructions again to correct any mistakes.

Training devices must be classified according to accuracy and use. Accuracy classes are only applicable to devices that display training data.

Accuracy classes

Class A: high accuracy.

Class B: medium accuracy.

Class C: low accuracy.

The use classes explain the intended use of the training device.

Use classes

Class S (studio): professional and/or commercial use.

These training devices are intended for the use in training rooms of facilities such as sports clubs, school facilities, hotels, clubs and studios whose access and supervision is specifically regulated by the owner (person with legal responsibility).

Class H (home use): use at home.

These stationary training devices are intended for the use in private homes where access to the training device is regulated by the owner (person with legal responsibility).

Please pay close attention to the safety and maintenance instructions given here. The contract partner cannot be held liable for damage to health, accidents or damage to the equipment when it is not used in accordance with these instructions.

The following safety instructions may appear in this manual:

► **ATTENTION**

This notice indicates potentially hazardous situations which, if not avoided, may result in property damage.

⚠ **CAUTION**

This notice indicates potentially hazardous situations which, if not avoided, may result in slight or minor injuries!

⚠ **WARNING**

This notice indicates potentially hazardous situations which, if not avoided, may result in death or serious injuries!

⚠ **DANGER**

This notice indicates potentially hazardous situations which, if not avoided, will result in death or serious injuries!

ⓘ **NOTICE**

This notice indicates further useful information.

Retain these instructions in a safe place for future reference, maintenance or when ordering replacement parts.

1.1 Technical Data

LCD display of

- + speed in km/h
- + training time in min
- + training distance in km
- + cadence (rotations per minute)
- + calories burnt in kcal
- + heart rate (when using the hand sensors)
- + watt
- + resistance level

Resistance system:	electronically adjustable magnetic brake
Flywheel:	7 kg
Transmission ratio:	32
Watt:	24 - 270 Watt (adjustable in 5 watt steps)

Weight and dimensions:

Product weight (gross, incl. packaging):	33.6 kg
Product weight (net, without packaging):	28.5 kg
Packaging dimensions (L x W x H):	102 cm x 65 cm x 26 cm
Set-up dimensions (L x W x H):	108 cm x 56 cm x 139 cm
Maximum user weight:	120 kg/264 lbs
Use class:	H

1.2 Personal Safety

DANGER

- + Before you start using the equipment, you should consult your physician that this type of exercise is suitable for you from a health perspective. Particularly affected are persons who: have a hereditary disposition to high blood pressure or heart disease, are over the age of 45, smoke, have high cholesterol values, are overweight and/or have not exercised regularly in the past year. If you are under medical treatment that affects your heart rate, medical advice is absolutely essential.
- + Note that excessive training can seriously endanger your health. Please also note that heart rate monitoring systems can be inaccurate. If you notice any signs of weakness, nausea, dizziness, pain, shortness of breath, or other abnormal symptoms, stop exercising immediately and seek advice from your doctor if necessary.
- + The owner must communicate all warnings and instructions to the user.

WARNING

- + This equipment may not be used by children under the age of 14.
- + Children should not be allowed unsupervised access to the equipment.
- + Persons with disabilities must have a medical license and must be under strict observation when using the equipment.
- + The equipment is strictly for use by one person at a time.
- + If your equipment provides a safety key, the clip of the safety key must be attached to your clothing before starting your training. In the event of a fall, the EMERGENCY STOP of the equipment can be initiated.
- + There is a risk of injury from spinning pedals and/or an exposed flywheel in the absence of a freewheel. Never get on or off the equipment when the pedals or the flywheel are still moving. Always make sure that the pedals and the flywheel have come to a complete stop.
- + Support yourself with at least one hand on the handlebar when getting on and off the equipment. Only dismount from the equipment when the pedals have come to a complete stop.
- + Keep your hands, feet and other body parts, hair, clothing, jewellery and other objects well clear of moving parts.
- + During use, wear suitable sports clothing rather than loose or baggy clothing. When wearing sports shoes, make sure they have suitable soles, preferably made of rubber or other non-slip materials. Shoes with heels, leather soles, studs or spikes are unsuitable. Never exercise barefoot.

CAUTION

- + If your equipment needs to be connected to the power supply with a mains cable, make sure that the cable is not a potential tripping hazard.
- + Make sure that nobody is within the range of motion of the equipment during training so as not to endanger you or other persons.
- + Always tighten the pedal strap before you start training to prevent your feet from slipping.

⚠ CAUTION

- + Be aware that if adjustment devices are left protruding, they may impede the user's movement.

▶ ATTENTION

- + Do not insert any objects of any kind into the openings of the device.
- + To protect the equipment from use by unauthorised third parties, always remove the power cable (if existing) when not in use and store it in a safe place that is inaccessible to unauthorised persons (e.g. children).
- + Class B and C crank training equipment is not suitable for high accuracy purposes.

1.3 Electrical Safety

⚠ DANGER

- + In order to reduce the risk of an electric shock, always unplug the equipment from the mains socket immediately after your workout, before assembly or dismantling, and before maintenance or cleaning. Do not pull on the cable.

⚠ WARNING

- + Do not leave the equipment unattended while the mains cable is plugged into the mains socket. During your absence, the mains cable must be removed from the mains socket to prevent improper use by third parties or children.
- + If the mains cable or plug is damaged or defective, contact your contract partner. Until repair, the equipment must not be used.

▶ ATTENTION

- + The equipment requires a mains connection of 220-230 V with 50 Hz mains voltage.
- + The equipment may only be connected directly to an earthed socket using the supplied mains cable. Extension cables must conform to VDE guidelines. Always completely unwind the mains cable.
- + The socket must be protected by a fuse with a minimum fuse rating of "16 A, slow blow".
- + Do not make any changes to the mains cable or the mains plug.
- + Keep the mains cable away from water, heat, oil and sharp edges. Do not route the mains cable underneath the equipment or under a carpet or rug, and do not place any objects on top of it.
- + If your purchased item is equipped with a TFT console, software updates must be carried out regularly. Follow the instructions on the console to perform the update(s).
- + The software systems on gym equipment with TFT consoles are set up only for the pre-installed apps. Do not install any additional apps.

ⓘ NOTICE

- + The pre-installed apps on TFT consoles are produced and provided by external manufacturers. Fitshop does not take any responsibility for the availability, functionality or contents of these apps.

1.4 Set-Up Place

WARNING

- + Do not place the equipment in main corridors or escape routes.

CAUTION

- + Choose a location in which to place the equipment such that there is enough free space/clearance to the front, the rear and to the sides of the equipment.
- + The training room should be well ventilated during training and not be exposed to any draughts.
- + Choose the place in which to set up the equipment such that there is enough free space/clearance to the front, the rear and to the sides of the equipment.
- + The free area in the direction from which the exercise equipment is accessed must be at least 0.6 m larger than the exercise area.
- + The set-up and mounting surface of the equipment should be flat, loadable and solid.

ATTENTION

- + The device may only be used in one building, in sufficiently tempered and dry rooms (ambient temperatures between 10°C and 35°C). The equipment should not be used outdoors or in rooms with high humidity (over 70%) like swimming pools.
- + A floor protective mat/equipment underlay can help to protect high-quality floor coverings (parquet, laminate, cork, carpets) from dents and sweat and can help to level out slight unevenness.
- + For Class S equipment, the exercise equipment may only be used in areas where access, supervision and control are specifically regulated by the owner.

2.1 General Instructions



DANGER

- + Do not leave any tools, packaging materials such as foils or small parts lying around, as otherwise there is a danger of suffocation for children. Keep children away from the equipment during assembly.



WARNING

- + Pay attention to the instructions attached to the equipment in order to reduce the risk of injuries.



CAUTION

- + Do not open the packaging when it is lying on its side.
- + Ensure to have sufficient room for movement in each direction during assembly.
- + The assembly of the equipment must be carried out by at least two adults. If in doubt, seek the help of another technically skilled person.



ATTENTION

- + To prevent damage to the equipment and the floor, assemble the equipment on a mat or packaging board.



NOTICE

- + In order to make the assembly as simple as possible, some screws and nuts to be used can already be pre-assembled.
- + Ideally, assemble the equipment at its later set-up place.

2.2 Scope of Delivery

The scope of delivery consist of the following parts. At the beginning, check whether all parts and tools belonging to the device are included in the scope of delivery and whether damage has occurred. In the event of complaints, the contractual partner must be contacted directly.

CAUTION

If parts of the scope of delivery are missing or damaged, the assembly must not be carried out.

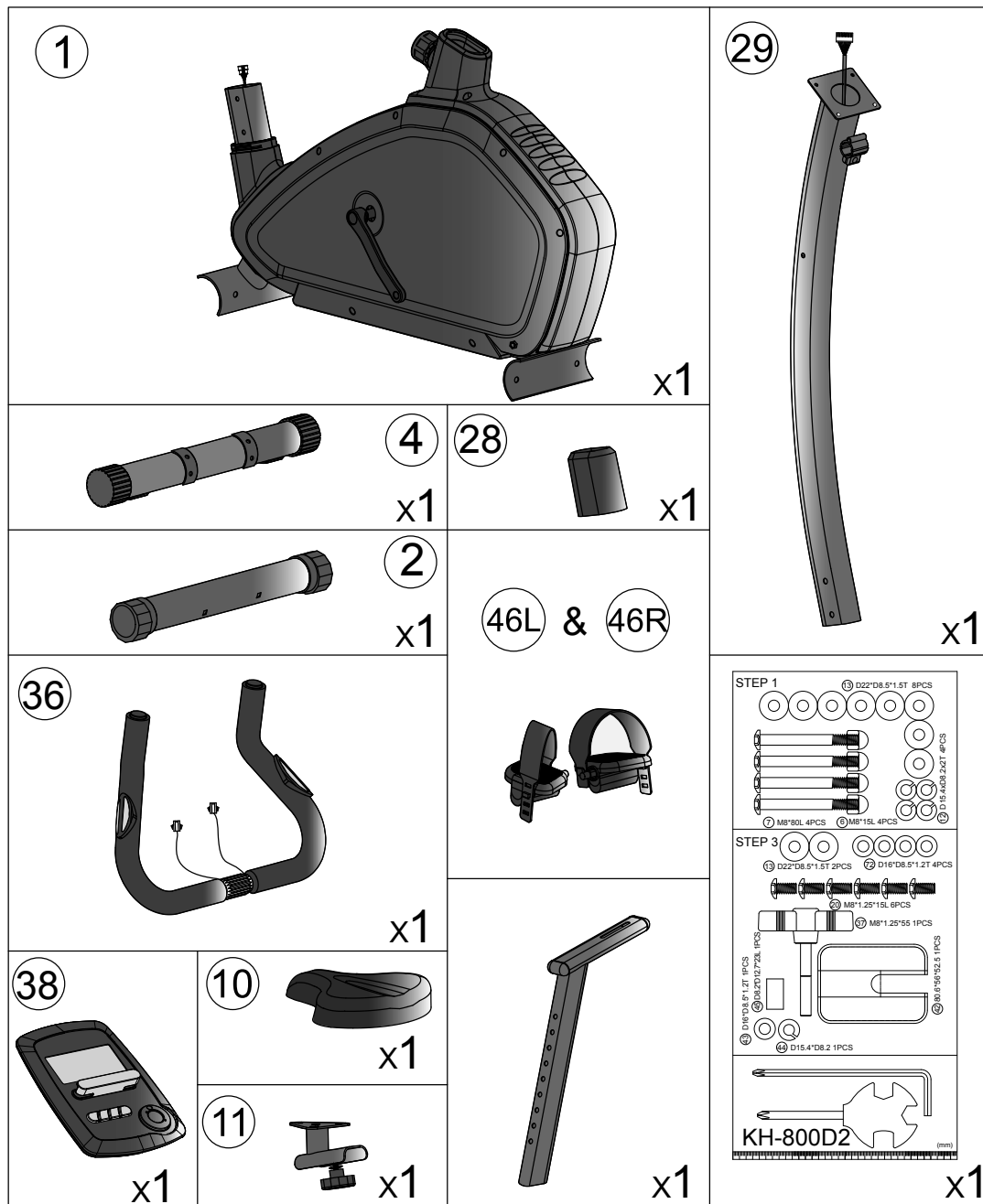

2.3 Assembly

Before assembly, take a close look at the individual assembly steps shown and carry out the assembly in the order given.

① NOTICE

- + First loosely screw all parts together and check that they fit properly. Tighten the screws using the tool only when you are instructed to do so.
- + If you have difficulty recognising the graphics, we recommend that you open and/or download the PDF instructions stored in the webshop on your end device (e.g. smartphone, tablet or PC). There you have the option of zooming in closer. Please note that the Adobe Acrobat Reader programme must be installed on your end device in order to open the file.
- + The assembly can also be found as a video under the following link: <https://www.sport-tiedje.co.uk/darwin-exercise-bike-ht40-df-ht40#product-assembly>. To go directly to the assembly video, you can alternatively scan the QR code.



Step 1: Assembly of base

1. Mount the front base (4) and the rear base (2) with a cap nut (6), an Allen screw (7), a spring washer (12), and a curved washer (13) on the main frame (1).
2. Adjust the appropriate height by turning the wheel on the rear foot cap.

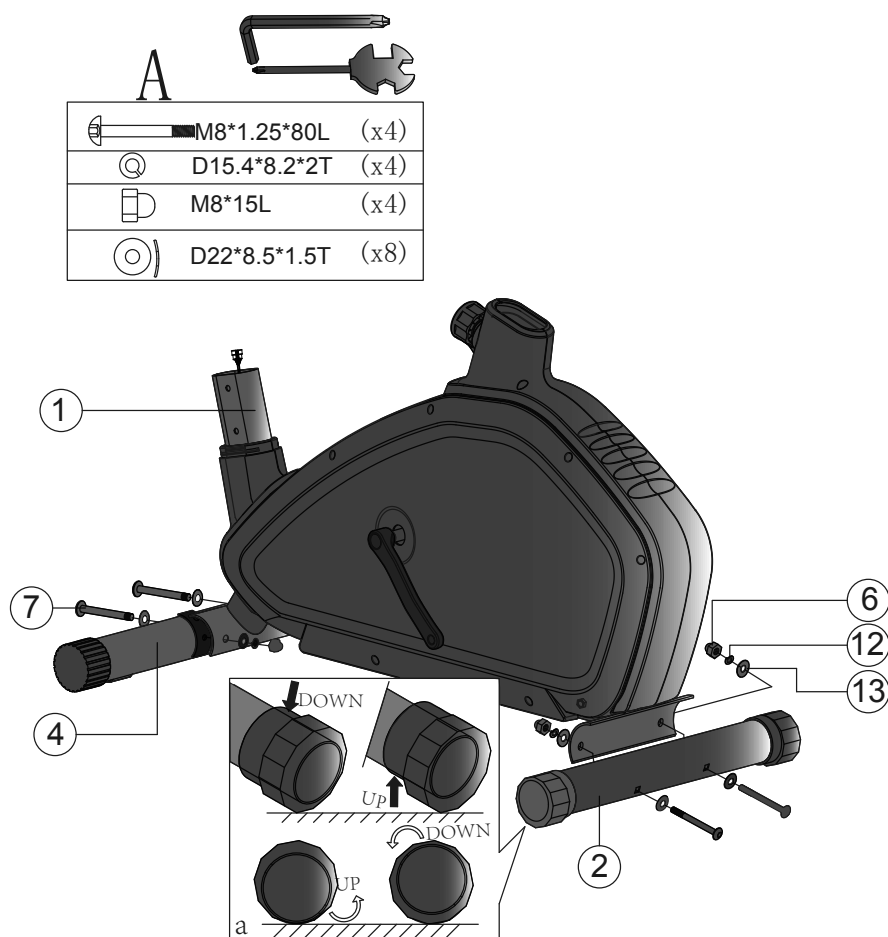

Step 2: Assembly of saddle and seat tube

1. Mount the seat (10) with a washer (17) and a control knob (18) on the seat post (9).
2. Mount the seat post (9) with a control knob (31) on the main frame (1).
3. Adjust the saddle in vertical and horizontal direction.

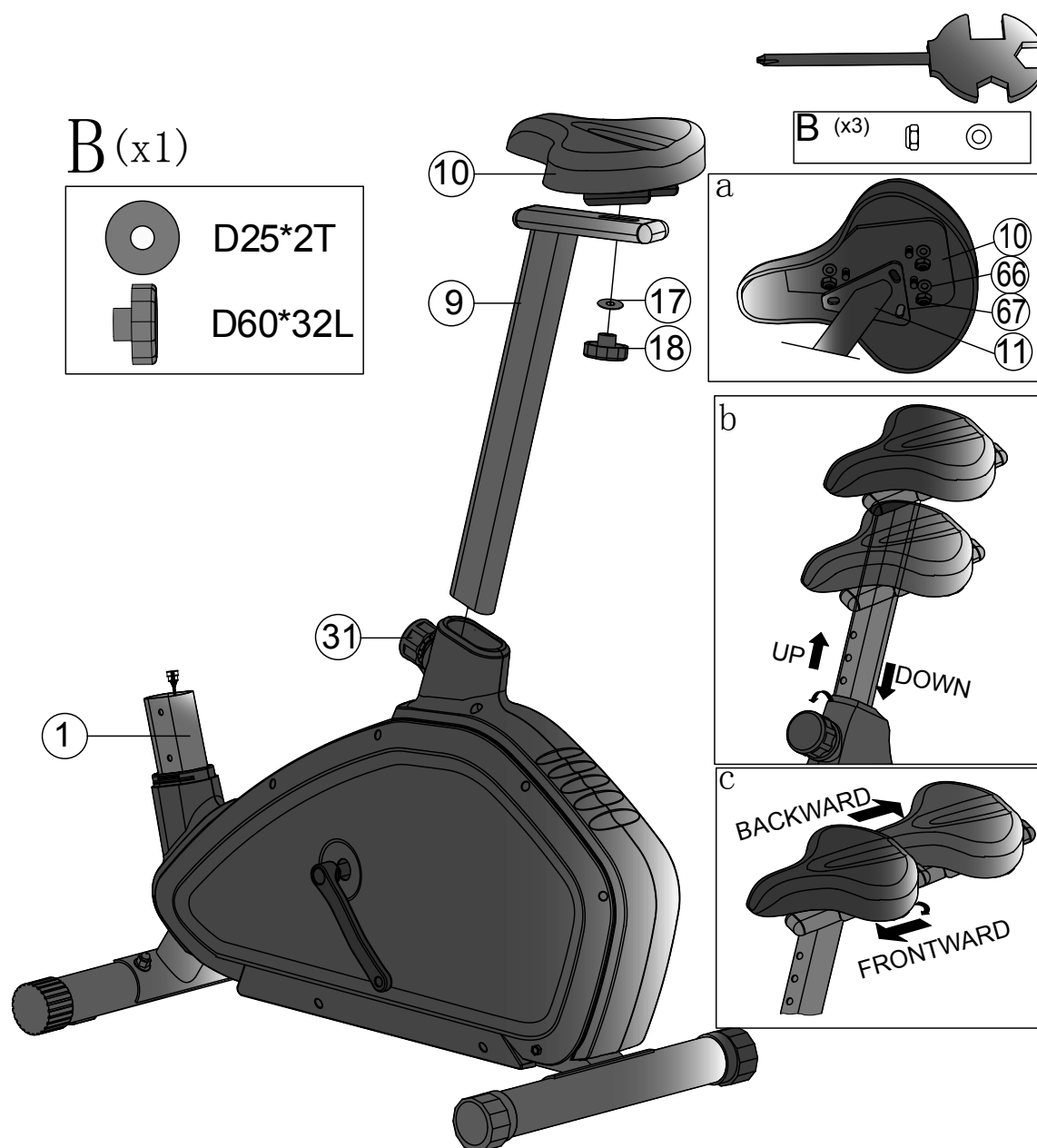

Step 3: Assembly of upright post and console post

⚠ CAUTION

It is recommended to do this assembly step with two persons.

1. At first, you lift the upper protective cover (28), see figure (a). Then you connect the computer cables (64 & 65), see figure (b).
2. Slide the handlebar post (29) on the main frame and mount it with a curved washer (13), an Allen screw (20), and a washer (72). Mount the protective cover back on the main frame.
3. Mount the handlebar (36) on the handlebar post (29) with the protective cover (42), a washer (43), a spring washer (12), a bushing (45), and a ball-shaped control knob (37).

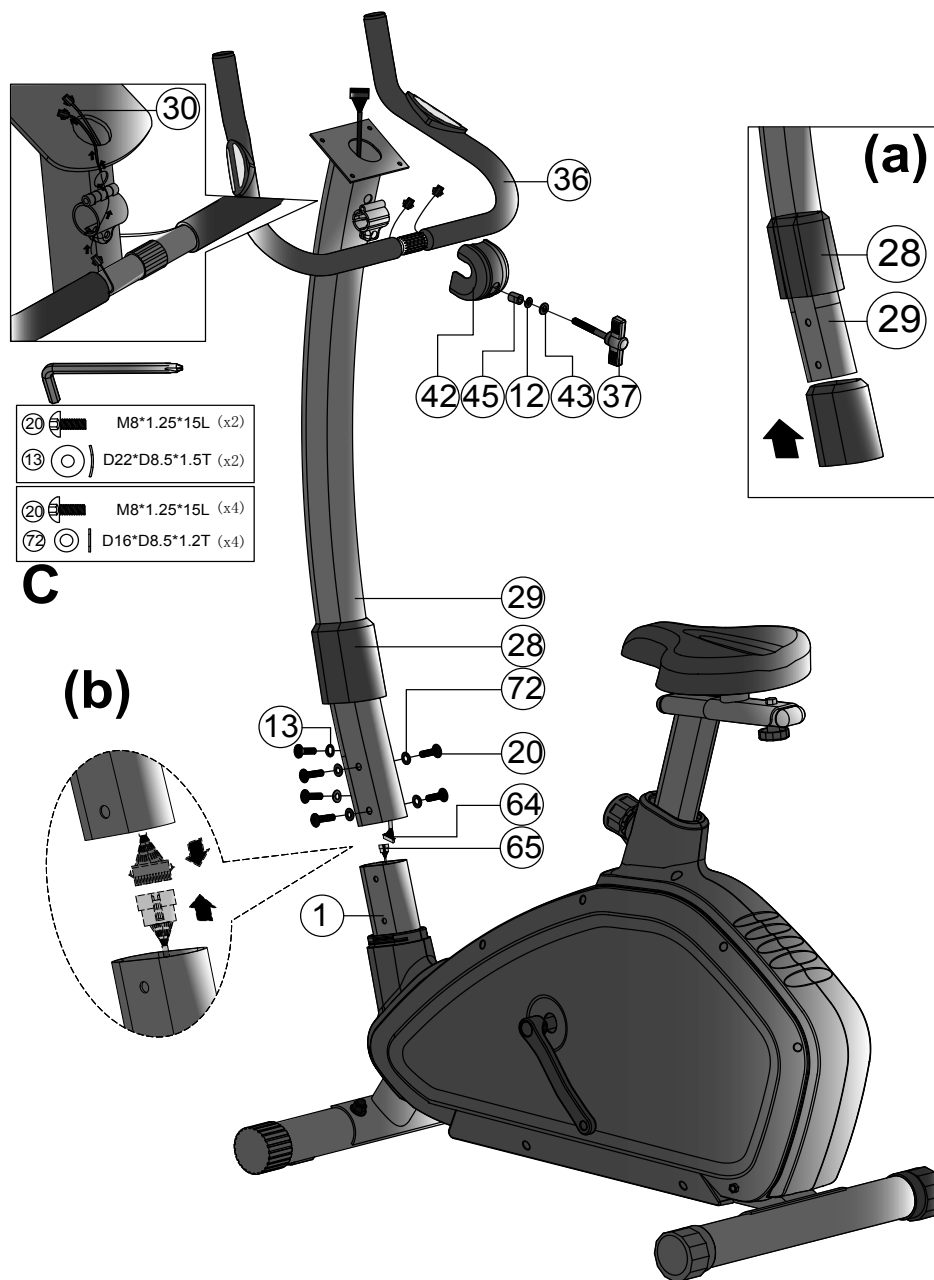

Step 4: Mounting the console and the pedals

1. Connect the upper computer cable (64) and the hand pulse cable (30) with the computer (38). Mount the computer (38) with a screw (59) on the handlebar post (29).



CAUTION

Make sure to screw in the pedals completely.

2. Screw the left pedal (36L) counter-clockwise on the left crank (35L) and the right pedal (36R) clockwise on the right crank (35R).

Step 5: Connecting the equipment to the mains supply



ATTENTION

The equipment must not be connected to a multiple socket, otherwise it cannot be guaranteed that the equipment will be supplied with sufficient power. Technical errors can result.

Plug the power plug (54) into a wall outlet that complies with the instructions in the chapter on electrical safety.

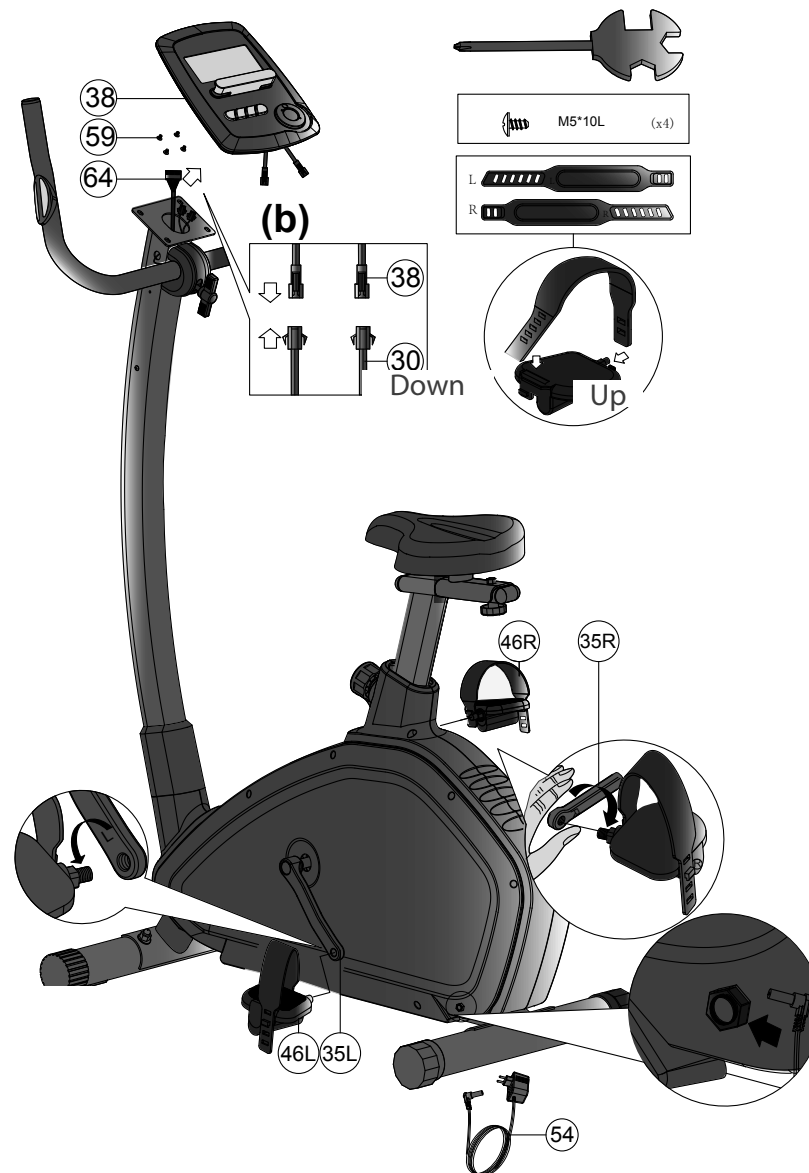

Correctly Getting On and Off

1. To get on, grip the handles with both hands and first step onto the left pedal with your left foot or onto the right pedal with your right foot and then place your foot onto the other pedal.
2. To get off, grip the handles with both hands and place one foot next to the equipment and then the other foot.

3 OPERATING INSTRUCTIONS

① NOTICE

- + Familiarise yourself with all the functions and setting options of the device before starting training. Have the proper use of this product explained to you by a specialist.
- + Always start your training with low intensity and increase evenly and gently. End your training with a cool-down phase. If you are unsure, please consult your physician.

3.1 Console Display



Time	When no target is set, the time counts up from 00:00 to a maximum of 99:59. When you work out with a pre-set time, the time counts from the pre-set time down to 00:00. Every pre-set increment is one minute from 00:00 to 99:00.
Speed	Displays the current training speed from 00.0 to 99.9 km/h or mph.
RPM	Displays the rotations per minute. RPM range: 0 – 15 – 999.
Distance	Counts the distance from 0.00 to 99.99 km or miles. A target value for the distance can be set with the UP/DOWN buttons. The desired distance can be set from 0.00 to 99.99 in increments of 0.1 km or miles.
Calories	Counts the calorie consumption during the training from 0 to a maximum of 9999 calories. (These data serve as rough guide for comparing different training sessions. However, it cannot be used for medical treatment.)

Pulse	A target value for pulse can be set from 30 to 230. A signal sounds on the computer, when the current heart rate exceeds the target heart rate during the training.
Watts	Displays the current Watt of the training. Watt range: 0 to 999. In the Watt controlled mode, the Watt value can be set from 25 to 270.
Manual	Manual training mode.
Program	Select from 12 programmes.
User Program	Create and save your own profile programme.
H.R.C.	Target heart rate training mode.
Watt Program	Watt programme, the resistance is adjusted according to your pedalling speed, so that you train at a constant performance (Watt). The quicker you pedal, the lower is the resistance.

3.2 Button Function

+ (Jog dial)	Turn right to increase the resistance level and values and to select a programme.
- (Jog dial)	Turn left to reduce the resistance level and values and to select a programme.
MODE (Jog dial)	Press to confirm setting or selection.
RESET	<ul style="list-style-type: none"> + Press and hold for two seconds to reboot the computer and to start with the user settings. + Press shortly to return to the Stop mode or enter the training values in the main menu.
START/STOP	Press to start or pause the training (stop mode).
RECOVERY	Press to test the heart rate recovery pulse.
BODY FAT	In stop mode, press to measure the body fat.

3.3 Turning On and Setting the Equipment

1. Plug the adapter in the socket and the computer turns on. It displays all segments on the LCD screen for two seconds (fig. 1).
2. Then you start setting the user data.
3. Select U1 to U4 with the jog dial and confirm with MODE.
4. Enter your gender, age, height (fig. 2), and weight with the jog dial and confirm each setting with MODE.

When you have entered the profile of the user data, the console switches to the main menu (fig. 3).

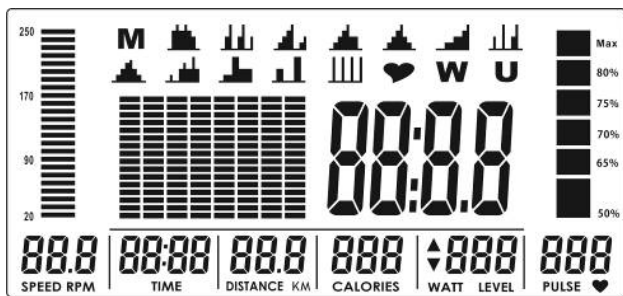

Fig. 1

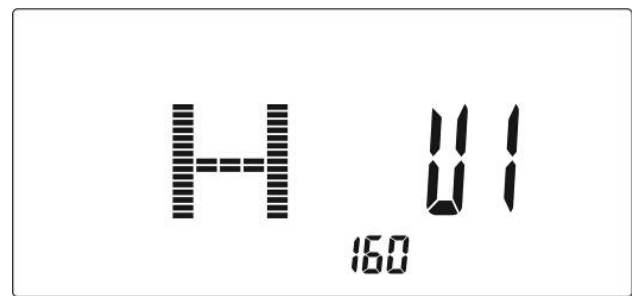

Fig. 2

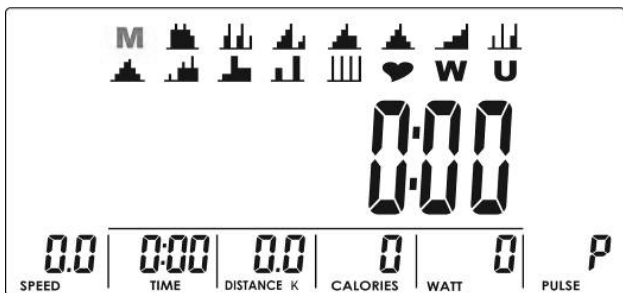

Fig. 3

3.4 Training programme

Select one of the training programmes with the jog dial: M (Manual) + P (Programme 1 to 12) + H.R.C. (heart rate controlled) + W (Watts) + U (User). Confirm the selected programme with MODE.

3.4.1 MANUAL MODE

Press START in the main menu to start directly the training in the manual mode.

1. Select the training programme M with the jog dial and confirm with MODE.
2. Set the resistance level with the jog dial (fig. 4) and confirm with MODE. The default value is 1.
3. Enter the values for training time (fig. 5), distance (fig. 6), calories (fig. 7) and pulse (fig. 8) with the jog dial and confirm each setting with MODE.
4. Press START/STOP to start the training. During the training, the resistance level can be adjusted with the jog dial. When the resistance level is displayed in the WATT window, the value cannot be adjusted for three seconds. It switches to the display WATT (fig. 9).
5. Press START/STOP to pause the training. Press RESET to return to the main menu.

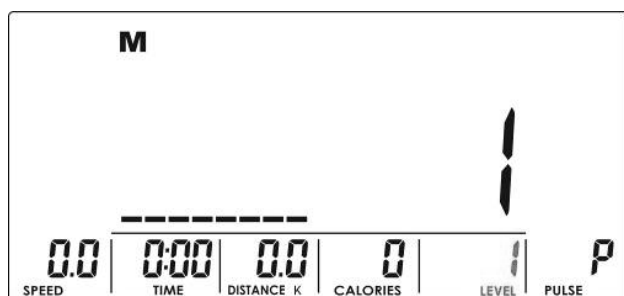

Fig. 4

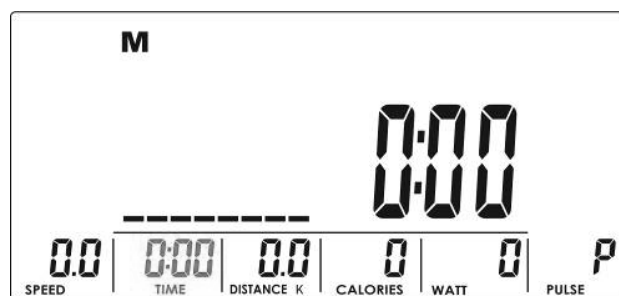

Fig. 5

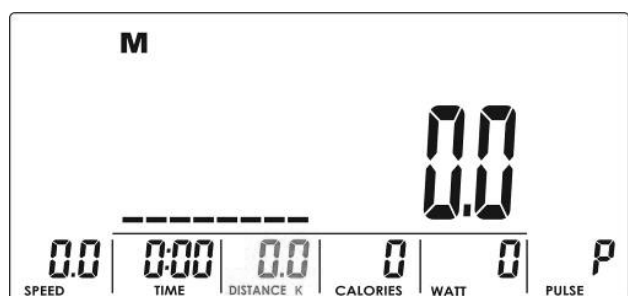

Fig. 6

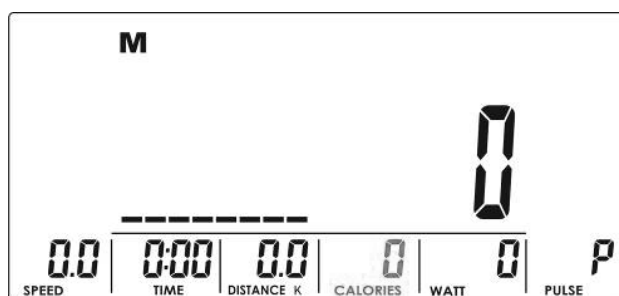

Fig. 7

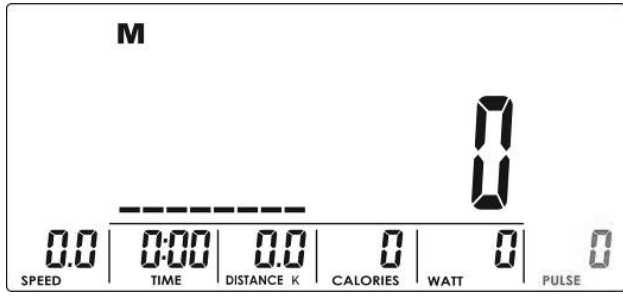

Fig. 8

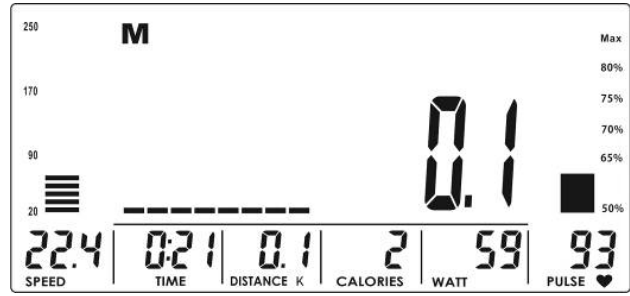

Fig. 9

3.4.2 PROGRAM MODE

1. Select the training programme P with the jog dial. Select one of the preset profiles P01, P02, P03, etc. and confirm with MODE.
2. Set the resistance level with the jog dial (fig. 10) and confirm with MODE. The default value is 1.
3. Set the training time with the jog dial and confirm with MODE.
4. Press START/STOP to start the training. During the training, the resistance level can be adjusted with the jog dial.
5. Press START/STOP to pause the training. Press RESET to return to the main menu.

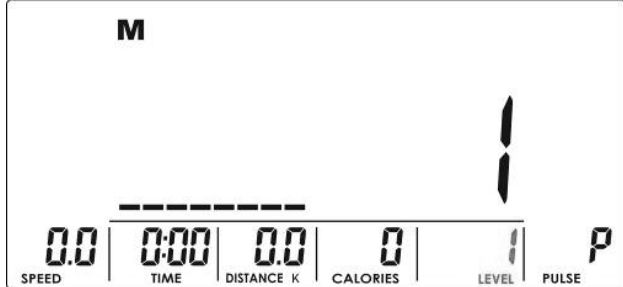

Fig. 10

3.4.3 H.R.C. MODE

WARNING

Your training equipment is not a medical device. The heart rate measurement of this equipment may be inaccurate. Various factors can affect the accuracy of the heart rate measurement. The heart rate measurement serves only as a training aid.

1. Select the H.R.C. training programme with the jog dial and confirm with MODE.
2. Select 55 % (fig. 11), 75 % (fig. 12) 90% (fig. 13) or TAG (target heart rate, default value: 100) (fig. 14) with the jog dial and confirm with MODE. If you have selected TAG, now set a value from 30 to 230 with the jog dial and confirm with MODE.
3. Set the training time with the jog dial and confirm with MODE.
4. Press START/STOP to start or pause the training. Press RESET to return to the main menu.

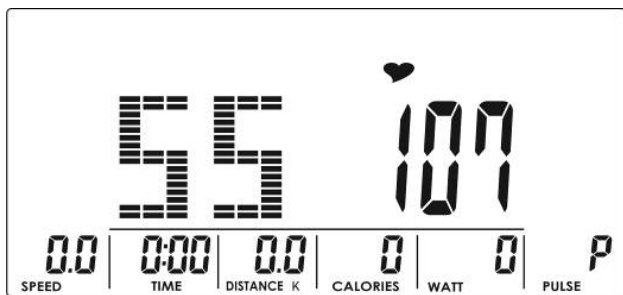

Fig. 11

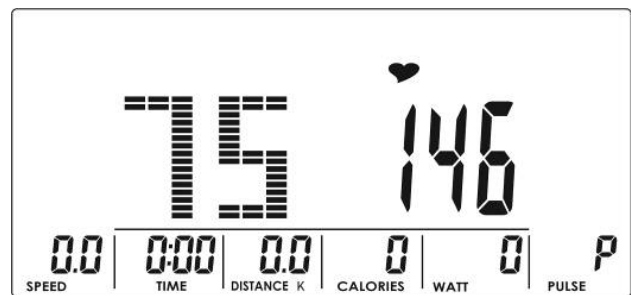

Fig. 12

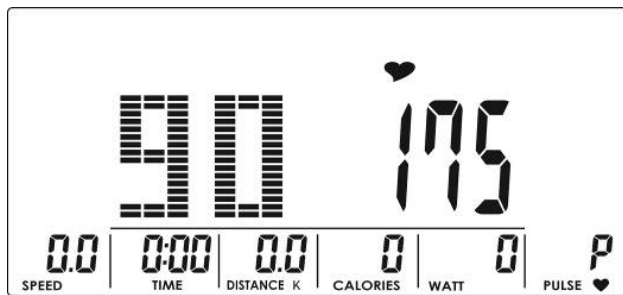

Fig. 13

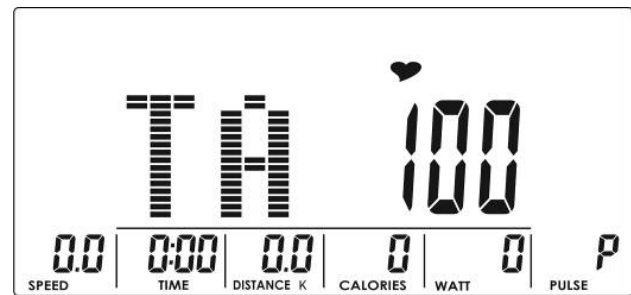

Fig. 14

3.4.4 WATT MODE

1. Select the training programme W with the jog dial and confirm with MODE.
2. Set the WATT target (default value: 120, fig. 15) with the jog dial and confirm with MODE.
3. Set the training time with the jog dial and confirm with MODE.
4. Press START/STOP to start the training. During the training, the system adjusts automatically the resistance level according to the pedalling speed to keep the wattage (resistance) constant. The target Watt value can be adjusted during training with the jog dial.
5. Press START/STOP to pause the training. Press RESET to return to the main menu.

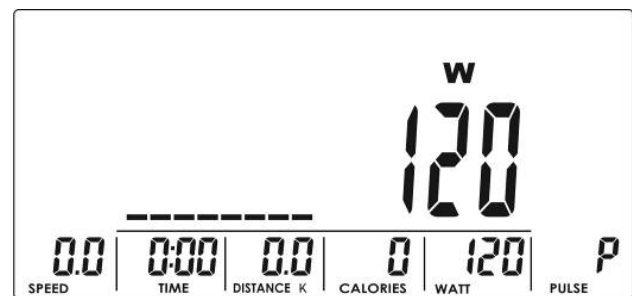

Fig. 15

3.4.5 USER PROGRAM MODE

1. Select the training programme U with the jog dial and confirm with MODE.
2. Create an individual profile programme (fig. 16) by setting the resistance levels for each of the eight segments with the jog dial and confirming each entry with MODE. Press MODE for two seconds to finish it during the setting.
3. Set the training time with the jog dial and confirm with MODE.
4. Press START/STOP to start the training. During the training, the resistance level can be adjusted with the jog dial.
5. Press START/STOP to pause the training. Press RESET to return to the main menu.



Fig. 16

3.4.6 RECOVERY

After the training, press RECOVERY. Grab the handles with both hands or wear a compatible chest strap. The display of all functions is stopped except for TIME. The time starts to count down from 00:60 to 00:00 (fig. 17). The screen displays your heart rate recovery state from F1 to F6 (fig. 18). F1 stands for the best value, F6 stands for the worst. Continue exercising to improve your heart rate recovery state. (Press RECOVERY again to return to the main display.)



Fig. 17



Fig. 18

3.4.7 BODY FAT

1. Press BODY FAT in the stop mode to start the measuring of your body fat.
2. The console displays UX (fig. 19) and starts to measure (fig. 20 to 21).
3. Hold the handles with both hands during the measuring. Once the console has detected the pulse, the LCD screen displays === for eight seconds (fig. 22) until the measuring is finished.
4. The LCD screen displays the BMI (fig. 23), the fat percentage (FAT %, fig. 24), and the body fat symbol (BODY FAT, fig. 25).

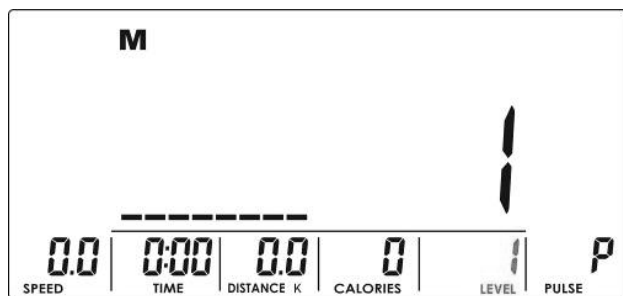

Fig. 19

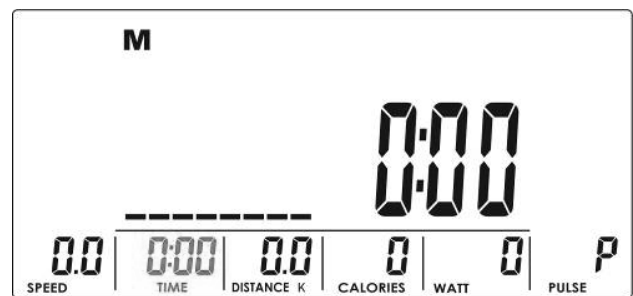

Fig. 20

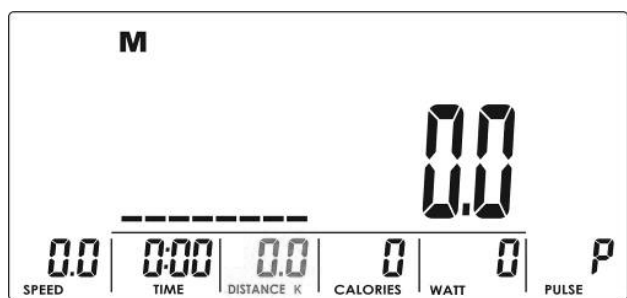

Fig. 21

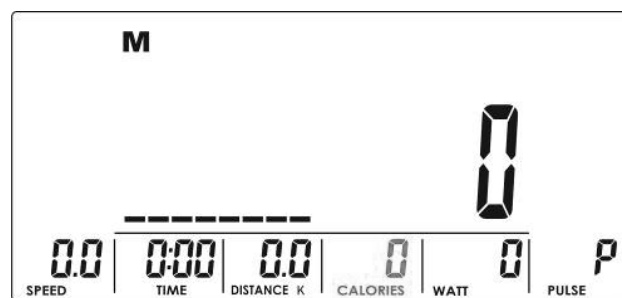

Fig. 22

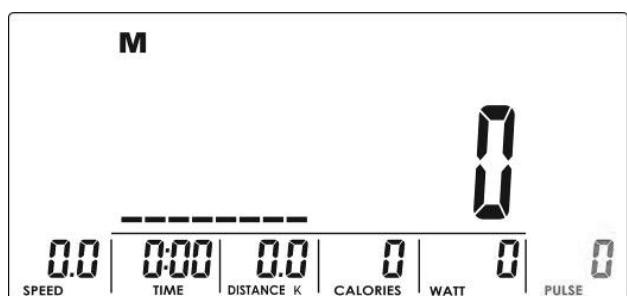

Fig. 23

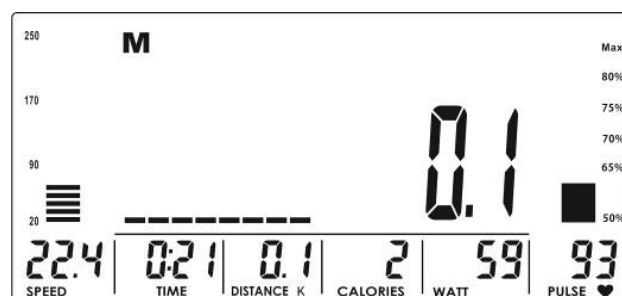

Fig. 24

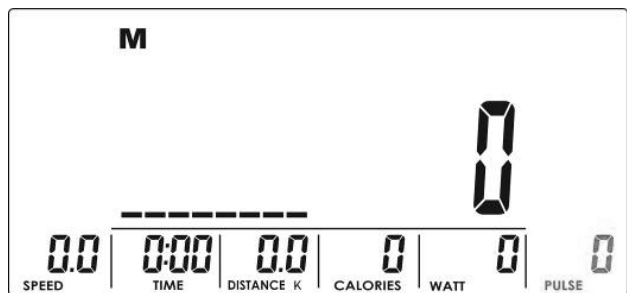

Fig. 25

① **NOTICE**

- + After 4 minutes without pedaling or pulse input, console will enter into power saving mode. Press any key may wake the console up.
- + When computer act abnormal, please plug out the adaptor and plug in again.

4.1 General Instructions

► **ATTENTION**

- + Make sure that the equipment is protected from moisture, dust and dirt in the selected storage location. The storage location should be dry and well ventilated and have a constant ambient temperature between 5°C and 45°C.

⚠ **WARNING**

- + The storage location should be chosen so that improper use by third parties or children can be prevented.
- + If your equipment does not have transportation wheels, the equipment must be disassembled before transportation.

4.2 Transportation Wheels

► **ATTENTION**

If you want to transport your equipment over particularly sensitive and soft floor coverings, such as parquet, planks or laminate, lay out the transport route with cardboard or similar to avoid possible floor damage.

1. Stand behind the equipment and lift it until the weight is transferred to the transportation wheels. After that, you easily can move the equipment to a new position. For long transport distances the equipment should be disassembled and safely packed.
2. Select the new location by following the instructions in the section 1.4 of this manual.

5.1 General Instructions



WARNING

+ Do not make any improper changes to the equipment.



CAUTION

+ Damaged or worn components may affect your safety and the life of the equipment. Therefore, immediately replace damaged or worn components. In such a case, contact the contract partner. The equipment must not be used until it has been repaired. If necessary, use only original spare parts.



ATTENTION

+ In addition to the instructions and recommendations for maintenance and care given here, additional service and/or repair work may be necessary; this must only be carried out by authorised service technicians.

5.2 Faults and Fault Diagnosis

The equipment undergoes regular quality controls during production. Nevertheless, faults or malfunctions may occur. Frequently, individual parts are responsible for these disturbances, an exchange is usually sufficient. Please refer to the following overview for the most common errors and how to correct them. If the equipment still does not function properly, contact your contract partner.

Fault	Cause	Solution
Crackling noise in pedal area	Loose pedals	Tighten the pedals
Equipment wobbles	Equipment is not level	Adjust the supporting feet
Handlebar/saddle wobbles	Screws are loose	Tighten screws
Display does not turn on	Battery is low* or the cable connection is loose	Change batteries* or check cable connections
No pulse display	+ Sources of interferences in the room + Cable connections are loose + Condition of hands	+ Eliminate these sources (i. e. mobile, loudspeakers, etc.) + Check cable connections + Check pulse measuring with other persons

*If available.

5.3 Error Codes and Troubleshooting

The electronics of the equipment continuously carries out tests. In case of deviations, an error code appears on the display and normal operation is stopped for your safety.

- + The display shows === + The handles are not correctly grasped with both hands.
- + E1 + There is no heart rate signal.
- + E4 + It is displayed, when the values of FAT % and BMI are less than 5 or higher than 50.

Please contact Sport-Tiedje for technical support.

5.4 Maintenance and Inspection Calendar

To avoid damage from body sweat, the equipment must be cleaned with a damp towel (no solvents!) after each training session.

The following routine tasks must be performed at the specified intervals:

Part	Weekly	Monthly	Quarterly	Half-yearly	Yearly
Display console	C	I			
Plastic covers	C	I			
Screws and cable connections		I			
Check pedals for tightness		I			
Legend: C = clean; I = inspect					

6 DISPOSAL

At the end of its operational life, this equipment cannot be disposed of in normal household waste. Instead, it must be disposed of via an electricals recycling centre. Further information can be obtained from your local authority's recycling service.

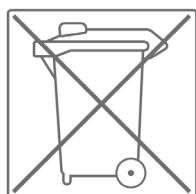

The materials can be recycled as per their symbols. Through the reuse, recycling of materials or other forms of recovery of old equipment, you make an important contribution to the protection of the environment.

To make your training experience even more efficient and pleasant, we recommend that you add suiting accessories to your fitness equipment. For exercise bikes this could for example be a **floor mat**, which makes your fitness equipment stand more securely and also protects the floor from sweat or **silicone spray** to keep moving parts in good shape. For many exercise bikes it is possible to replace the **saddle** or **pedals**, as these are usually the same mounts used on bicycles.

If you have purchased a fitness machine with pulse training and want to train your heart rate, we strongly recommend that you use a compatible **chest strap**, as this ensures optimum transmission of the heart rate.



Our range of accessories offers the highest quality and makes training even better. If you would like to find out more about compatible accessories, please go to the detail page of the product in our webshop (the easiest way is to enter the article number in the search field above) and go to the recommended accessories on this page. Alternatively, you can use the QR code provided. Of course, you can also contact our customer service: by telephone, e-mail, in one of our branches or via our social media channels. We will be happy to advise you!



floor mat



chest strap



chest strap contact gel



saddle



silicone spray

8.1 Serial Number and Model Name

In order to provide you with the best possible service, please have the model name, article number, serial number, exploded drawing and parts list ready. The corresponding contact options can be found in chapter 10 of this operating manual.

NOTICE

The serial number of your equipment is unique. It's located on a white sticker. The exact position of this sticker is shown in the following illustration.



Enter the serial number in the appropriate field.

Serial number:

Brand / Category:

Darwin Fitness / ergometer

Model Name:

HT40

Article Number:

DF-HT40

8.2 Parts List

No.	Name	Specification	Qty.
1	Main frame	800A1-3-1000-J0	1
2	Rear stabilizer	16100-6-2101-J1	1
3	Adjustable cap	55450-5-0060-B1	2
4	Front stabilizer	19000-6-2101-J5	1
5	round foot cap	55443-1-0060-B3	2
6	Domed nut M8x1.25x15L	55208-6-2015-FA	4
7	Allen bolt M8*1.25*80L	50308-5-0080-F3	4
8	Oval cap	55328-3-2550-B1	2
9	Seat post	195S0-3-2200-J3	1
10	Seat DD3532	58001-6-1019-B0	1
11	Seat adjustment tube sets	70104-3-4000-J0	1
12	Spring washer D15.4 XD8.2x2T	55108-2-1520-FA	4
13	Curved washer D22*D8.5*1.5T	55108-3-2215-FA	10
14	semi-round moving foot cap	55454-K-0060-B1	2
15	cross screw ST4x1.41x12L	52804-2-0012-D0	4
16	Foam D20*7T*530L	58015-6-1113-B0	2
17	Flat washer D28xD8.5x3T	55108-1-2830-FA	1
18	Club knob D60x32L(M8x1.25)	52008-2-0022-B0	1
19	Round cap D7/8"x17L	553D7-1-0017-B1	2
20	Allen bolt M8*1.25*15L	50308-5-0015-F0	6
21	Belt	58004-6-1065-00	1
22	Waved washer D22*D17*0.3T	55117-5-2203-DA	2
23	Flat washer D23*D17.2*1.5T	55117-1-2315-NA	1
24	Flywheel set	800A1-2-3100-00	1
25	Left chain cover	800A1-6-4501-B0	1
26	Right chain cover	80002-6-4502-B0	1
27	Belt wheel	58008-6-1012-05	1
28	Oval manhead	19500-6-4578-B0	1
29	Handlebar post sets	800B2-3-2000-J0	1
30	Hand pulse	16800-6-2478-00	2
31	Knob	52716-2-0024-B1	1
32	Sensor cable	195E5-6-2576-00	1
33	Screw cover	81502-6-2779-B0	2

34	hex Bolt M8x1.25x25	50108-2-0025-U0	2
35L	Left crank	58007-6-1045-02	1
35R	Right crank	58007-6-1046-02	1
36	Handlebar	67900-6-2401-C0	1
37	T Knob	51908-2-0055-B1	1
38	Computer SM-1304E-31	800D2-6-2501-B0	1
39	Power cable	70502-6-2596-00	1
40	buffer pad	800B1-6-1081-B0	4
41	cross screw ST4*20	50904-2-0020-D0	2
42	Protective cover	69100-6-2481-B0	1
43	Flat washer D16xD8.5x1.2T	55108-1-1612-FA	1
44	pulse cable	695M0-6-2479-00	2
45	bushing D8xD12.7x23	58002-6-1033-F2	1
46L/46R	Pedal set	58029-6-1026-B0	1
47	C-clip S-17(1T)	55517-1-0010-00	1
48	Nylon nut M6x1.0x6T	55206-1-2006-CA	4
49	hex Bolt M6x1.0x15L	50106-5-0015-C0	4
50	Idle wheel	745S0-6-1671-00	1
51	Nylon nut M10x1.5x10T	55210-1-2010-NA	1
52	Crank axle sets	19802-3-2903-01	1
53	Anti-loosen nut 3/8"-26UNF*6.5T	18600-6-3175-N1	2
54	Adaptor	804C2-6-2584-01	1
55	Bearing #6003ZZ	58006-6-1018-00	2
56	Pin	71600-6-4586-60	2
57	Nylon nut M8*1.25*8T	55208-1-2008-NA	2
58	Fixing plate for idle wheel	195S0-3-1600-N2	1
59	cross Screw M5x0.8x10L	52605-2-0012-F0	4
60	hex Nut M8*1.25*6T	55208-2-2006-NA	1
61	Round magnet	174R4-6-2574-00	1
62	cross Screw ST4.2x1.4x20L	53342-2-0020-N0	10
63	Bushing D22.5*D17.2*6.4T	80700-6-2781-00	1
64	Upper computer cable 1000L	73002-6-2572-00	1
65	Lower computer cable 900L	738A2-6-2573-00	1
66	Flat washer D16xD8.5x1.2T	55108-1-1612-NA	3
67	nylon nut	55208-1-2008-NA	3

68	spring	58003-6-1024-N0	1
69	Cross bolt M5x0.8x12L	52605-2-0012-N0	1
70	Hollow end cap 40x80x129	55302-6-4080-B2	1
71	Bolt cover	19100-6-3172-B0	2
72	Flat washer D16*D8.5*1.2T	55108-1-1612-FA	4
73	Tension cable D1.5*460L	801E2-6-2601-00	1
74	Motor	73002-6-2571-00	1
75	cross screw ST4.2*1.4*15L	53342-2-0015-N0	4
76	xx	XX	X
77	xx	XX	X
78	Plastic washer D50*D10*1.0T	55110-1-5010-BF	1
79	Flat washer D30*D8.5*2.0T	55108-1-3020-NA	1
80	hex Bolt M8*25	50108-5-0025-N3	1
81	Plastic cover	803K0-6-1082-00	2
82	hex Bolt M8*52L	50108-5-0052-N3	1
83	hex Bolt M6*65L	50106-5-0065-N0	1
84	Spring D1.0*55L	58003-6-1054-N0	1
85	hex Nut M6*1*6T	55206-2-2006-NA	1
86	Fixing bracket for magnet	706E2-3-3200-N0	1
87	Nylon nut M6*1*6T	55206-1-2006-NA	1
88	Nylon washer D6*D19*1.5T	55106-1-1915-B1	1
89	Flat washer D13*D6.5*1.0T	55106-1-1310-NA	1
90	Magnet case	58020-6-1003-M0	6
91	Magneet	58009-6-1007-01	7
\	Inner Allen spanner	58030-6-1031-D1	1
\	spanner	58030-6-1005-N2	1

Products from Darwin Fitness® are subject to strict quality control. However, if a fitness equipment purchased from us does not work perfectly, we take it very seriously and ask you to contact our customer service as indicated. We are happy to help you by phone via our service hotline.

Error Descriptions

Your fitness equipment is developed for long-term, high-quality training. However, should a problem arise, please first read the operating instructions. For further assistance, please contact your contract partner or call our service hotline. To ensure your problem is solved as quickly as possible, please describe the defect as exactly as possible.

In addition to the statutory warranty, we provide a warranty for every fitness equipment purchased from us according to the following provisions.

Your statutory rights are not affected.

Warranty

The warrantee is the first/original buyer and/or any person who received a newly purchased product as a gift from the original buyer.

Warranty period

The warranty periods, shown on our web shop, begin on delivery of the fitness equipment. The respective warranty periods for your equipment can be found on its product website.

Repair Costs

According to our choice, there will either be a repair, a replacement of individual damaged parts or a complete replacement. Spare parts, that have to be mounted while assembling the equipment, have to be replaced by the warrantee personally and are not a part of repair. After the expiration of the warranty period, the responsibility for parts costs, repair costs, installation costs and delivery costs lies with the warranty holder.

The terms of use are defined as follows:

- + Home use: solely for private use in private households up to 3 hours per day
- + Semi-professional use: up to 6 hours per day (e. g. rehabilitation centres, hotels, clubs, company gyms)
- + Professional use: more than 6 hours per day (e. g. commercial gyms)

Warranty Service

Within the warranty period, equipment which develops faults as a result of material or manufacturing defects, will be repaired or replaced at our discretion. Ownership of equipment or parts of equipment which have been replaced is transferred to us. The warranty period is not extended nor does a new warranty period begin following repair or replacement under the warranty.

Warranty Conditions

For the warranty to be valid, the following steps must be taken:

Please contact our customer service by email or phone. If the product under warranty has to be sent in for repair, the seller bears costs. After expiry of the warranty, the buyer bears the costs of transport and insurance. If the fault is covered by our warranty, you will receive a new or repaired equipment in return.

Warranty claims are invalid in case of damage resulting from:

- + misuse or improper handling
- + environmental influences (moisture, heat, electrical surge, dust, etc.)
- + failure to follow the current safety measures for the equipment
- + failure to follow the operating instructions
- + use of force (e. g. hitting, kicking, falling)
- + interventions which were not carried out by one of our authorized service centres
- + unauthorised repair attempts

Proof of Purchase and Serial Number

Please make sure that you are able to provide the appropriate receipt when claiming on your warranty. So that we can clearly identify the model of your equipment, and for the purposes of our quality control, you will need to give the serial number of your equipment, when contacting the service team. Where possible please have your serial number and your customer number ready when you call our service hotline. It will help us to deal with your request swiftly.

If you cannot find the serial number on your fitness equipment, our service team is at your disposal to offer further information.

Service outside of the Warranty Period

We are also happy to issue an individual cost estimate if there is a problem with your fitness equipment after the warranty has expired, or in cases which do not fall under the terms of the warranty, e. g. normal wear and tear. Please contact our customer service team to find a quick and cost-effective solution to your problem. In such a case you will be responsible for the delivery costs.

Communication

Many problems can be solved just by speaking to us as your specialist supplier. We know how important it is to you as a user of the fitness equipment to have problems solved quickly and simply, so you can enjoy working out with minimal interruption. For that reason, we also want to resolve your queries quickly and in a straightforward manner. Thus, please always keep your customer number and the serial number of the faulty equipment handy.

DE	DK	UK
<p>TECHNIK</p> <p> +49 4621 4210-900</p> <p> +49 4621 4210-698</p> <p> technik@fitshop.de</p> <p> Öffnungszeiten entnehmen Sie unserer Homepage.</p> <p>SERVICE</p> <p> 0800 20 20277 (kostenlos)</p> <p> 04621 4210 - 0</p> <p> info@fitshop.de</p> <p> Öffnungszeiten entnehmen Sie unserer Homepage: https://stg.fit/statit4</p>	<p>TEKNIK OG SERVICE</p> <p> 80 90 16 50</p> <p>+49 4621 4210-945</p> <p> info@fitshop.dk</p> <p> Åbningstider kan findes på hjemmesiden: https://stg.fit/statit7</p>	<p>CUSTOMER SUPPORT</p> <p> 00800 2020 2772</p> <p>+494621 4210 944</p> <p> info@fitshop.co.uk</p> <p> You can find the opening hours on our homepage: https://stg.fit/statitc</p>
	FR	BE
	<p>TECHNIQUE & SERVICE</p> <p> +33 (0) 189 530984</p> <p>+49 4621 42 10 933</p> <p> info@fitshop.fr</p> <p> Vous trouverez les heures d'ouverture sur notre site Internet: https://stg.fit/statit4</p>	<p>TECHNIQUE & SERVICE</p> <p> 02 732 46 77</p> <p>+49 4621 4210 933</p> <p> info@fitshop.be</p> <p> Vous trouverez les heures d'ouverture sur notre site Internet: https://stg.fit/statit8</p>
ES	NL	INT
<p>TECNOLOGÍA Y SERVICIOS</p> <p> 911 238 029</p> <p> info@fitshop.es</p> <p> Consulta nuestro horario de apertura en la página web: https://stg.fit/statit5</p>	<p>TECHNISCHE DIENST & SERVICE</p> <p> +31 172 619961</p> <p> service@fitshop.nl</p> <p> De openingstijden vindt u op onze homepage: https://stg.fit/statit3</p>	<p>TECHNICAL SUPPORT & SERVICE</p> <p> +49 4621 4210-944</p> <p> service-int@fitshop.de</p> <p> You can find the opening hours on our homepage: https://stg.fit/statita</p>
PL	AT	CH
<p>DZIAŁ TECHNICZNY I SERWIS</p> <p> 22 307 43 21</p> <p>+49 4621 42 10-948</p> <p> info@fitshop.pl</p> <p> Godziny otwarcia można znaleźć na stronie głównej: https://stg.fit/statit6</p>	<p>TECHNIK & SERVICE</p> <p> 0800 20 20277 (Freecall)</p> <p>+49 4621 42 10-0</p> <p> info@fitshop.at</p> <p> Öffnungszeiten entnehmen Sie unserer Homepage: https://stg.fit/statitb</p>	<p>TECHNIK & SERVICE</p> <p> 0800 202 027</p> <p>+49 4621 42 10-0</p> <p> info@fitshop.ch</p> <p> Öffnungszeiten entnehmen Sie unserer Homepage: https://stg.fit/statit9</p>

Please find a detailed overview including address and opening hours for all stores of the Fitshop Group in Germany and abroad on the following website:

www.fitshop.com/en/stores

WE LIVE FITNESS

WEBSHOP AND SOCIAL MEDIA

Fitshop is Europe's largest specialist store for home fitness equipment with currently over 70 stores and one of the world's most renowned online mail order companies for fitness equipment. Private customers order via the 25 web shops in the respective national language or have their desired equipment assembled on site. In addition, the company supplies fitness studios, hotels, sports clubs, companies and physio practices with professional equipment for endurance and strength training.

Fitshop offers a wide range of fitness equipment from renowned manufacturers, high-quality in-house developments and comprehensive services, such as a build-up service and sports scientific advice before and after the purchase. The company employs numerous sports scientists, fitness trainers and competitive athletes.

Visit us also on our social media platforms or our blog!

FIT SHOP	www.fitshop.co.uk www.fitshop.de/blog
-----------------	--

f	www.facebook.com/fitshop.co.uk
----------	--

	www.instagram.com/fitshop_uk
--	--

	www.youtube.com/@fitshop_uk
--	--

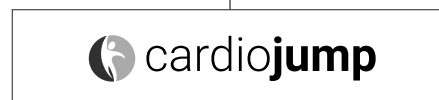

Notes

Notes

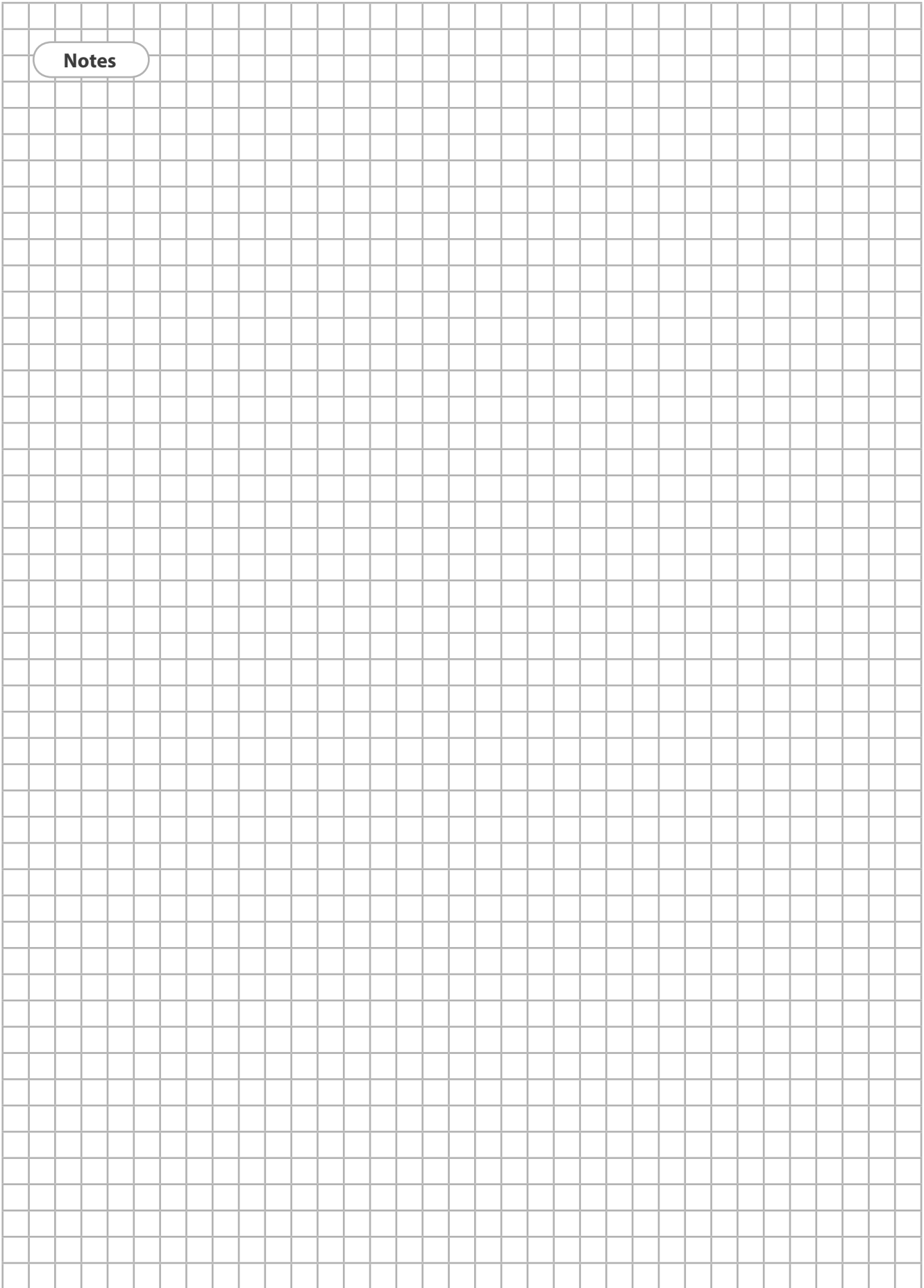



DARWIN HT40