

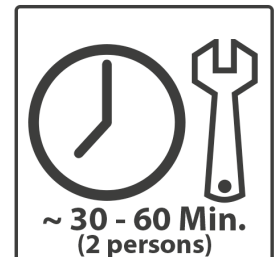

Assembly and Operating Instructions

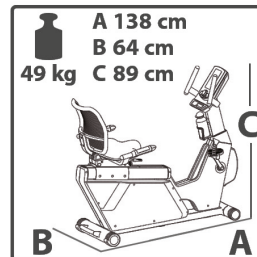

DFRB40.01.01

Art. No. DF-RB40

DARWIN **RB40**

Content

| | | |
|----------|--|-----------|
| 1 | GENERAL INFORMATION | 7 |
| 1.1 | Technical Data | 7 |
| 1.2 | Personal Safety | 8 |
| 1.4 | Electrical Safety | 9 |
| 1.3 | Set-Up Place | 9 |
| 2 | ASSEMBLY | 10 |
| 2.1 | General Instructions | 10 |
| 2.2 | Scope of Delivery | 11 |
| 2.3 | Assembly | 12 |
| 3 | OPERATING INSTRUCTIONS | 18 |
| 3.1 | Console Display | 18 |
| 3.2 | Button Functions | 19 |
| 3.3 | Turning On and Setting the Equipment | 19 |
| 3.4 | Programmes | 20 |
| 3.4.1 | MANUAL - Manual Programme | 21 |
| 3.4.2 | PROGRAM - Pre-Set Programmes | 21 |
| 3.4.3 | USER PROGRAM - User Defined Programme | 21 |
| 3.4.4 | H.R.C. - Heart Rate Controlled Programmes | 22 |
| 3.4.5 | WATT - Watt Controlled Programme | 22 |
| 3.4.6 | RECOVERY - Recovery Heart Rate Status | 23 |
| 3.4.7 | BODY FAT - Body Fat Test | 23 |
| 4 | STORAGE AND TRANSPORT | 24 |
| 4.1 | General Instructions | 24 |
| 4.2 | Transportation Wheels | 24 |
| 5 | TROUBLESHOOTING, CARE AND MAINTENANCE | 25 |
| 5.1 | General Instructions | 25 |
| 5.2 | Faults and Fault Diagnosis | 25 |
| 5.3 | Maintenance and Inspection Calendar | 26 |
| 6 | DISPOSAL | 26 |
| 7 | RECOMMENDED ACCESSORIES | 27 |

| | | |
|-----------|------------------------------|-----------|
| 8 | ORDERING SPARE PARTS | 28 |
| 8.1 | Serial Number and Model Name | 28 |
| 8.2 | Parts List | 29 |
| 8.3 | Exploded Drawing | 32 |
| 9 | WARRANTY | 33 |
| 10 | CONTACT | 35 |

Dear customer,

Thank you for choosing a high-quality equipment of the brand Darwin®. Darwin® offers sports and fitness equipment for the sophisticated home sport and the equipment of fitness studios and business customers. With Darwin® fitness equipment, the focus is on what sport is all about: maximum performance! Therefore, the equipment is developed in close consultation with athletes and sports scientists. Because athletes know best what makes perfect fitness equipment.

Further information can be found at www.sport-tiedje.com.

Intended Use

The equipment may only be used for its intended purpose.

The equipment is only suitable for home use. The equipment is not suitable for semi-professional (e.g. hospitals, associations, hotels, schools, etc.) and commercial or professional use (e.g. fitness studios).

Legal Notice

Sport-Tiedje GmbH
Europe's No. 1 for home fitness

International Headquarters
Flensburger Straße 55
24837 Schleswig
Germany

Management:
Christian Grau
Sebastian Campmann
Dr. Bernhard Schenkel
No. HRB 1000 SL
Local Court Flensburg
European VAT Number: DE813211547

Disclaimer



©2015 Darwin® is a registered brand of the company SportTiedje GmbH. All rights reserved. Any use of this trademark without the explicit written permission of Sport-Tiedje is prohibited.

Product and manual are subject to change. Technical data can be changed without advance notice.

ABOUT THIS MANUAL

Please carefully read the entire manual before installation and first use. The manual will help you to quickly set up the system and explains how to safely use it. Make sure that all persons exercising with the equipment (especially children and persons with physical, sensory, mental or motor disabilities) are informed about this manual and its contents in advance. In case of doubt, responsible persons must supervise the use of the equipment.



This equipment has been manufactured according to the latest safety knowledge. As far as possible, potential safety hazards which could cause injury have been eliminated. Make sure to carefully follow the instructions and that all parts are securely in place. If required, read through the instructions again to correct any mistakes.

Please pay close attention to the safety and maintenance instructions given here. The contract partner cannot be held liable for damage to health, accidents or damage to the equipment when it is not used in accordance with these instructions.

The following safety instructions may appear in this manual:

► **ATTENTION**

This notice indicates potentially hazardous situations which, if not avoided, may result in property damage.

⚠ **CAUTION**

This notice indicates potentially hazardous situations which, if not avoided, may result in slight or minor injuries!

⚠ **WARNING**

This notice indicates potentially hazardous situations which, if not avoided, may result in death or serious injuries!

⚠ **DANGER**

This notice indicates potentially hazardous situations which, if not avoided, will result in death or serious injuries!

ⓘ **NOTICE**

This notice indicates further useful information.

Retain these instructions in a safe place for future reference, maintenance or when ordering replacement parts.

1.1 Technical Data

LED display

- + speed in km/h
- + cadence (rotations per minute)
- + training time in min
- + training distance in km
- + calorie consumption in kcal
- + heart rate (when using the hand pulse sensors or a chest strap)
- + Watt / resistance level

Resistance system: electronic magnetic brake system

Resistance levels: 16

Watt: 10 - 350 Watt (adjustable in 5-Watt increments)

Balance mass: 9.5 kg

| | |
|--------------------------------------|----|
| User memory: | 4 |
| Total number of training programmes: | 19 |
| Manual programmes: | 1 |
| Pre-set programmes: | 12 |
| Watt-controlled program: | 1 |
| Heart rate controlled programmes: | 4 |
| User defined programmes: | 1 |

Weight and dimensions:

Product weight (gross, incl. packaging): 54 kg

Product weight (net, without packaging): 49 kg

Packaging dimensions (L x W x H): 163 cm x 24.5 cm x 65 cm

Set-up dimensions (L x W x H): 138 cm x 64 cm x 89 cm

Maximum user weight: 130 kg

1.2 Personal Safety

DANGER

- + Before you start using the equipment, you should consult your physician that this type of exercise is suitable for you from a health perspective. Particularly affected are persons who: have a hereditary disposition to high blood pressure or heart disease, are over the age of 45, smoke, have high cholesterol values, are overweight and/or have not exercised regularly in the past year. If you are under medical treatment that affects your heart rate, medical advice is absolutely essential.
- + Note that excessive training can seriously endanger your health. Please also note that heart rate monitoring systems can be inaccurate. If you notice any signs of weakness, nausea, dizziness, pain, shortness of breath, or other abnormal symptoms, stop exercising immediately and seek advice from your doctor if necessary.

WARNING

- + This equipment may not be used by children under the age of 14.
- + Children should not be allowed unsupervised access to the equipment.
- + Persons with disabilities must have a medical license and must be under strict observation when using the equipment.
- + The equipment is strictly for use by one person at a time.
- + If your equipment provides a safety key, the clip of the safety key must be attached to your clothing before starting your training. In the event of a fall, the EMERGENCY STOP of the equipment can be initiated.
- + Keep your hands, feet and other body parts, hair, clothing, jewellery and other objects well clear of moving parts.
- + During use, wear suitable sports clothing rather than loose or baggy clothing. When wearing sports shoes, make sure they have suitable soles, preferably made of rubber or other non-slip materials. Shoes with heels, leather soles, studs or spikes are unsuitable. Never exercise barefoot.

CAUTION

- + If your equipment needs to be connected to the power supply with a mains cable, make sure that the cable is not a potential tripping hazard.
- + Make sure that nobody is within the range of motion of the equipment during training so as not to endanger you or other persons.

ATTENTION

- + Do not insert any objects of any kind into the openings of the device.

1.4 Electrical Safety

DANGER

- + In order to reduce the risk of an electric shock, always unplug the equipment from the mains socket immediately after your workout, before assembly or dismantling, and before maintenance or cleaning. Do not pull on the cable.

WARNING

- + Do not leave the equipment unattended while the mains cable is plugged into the mains socket. During your absence, the mains cable must be removed from the mains socket to prevent improper use by third parties or children.
- + If the mains cable or plug is damaged or defective, contact your contract partner. Until repair, the equipment must not be used.

ATTENTION

- + The equipment requires a mains connection of 220-230 V with 50 Hz mains voltage.
- + The equipment may only be connected directly to an earthed socket using the supplied mains cable. Extension cables must conform to VDE guidelines. Always completely unwind the mains cable.
- + The socket must be protected by a fuse with a minimum fuse rating of "16 A, slow blow".
- + Do not make any changes to the mains cable or the mains plug.
- + Keep the mains cable away from water, heat, oil and sharp edges. Do not route the mains cable underneath the equipment or under a carpet or rug, and do not place any objects on top of it.

1.3 Set-Up Place

WARNING

- + Do not place the equipment in main corridors or escape routes.

CAUTION

- + The training room should be well ventilated during training and not be exposed to any draughts.
- + Choose the place in which to set up the equipment such that there is enough free space/clearance to the front, the rear and to the sides of the equipment.
- + The set-up and mounting surface of the equipment should be flat, loadable and solid.

ATTENTION

- + The device may only be used in one building, in sufficiently tempered and dry rooms (ambient temperatures between 10°C and 35°C). The equipment should not be used outdoors or in rooms with high humidity (over 70%) like swimming pools.
- + A floor protective mat/equipment underlay can help to protect high-quality floor coverings (parquet, laminate, cork, carpets) from dents and sweat and can help to level out slight unevenness.

2.1 General Instructions



DANGER

- + Do not leave any tools, packaging materials such as foils or small parts lying around, as otherwise there is a danger of suffocation for children. Keep children away from the equipment during assembly.



WARNING

- + Pay attention to the instructions attached to the equipment in order to reduce the risk of injuries.



CAUTION

- + Do not open the packaging when it is lying on its side.
- + Ensure to have sufficient room for movement in each direction during assembly.
- + The assembly of the equipment must be carried out by at least two adults. If in doubt, seek the help of another technically skilled person.



ATTENTION

- + To prevent damage to the equipment and the floor, assemble the equipment on a mat or packaging board.



NOTICE

- + In order to make the assembly as simple as possible, some screws and nuts to be used can already be pre-assembled.
- + Ideally, assemble the equipment at its later set-up place.

2.2 Scope of Delivery

The scope of delivery consist of the following parts. At the beginning, check whether all parts and tools belonging to the device are included in the scope of delivery and whether damage has occurred. In the event of complaints, the contractual partner must be contacted directly.

⚠ CAUTION

If parts of the scope of delivery are missing or damaged, the assembly must not be carried out.

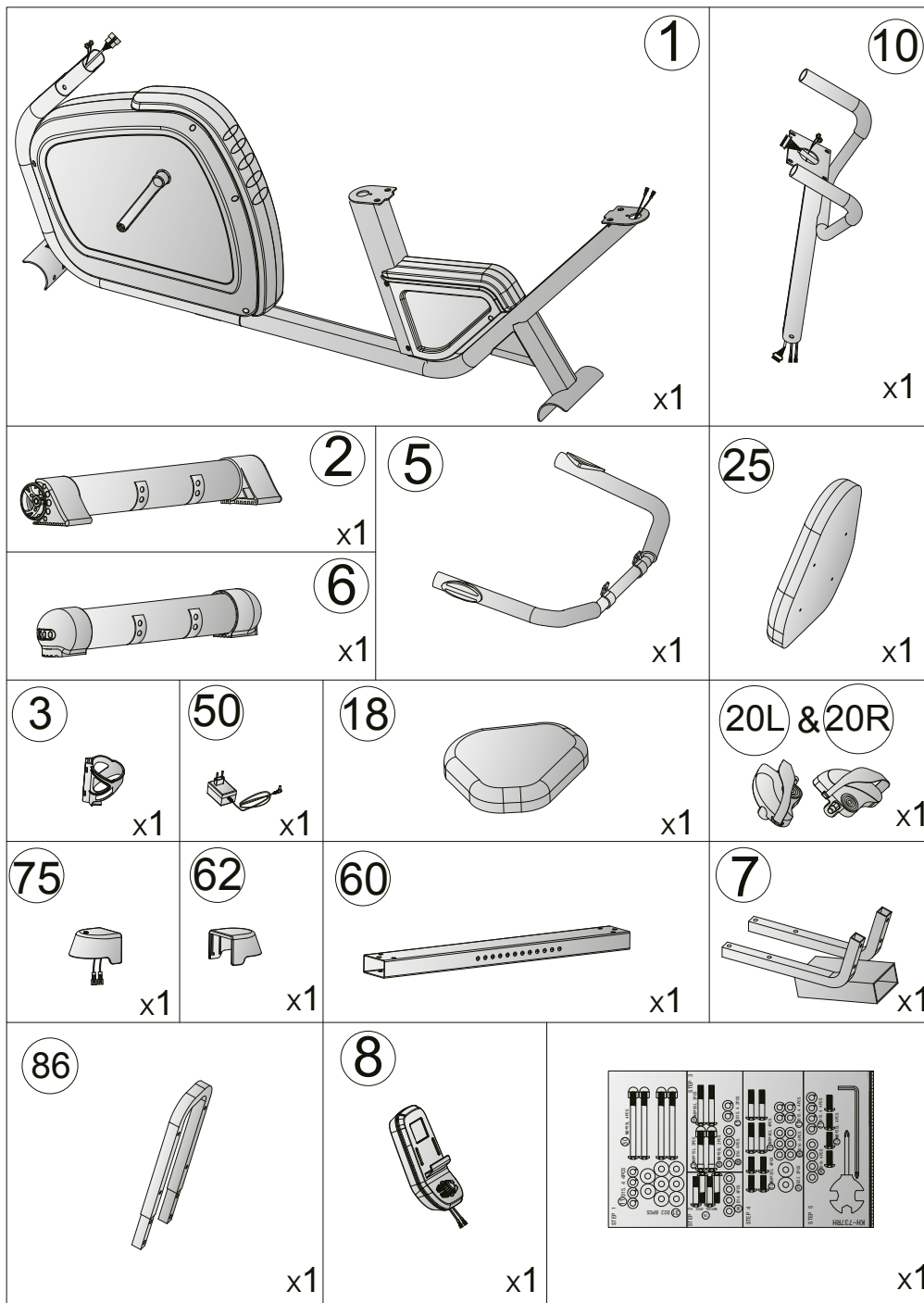

2.3 Assembly

Before assembly, take a close look at the individual assembly steps shown and carry out the assembly in the order given.

NOTICE

First loosely screw all parts together and check that they fit properly. Then tighten the screws using the tool only when you are instructed to do so.

Step 1: Stand construction

1. Mount the front stabilizer (2) to the main frame (1) using four curved washers (31), two spring washers (11), two cup nuts (12) and two bolts (30).
2. Mount the rear stabilizer (6) to the main frame (1) using four curved washers (31), two spring washers (11), two cup nuts (12) and two bolts (30).
3. Level out any unevenness in the floor by turning the wheels on the rear foot caps.
4. Tighten the bolts with the tool.

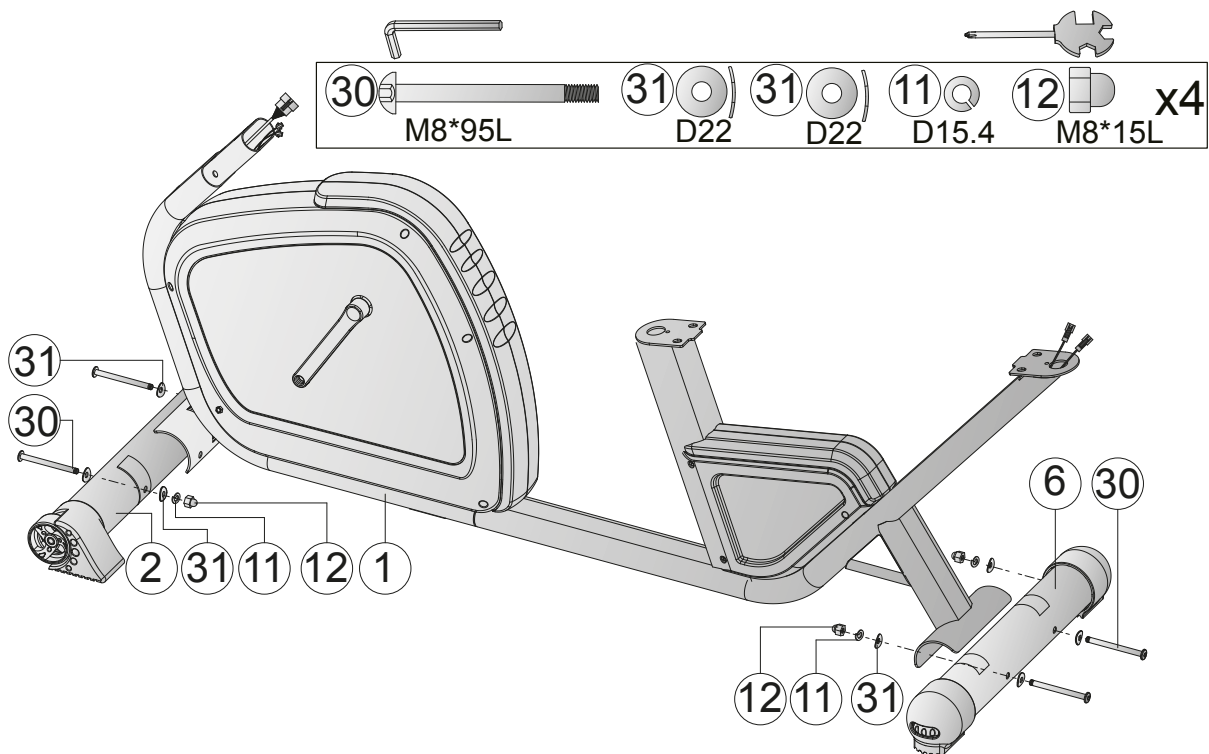

Step 2: Assembling the seat and the slide rail

1. Mount the seat (18) to the seat post (7) using four flat washers (66) and four bolts (15).
2. Tighten the bolts with the tool.
3. Mount the seat post (7) to the sliding beam (60) by pulling out the rotary knob on the seat post and allowing it to engage in one of the holes in the sliding beam (60).

NOTICE:

You can adjust the seat horizontally along the rail according to your personal preferences.

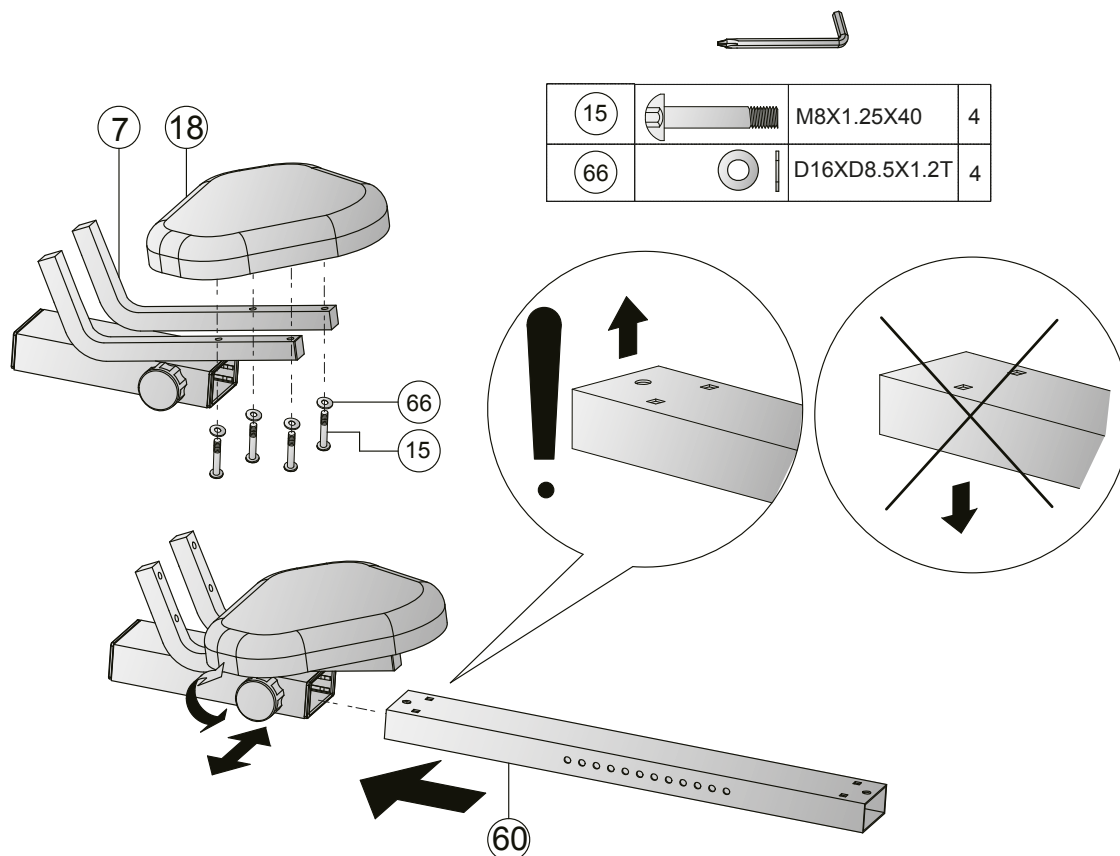

Step 3: Mounting the seat and covers

1. Mount the sliding beam (60) to the main frame (1) using two flat washers (66) and two bolts (55) (Fig. A) and two square neck bolts (56), two flat washers (66), two spring washers (11), two cup nuts (12) (Fig. B).
2. Tighten the screws with the tool.
3. Fit the front rear cover (62) to the sliding beam (60) (Fig. C).
4. Connect the two cables (47) to their corresponding counterparts (48) of the cover (75) (Fig. D & E).

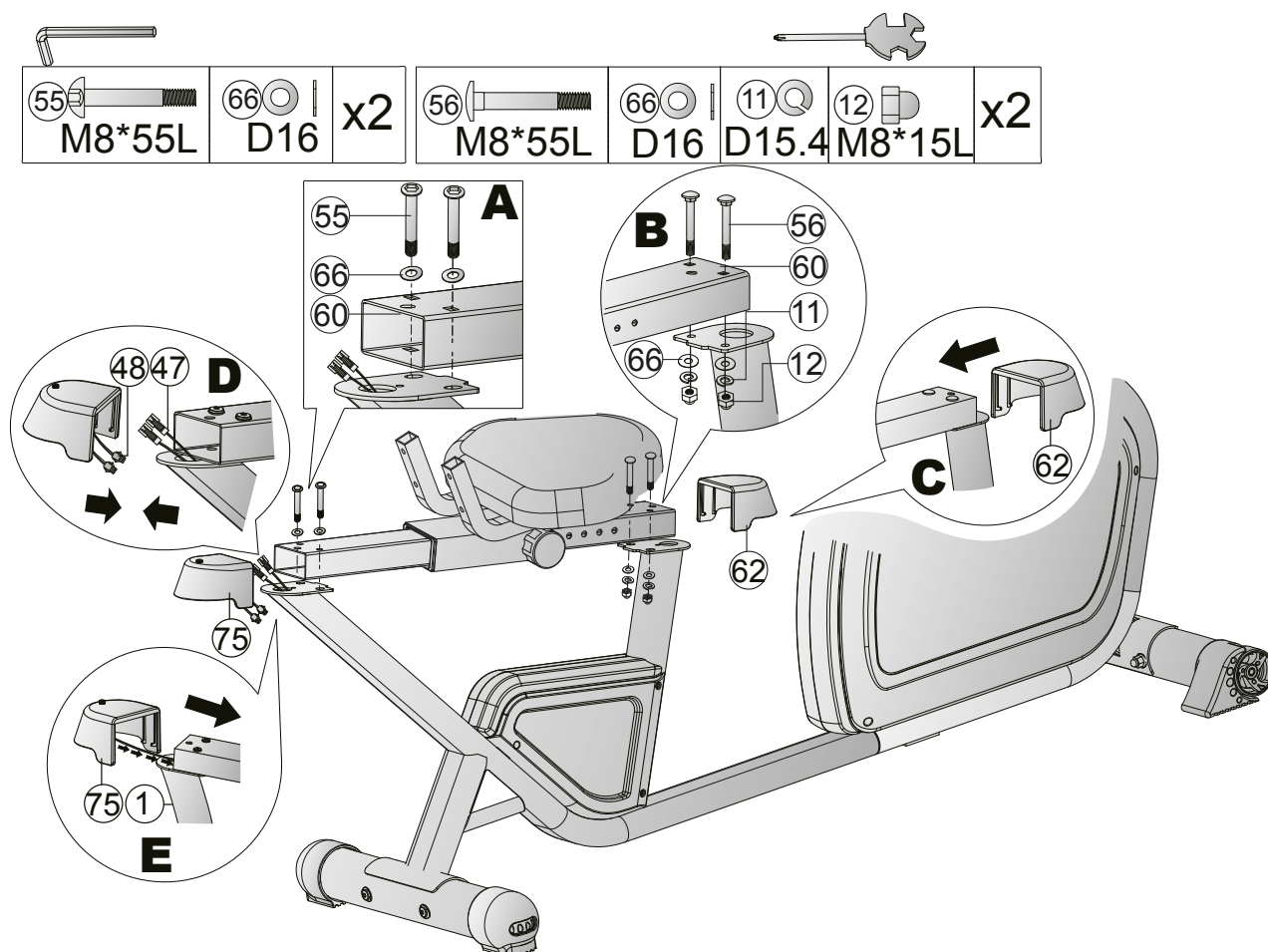

Step 4: Mounting the console mast and the backrest

1. Connect the cable (41) of the handlebar post tube (10) to the cable (88) of the main frame (1).
2. Connect the cable (46) of the handlebar post tube (10) and the cable (47) of the main frame (1).

► ATTENTION

Pay attention to not pinch the cables during the next step.

3. Put the handlebar post tube (10) on the main frame (1) and fix it with four spring washers (11), two flat washers (66), four bolts (13) and two curved washers (31).
4. Mount the backrest (25) to the backrest supporting tube (86) using four flat washers (66) and four bolts (15) and slide the backrest supporting tube (86) into the seat post (7).
5. Tighten the bolts using the tool.

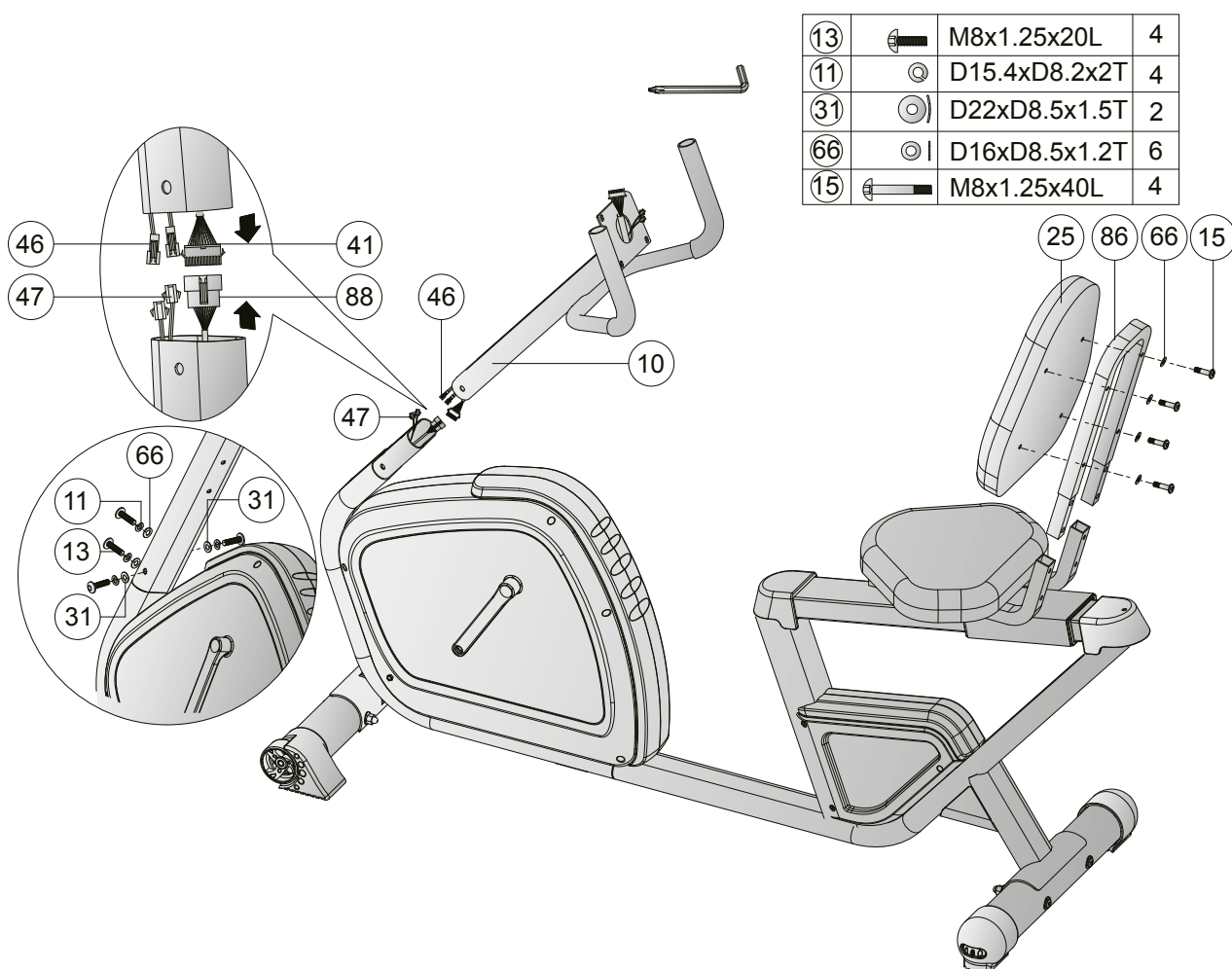

Step 5: Mounting the pedals and hand pulse sensors

1. Mount the left and right pedal (20L & 20R) on the crank arms (39L & 39R).
2. Mount the bottle holder (3) to the handlebar post tube (10) with two bolts (4).
3. Mount the handlebar set (5) on the backrest supporting tube (86) with four flat washers (66) and four spring washers (11) and four bolts (13).
4. Connect the cable (49) of the handlebar set (5) to the port (48) on the cover (75).
5. Tighten the bolts with the tool.

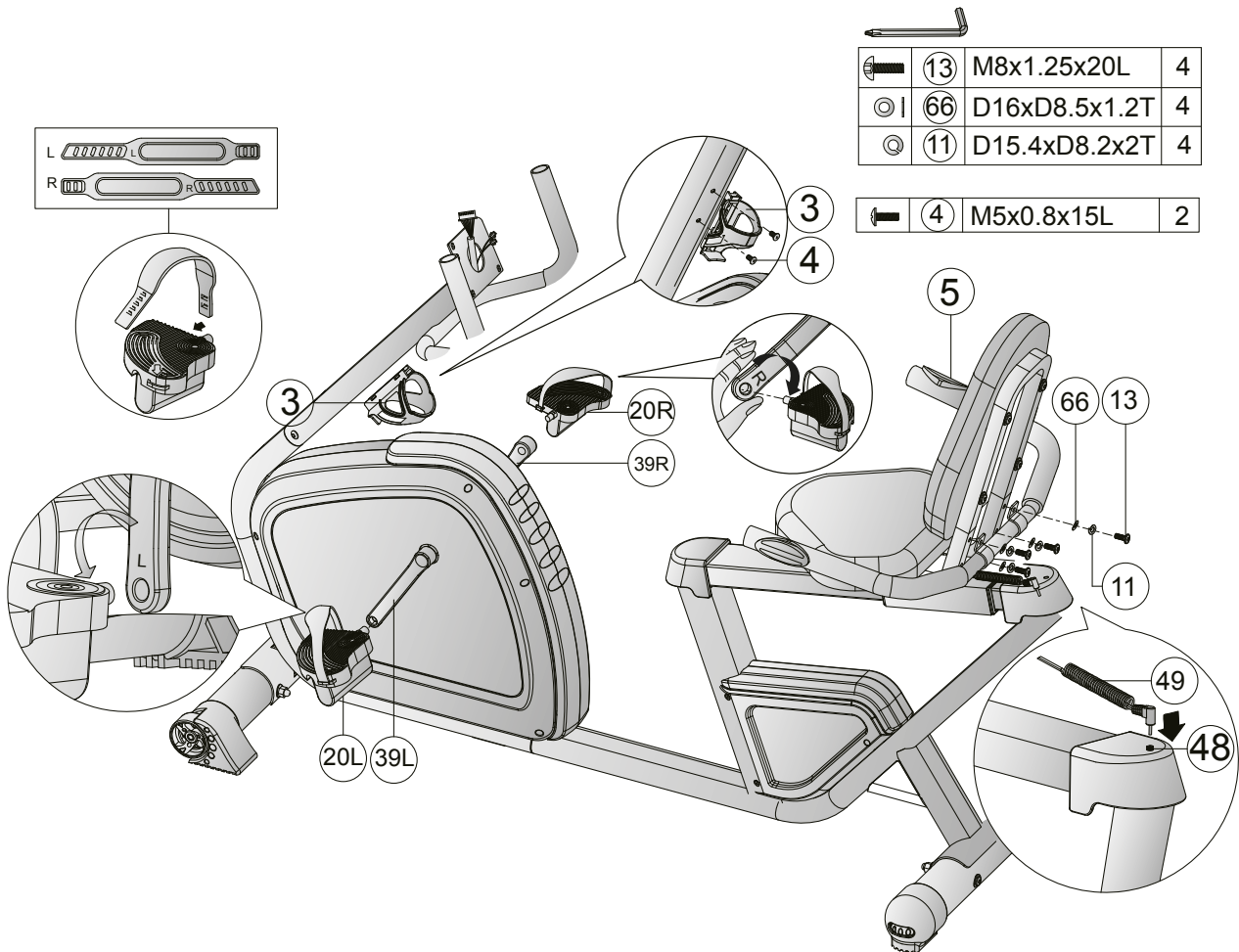

Step 6: Mount the console and connect the unit to the power supply

1. Connect the cables (41 & 46) of the handlebar post tube (10) to the cables of the console (8).
2. Place the console (8) on the handlebar post tube (10) and mount it with four bolts (87).
3. Tighten the bolts with the tool.

► ATTENTION

The device must not be connected to a multiple socket, otherwise it cannot be guaranteed that the device will be supplied with sufficient power. Technical errors can result.

4. Plug the power plug into a wall outlet that complies with the electrical safety instructions in the chapter on electrical safety.

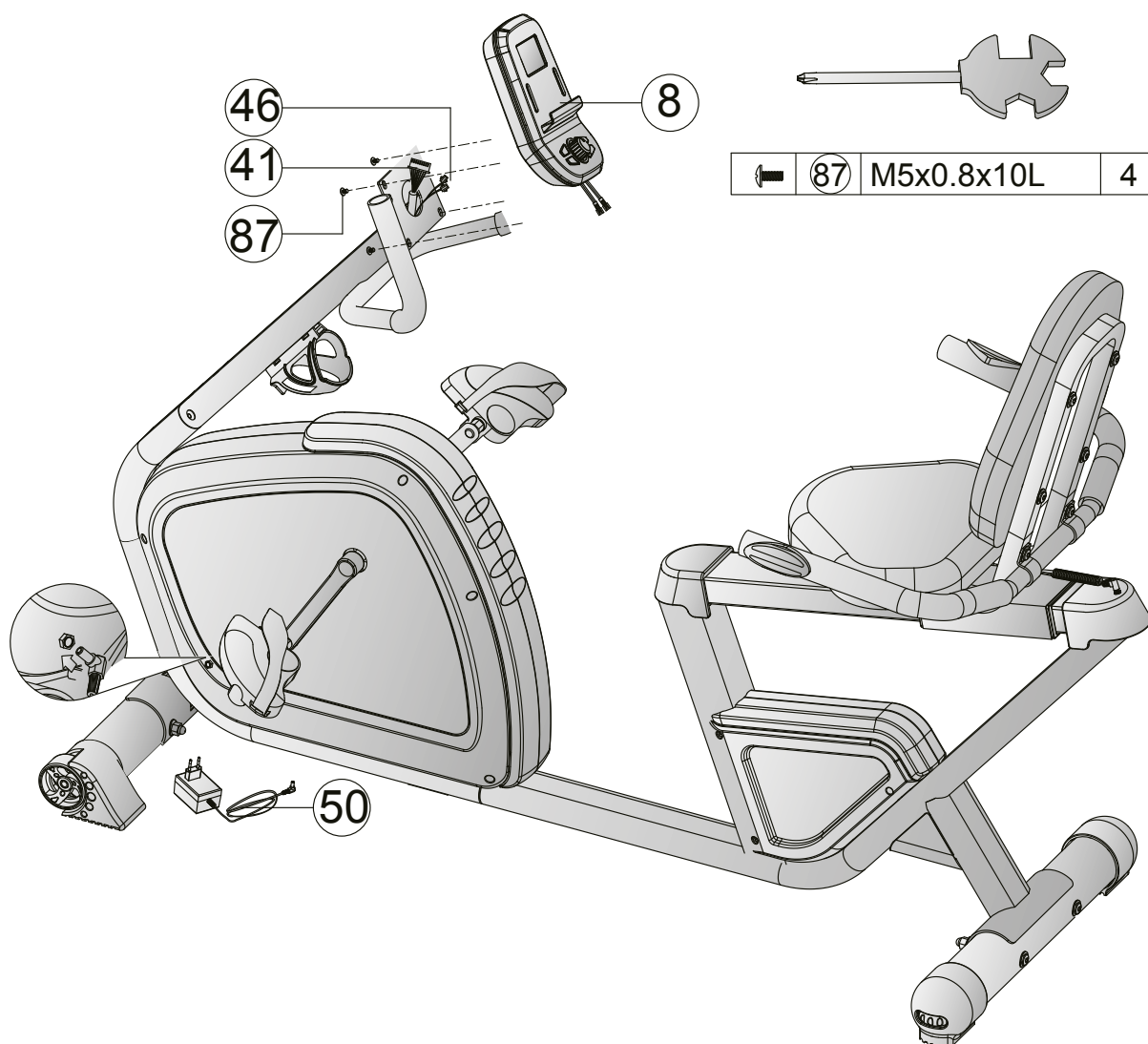

3 OPERATING INSTRUCTIONS

① NOTICE

Familiarise yourself with all the functions and setting options of the device before starting training. Have the proper use of this product explained to you by a specialist.

3.1 Console Display



| | |
|---|---------------------------------------|
| Time | 0:00–99:00 minutes |
| Speed | 0.0–99.9 km/h |
| RPM (cadence; rotations per minute) | 0–999 RPM |
| Distance | 0.0–99.9 km |
| Calories | 0–9999 Cal |
| Pulse (heart rate; beats per minute) | 60–230 BPM |
| Watt/load (output/resistance) | 0–999 Watt; Watt control: 10–350 Watt |
| Level (resistance) | 1–16 |

3.2 Button Functions

| | |
|-------------------|--|
| START STOP | + Start and stop the training |
| RECOVERY | + Check state of recovery of heart rate |
| PLUS | + Select training mode or increase functional value |
| MINUS | + Select training mode or lower functional value |
| RESET | + Press the button in the stop mode to return to the main menu |
| MODE | + Confirm setting |

3.3 Turning On and Setting the Equipment

1. Connect the training equipment to the power outlet.

The console display will show all segments with a long beep.

2. Choose one of the user profiles (U1–U4) with the encoder and confirm with MODE.
3. Set the values for sex, age, height and weight with the encoder and confirm all entries with MODE.

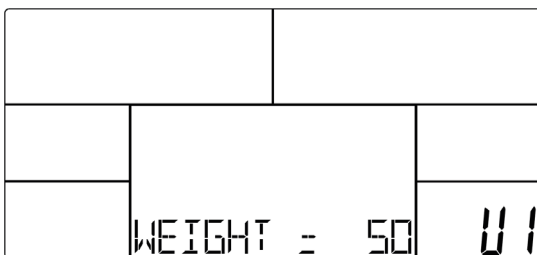
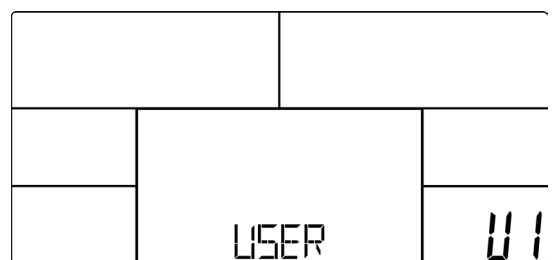
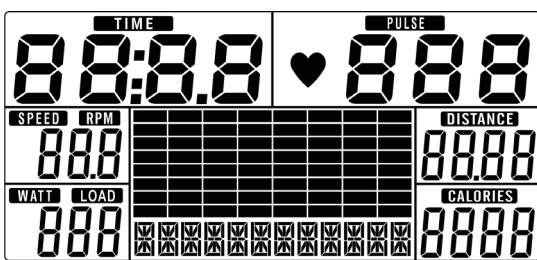

3.4 Programmes

The console offers a variety of programmes. These include the following:

- + Manual (manual training): 1
- + Program (pre-set training programmes): 12
- + User Program (user-defined training programme): 4
- + H.R.C. (heart rate controlled training programmes): 4
- + Watt (Watt-controlled training programme): 1
- + Recovery (fitness test)
- + Body Fat (Body fat test)

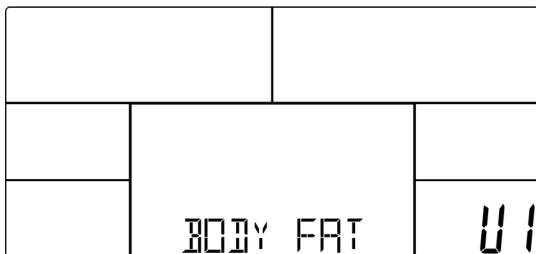
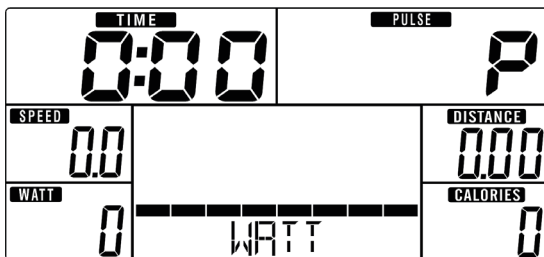
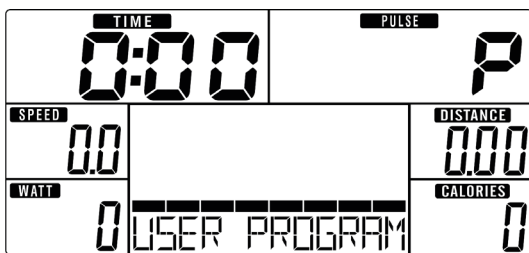
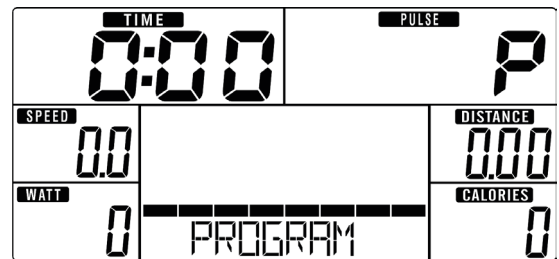
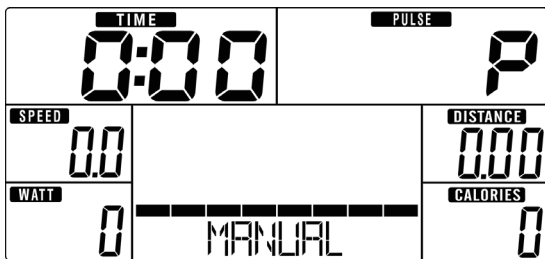

3.4.1 MANUAL - Manual Programme

1. Select the target programmes (MANUAL) with the encoder and press MODE for confirmation.
2. Enter load level with the encoder and confirm with MODE.
3. Enter the time, distance, calories and/or pulse value/s with the encoder and confirm with MODE.
4. Press START to begin the training.

① NOTICE

The load can be adjusted with the encoder during your training.

5. Press STOP to stop the training.
6. Press RESET in order to return to the main menu.

3.4.2 PROGRAM - Pre-Set Programmes

1. Select the pre-set programmes (PROGRAM) with the encoder and confirm with MODE.
2. Use the encoder to select one of the 12 programmes.
3. Adjust the load level with the encoder and confirm with MODE.
4. Enter the time value with the encoder and confirm with MODE.
5. Press START to begin the training.

① NOTICE

The load can be adjusted with the encoder during your training.

6. Press STOP to stop the training.
7. Press RESET to return to the main menu.

3.4.3 USER PROGRAM - User Defined Programme

① NOTICE

For each user profile (U1-U4) you can set one individual user defined programme.

1. Select the user defined programme (USER PROGRAM) with the encoder and confirm with MODE.
2. Enter one load level for all the segments with the encoder and press MODE to confirm each setting.
3. After all settings, press MODE for three seconds.
4. Enter the time value with the encoder and confirm with MODE.
5. Press START to begin the training.

① NOTICE

The load can be adjusted with the encoder during your training.

6. Press STOP to stop the training.
7. Press RESET to return to the main menu.

3.4.4 H.R.C. - Heart Rate Controlled Programmes

 **WARNING**

Your training equipment is not a medical device. The heart rate measurement of this equipment may be inaccurate. Various factors can affect the accuracy of the heart rate measurement. The heart rate measurement serves only as a training aid.

1. Select the heart rate controlled programmes (HRC) with the encoder and confirm with MODE.
2. Select one of the pre-set heart rates (55% / 75% / 90%) or target heart rate (TAG) with the encoder and confirm with MODE.

 **NOTICE**

If you select TAG, you can enter your desired target heart rate. To do so, use the encoder and confirm with MODE.

3. Enter the TIME value with the encoder and confirm with MODE.
4. Press START to begin the training.

The load level adjusts to your current heart rate.

5. Press STOP to stop the training.
6. Press RESET to return to the main menu.

3.4.5 WATT - Watt Controlled Programme

1. Select the watt controlled programme (WATT) with the encoder and confirm with MODE.
2. Enter the watt value with the encoder and confirm with MODE.
3. Enter the time value with the encoder and confirm with MODE.

 **NOTICE**

The watt value can be adjusted with the encoder during your training.

4. Press START to begin the training. Watt can be adjusted through the encoder.
5. Press STOP to stop the training. Press RESET to return to the main menu.

3.4.6 RECOVERY - Recovery Heart Rate Status

1. After training, press RECOVERY to calculate your recovery heart rate status.
2. Hold the hand pulse sensors.

The console calculates your recovery heart rate status within 60 seconds.

The result is displayed as a note between F1 and F6, where F1 is the best and F6 the worst.

3. Press RECOVERY again to return to the main menu.

3.4.7 BODY FAT - Body Fat Test

1. Press BODY FAT to start the body fat test.
2. Hold the hand pulse sensors.

The console calculates your body fat percentage and your BMI within 8 seconds.

The results will be displayed for about 30 seconds.

4.1 General Instructions

▶ ATTENTION

- + Make sure that the equipment is protected from moisture, dust and dirt in the selected storage location. The storage location should be dry and well ventilated and have a constant ambient temperature between 5°C and 45°C.

⚠ WARNING

- + The storage location should be chosen so that improper use by third parties or children can be prevented.
- + If your equipment does not have transportation wheels, the equipment must be disassembled before transportation.

4.2 Transportation Wheels

▶ ATTENTION

If you want to transport your equipment over particularly sensitive and soft floor coverings, such as parquet, planks or laminate, lay out the transport route with cardboard or similar to avoid possible floor damage.

1. Stand behind the equipment and lift it until the weight is transferred to the transportation wheels. After that, you easily can move the equipment to a new position. For long transport distances the equipment should be disassembled and safely packed.
2. Select the new location by following the instructions in the section 1.3 of this manual.

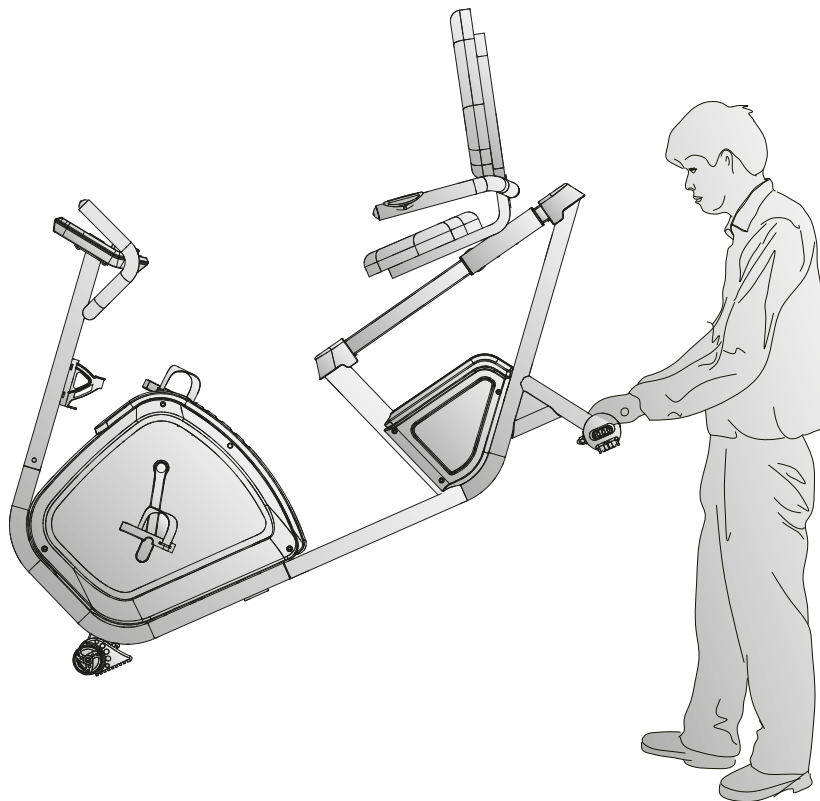

5.1 General Instructions



WARNING

+ Do not make any improper changes to the equipment.



CAUTION

+ Damaged or worn components may affect your safety and the life of the equipment. Therefore, immediately replace damaged or worn components. In such a case, contact the contract partner. The equipment must not be used until it has been repaired. If necessary, use only original spare parts.

► ATTENTION

+ In addition to the instructions and recommendations for maintenance and care given here, additional service and/or repair work may be necessary; this must only be carried out by authorised service technicians.

5.2 Faults and Fault Diagnosis

The equipment undergoes regular quality controls during production. Nevertheless, faults or malfunctions may occur. Frequently, individual parts are responsible for these disturbances, an exchange is usually sufficient. Please refer to the following overview for the most common errors and how to correct them. If the equipment still does not function properly, contact your contract partner.

| Fault | Cause | Solution |
|-------------------------------|---|--|
| Crackling noise in pedal area | Loose pedals | Tighten the pedals |
| Equipment wobbles | Equipment is not level | Adjust the supporting feet |
| Handlebar/saddle wobbles | Screws are loose | Tighten screws |
| Display does not turn on | Battery is low or the cable connection is loose | Change batteries or check cable connections |
| No pulse display | <ul style="list-style-type: none"> + Sources of interference in the room + Unsuitable chest strap + Position of the chest strap incorrect + Batteries empty + Check if heart rate can be detected via the hand pulse sensors | <ul style="list-style-type: none"> + Remove sources of interference (e. g. mobile phone, speakers, WLAN, mover- and cleaning robot, etc.) + Use suitable chest strap (see recommended accessories) + Reposition chest strap and/or moisten electrodes + Change batteries |

5.3 Maintenance and Inspection Calendar

To avoid damage from body sweat, the equipment must be cleaned with a damp towel (no solvents!) after each training session.

The following routine tasks must be performed at the specified intervals:

| Part | Weekly | Monthly | Quarterly | Half-yearly | Yearly |
|--------------------------------|--------|---------|-----------|-------------|--------|
| Display console | C | I | | | |
| Plastic covers | C | I | | | |
| Screws and cable connections | | I | | | |
| Legend: C = clean; I = inspect | | | | | |

6 DISPOSAL

At the end of its operational life, this equipment cannot be disposed of in normal household waste. Instead, it must be disposed of via an electricals recycling centre. Further information can be obtained from your local authority’s recycling service.



The materials can be recycled as per their symbols. Through the reuse, recycling of materials or other forms of recovery of old equipment, you make an important contribution to the protection of the environment.

To make your training experience even more efficient and pleasant, we recommend that you add suiting accessories to your fitness equipment. This could be a floor mat, for example, which makes your fitness equipment stand more securely and also protects the floor from falling sweat, but it could also be additional handrails on some treadmills or silicone spray to keep moving parts in good shape.

If you have purchased a fitness machine with pulse training and want to train your heart rate, we strongly recommend that you use a compatible chest strap, as this ensures optimum transmission of the heart rate. You may want to buy additional grips or weights for multi gyms.

Our range of accessories offers the highest quality and makes training even better. If you would like to find out more about compatible accessories, please go to the detail page of the product in our webshop (the easiest way is to enter the article number in the search field above) and go to the recommended accessories on this page. Of course, you can also contact our customer service: by telephone, e-mail, in one of our branches or via our social media channels. We will be happy to advise you!



floor mat



chest strap



chest strap contact gel



towels



silicone spray

8.1 Serial Number and Model Name

In order to provide you with the best possible service, please have the model name, article number, serial number, exploded drawing and parts list ready. The corresponding contact options can be found in chapter 10 of this operating manual.

NOTICE

The serial number of your equipment is unique. It's located on a white sticker. The exact position of this sticker is shown in the following illustration.

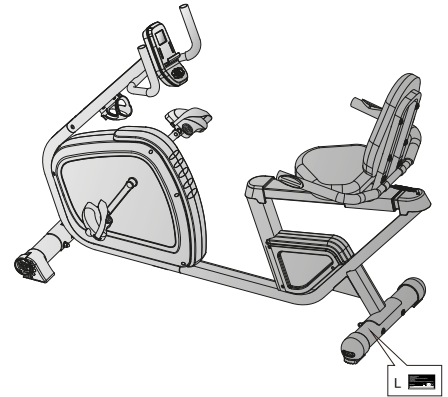

Enter the serial number in the appropriate field.

Serial number:

Brand / Category:

Darwin / Recumbent Bike

Model Name:

RB40

Article Number:

DF-RB40

8.2 Parts List

| No. | Name | Specification | Qty. |
|-------|--------------------------|-------------------|------|
| 1 | Main frame | | 1 |
| 2 | Front stabilizer | D76x1.5Tx480L | 1 |
| 3 | Bottle holder | 120*87*3T | 1 |
| 4 | Bolt | M5*0.8*15L | 2 |
| 5 | Handlebar set | | 1 |
| 6 | Rear stabilizer | D76x1.5Tx480L | 1 |
| 7 | Seat post | | 1 |
| 8 | Computer | SM-1730-31 | 1 |
| 9L | Left rolling foot cap | D76*120L | 1 |
| 9R | Right rolling foot cap | D76*120L | 1 |
| 10 | Handlebar post tube | | 1 |
| 11 | Spring washer | D15.4xD8.2x2T | 14 |
| 12 | Cup nut | M8x1.25x15L | 6 |
| 13 | Bolt | M8x1.25x20L | 8 |
| 14 | Flywheel set | | 1 |
| 15 | Bolt | M8*1.25*40 | 8 |
| 16 | Screw cover | D26*11L | 2 |
| 17 | Plastic washer | D10*D24*0.4T | 2 |
| 18 | Seat | 348*270*52 | 1 |
| 19 | Bolt | M10*35L | 1 |
| 20L&R | Pedal set | JD-22A 9/16"tooth | 1 |
| 21 | Flat washer | D30*D8.5*2.0T | 1 |
| 22 | Screw | ST4*1.4L*20L | 2 |
| 23 | Anti-slip nut | 3/8"-26UNFx6.5T | 2 |
| 24 | Fixed bracket for magnet | | 1 |
| 25 | Backrest | 410*340*57 | 1 |
| 26 | Tension cable | D1.5*130L, | 1 |
| 27 | Spring | D1.0*55L | 1 |
| 28 | Bolt | M6*65L | 1 |
| 29 | Nut | M6*1*6T | 1 |
| 30 | Bolt | M8*1.25*95L | 4 |
| 31 | Curved washer | D22xD8.5x1.5T | 10 |

| | | | |
|-----|---------------------------|--------------------|---|
| 32 | Power cord | 400L | 1 |
| 33 | Sensor cable | 400L | 1 |
| 34 | Waved washer | D22*D17*0.3T | 2 |
| 35 | C-ring | S-17(1T) | 1 |
| 36 | Belt | 410 J5 (1041 J5) | 1 |
| 37 | Belt wheel | D260*19 | 1 |
| 38 | Round magnet | M02 | 1 |
| 39L | Left crank | 6 1/2"x9/16"-20UNF | 1 |
| 39R | Right crank | 6 1/2"x9/16"-20UNF | 1 |
| 40 | Ball knob | D50xM16x32xD8 | 1 |
| 41 | Upper computer cable | 700L | 1 |
| 42 | Motor | | 1 |
| 43 | Adjustable foot cap | D76*86 | 2 |
| 44 | Buffer | D20*10L*M8*1.25 | 1 |
| 45L | Left chain cover | 594*80.3*495 | 1 |
| 45R | Right chain cover | 594*76*495 | 1 |
| 46 | Upper handle pulse cable | 600L | 2 |
| 47 | Middle handle pulse cable | 2400L | 2 |
| 48 | Lower handle pulse cable | 100L | 1 |
| 49 | Handle pulse cable | 800L | 1 |
| 50 | Adaptor | OUTPUT:9VA,500MA | 1 |
| 51 | Crank welding set | | 1 |
| 52 | Spacer bushing | D13.5*D10*9 | 1 |
| 53 | Fixed plate for idle | 156*62.2*5T | 1 |
| 54 | Idle | D42*D38*24 | 1 |
| 55 | Bolt | M8*1.25*55L | 2 |
| 56 | Square neck bolt | M8x1.25x55L | 2 |
| 57 | Plastic sleeve | D3*30L | 2 |
| 58 | Cap | D25.4x31L | 4 |
| 59L | Rear chain cover(Left) | 321*44*242 | 1 |
| 59R | Rear chain cover(Right) | 321*39.6*242 | 1 |
| 60 | Sliding beam | | 1 |
| 61 | Bolt | M8x1.25x25 | 2 |

| | | | |
|----|--------------------------|-----------------------|----|
| 62 | Front rear cover | 100*93*66 | 1 |
| 63 | Anti-loose nut | M6*1*6T | 1 |
| 64 | Nylon washer | D6*D19*1.5T | 1 |
| 65 | Flat washer | D13*D6.5*1.0T | 1 |
| 66 | Flat washer | D16xD8.5x1.2T | 18 |
| 67 | Bolt | M6x1.0x15L | 4 |
| 68 | Anti-loose nut | M6x1.0x6T | 4 |
| 69 | Bearing | #6003ZZ | 2 |
| 70 | Foam | D23*4T*415L | 2 |
| 71 | Foam | D23*4T*500L,with hole | 2 |
| 72 | Screw | ST4x1.41x10.L | 2 |
| 73 | Square cap | 25*25*13L | 2 |
| 74 | Handle pulse | PE18 | 2 |
| 75 | Rear protective cover | 100*93*66 | 1 |
| 76 | Flat washer | D23*D17.2*1.5T | 1 |
| 77 | Bolt | M8*25 | 1 |
| 78 | Spacer ring | D22.5*D17.2*6.4T | 1 |
| 79 | Spring | D2.2*D14*65L | 1 |
| 80 | Inner tube | 40*80*102L | 2 |
| 81 | Anti-loose nut | M10x1.5x10T | 1 |
| 82 | Bolt | M5x0.8x12L | 1 |
| 83 | Bolt | M8*52L | 1 |
| 84 | Anti-loose nut | M8*1.25*8T | 2 |
| 85 | Nut | M8*1.25*6T | 1 |
| 86 | Backrest supporting tube | | 1 |
| 87 | Bolt | M5*0.8*10L | 4 |
| 88 | Lower computer cable | 1200L | 1 |
| 89 | Screw | ST4.2*1.4*15L | 4 |
| 90 | Screw | ST4.2x1.4x20L | 13 |
| 91 | Pin | D6*26.5*7.7 | 4 |
| 92 | Buffer | 20*90*1.7T | 4 |
| \ | Allen wrench | M6 | 1 |
| \ | Spanner | 121*D6 | 1 |

8.3 Exploded Drawing

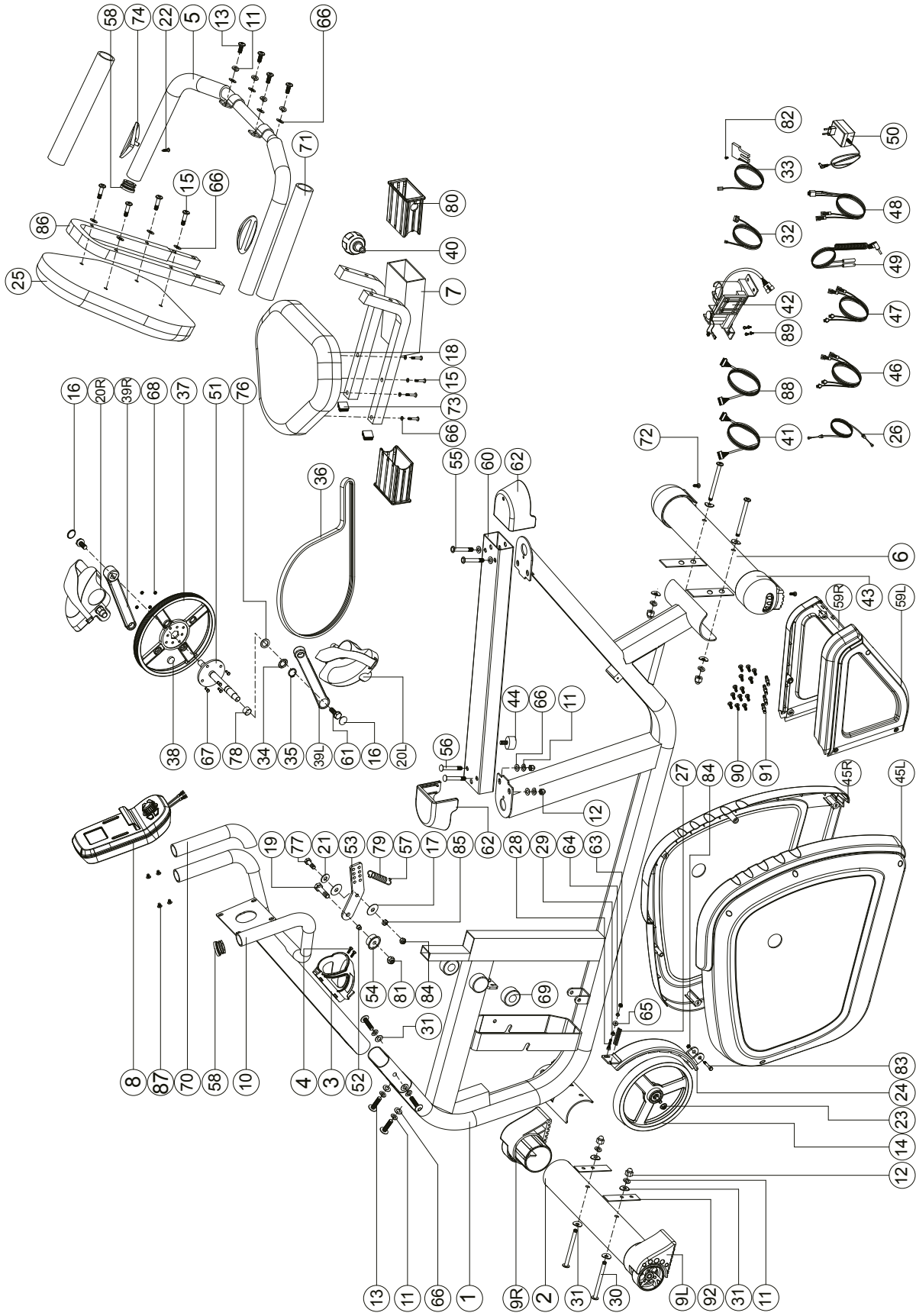

Training equipment from Taurus® is subject to strict quality control. However, if a fitness equipment purchased from us does not work perfectly, we take it very seriously and ask you to contact our customer service as indicated. We are happy to help you by phone via our service hotline.

Error Descriptions

Your fitness equipment is developed for long-term, high-quality training. However, should a problem arise, please first read the operating instructions. For further assistance, please contact your contract partner or call our service hotline. To ensure your problem is solved as quickly as possible, please describe the defect as exactly as possible.

In addition to the statutory warranty, we provide a warranty for every fitness equipment purchased from us according to the following provisions.

Your statutory rights are not affected.

Warranty

The warranty is the first/original buyer and/or any person who received a newly purchased product as a gift from the original buyer.

Warranty period

The warranty periods, shown on our web shop, begin on delivery of the fitness equipment. The respective warranty periods for your equipment can be found on its product website.

Repair Costs

According to our choice, there will either be a repair, a replacement of individual damaged parts or a complete replacement. Spare parts, that have to be mounted while assembling the equipment, have to be replaced by the warranty personally and are not a part of repair. After the expiration of the warranty period for repair costs, a pure parts warranty applies, which does not include the repair, installation and delivery costs.

The terms of use are defined as follows:

- + Home use: solely for private use in private households up to 3 hours per day
- + Semi-professional use: up to 6 hours per day (e. g. rehabilitation centres, hotels, clubs, company gyms)
- + Professional use: more than 6 hours per day (e. g. commercial gyms)

Warranty Service

Within the warranty period, equipment which develops faults as a result of material or manufacturing defects, will be repaired or replaced at our discretion. Ownership of equipment or parts of equipment which have been replaced is transferred to us. The warranty period is not extended nor does a new warranty period begin following repair or replacement under the warranty.

Warranty Service

Within the warranty period, equipment which develops faults as a result of material or manufacturing defects, will be repaired or replaced at our discretion. Ownership of equipment or parts of equipment which have been replaced is transferred to us. The warranty period is not extended nor does a new warranty period begin following repair or replacement under the warranty.

Warranty Conditions

For the warranty to be valid, the following steps must be taken:

Please contact our customer service by email or phone. If the product under warranty has to be sent in for repair, the seller bears costs. After expiry of the warranty, the buyer bears the costs of transport and insurance. If the fault is covered by our warranty, you will receive a new or repaired equipment in return.

Warranty claims are invalid in case of damage resulting from:

- + misuse or improper handling
- + environmental influences (moisture, heat, electrical surge, dust, etc.)
- + failure to follow the current safety measures for the equipment
- + failure to follow the operating instructions
- + use of force (e. g. hitting, kicking, falling)
- + interventions which were not carried out by one of our authorized service centres
- + unauthorised repair attempts

Proof of Purchase and Serial Number

Please make sure that you are able to provide the appropriate receipt when claiming on your warranty. So that we can clearly identify the model of your equipment, and for the purposes of our quality control, you will need to give the serial number of your equipment, when contacting the service team. Where possible please have your serial number and your customer number ready when you call our service hotline. It will help us to deal with your request swiftly.

If you cannot find the serial number on your fitness equipment, our service team is at your disposal to offer further information.

Service outside of the Warranty Period

We are also happy to issue an individual cost estimate if there is a problem with your fitness equipment after the warranty has expired, or in cases which do not fall under the terms of the warranty, e. g. normal wear and tear. Please contact our customer service team to find a quick and cost-effective solution to your problem. In such a case you will be responsible for the delivery costs.

Communication

Many problems can be solved just by speaking to us as your specialist supplier. We know how important it is to you as a user of the fitness equipment to have problems solved quickly and simply, so you can enjoy working out with minimal interruption. For that reason, we also want to resolve your queries quickly and in a straightforward manner. Thus, please always keep your customer number and the serial number of the faulty equipment handy.

| DE | | DK | | FR | | | |
|--|--|--|--|---|--|----|--|
| TECHNICAL SUPPORT +49 4621 4210-900 +49 4621 4210-698 technik@sport-tiedje.de Mo - Fr 08:00 - 18:00 Sa 09:00 - 18:00 | | TECHNICAL SUPPORT & SERVICE 80 90 16 50 +49 4621 4210-945 info@fitshop.dk Mo - Fr 08:00 - 18:00 Sa 09:00 - 18:00 | | TECHNICAL SUPPORT & SERVICE +33 (0) 172 770033 +49 4621 4210-933 service-france@fitshop.fr Mo - Fr 08:00 - 18:00 Sa 09:00 - 18:00 | | | |
| SERVICE 0800 20 20277 (Freecall) info@sport-tiedje.de Mo - Fr 08:00 - 21:00 Sa 09:00 - 21:00 So 10:00 - 18:00 | | <th colspan="2">PL</th> | | PL | | | |
| | | TECHNICAL SUPPORT & SERVICE 22 307 43 21 +49 4621 42 10-948 info@fitshop.pl Mo - Fr 08:00 - 18:00 Sa 09:00 - 18:00 | | <th colspan="2">BE</th> | | BE | |
| | | | | TECHNICAL SUPPORT & SERVICE 02 732 46 77 +49 4621 42 10-932 info@fitshop.be Mo - Fr 08:00 - 18:00 Sa 09:00 - 18:00 | | | |

| UK | | NL | | INT | | | |
|---|--|--|--|---|--|----|--|
| TECHNICAL SUPPORT +44 141 876 3986 support@powerhousefitness.co.uk | | TECHNICAL SUPPORT & SERVICE +31 172 619961 info@fitshop.nl Ma - Do 09:00 - 17:00 Vr 09:00 - 21:00 Za 10:00 - 17:00 | | TECHNICAL SUPPORT & SERVICE +49 4621 4210-944 service-int@sport-tiedje.de Mo - Fr 8am - 6pm Sat 9am - 6pm | | | |
| SERVICE +44 141 876 3972 Mo - Fr 9am - 5pm | | <th colspan="2">AT</th> | | AT | | | |
| | | TECHNICAL SUPPORT & SERVICE 0800 20 20277 (Freecall) +49 4621 42 10-0 info@sport-tiedje.at Mo - Fr 08:00 - 18:00 Sa 09:00 - 18:00 | | <th colspan="2">CH</th> | | CH | |
| | | | | TECHNICAL SUPPORT & SERVICE 0800 202 027 +49 4621 42 10-0 info@sport-tiedje.ch Mo - Fr 08:00 - 18:00 Sa 09:00 - 18:00 | | | |

Please find a detailed overview including address and opening hours for all stores of the Sport-Tiedje Group in Germany and abroad on the following website:

www.sport-tiedje.com/en/stores

WE LIVE FITNESS

WEBSHOP AND SOCIAL MEDIA

Sport-Tiedje is Europe's largest specialist store for home fitness equipment with currently 80 stores and one of the world's most renowned online mail order companies for fitness equipment. Private customers order via the 25 web shops in the respective national language or have their desired equipment assembled on site. In addition, the company supplies fitness studios, hotels, sports clubs, companies and physio practices with professional equipment for endurance and strength training.

Sport-Tiedje offers a wide range of fitness equipment from renowned manufacturers, high-quality in-house developments and comprehensive services, such as a build-up service and sports scientific advice before and after the purchase. The company employs numerous sports scientists, fitness trainers and competitive athletes.

Visit us also on our social media platforms or our blog!

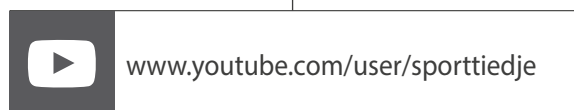
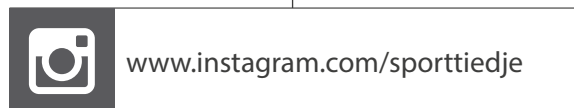
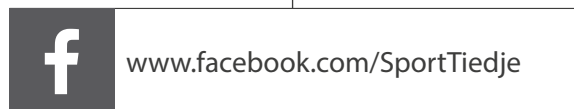



DARWIN **RB40**