



Assembly Instructions



max. 125 kg



~ 60 Min.



50 kg

L 121 | W 54 | H 128

FSDFSC30.01.01

Art. No. DF-SC30

DARWIN Indoor Cycle Evo 30

Content

1	GENERAL INFORMATION	8
1.1	Technical Data	8
1.2	Personal Safety	9
1.3	Set-Up Place	10
2	ASSEMBLY	11
2.1	General Instructions	11
2.2	Scope of Delivery	12
2.3	Assembly	14
2.4	Adjustments	19
2.4.1	Adjusting the Tension	19
2.4.2	Using the Emergency Brake Function	19
2.4.3	Adjusting the Handlebar	20
2.4.4	Adjusting the Seat	20
3	STORAGE AND TRANSPORT	21
3.1	General Instructions	21
3.2	Transportation Wheels	21
4	TROUBLESHOOTING, CARE AND MAINTENANCE	22
4.1	General Instructions	22
4.2	Faults and Fault Diagnosis	22
4.3	Maintenance and Inspection Calendar	23
4.4	Lubricating the Brake	23
5	DISPOSAL	24
6	RECOMMENDED ACCESSORIES	25
7	ORDERING SPARE PARTS	26
7.1	Serial Number and Model Name	26
7.2	Parts List	27
7.3	Exploded Drawing	29
8	WARRANTY	30
9	CONTACT	32

Dear customer,

thank you for choosing Darwin Fitness® equipment. With Darwin fitness equipment we offer first class home sports equipment at a great price point. Darwin exercise bikes and strength machines are easy to use, have a space-saving design and look really good. With our equipment we want to support you in reaching your athletic goals, no matter if you want to lose weight or train for the national triathlon. If you have any further questions, please contact us, we are looking forward to hearing from you and wish you lots of fun during your training!

Further information can be found at www.fitshop.com.

Intended Use

The equipment may only be used for its intended purpose.

The equipment is only suitable for home use. The equipment is not suitable for semi-professional (e.g. hospitals, associations, hotels, schools, etc.) and commercial or professional use (e.g. fitness studios).

Legal Notice

Fitshop GmbH
Europe's No. 1 for home fitness

International Headquarters
Flensburger Straße 55
24837 Schleswig
Germany

Management:
Christian Grau
Sebastian Campmann
Dr. Bernhard Schenkel
No. HRB 1000 SL
Local Court Flensburg
European VAT Number: DE813211547

Disclaimer

© Darwin Fitness is a registered brand of the company Fitshop GmbH. All rights reserved. Any use of this trademark without the explicit written permission of Fitshop is prohibited.

Product and manual are subject to change. Technical data can be changed without advance notice.

FITSHOP

Europe's No.1 for Home Fitness

ABOUT THIS MANUAL

Please carefully read the entire manual before installation and first use. The manual will help you to quickly set up the system and explains how to safely use it. Make sure that all persons exercising with the equipment (especially children and persons with physical, sensory, mental or motor disabilities) are informed about this manual and its contents in advance. In case of doubt, responsible persons must supervise the use of the equipment.



Due to ongoing changes and software optimisations, the manual may have to be updated. If you notice any discrepancies during assembly or use, please refer to the manual uploaded to the webshop. The latest manual is always available there.

This equipment has been manufactured according to the latest safety knowledge. As far as possible, potential safety hazards which could cause injury have been eliminated. Make sure to carefully follow the instructions and that all parts are securely in place. If required, read through the instructions again to correct any mistakes.

Training devices must be classified according to accuracy and use. Accuracy classes are only applicable to devices that display training data.

Accuracy classes

Class A: high accuracy.

Class B: medium accuracy.

Class C: low accuracy.

The use classes explain the intended use of the training device.

Use classes

Class S (studio): professional and/or commercial use.

These training devices are intended for the use in training rooms of facilities such as sports clubs, school facilities, hotels, clubs and studios whose access and supervision is specifically regulated by the owner (person with legal responsibility).

Class H (home use): use at home.

These stationary training devices are intended for the use in private homes where access to the training device is regulated by the owner (person with legal responsibility).

Please pay close attention to the safety and maintenance instructions given here. The contract partner cannot be held liable for damage to health, accidents or damage to the equipment when it is not used in accordance with these instructions.

The following safety instructions may appear in this manual:

► **ATTENTION**

This notice indicates potentially hazardous situations which, if not avoided, may result in property damage.

⚠ **CAUTION**

This notice indicates potentially hazardous situations which, if not avoided, may result in slight or minor injuries!

⚠ **WARNING**

This notice indicates potentially hazardous situations which, if not avoided, may result in death or serious injuries!

⚠ **DANGER**

This notice indicates potentially hazardous situations which, if not avoided, will result in death or serious injuries!

ⓘ **NOTICE**

This notice indicates further useful information.

Retain these instructions in a safe place for future reference, maintenance or when ordering replacement parts.

1.1 Technical Data

Brake system: Friction brake
Flywheel mass: 21 kg

Weight and Dimensions

Product weight (gross, incl. packaging) approx.: 54 kg

Product weight (net, without packaging) approx.: 50 kg

Packaging dimensions (L x W x H) approx. 108 cm x 92 cm x 20 cm

Set-up dimensions (L x W x H) approx.: 121 cm x 54 cm x 128 cm

Maximum user weight: 125 kg

Use class: H (home use)

1.2 Personal Safety

DANGER

- + Before you start using the equipment, you should consult your physician that this type of exercise is suitable for you from a health perspective. Particularly affected are persons who: have a hereditary disposition to high blood pressure or heart disease, are over the age of 45, smoke, have high cholesterol values, are overweight and/or have not exercised regularly in the past year. If you are under medical treatment that affects your heart rate, medical advice is absolutely essential.
- + Note that excessive training can seriously endanger your health. Please also note that heart rate monitoring systems can be inaccurate. If you notice any signs of weakness, nausea, dizziness, pain, shortness of breath, or other abnormal symptoms, stop exercising immediately and seek advice from your doctor if necessary.
- + The owner must communicate all warnings and instructions to the user.

WARNING

- + This equipment may not be used by children under the age of 14.
- + Children should not be allowed unsupervised access to the equipment.
- + Persons with disabilities must have a medical license and must be under strict observation when using the equipment.
- + The equipment is strictly for use by one person at a time.
- + If your equipment provides a safety key, the clip of the safety key must be attached to your clothing before starting your training. In the event of a fall, the EMERGENCY STOP of the equipment can be initiated.
- + There is a risk of injury from spinning pedals and/or an exposed flywheel in the absence of a freewheel. Never get on or off the equipment when the pedals or the flywheel are still moving. Always make sure that the pedals and the flywheel have come to a complete stop.
- + Support yourself with at least one hand on the handlebar when getting on and off the equipment. Only dismount from the equipment when the pedals have come to a complete stop.
- + Keep your hands, feet and other body parts, hair, clothing, jewellery and other objects well clear of moving parts.
- + During use, wear suitable sports clothing rather than loose or baggy clothing. When wearing sports shoes, make sure they have suitable soles, preferably made of rubber or other non-slip materials. Shoes with heels, leather soles, studs or spikes are unsuitable. Never exercise barefoot.

CAUTION

- + If your equipment needs to be connected to the power supply with a mains cable, make sure that the cable is not a potential tripping hazard.
- + Make sure that nobody is within the range of motion of the equipment during training so as not to endanger you or other persons.
- + Always tighten the pedal strap before you start training to prevent your feet from slipping.

⚠ CAUTION

- + Be aware that if adjustment devices are left protruding, they may impede the user's movement.

▶ ATTENTION

- + Do not insert any objects of any kind into the openings of the device.
- + To protect the equipment from use by unauthorised third parties, always remove the power cable (if existing) when not in use and store it in a safe place that is inaccessible to unauthorised persons (e.g. children).
- + Class B and C crank training equipment is not suitable for high accuracy purposes.

1.3 Set-Up Place

⚠ WARNING

- + Do not place the equipment in main corridors or escape routes.

⚠ CAUTION

- + Choose a location in which to place the equipment such that there is enough free space/clearance to the front, the rear and to the sides of the equipment.
- + The training room should be well ventilated during training and not be exposed to any draughts.
- + Choose the place in which to set up the equipment such that there is enough free space/clearance to the front, the rear and to the sides of the equipment.
- + The free area in the direction from which the exercise equipment is accessed must be at least 0.6 m larger than the exercise area.
- + The set-up and mounting surface of the equipment should be flat, loadable and solid.

▶ ATTENTION

- + The device may only be used in one building, in sufficiently tempered and dry rooms (ambient temperatures between 10°C and 35°C). The equipment should not be used outdoors or in rooms with high humidity (over 70%) like swimming pools.
- + A floor protective mat/equipment underlay can help to protect high-quality floor coverings (parquet, laminate, cork, carpets) from dents and sweat and can help to level out slight unevenness.
- + For Class S equipment, the exercise equipment may only be used in areas where access, supervision and control are specifically regulated by the owner.

2.1 General Instructions

DANGER

- + Do not leave any tools, packaging materials such as foils or small parts lying around, as otherwise there is a danger of suffocation for children. Keep children away from the equipment during assembly.

WARNING

- + Pay attention to the instructions attached to the equipment in order to reduce the risk of injuries.

CAUTION

- + Ensure to have sufficient room for movement in each direction during assembly.
- + The assembly of the equipment must be carried out by at least two adults. If in doubt, seek the help of a third technically skilled person.

ATTENTION

- + To prevent damage to the equipment and the floor, assemble the equipment on a mat or packaging board.

NOTICE





- + In order to make the assembly as simple as possible, some screws and nuts to be used can already be pre-assembled.
- + Ideally, assemble the equipment at its later set-up place.





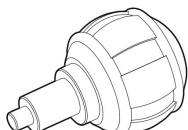
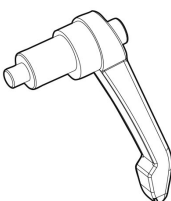
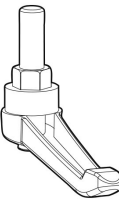

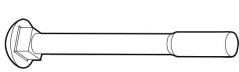
2.2 Scope of Delivery

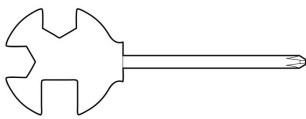
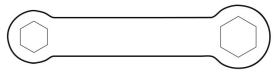
The scope of delivery consist of the following parts. At the beginning, check whether all parts and tools belonging to the device are included in the scope of delivery and whether damage has occurred. In the event of complaints, the contractual partner must be contacted directly.

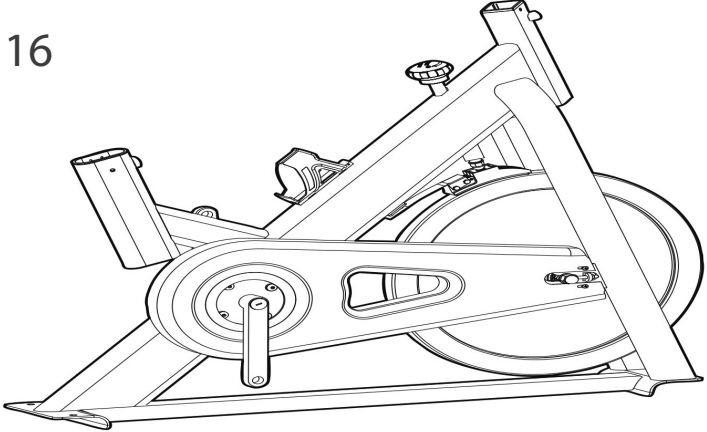
CAUTION

If parts of the scope of delivery are missing or damaged, the assembly must not be carried out.

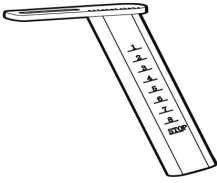
7		Spring adjustment knob	1
19		L shape knob, M16x20	1
23		L shape knob, M16x25	2
22		Flat washer 1, ø45xø10.5x4	2
3		Carriage bolt, M8x52	4
6		Domed nut, M8	4
5		Flat washer, ø8	4
		Allen wrench	1
		Spanner	1

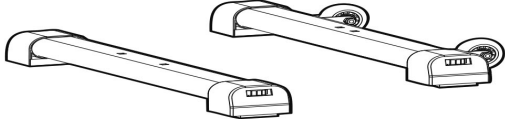
<p>16</p> 	<p>Main frame</p>
<p>12</p> 	<p>Seat post</p>
<p>13</p> 	<p>Seat</p>
<p>17</p> 	<p>Handlebar post</p>
<p>10</p> 	<p>Vertical seat post</p>
<p>18</p> 	<p>Handle bar</p>
<p>1L / 1R</p> 	<p>Pedals, left & right</p>
<p>15 / 4</p> 	<p>Front & rear stabilizers</p>

2.3 Assembly

Before assembly, take a close look at the individual assembly steps shown and carry out the assembly in the order given.

① NOTICE

- + First loosely screw all parts together and check that they fit properly. Tighten the screws using the tool only when you are instructed to do so.
- + If you have difficulty recognising the graphics, we recommend that you open and/or download the PDF instructions stored in the webshop on your end device (e.g. smartphone, tablet or PC). There you have the option of zooming in closer. Please note that the Adobe Acrobat Reader programme must be installed on your end device in order to open the file.
- + The assembly can also be found as a video under the following link: <https://www.youtube.com/watch?v=Yx2EIQRa6iw> To go directly to the assembly video, you can alternatively scan the QR code.



Step 1: Assembly of the Front and Rear Stabilizers

1. Assemble the front stabilizer (15) to the main frame (16) using mit two flat washers (5), two domed nuts (6) and two carriage bolts (3).
2. Assemble the rear stabilizer (4) to the main frame (16) using two flat washers (5), two domed nuts (6) and two carriage bolts (3).

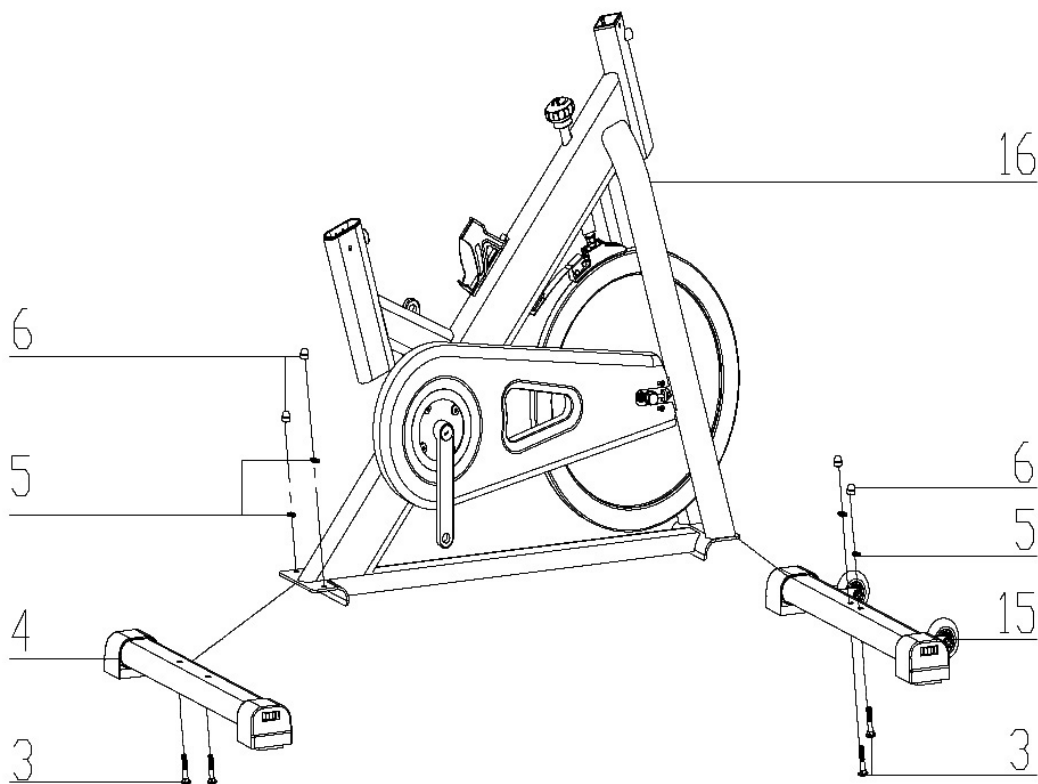

Step 2: Assembly of the Seat Posts and the Seat

1. Slide the vertical seat post (10) into the respective tube of the main frame (16).
2. Fix the vertical seat post (10) to the desired height with the spring adjustment knob (7).
3. Slide the seat post (12) on the vertical seat post (10) and fix it with the flat washer (22) and the L-shape knob (23).
4. Assemble the seat (13) to the seat post (12)
5. Tighten the screws underneath the seat (13).

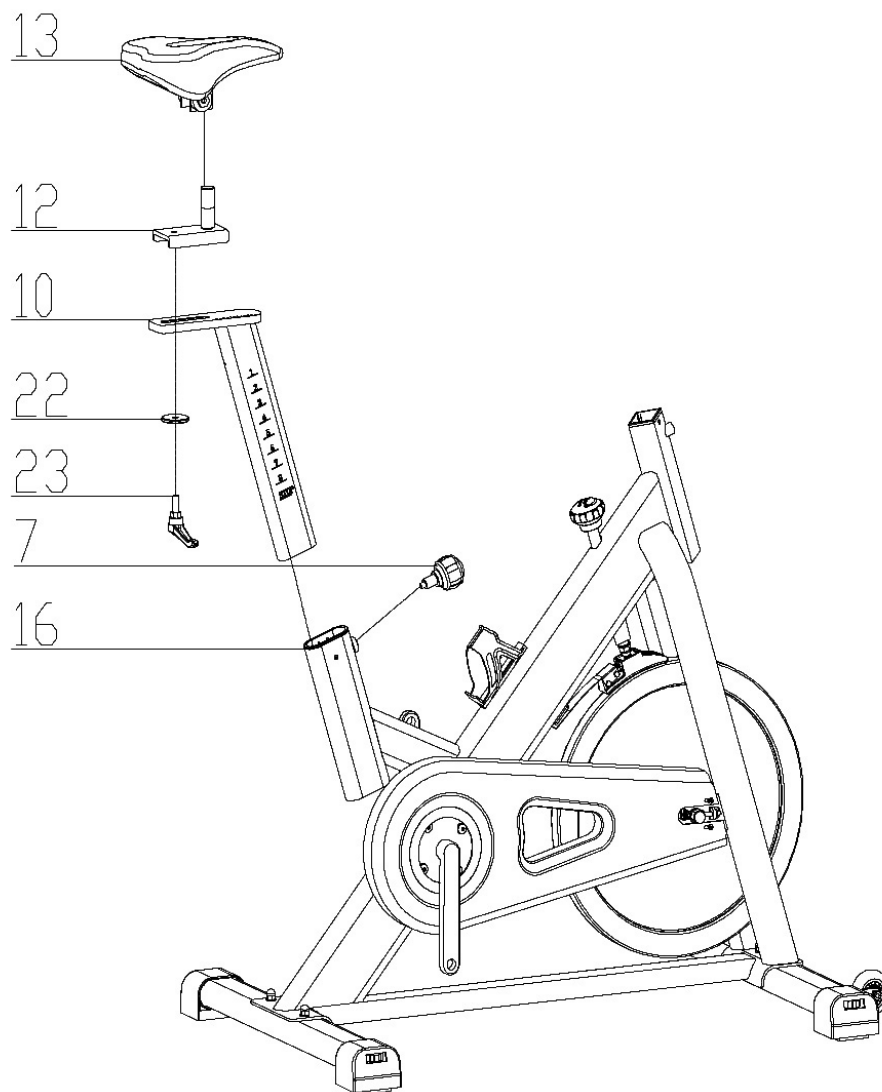

Step 3: Assembly of the Handlebar Post and Handlebar

1. Slide the handlebar post (17) into the respective tube of the main frame (16).
2. Loosen the L-shape knob (19) and pull it out a bit.
3. Position the handlebar post (17) to the desired height.
4. Fix the position by letting go of the L shape knob (19) again and make sure it has engaged in one of the pre-drilled holes of the handlebar post (17).
5. Tighten the L shape knob (19) again.
6. Mount the handlebar (18) on the handlebar post (17) with the L-shape knob (23) and one washer (22).

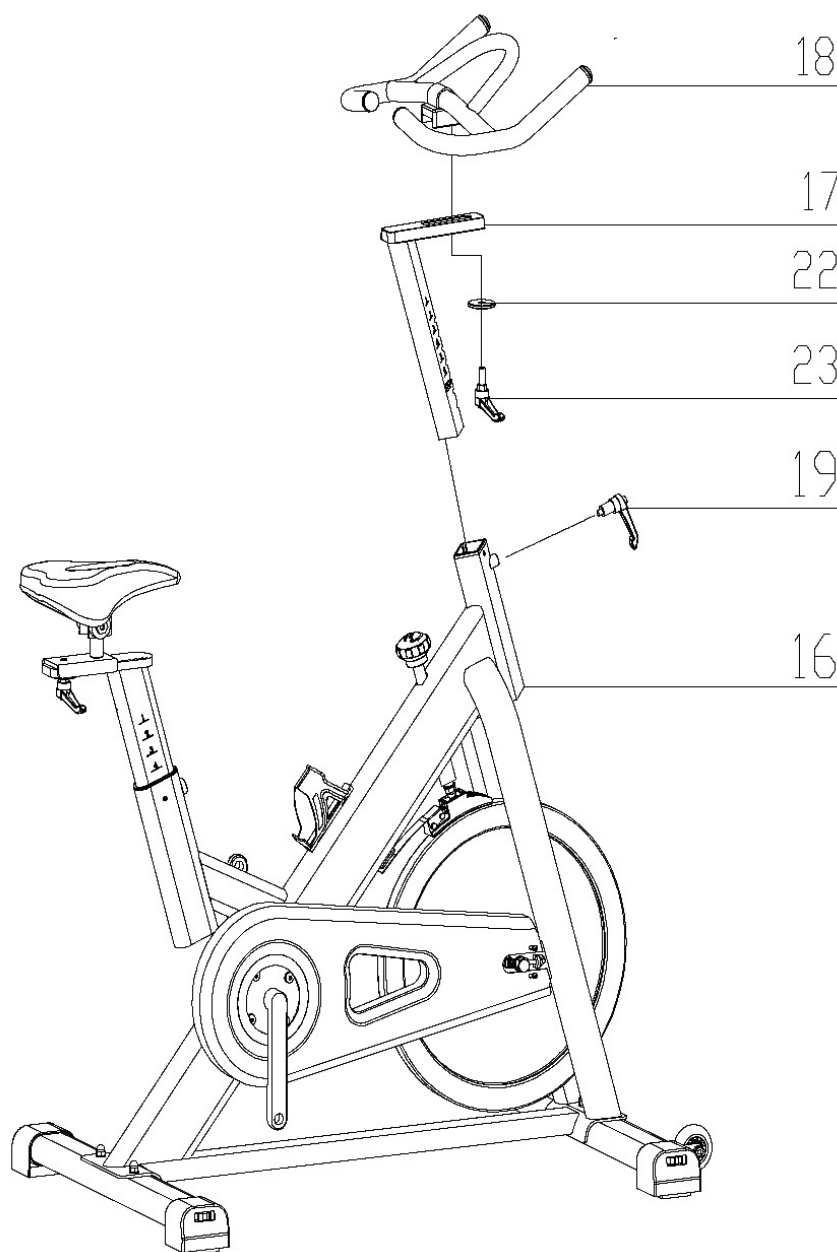

Step 4: Assembly of the Pedals

① **NOTICE**

The pedals are marked with "R" and "L" for right and left.

1. Assemble the right pedal (1R) to the right crank (36) by rotating it clockwise.
2. Assemble the left pedal (1L) to the left crank (33) by rotating it counterclockwise.

⚠ **WARNING**

Make sure to screw in the pedals completely.

3. Tighten all screw joints.

→ *The assembly of the equipment is now completed.*

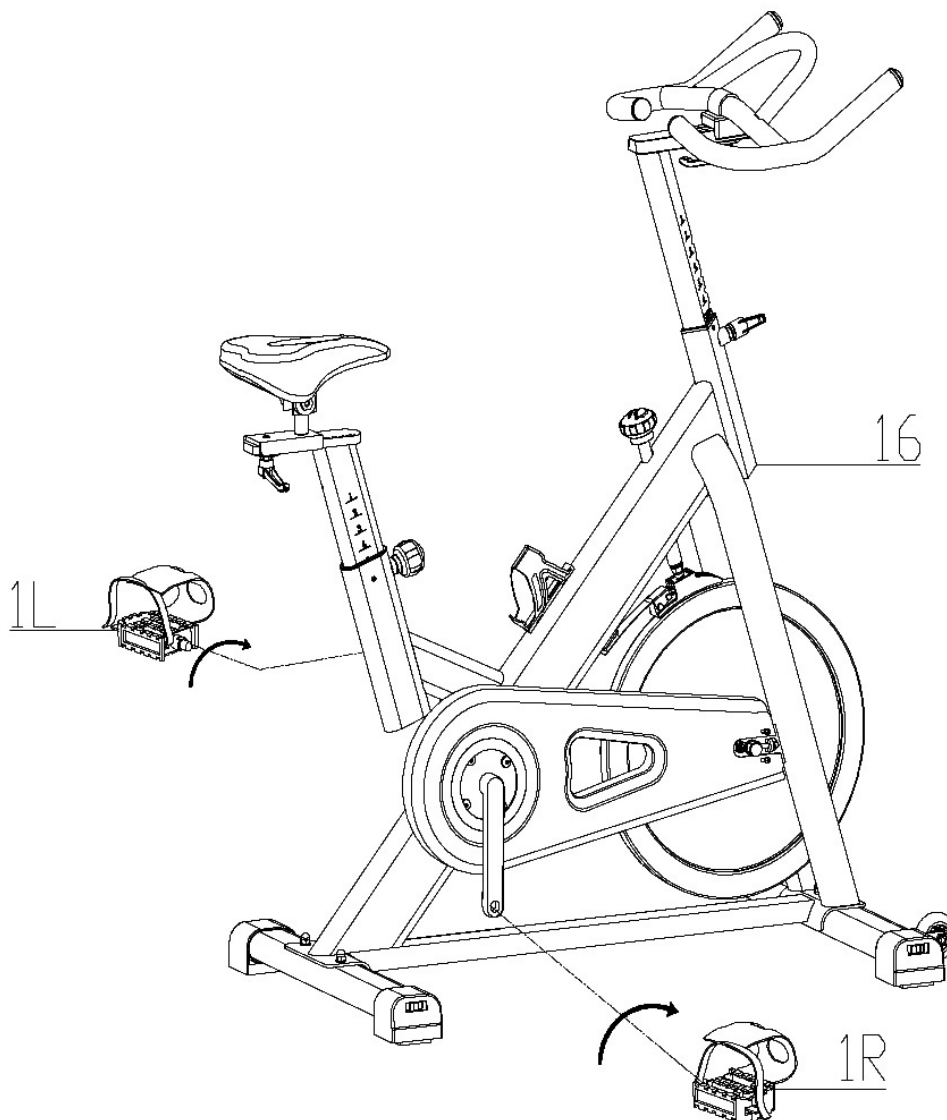

Step 5: Alignment of the feet

If the floor is uneven, you can stabilize the equipment by turning the two setting screws under the main frame.



CAUTION

The setting screws should always be turned in as far as possible and not be turned out more than 1 cm.

1. Lift the equipment on the desired side and rotate the setting screws under the main frame.
2. Rotate the screws clockwise in order to remove them and to raise the equipment.
3. Rotate them counterclockwise in order to lower the equipment.

2.4 Adjustments

2.4.1 Adjusting the Tension

The brake resistance can be adjusted with the knob (30).

1. To increase the brake resistance turn the knob (30) clockwise.
2. To decrease the brake resistance turn the knob (30) counterclockwise.

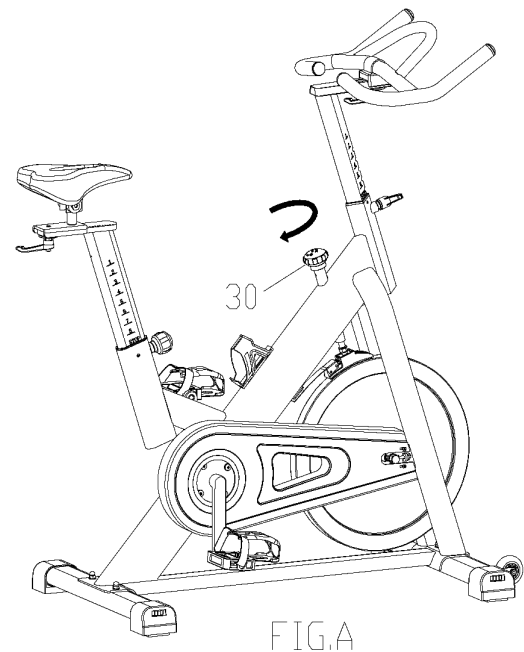

2.4.2 Using the Emergency Brake Function

⚠ WARNING

Use this safety feature in any emergency situation where you need to get off the indoor cycle or bring the flywheel to a standstill.

The lever for adjusting the resistance level (30) is also the emergency brake. If you want to stop the device quickly, press the knob all the way down.

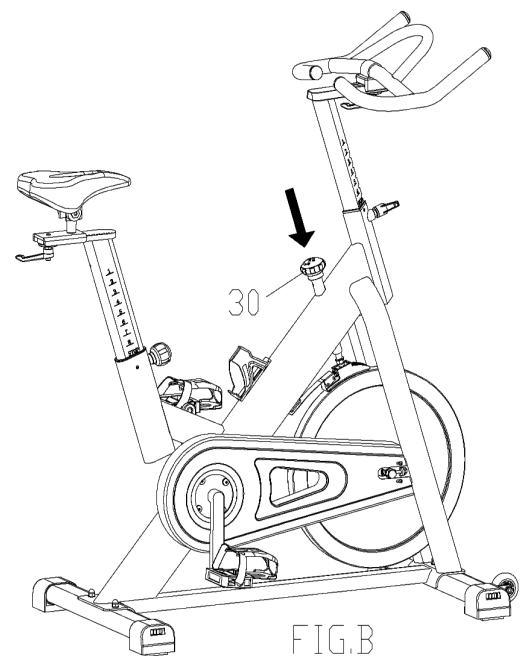

2.4.3 Adjusting the Handlebar

The handlebar can be adjusted horizontally and vertically.

1. To adjust the handlebar in the vertical position, loosen the L shape knob (19) and pull it backwards.



CAUTION

Make sure that the L shape knob audibly engages in one of the adjustment holes.

2. Let go of the L shape knob (19) again and make sure that it is engaged in one of the pre-drilled holes of the handlebar post (17).
3. Now tighten the L shape knob (19) again.
4. To adjust the handlebar in the horizontal position, loosen the L shape knob (23) and pull it downwards.
5. Now bring the handlebar (18) to the desired position.



CAUTION

Make sure that the L shape knob audibly engages in one of the adjustment holes.

6. Let go of the L shape knob (23) again and make sure that it is engaged in one of the pre-drilled holes of the handlebar post (17).
7. Now tighten the L shape knob (23) again.

2.4.4 Adjusting the Seat

The seat can be adjusted horizontally and vertically.

1. To adjust the vertical position of the seat, loosen the knob (7) on the seat tube of the main frame (16) and pull it out slightly.
2. Now bring the vertical seat post (10) to the desired height.



CAUTION

Make sure that the knob audibly engages in one of the adjustment holes.

3. Let go of the knob (7) and make sure that it is engaged in one of the pre-drilled holes of the vertical seat post (10).
4. Now tighten the knob (7) again.
5. To adjust the horizontal position of the seat, loosen the L-shape knob (23) and pull it down slightly.
6. Now bring the seat post (12) and the seat (13) to the desired position.



CAUTION

Make sure that the knob audibly engages in one of the adjustment holes.

7. Let go of the L-shape knob (23) and be sure it is engaged in one of the pre-drilled holes of the seat post (12).
8. Now tighten the L-shape knob (23) again.

3.1 General Instructions

⚠ WARNING

- + The storage location should be chosen so that improper use by third parties or children can be prevented.
- + If your equipment does not have transportation wheels, the equipment must be disassembled before transportation.

▶ ATTENTION

- + Make sure that the equipment is protected from moisture, dust and dirt in the selected storage location. The storage location should be dry and well ventilated and have a constant ambient temperature between 10°C and 35°C.

3.2 Transportation Wheels

▶ ATTENTION

If you want to transport your equipment over particularly sensitive and soft floor coverings, such as parquet, planks or laminate, lay out the transport route with cardboard or similar to avoid possible floor damage.

1. Stand behind the equipment and lift it until the weight is transferred to the transportation wheels. After that, you easily can move the equipment to a new position. For long transport distances the equipment should be disassembled and safely packed.
2. Select the new location by following the instructions in the section 1.3 of this manual.

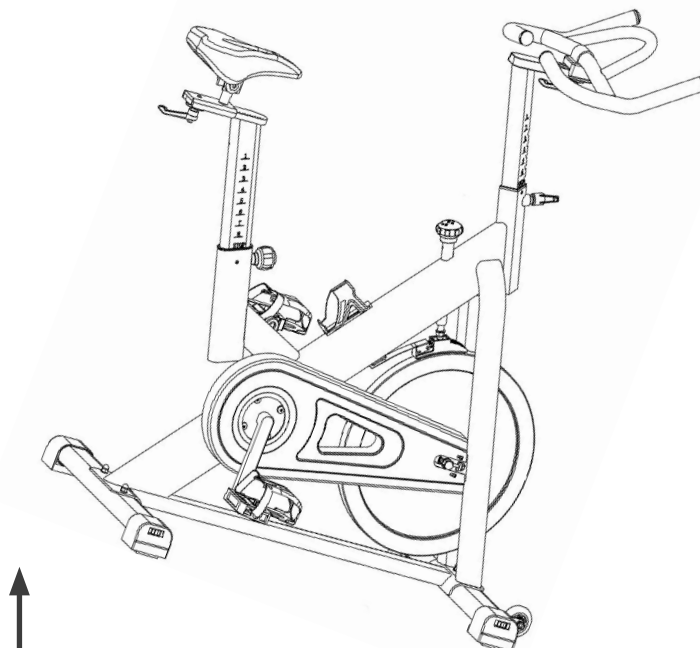

4.1 General Instructions

WARNING

- + Do not make any improper changes to the equipment.

CAUTION

- + Damaged or worn components may affect your safety and the life of the equipment. Therefore, immediately replace damaged or worn components. In such a case, contact the contract partner. The equipment must not be used until it has been repaired. If necessary, use only original spare parts.

ATTENTION

- + In addition to the instructions and recommendations for maintenance and care given here, additional service and/or repair work may be necessary; this must only be carried out by authorised service technicians.

4.2 Faults and Fault Diagnosis

The equipment undergoes regular quality controls during production. Nevertheless, faults or malfunctions may occur. Frequently, individual parts are responsible for these disturbances, an exchange is usually sufficient. Please refer to the following overview for the most common errors and how to correct them. If the equipment still does not function properly, contact your contract partner.

Fault	Cause	Solution
Cracking in the pedal area	Pedals loose	Tighten the pedals
Equipment wobbles	Equipment is not level	Align the feet
Handlebar/saddle wobbles	Loose screws	Tighten screws firmly
Brake makes noises	Felt brake too dry	Moisten felt brake with silicone spray

4.3 Maintenance and Inspection Calendar

To avoid damage from body sweat, the equipment must be cleaned with a damp towel (no solvents!) after each training session.

The following routine tasks must be performed at the specified intervals:

Part	Weekly	Monthly
Display console	C	I
Plastic covers	C	I
Moisture of the brake		I
Screws and cable connections		I
Lubricate saddle/seat post with silicon gel		I
Check pedals for tightness		I
Legend: C = clean; I = inspect		

4.4 Lubricating the Brake

Lubrication is a highly important service activity.

The procedure is absolutely essential if the friction of the brake system increases noticeably. Increased friction is indicated by jerky movement in higher resistance levels.

► **ATTENTION**

To prevent damage to the device, make sure to keep the brake moist with lubricant at regular intervals. The information in the maintenance and inspection calendar is for reference only. Note that the brake must be lubricated more often when the device is used more frequently.

To lubricate the brake, apply one to two drops of silicone oil or some silicone spray to the flywheel and rotate the flywheel for two turns.



5 DISPOSAL

At the end of its operational life, this equipment cannot be disposed of in normal household waste. Instead, it must be disposed of via an electricals recycling centre. Further information can be obtained from your local authority's recycling service.

The materials can be recycled as per their symbols. Through the reuse, recycling of materials or other forms of recovery of old equipment, you make an important contribution to the protection of the environment.



6 RECOMMENDED ACCESSORIES

To make your training experience even more efficient and pleasant, we recommend that you add suiting accessories to your fitness equipment. For indoor cycles this could for example be a **floor mat**, which makes your fitness equipment stand more securely and also protects the floor from sweat or **silicone spray** to keep moving parts in good shape. For many indoor bikes it is possible to replace the **saddle** or **pedals**, as these are usually the same mounts used on bicycles.

If you have purchased a fitness machine with pulse training and want to train your heart rate, we strongly recommend that you use a compatible **chest strap**, as this ensures optimum transmission of the heart rate.

Our range of accessories offers the highest quality and makes training even better. If you would like to find out more about compatible accessories, please go to the detail page of the product in our webshop (the easiest way is to enter the article number in the search field above) and go to the recommended accessories on this page. Alternatively, you can use the QR code provided. Of course, you can also contact our customer service: by telephone, e-mail, in one of our branches or via our social media channels. We will be happy to advise you!



floor mat



chest strap



chest strap contact gel



pedals



saddle cover



silicone spray

7.1 Serial Number and Model Name

In order to provide you with the best possible service, please have the model name, article number, serial number, exploded drawing and parts list ready. The corresponding contact options can be found in chapter 9 of this operating manual.

ⓘ NOTICE

The serial number of your equipment is unique. The serial number and other information can be found on the typeplate on the equipment.

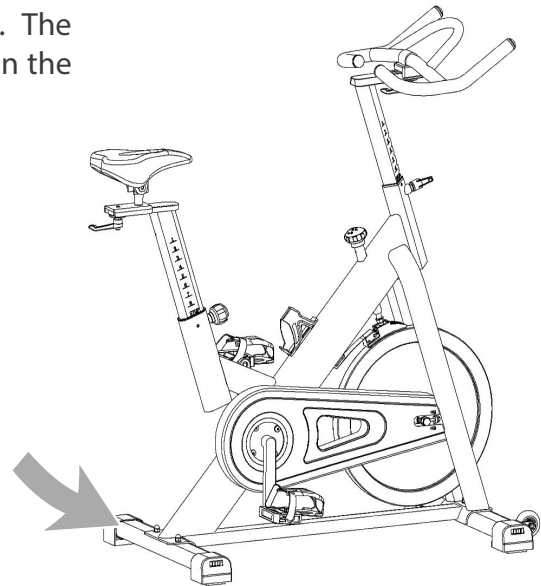

Enter the serial number in the appropriate field.

Serial number:

Brand / Category:

Darwin / Indoor Cycle

Model Name:

Evo 30

Article Number:

DF-SC30

7.2 Parts List

No.	Name	Qty.	No.	Name	Qty.
1L	PEDAL L	1	29	CRANK END CAP	2
1R	PEDAL R	1	30	KNOB	1
2	END CAP1	4	31	LOCK NUT	6
3	CARRIAGE BOLT	4	32	TWIST THE FIXINGS	1
4	REAR STABILIZER	1	33	LEFT CRANK	1
5	FLAT WASHER	4	34	CRANK COVER	1
6	DOMED NUT	4	35	BEARING	2
7	SPRING ADJUSTMENT KNOB	1	36	RIGHT CRANK	1
8	PLASTIC SLEEVE 1	1	37	NUT	2
9	BOLT 1	1	38	FIXING NUT 2	2
10	VERTICAL SEAT POST	1	39	FIXING BOLT	2
11	END CAP 2	1	40	NUT	2
12	SEAT POST	1	41	SCREW 1	13
13	SEAT	1	42	SCREW 2	7
14	FLAT WASHER	3	43	SCREW 3	2
15	FRONT STABILIZER	1	44	OUTER CHAIN COVER	1
16	MAIN FRAME	1	45	LITTLE CHAIN COVER	1
17	HANDLEBAR POST	1	46	AXIS	1
18	HANDLE BAR	1	47	LONG FIXING TUBE	1
19	L SHAPE KNOB	1	48	SHORT FIXING TUBE	1
20	BOTTLE HOLDER	1	49	INNER CHAIN COVER	1
21	PLASTIC SLEEVE 2	1	50	BELT	1
22	FLAT WASHER 1	2	51	BELT WHEEL	1
23	L SHAPE KNOB	2	52	WASHER 2	3
24	END CAP 3	1	53	SPRING 1	1
25	FLAT WASHER2	1	54	SCREW ROD	1
26	BOLT 2	2	55	BOLT	2
27	BOLT	4	56	PU WHEEL	2
28	FIXING NUT 1	2	57	BEARING	4

58	FIXING NUT 2	2	67	FLYWHEEL COVER	1
59	FIXING TUBE	1	68	SPRING COVER	1
60	BEARING	2	69	SPRING 3	1
61	FLYWHEEL	1	70	PLASTIC FRAME	1
62	FLYWHEEL SHAFT	1	71	LITTLE PLASTIC	1
63	SPRING WASHER 1	2	72	SPRING BRAKE	1
64	DOMED NUT	1	73	WOOLLY BLOCK	1
65	LOCK NUT	2	74	BOLT 1	2
66	FIXING NUT	2	75	WASHER 4	1

7.3 Exploded Drawing

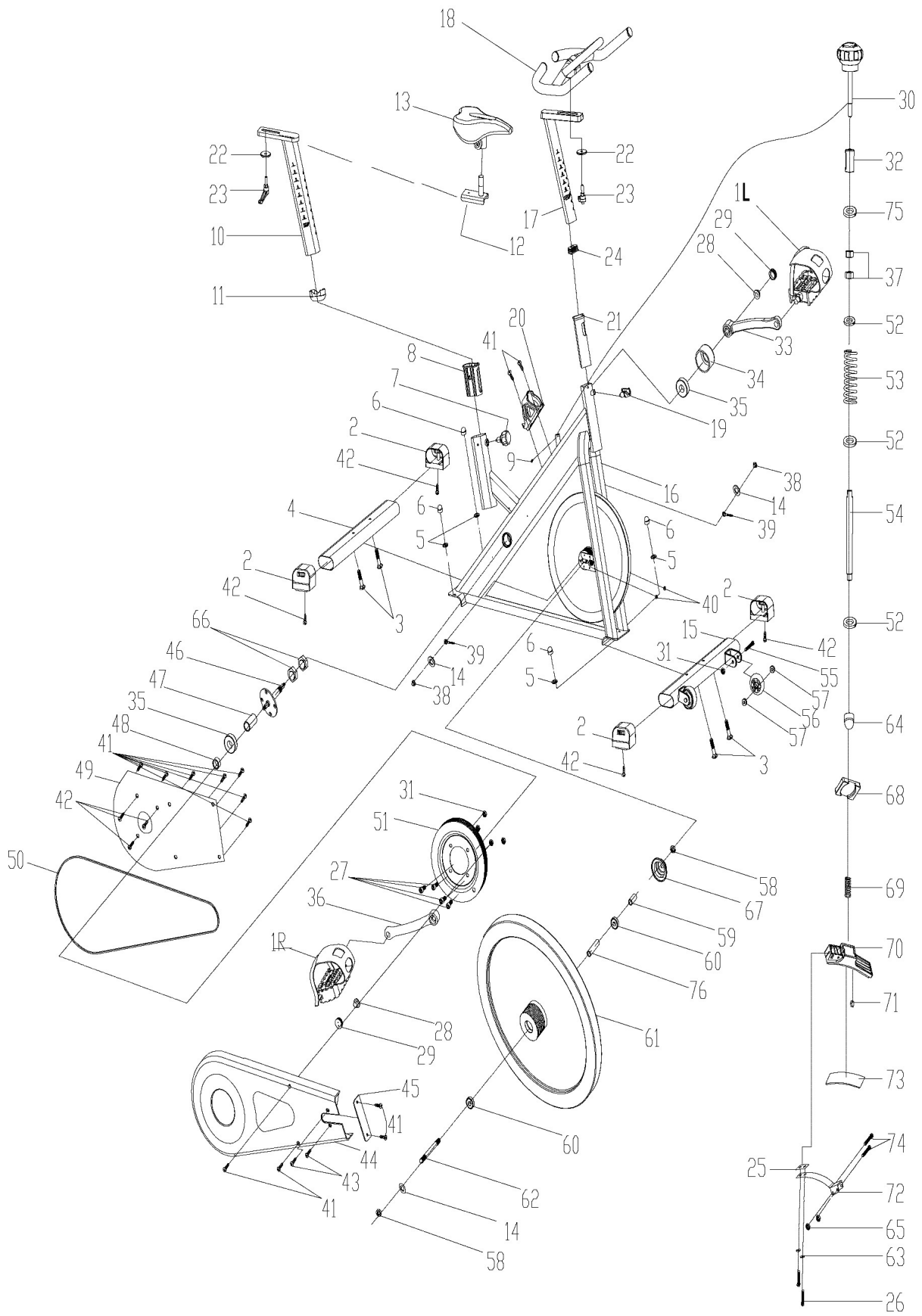

Products from Darwin Fitness® are subject to strict quality control. However, if a fitness equipment purchased from us does not work perfectly, we take it very seriously and ask you to contact our customer service as indicated. We are happy to help you by phone via our service hotline.

Error Descriptions

Your fitness equipment is developed for long-term, high-quality training. However, should a problem arise, please first read the operating instructions. For further assistance, please contact your contract partner or call our service hotline. To ensure your problem is solved as quickly as possible, please describe the defect as exactly as possible.

In addition to the statutory warranty, we provide a warranty for every fitness equipment purchased from us according to the following provisions.

Your statutory rights are not affected.

Warranty

The warranty is the first/original buyer and/or any person who received a newly purchased product as a gift from the original buyer.

Warranty period

The warranty periods, shown on our web shop, begin on delivery of the fitness equipment. The respective warranty periods for your equipment can be found on its product website.

Repair Costs

According to our choice, there will either be a repair, a replacement of individual damaged parts or a complete replacement. Spare parts, that have to be mounted while assembling the equipment, have to be replaced by the warranty holder personally and are not a part of repair. After the expiration of the warranty period, the responsibility for parts costs, repair costs, installation costs and delivery costs lies with the warranty holder.

The terms of use are defined as follows:

- + Home use: solely for private use in private households up to 3 hours per day
- + Semi-professional use: up to 6 hours per day (e. g. rehabilitation centres, hotels, clubs, company gyms)
- + Professional use: more than 6 hours per day (e. g. commercial gyms)

Warranty Service

Within the warranty period, equipment which develops faults as a result of material or manufacturing defects, will be repaired or replaced at our discretion. Ownership of equipment or parts of equipment which have been replaced is transferred to us. The warranty period is not extended nor does a new warranty period begin following repair or replacement under the warranty.

Warranty Conditions

For the warranty to be valid, the following steps must be taken:

Please contact our customer service by email or phone. If the product under warranty has to be sent in for repair, the seller bears costs. After expiry of the warranty, the buyer bears the costs of transport and insurance. If the fault is covered by our warranty, you will receive a new or repaired equipment in return.

Warranty claims are invalid in case of damage resulting from:

- + misuse or improper handling
- + environmental influences (moisture, heat, electrical surge, dust, etc.)
- + failure to follow the current safety measures for the equipment
- + failure to follow the operating instructions
- + use of force (e. g. hitting, kicking, falling)
- + interventions which were not carried out by one of our authorized service centres
- + unauthorised repair attempts

Proof of Purchase and Serial Number

Please make sure that you are able to provide the appropriate receipt when claiming on your warranty. So that we can clearly identify the model of your equipment, and for the purposes of our quality control, you will need to give the serial number of your equipment, when contacting the service team. Where possible please have your serial number and your customer number ready when you call our service hotline. It will help us to deal with your request swiftly.







































If you cannot find the serial number on your fitness equipment, our service team is at your disposal to offer further information.

Service outside of the Warranty Period

We are also happy to issue an individual cost estimate if there is a problem with your fitness equipment after the warranty has expired, or in cases which do not fall under the terms of the warranty, e. g. normal wear and tear. Please contact our customer service team to find a quick and cost-effective solution to your problem. In such a case you will be responsible for the delivery costs.

Communication

Many problems can be solved just by speaking to us as your specialist supplier. We know how important it is to you as a user of the fitness equipment to have problems solved quickly and simply, so you can enjoy working out with minimal interruption. For that reason, we also want to resolve your queries quickly and in a straightforward manner. Thus, please always keep your customer number and the serial number of the faulty equipment handy.

DE	DK	UK
<p>TECHNIK</p> <p> +49 4621 4210-900</p> <p> +49 4621 4210-698</p> <p> technik@fitshop.de</p> <p> Öffnungszeiten entnehmen Sie unserer Homepage.</p> <p>SERVICE</p> <p> 0800 20 20277 (kostenlos)</p> <p> 04621 4210 - 0</p> <p> info@fitshop.de</p> <p> Öffnungszeiten entnehmen Sie unserer Homepage: https://stg.fit/statita</p>	<p>TEKNIK OG SERVICE</p> <p> 80 90 16 50</p> <p>+49 4621 4210-945</p> <p> info@fitshop.dk</p> <p> Åbningstider kan findes på hjemmesiden: https://stg.fit/statit7</p>	<p>CUSTOMER SUPPORT</p> <p> 00800 2020 2772</p> <p>+494621 4210 944</p> <p> info@fitshop.co.uk</p> <p> You can find the opening hours on our homepage: https://stg.fit/statitc</p>
	FR	BE
	<p>TECHNIQUE & SERVICE</p> <p> +33 (0) 189 530984</p> <p>+49 4621 42 10 933</p> <p> info@fitshop.fr</p> <p> Vous trouverez les heures d'ouverture sur notre site Internet: https://stg.fit/statit4</p>	<p>TECHNIQUE & SERVICE</p> <p> 02 732 46 77</p> <p>+49 4621 4210 933</p> <p> info@fitshop.be</p> <p> Vous trouverez les heures d'ouverture sur notre site Internet: https://stg.fit/statit8</p>
ES	NL	INT
<p>TECNOLOGÍA Y SERVICIOS</p> <p> 911 238 029</p> <p> info@fitshop.es</p> <p> Consulta nuestro horario de apertura en la página web: https://stg.fit/statit5</p>	<p>TECHNISCHE DIENST & SERVICE</p> <p> +31 172 619961</p> <p> service@fitshop.nl</p> <p> De openingstijden vindt u op onze homepage: https://stg.fit/statit3</p>	<p>TECHNICAL SUPPORT & SERVICE</p> <p> +49 4621 4210-944</p> <p> service-int@fitshop.de</p> <p> You can find the opening hours on our homepage: https://stg.fit/statita</p>
PL	AT	CH
<p>DZIAŁ TECHNICZNY I SERWIS</p> <p> 22 307 43 21</p> <p>+49 4621 42 10-948</p> <p> info@fitshop.pl</p> <p> Godziny otwarcia można znaleźć na stronie głównej: https://stg.fit/statit6</p>	<p>TECHNIK & SERVICE</p> <p> 0800 20 20277 (Freecall)</p> <p>+49 4621 42 10-0</p> <p> info@fitshop.at</p> <p> Öffnungszeiten entnehmen Sie unserer Homepage: https://stg.fit/statitb</p>	<p>TECHNIK & SERVICE</p> <p> 0800 202 027</p> <p>+49 4621 42 10-0</p> <p> info@fitshop.ch</p> <p> Öffnungszeiten entnehmen Sie unserer Homepage: https://stg.fit/statit9</p>

Please find a detailed overview including address and opening hours for all stores of the Fitshop Group in Germany and abroad on the following website:

www.fitshop.com/en/stores

WE LIVE FITNESS

WEBSHOP AND SOCIAL MEDIA

Fitshop is Europe's largest specialist store for home fitness equipment with currently over 70 stores and one of the world's most renowned online mail order companies for fitness equipment. Private customers order via the 25 web shops in the respective national language or have their desired equipment assembled on site. In addition, the company supplies fitness studios, hotels, sports clubs, companies and physio practices with professional equipment for endurance and strength training.

Fitshop offers a wide range of fitness equipment from renowned manufacturers, high-quality in-house developments and comprehensive services, such as a build-up service and sports scientific advice before and after the purchase. The company employs numerous sports scientists, fitness trainers and competitive athletes.

Visit us also on our social media platforms or our blog!

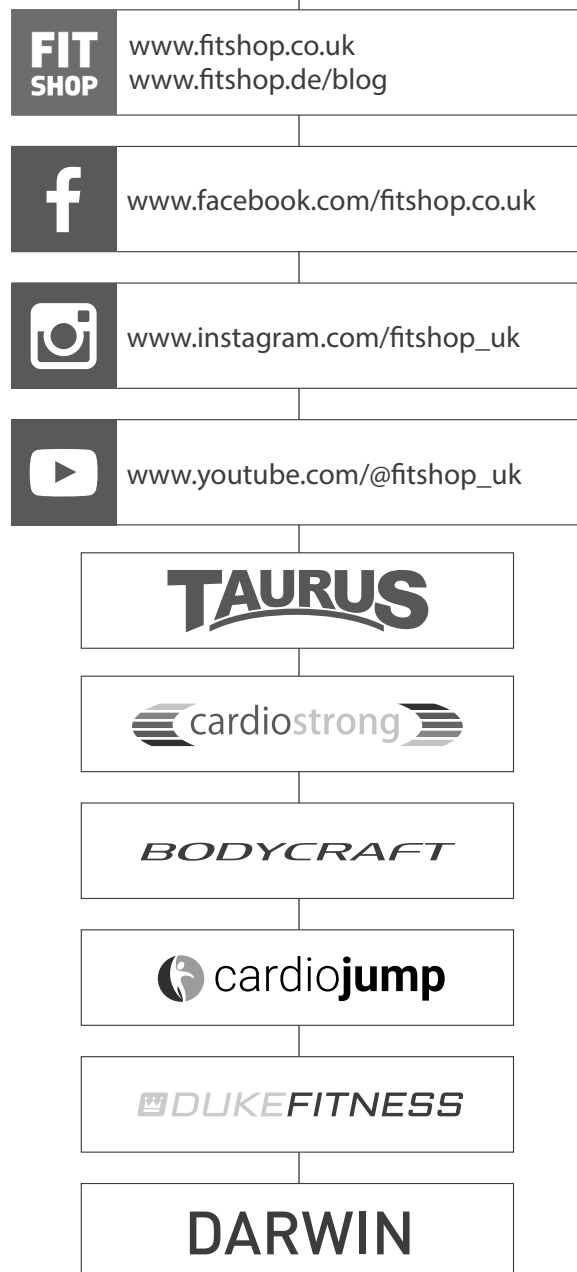

Notes



DARWIN Evo 30