



Assembly and Operating Instructions



max. 120 kg



~ 60 Min.



80 kg

L 175 | W 79 | H 151

DFTM70T01.02

Art. No. DF-TM70-T

DARWIN **TM70** Touch

Content

1	GENERAL INFORMATION	7
1.1	Technical Data	7
1.2	Personal Safety	8
1.3	Electrical Safety	9
1.4	Set-Up Place	10
2	ASSEMBLY	11
2.1	General Instructions	11
2.2	Scope of Delivery	12
2.3	Assembly	14
3	OPERATING INSTRUCTIONS	25
3.1	Console Display	26
3.2	Button Functions	28
3.3	Programmes	30
3.3.1	Quick-Start Programme	30
3.3.2	Target Programmes	31
3.3.3	Loop Programme	33
3.3.4	Heart Rate Controlled Programmes	34
3.3.5	Pre-Set Programmes	35
3.3.6	User defined Programmes	37
3.4	Fitness Test	38
3.5	Body Fat Test (BFI)	40
3.6	Virtual Training	41
3.7	Multimedia	42
4	STORAGE AND TRANSPORT	44
4.1	General Instructions	44
4.2	Transportation Wheels	44
4.3	Folding Mechanism	44
4.3.1	Folding Up the Treadmill	45
4.3.2	Unfolding the Treadmill	45

5	TROUBLESHOOTING, CARE AND MAINTENANCE	46
5.1	General Instructions	46
5.2	Faults and Fault Diagnosis	46
5.3	Care and Maintenance	47
5.3.1	Adjusting the Running Mat	47
5.3.2	Re-tensioning the Running Mat	48
5.3.3	Lubricating the Running Mat	48
5.4	Maintenance and Inspection Calendar	49
6	DISPOSAL	49
7	RECOMMENDED ACCESSORIES	50
8	ORDERING SPARE PARTS	51
8.1	Serial Number and Model Name	51
8.2	Parts List	52
8.3	Exploded Drawing	56
9	WARRANTY	58
10	CONTACT	60

Dear customer,

thank you for choosing Darwin fitness equipment. With Darwin fitness equipment we offer first class home sports equipment at a great price point. Darwin exercise bikes and strength machines are easy to use, have a space-saving design and look really good. With our equipment we want to support you in reaching your athletic goals, no matter if you want to lose weight or train for the national triathlon. If you have any further questions, please contact us, we are looking forward to hearing from you and wish you lots of fun during your training!

Further information can be found at www.sport-tiedje.com.

Intended Use

The equipment may only be used for its intended purpose.

The equipment is only suitable for home use. The equipment is not suitable for semi-professional (e.g. hospitals, associations, hotels, schools, etc.) and commercial or professional use (e.g. fitness studios).

Disclaimer



©2015 Darwin® is a registered brand of the company SportTiedje GmbH. All rights reserved. Any use of this trademark without the explicit written permission of Sport-Tiedje is prohibited.

Product and manual are subject to change. Technical data can be changed without advance notice.

ABOUT THIS MANUAL

Please carefully read the entire manual before installation and first use. The manual will help you to quickly set up the system and explains how to safely use it. Make sure that all persons exercising with the equipment (especially children and persons with physical, sensory, mental or motor disabilities) are informed about this manual and its contents in advance. In case of doubt, responsible persons must supervise the use of the equipment.



Due to ongoing changes and software optimisations, the manual may have to be updated. If you notice any discrepancies during assembly or use, please refer to the manual uploaded to the webshop. The latest manual is always available there.

This equipment has been manufactured according to the latest safety knowledge. As far as possible, potential safety hazards which could cause injury have been eliminated. Make sure to carefully follow the instructions and that all parts are securely in place. If required, read through the instructions again to correct any mistakes.

Please pay close attention to the safety and maintenance instructions given here. The contract partner cannot be held liable for damage to health, accidents or damage to the equipment when it is not used in accordance with these instructions.

The following safety instructions may appear in this manual:

► **ATTENTION**

This notice indicates potentially hazardous situations which, if not avoided, may result in property damage.

⚠ **CAUTION**

This notice indicates potentially hazardous situations which, if not avoided, may result in slight or minor injuries!

⚠ **WARNING**

This notice indicates potentially hazardous situations which, if not avoided, may result in death or serious injuries!

⚠ **DANGER**

This notice indicates potentially hazardous situations which, if not avoided, will result in death or serious injuries!

ⓘ **NOTICE**

This notice indicates further useful information.

Retain these instructions in a safe place for future reference, maintenance or when ordering replacement parts.

1.1 Technical Data

TFT - display of

- + Training time in min
- + Training distance in km
- + Speed in km/h
- + Incline level
- + Calories in kcal

Motor type:	DC-motor (2,25 HP)
Speed:	0.8 km/h–18km/h (0.1 km/h increments)
Incline:	0-15 levels (1 increments)

Programmes in total:	49
Quick-Start programmes:	1
Target programmes:	4
Loop programmes:	1
Pre-set programmes:	36
User defined programmes:	6
HRC programmes:	1

Quickkeys (Speed):	3
Quickkeys (Incline):	3

Running surface (LxB):	140 cm x 46 cm
Running mat thickness:	1.6 mm

Weight and dimensions:

Article weight (gross, incl. packaging):	87 kg
Article weight (net, without packaging):	80 kg

Packing dimensions (LxWxH) approx.:	188 cm x 87 cm x 33.5 cm
Set-up dimensions (LxWxH) approx.:	175 cm x 78.7 cm x 151 cm
Folded dimensions (LxWxH) approx.:	112.2 cm x 80.4 cm x 150 cm

Maximum user weight:	120 kg
----------------------	--------

1.2 Personal Safety

DANGER

- + Before you start using the equipment, you should consult your physician that this type of exercise is suitable for you from a health perspective. Particularly affected are persons who: have a hereditary disposition to high blood pressure or heart disease, are over the age of 45, smoke, have high cholesterol values, are overweight and/or have not exercised regularly in the past year. If you are under medical treatment that affects your heart rate, medical advice is absolutely essential.
- + Note that excessive training can seriously endanger your health. Please also note that heart rate monitoring systems can be inaccurate. If you notice any signs of weakness, nausea, dizziness, pain, shortness of breath, or other abnormal symptoms, stop exercising immediately and seek advice from your doctor if necessary.

WARNING

- + This equipment may not be used by children under the age of 14.
- + Children should not be allowed unsupervised access to the equipment.
- + Persons with disabilities must have a medical license and must be under strict observation when using the equipment.
- + The equipment is strictly for use by one person at a time.
- + If your equipment provides a safety key, the clip of the safety key must be attached to your clothing before starting your training. In the event of a fall, the EMERGENCY STOP of the equipment can be initiated.
- + Keep your hands, feet and other body parts, hair, clothing, jewellery and other objects well clear of moving parts.
- + During use, wear suitable sports clothing rather than loose or baggy clothing. When wearing sports shoes, make sure they have suitable soles, preferably made of rubber or other non-slip materials. Shoes with heels, leather soles, studs or spikes are unsuitable. Never exercise barefoot.

CAUTION

- + If your equipment needs to be connected to the power supply with a mains cable, make sure that the cable is not a potential tripping hazard.
- + Make sure that nobody is within the range of motion of the equipment during training so as not to endanger you or other persons.

ATTENTION

- + Do not insert any objects of any kind into the openings of the device.

1.3 Electrical Safety

DANGER

- + In order to reduce the risk of an electric shock, always unplug the equipment from the mains socket immediately after your workout, before assembly or dismantling, and before maintenance or cleaning. Do not pull on the cable.

WARNING

- + Do not leave the equipment unattended while the mains cable is plugged into the mains socket. During your absence, the mains cable must be removed from the mains socket to prevent improper use by third parties or children.
- + If the mains cable or plug is damaged or defective, contact your contract partner. Until repair, the equipment must not be used.

ATTENTION

- + The equipment requires a mains connection of 220-230 V with 50 Hz mains voltage.
- + The equipment may only be connected directly to an earthed socket using the supplied mains cable. Extension cables must conform to VDE guidelines. Always completely unwind the mains cable.
- + The socket must be protected by a fuse with a minimum fuse rating of "16 A, slow blow".
- + Do not make any changes to the mains cable or the mains plug.
- + Keep the mains cable away from water, heat, oil and sharp edges. Do not route the mains cable underneath the equipment or under a carpet or rug, and do not place any objects on top of it.
- + If your purchased item is equipped with a TFT console, software updates must be carried out regularly. Follow the instructions on the console to perform the update(s).
- + The software systems on gym equipment with TFT consoles are set up only for the pre-installed apps. Do not install any additional apps.

NOTICE

- + The pre-installed apps on TFT consoles are produced and provided by external manufacturers. Sport-Tiedje does not take any responsibility for the availability, functionality or contents of these apps.

1.4 Set-Up Place



WARNING

- + Do not place the equipment in main corridors or escape routes.



CAUTION

- + Make sure that there is a safety area behind the treadmill with a length of at least 2 m and a width at least equal to the width of the treadmill.
- + The training room should be well ventilated during training and not be exposed to any draughts.
- + Choose the place in which to set up the equipment such that there is enough free space/clearance to the front, the rear and to the sides of the equipment.
- + The set-up and mounting surface of the equipment should be flat, loadable and solid.

ATTENTION

- + The device may only be used in one building, in sufficiently tempered and dry rooms (ambient temperatures between 10°C and 35°C). The equipment should not be used outdoors or in rooms with high humidity (over 70%) like swimming pools.
- + A floor protective mat/equipment underlay can help to protect high-quality floor coverings (parquet, laminate, cork, carpets) from dents and sweat and can help to level out slight unevenness.

Recommended free zone:

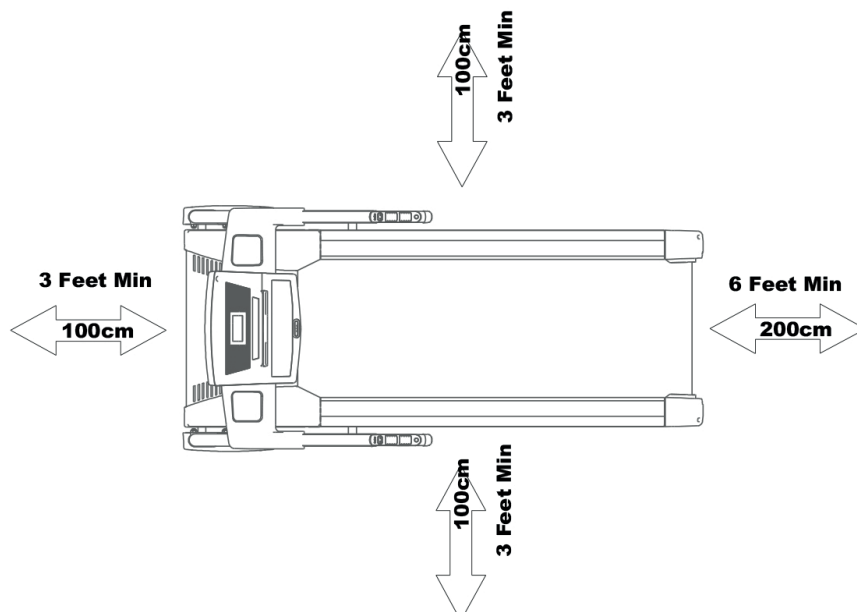

2.1 General Instructions

DANGER

- + Do not leave any tools, packaging materials such as foils or small parts lying around, as otherwise there is a danger of suffocation for children. Keep children away from the equipment during assembly.

WARNING

- + The treadmill is equipped with high-pressure shock absorbers that can cause the treadmill to suddenly open if handled incorrectly. To avoid possible personal injuries, never pull on the areas of the treadmill shown in the illustration. Never try to lift or move the treadmill at the marked areas.
- + Pay attention to the instructions attached to the equipment in order to reduce the risk of injuries.

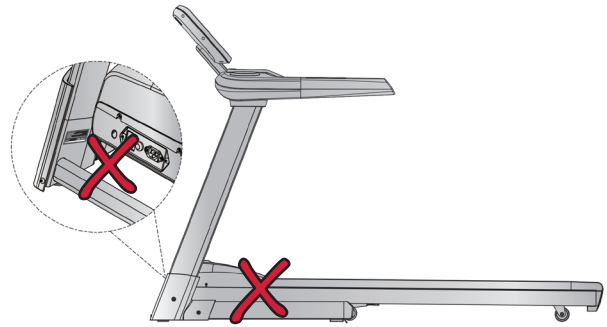

CAUTION

- + Ensure to have sufficient room for movement in each direction during assembly.
- + The assembly of the equipment must be carried out by at least two adults. If in doubt, seek the help of a third technically skilled person.

ATTENTION

- + To prevent damage to the equipment and the floor, assemble the equipment on a mat or packaging board.

NOTICE



- + In order to make the assembly as simple as possible, some screws and nuts to be used can already be pre-assembled.
- + Ideally, assemble the equipment at its later set-up place.

2.2 Scope of Delivery

The scope of delivery consist of the following parts. At the beginning, check whether all parts and tools belonging to the device are included in the scope of delivery and whether damage has occurred. In the event of complaints, the contractual partner must be contacted directly.

⚠ CAUTION

If parts of the scope of delivery are missing or damaged, the assembly must not be carried out.

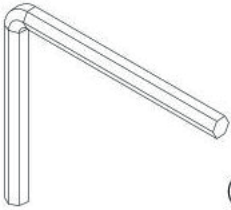
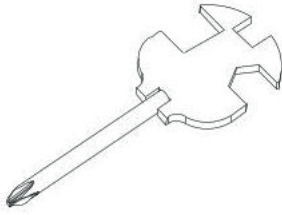
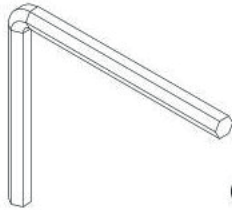
<p>E15 M8*15</p>  <p>(22X)</p>	<p>E24 ST4.2*15</p>  <p>(6X)</p>	<p>E32 ϕ8</p>  <p>(10X)</p>
<p>B07 S5</p>  <p>(1X)</p>	<p>B08 S=13 14 15</p>  <p>(1X)</p>	<p>B11 S6</p>  <p>(1X)</p>

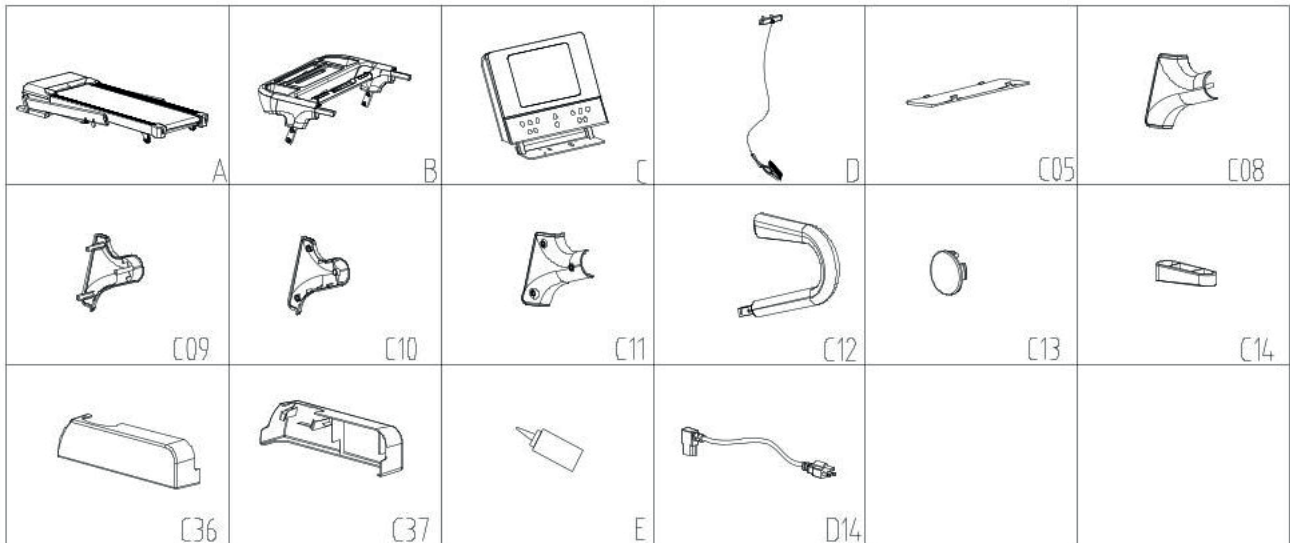

No.	Name	Quantity
A	Main frame assembly	1
B	Instruments assembly	1
C	Panel assembly	1
D	Safety lock assembly	1
C05	Middle and lower covers of instruments	1
C08	Left column outer cover	1
C09	Right column outer cover	1
C10	Left column inner cover	1
C11	Right column inner cover	1
C12	Foam armrest	2
C13	Screw hole plug	4
C14	Armrest tube plug	2
C36	Left bottom shield	1
C37	Right bottom shield	1
E	Oil bottle	1
D14	Standard power cord	1

2.3 Assembly

Before assembly, take a close look at the individual assembly steps shown and carry out the assembly in the order given.

NOTICE

- + First loosely screw all parts together and check that they fit properly. Tighten the screws using the tool only when you are instructed to do so.
- + If you have difficulty recognising the graphics, we recommend that you open and/or download the PDF instructions stored in the webshop on your end device (e.g. smartphone, tablet or PC). There you have the option of zooming in closer. Please note that the Adobe Acrobat Reader programme must be installed on your end device in order to open the file.

Step 1: Unpacking the Treadmill

Remove the packaging and place the treadmill on an even surface.

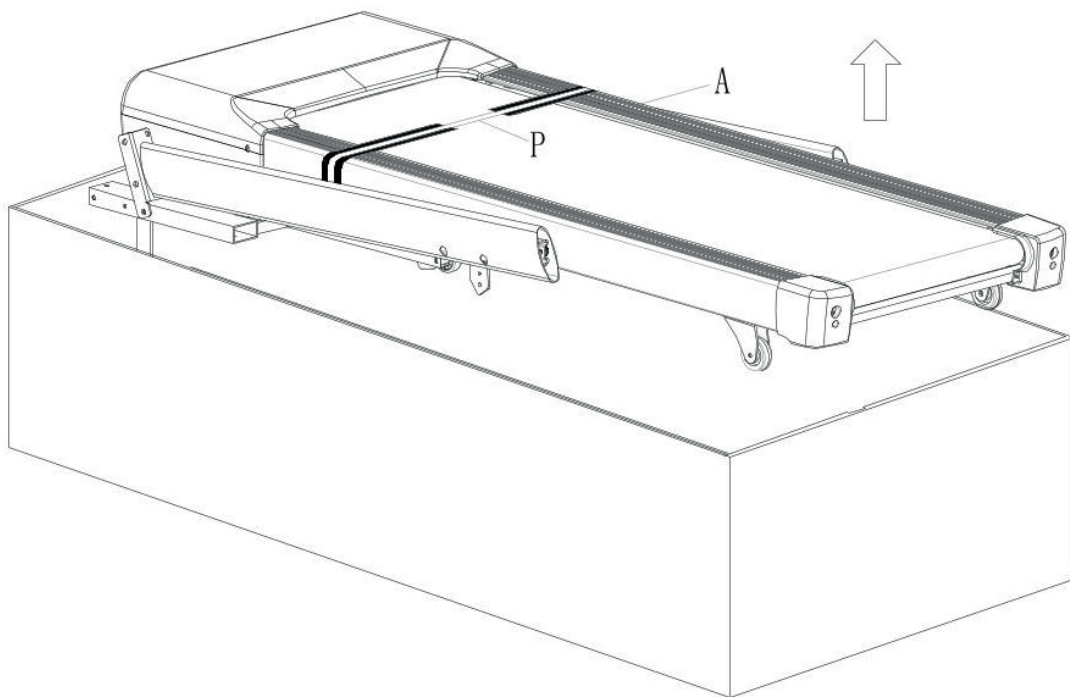

Step 2: Assembly of the Columns

1. Lift up the left column (A03) and fix it with three screws (E15) and three washers (E32).
2. Repeat step 1 with the right column (A04).

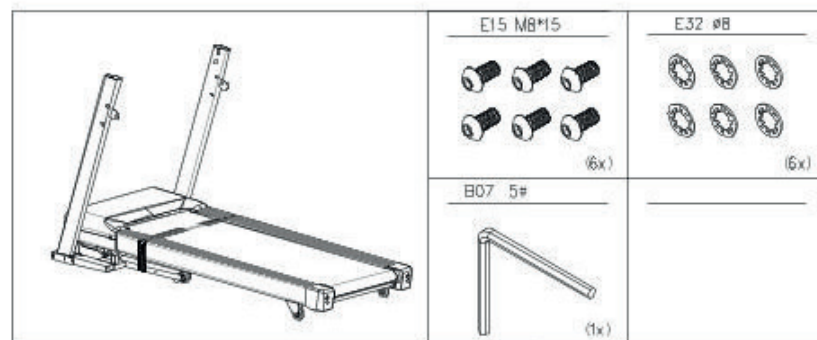
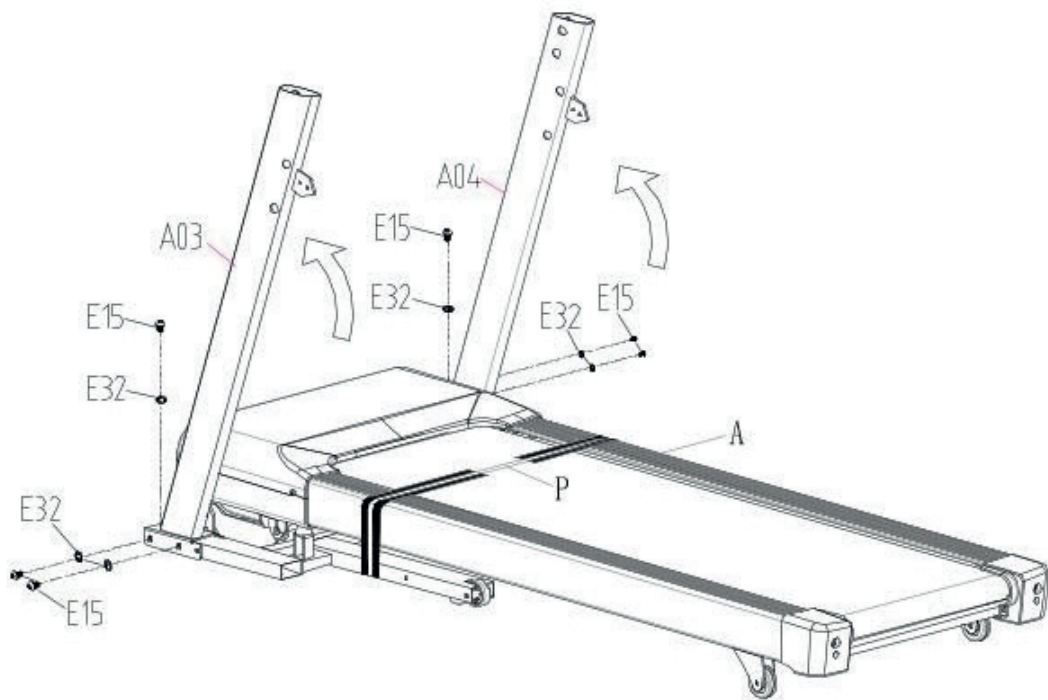

Step 3: Assembly of the Instrument

1. Connect the cables D09 and D10 with one another.

► **ATTENTION**

Make sure not to pinch the cables during the following steps.

2. Slide the instruments assembly (B) onto the columns (A03 & A04).
3. Mount the instruments assembly (B) onto the columns (A03 & A04) with two screws each (E15).
4. Place one screw hole plug (C13) on each of the screws (E15).

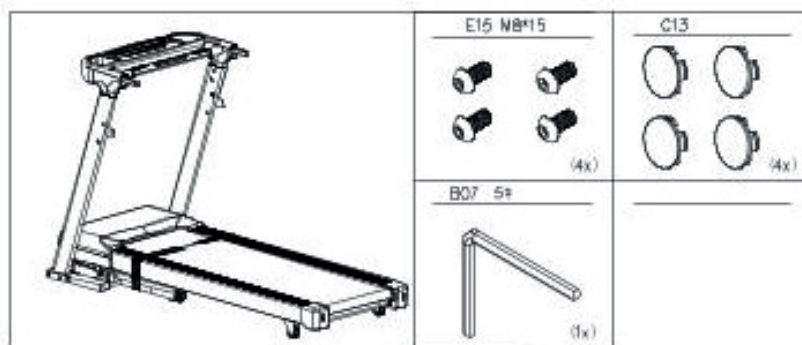
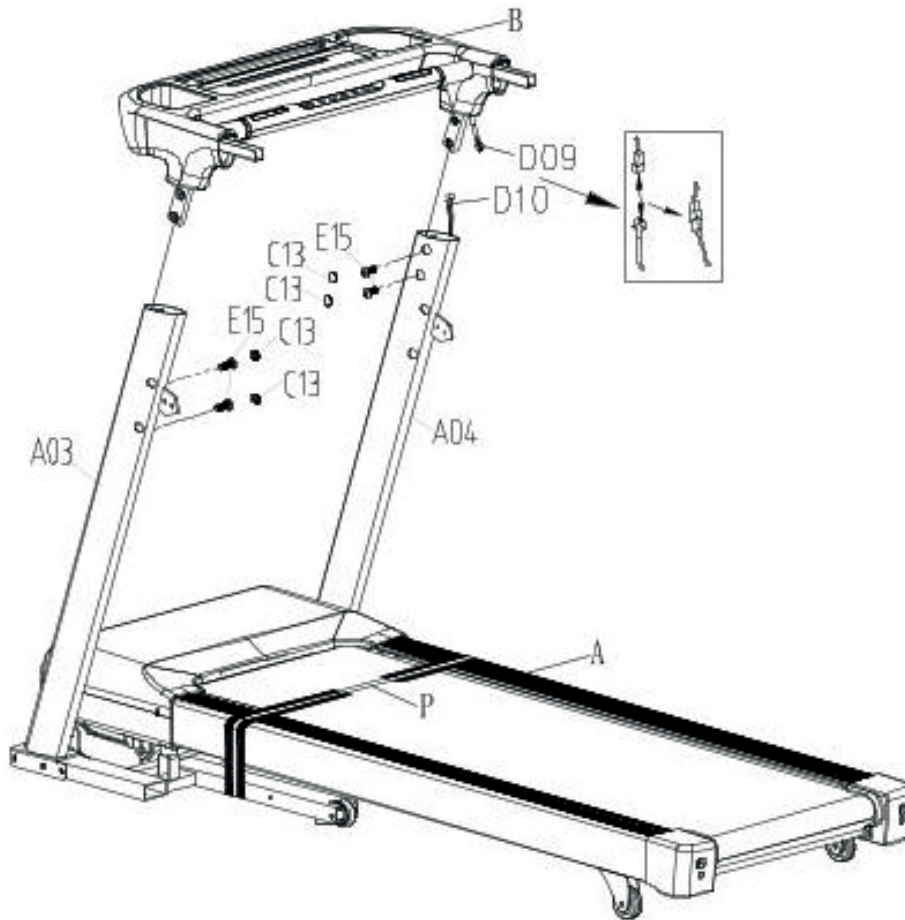

Step 4: Assembly of the Panel part 1

Connect the cables of the instruments assembly (B) with its respective counterparts on the panel assembly (C).

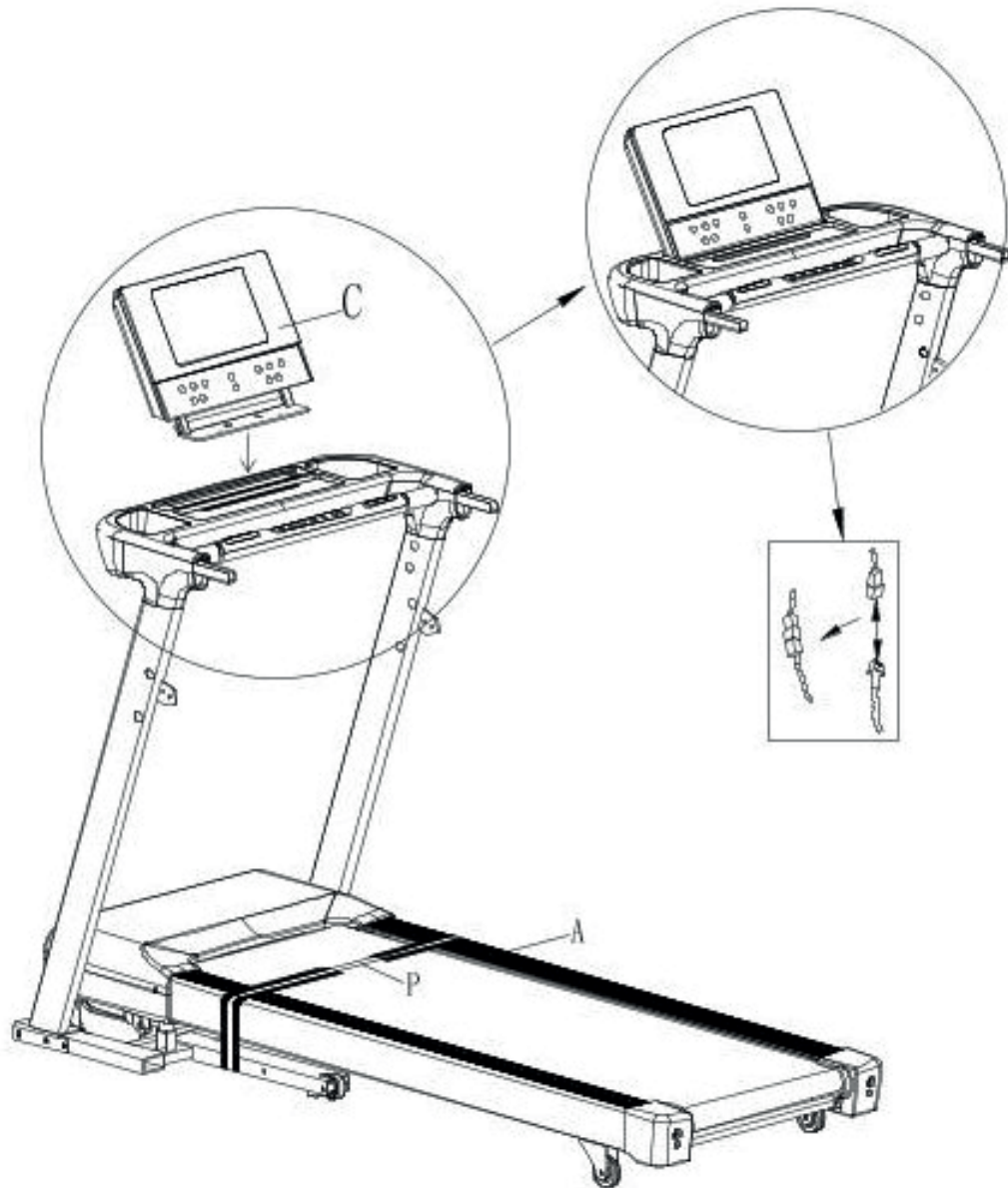

Step 5: Assembly of the Panel part 2

► ATTENTION

Make sure not to pinch the cables during the following steps.

1. Slide the panel assembly (C) onto the instruments assembly (B).
2. Fix the panel assembly (C) onto the instruments assembly (B) with four screws (E15) and four washers (E32).
3. Place the middle and lower cover of instruments (C05) over the screws (E15).

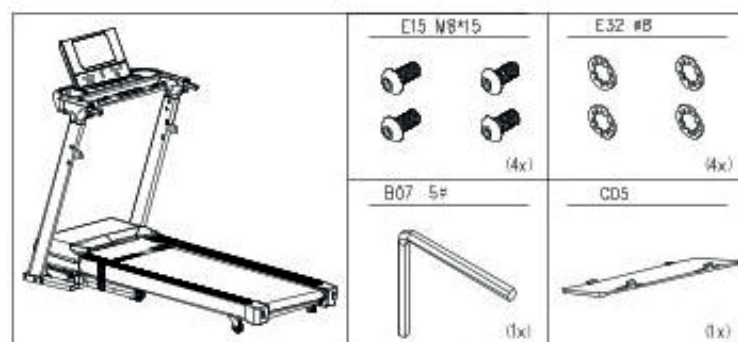

Step 6: Assembly of the Foam Armrests part 1

1. Place the foam armrests (C12) on the instruments assembly (B).
2. Fix the upper part of the foam armrests (C12) on the instruments assembly (B) with three screws each (E15).
3. Fix the lower part of the foam armrests (C12) on the columns (A03 & A04) with one screw each (E15).
4. Place one armrest tube plug (C14) on each of the upper screw joints of the foam armrests (C12).

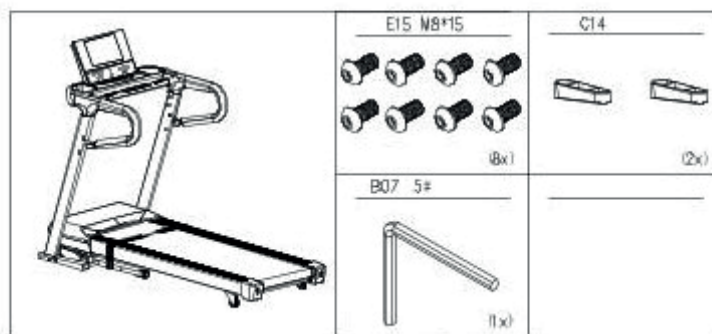
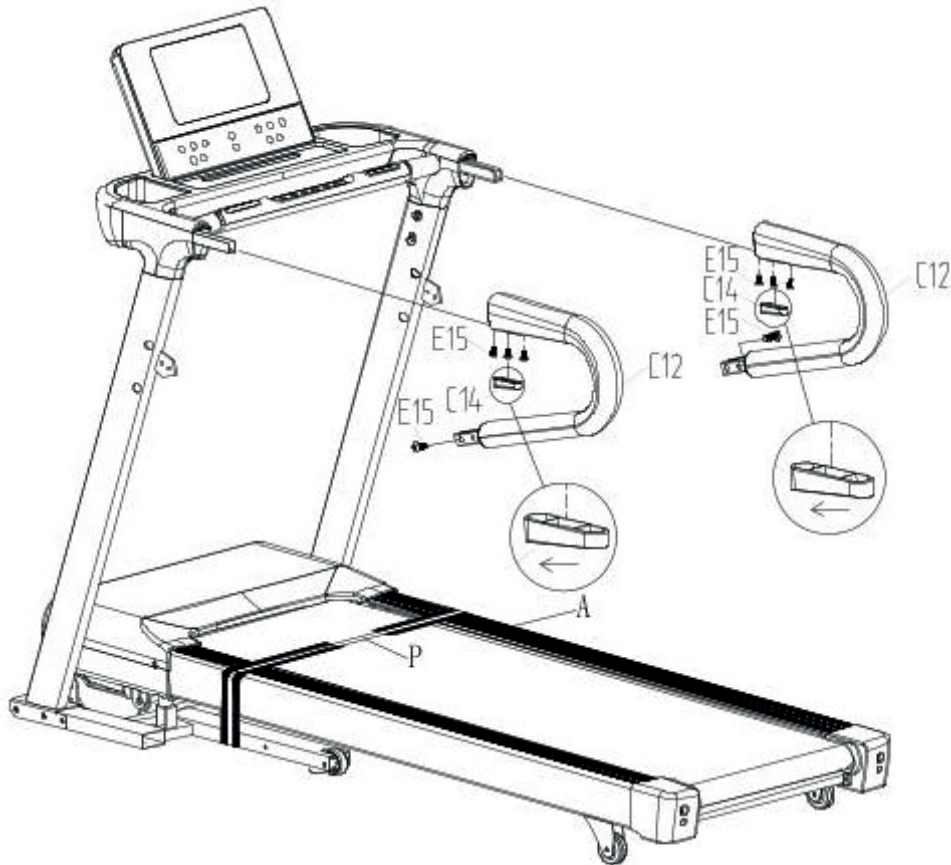

Step 7: Assembly of the Foam Armrests part 2

① NOTICE

The followings steps must be conducted simultaneously.

1. Place the right column outer cover (C09) on the outside and simultaneously the right column inner cover (C11) on the inside of the right foam armrest (C12).
2. Fix the two right covers (C09 & C11) with one another with three screws (E24).
3. Place the left column outer cover (C08) on the outside and simultaneously the left column inner cover (C10) on the inside of the left foam armrest (C12).
4. Fix the two left covers (C08 & C10) with one another with three screws (E24).

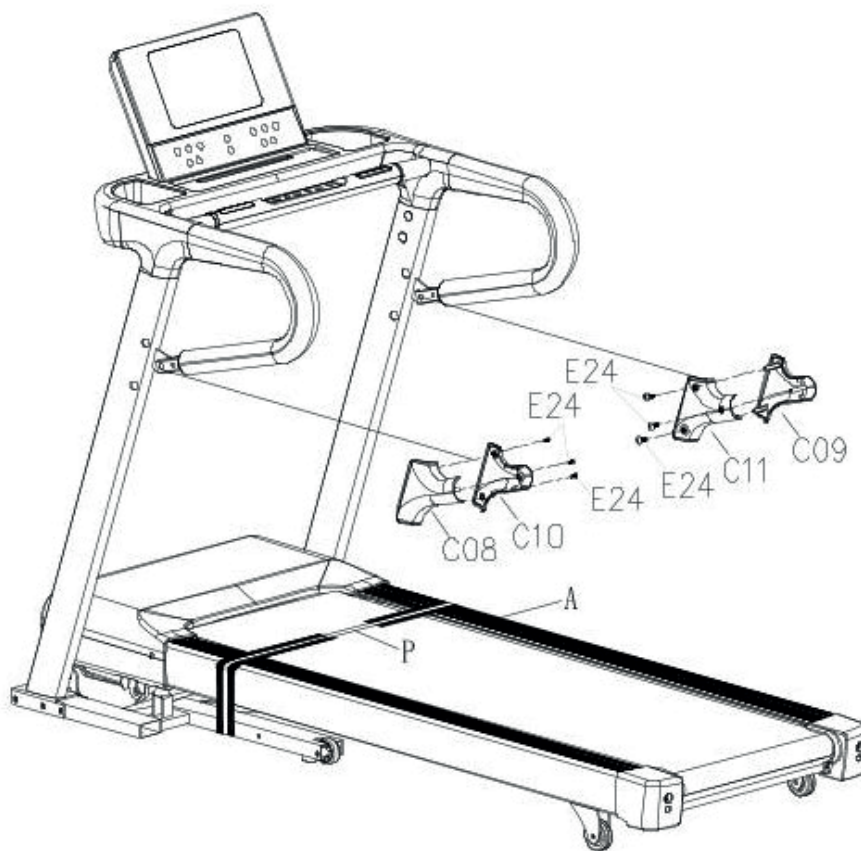

	E24 ST4-2*15	
	 (6x)	
	B08 S=13 14 15	
	 (1x)	

Step 8: Assembly of the Bottom Shields

1. Tuck the right bottom shield (C37) on the right side of the main frame (A).
2. Tuck the left bottom shield (C36) on the left side of the main frame (A).

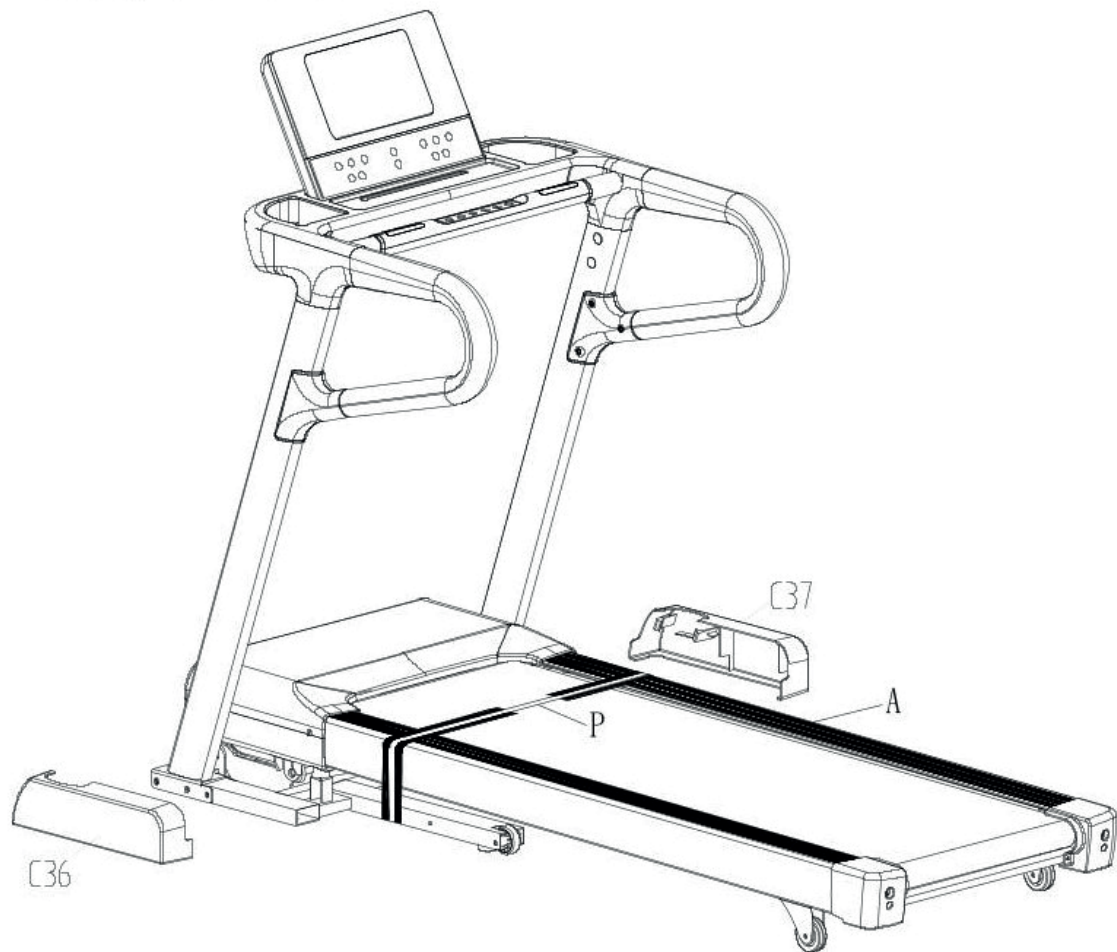

Step 9: Removal of the Cable Tie

Remove the cable tie (P) with a pair of scissors before using the treadmill.



Step 10: Removal of the Safety Pin

Release the safety pin (G) by removing the screws (E15) and the washers (C33).

ⓘ NOTICE

Keep the safety pins for future transport. The safety pins must be re-attached for transport.



Step 11: Alignment of the Feet

If the floor is uneven, you can stabilize the treadmill by turning the two setting screws under the main frame.

⚠ WARNING

The treadmill is equipped with high-pressure shock absorbers that can cause the treadmill to suddenly open if handled incorrectly. For more information, refer to the section 2.1 of this manual.

1. Lift the treadmill on the desired side and rotate the setting screws under the main frame.
2. Rotate the screws (C30) clockwise in order to remove them and to raise the running surface.
3. Rotate them counterclockwise in order to lower the running surface.

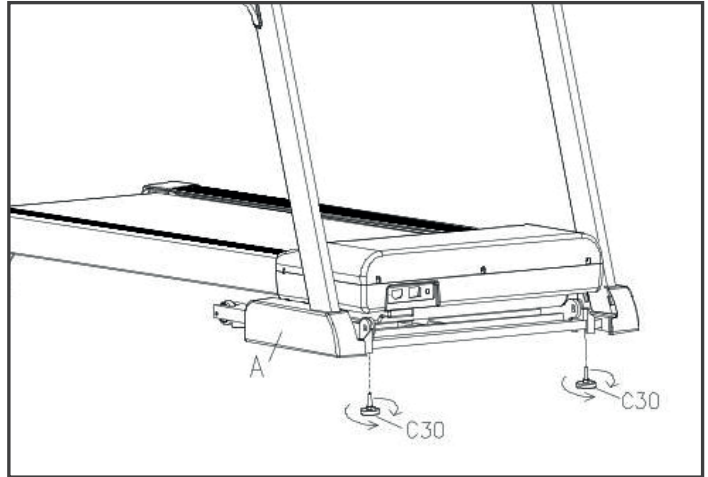

Step 12: Connecting the Equipment to the Mains Supply

▶ ATTENTION

The equipment must not be connected to a multiple socket, otherwise it cannot be guaranteed that the equipment will be supplied with sufficient power. Technical errors can result.

Plug the power plug into a wall outlet that complies with the instructions in the chapter on electrical safety.



NOTICE

Familiarise yourself with all the functions and setting options of the device before starting training. Have the proper use of this product explained to you by a specialist.

SAFETY KEY**WARNING**

- + For your safety, the device is equipped with an EMERGENCY STOP function. The equipment can only be operated if the safety key is correctly attached to the contact point of the cockpit. If the safety key is no longer on the contact point, the equipment automatically stops. Therefore, the Safety Key cord with the clip must be attached to your clothing before every training session. If you want to quickly stop the treadmill, if you can no longer control the speed, or if another emergency occurs, remove the safety key from the cockpit using the cord.
- + To enable the safety key to detach from the contact point of the cockpit in the event of a fall, the safety key clip must be firmly attached to your clothing!
- + Make sure that the safety key is not accessible to children.



3.1 Console Display

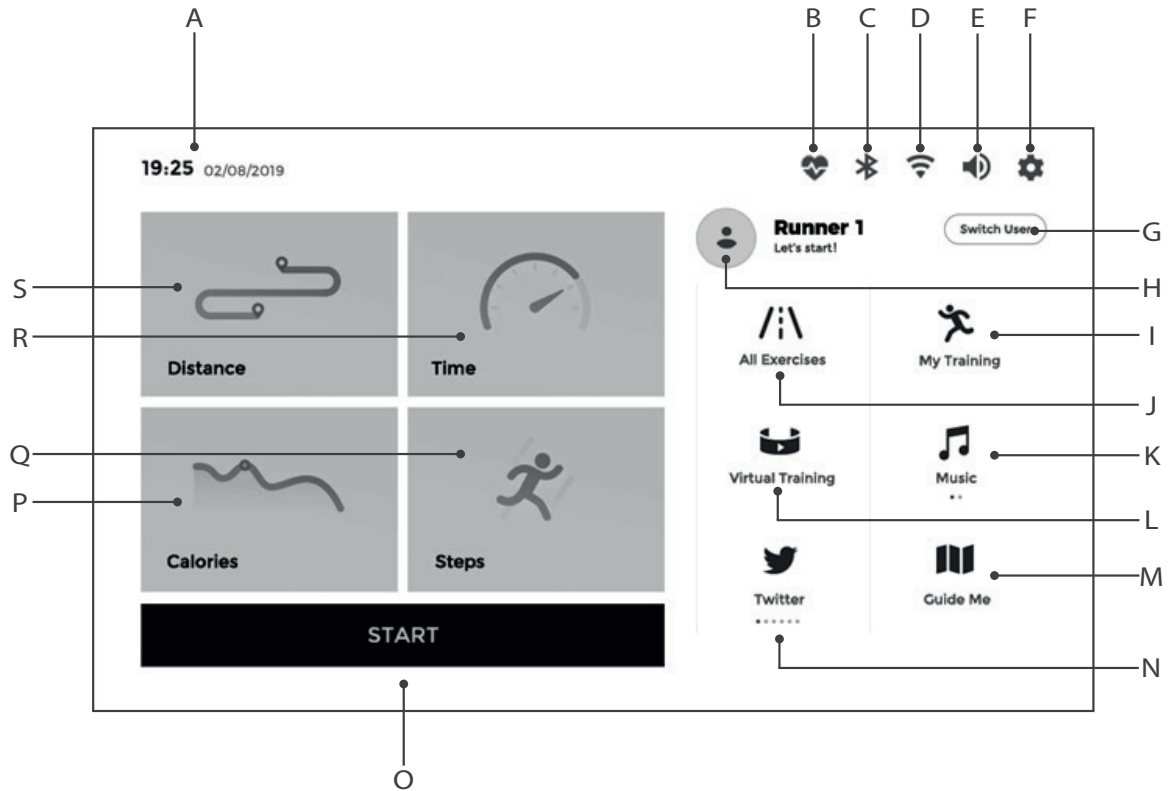

Icons	Functions
A Date & Time	+ The date and time will automatically be calibrated once the treadmill is connected to the wi-fi.
B Pulse	+ This icon lights up when the treadmill registers a pulse. If you use a compatible chest strap, your current pulse will be displayed here.
C Bluetooth	+ This icon lights up when the treadmill is connected to an app.
D Wi-Fi	+ This icon lights up when the treadmill is connected to the wi-fi.
E Volume	+ You can adjust the volume here.
F Settings	+ You can check and adjust the settings here.
G Switch User	+ Use this function to quickly switch between users.
H Runner 1	+ Shows the current user.

I	MyTraining	+ Here you have access to your user profile and your training data. You can also access the user programmes, the fitness tests and the body fat test via this button.
J	All Exercises	+ This button takes you to the heart rate programmes, the loop programme and the preset programmes.
K	Music	+ Tap here to play music or videos.
L	Virtual Training	+ Tap here to go to the virtual trainings.
M	Guide Me	+ Here you will find the user manual
N	Twitter	+ Here you will find more apps such as Twitter, Youtube etc.
O	Start	+ Use this button to start a training.
P	Calories	+ Tap here to go to the Calories target programme.
Q	Steps	+ Tap here to go to the Steps target programme.
R	Time	+ Tap here to go to the Time target programme.
S	Distance	+ Tap here to go to the Distance target programme.

3.2 Button Functions

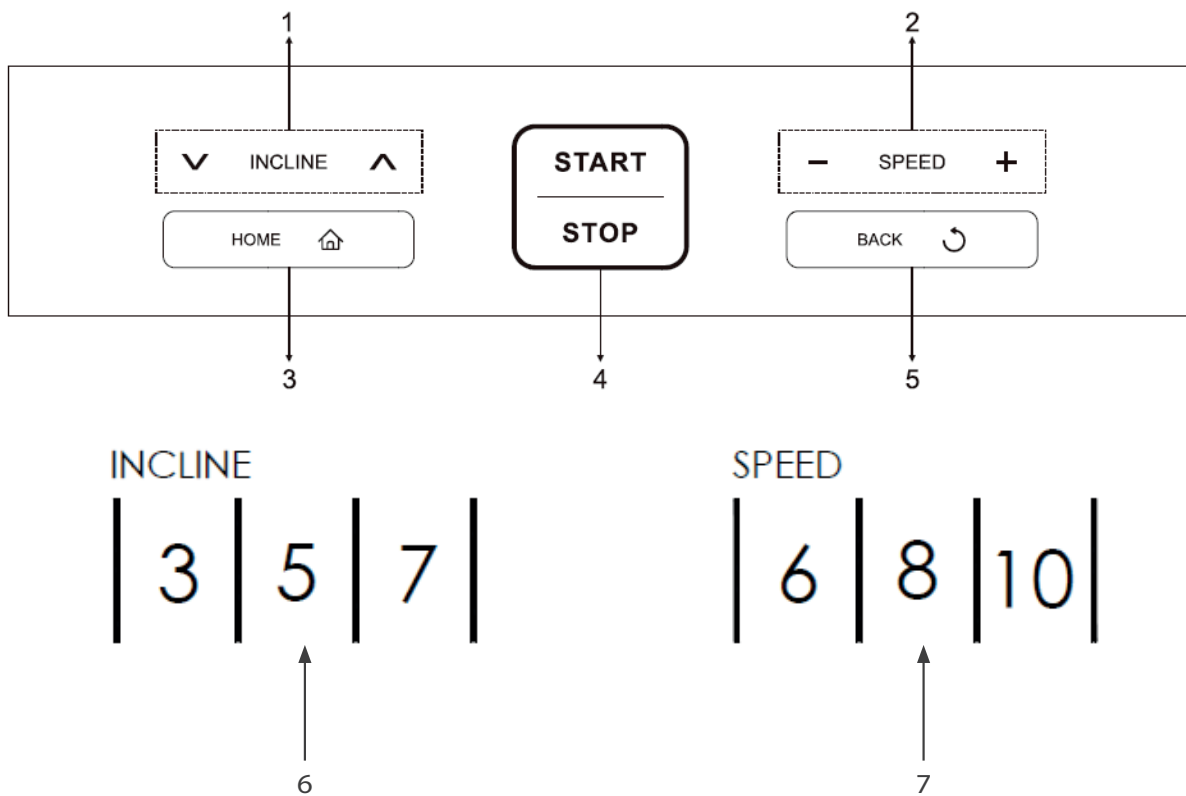

Buttons		Functions
1	INCLINE	+ With these buttons you can adjust the incline. + Setting range: 0 - 15 levels
2	SPEED	+ With these buttons you can adjust the speed. + Setting range: 0.8 - 18 km/h
3	HOME	+ With this button you can return to the main menu.
4	START/STOP	+ With this button you can start and stop your training.
5	BACK	+ With this button you can return to the previous page.

6	INCLINE Quickkeys	+ With these three quickkeys (3/5/7) you can adjust the incline of the treadmill. For example, if you press 7, the treadmill will automatically adjust the incline to level 7.
7	SPEED Quickkeys	+ With these three quickkeys (6/8/10) you can adjust the speed of the treadmill. For example, if you press 10, the treadmill will automatically adjust the speed to 10 km/h.

3.3 Programmes

This treadmill offers a great variety of programmes. These include:

+ Quick-Start programme:	1
+ Target programmes:	4
+ HRC programme:	1
+ Pre-set programmes:	36
+ User programmes:	6
+ Fitness test	1
+ Body fat test	1

The console also includes several virtual trainings with different sceneries. Furthermore, you can access third party apps and play your own music and videos.

3.3.1 Quick-Start Programme

There is one quick-start programme.

1. To directly start the training, press the START/STOP button.

The training starts.

The treadmill starts at the lowest speed (0.8 km/h) and incline level (0).

All values will start counting upwards.

2. To adjust the speed, press the SPEED + / - buttons.
3. To adjust the incline, press the INCLINE \wedge \vee buttons.

NOTICE

Alternatively, you can adjust the speed and incline level by using the respective quickkeys on the console.

4. To end the training, press the START/STOP button.

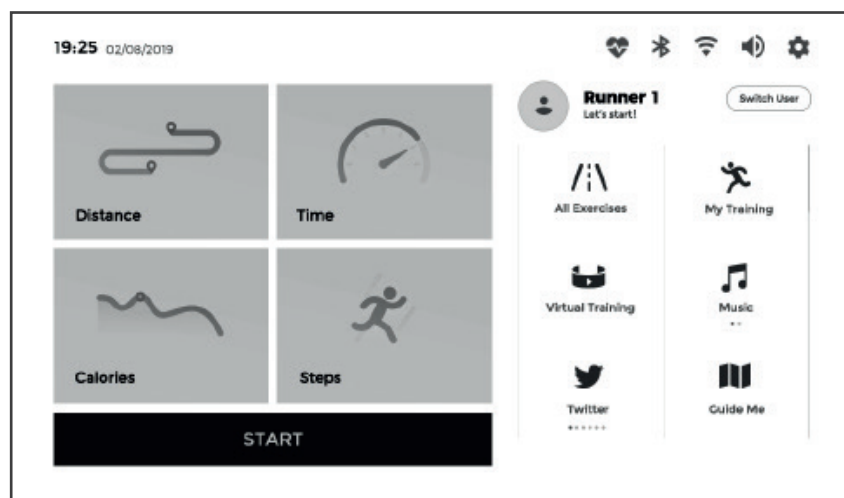

3.3.2 Target Programmes

There are a total of four target programmes to choose from: Distance, Time, Calories and Steps.

Distance

1. To select the distance mode, tap on the respective icon in the main menu.
2. Select between 5 km, 10 km, 15 km, half marathon, marathon or Customize for a user defined value.
3. To start the training, tap on START.

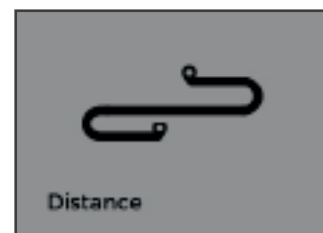

The training starts.

A countdown will start for the set km value, whilst all other values will be counted upwards.

4. To adjust the speed, tap on SPEED + / -.
5. To adjust the incline, tap on INCLINE \wedge \vee .
6. To pause the training, tap on PAUSE.
7. To end the training, tap on STOP.

→ *The console displays a summary of the training data.*

Time

1. To select the time mode, tap on the respective icon in the main menu.
2. Select between 10 Min, 20 Min, 30 Min, 40 Min, 60 Min or Customize for a user defined value.
3. To start the training, tap on START.



The training starts.

A countdown will start for the set time value, whilst all other values will be counted upwards.

4. To adjust the speed, tap on SPEED + / -.
5. To adjust the incline, tap on INCLINE \wedge \vee .
6. To pause the training, tap on PAUSE.
7. To end the training, tap on STOP.

→ *The console displays a summary of the training data.*

Calories

1. To select the calories mode, tap on the respective icon in the main menu.
2. Select between 150 kcal, 300 kcal, 500 kcal, 800 kcal, 1000 kcal or Customize for a user defined value.
3. To start the training, tap on START.



The training starts.

A countdown will start for the set calorie value, whilst all other values will be counted upwards.

4. To adjust the speed, tap on SPEED + / -.
5. To adjust the incline, tap on INCLINE \wedge \vee .
6. To pause the training, tap on PAUSE.
7. To end the training, tap on STOP.

→ *The console displays a summary of the training data.*

Steps

1. To select the steps mode, tap on the respective icon in the main menu.
2. Select between 1 kilosteps, 2 kilosteps, 5 kilosteps, 8 kilosteps, 10 kilosteps or Customize for a user defined value.
3. To start the training, tap on START.

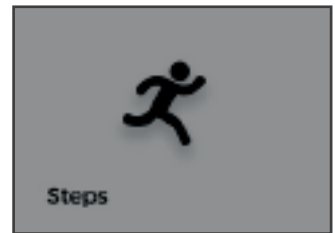

The training starts.

A countdown will start for the set kilosteps value, whilst all other values will be counted upwards.

4. To adjust the speed, tap on SPEED + / -.
5. To adjust the incline, tap on INCLINE \wedge \vee .
6. To pause the training, tap on PAUSE.
7. To end the training, tap on STOP.

→ *The console displays a summary of the training data.*

3.3.3 Loop Programme

There is one loop programme.

1. To select the loop programme, tap on 'Runway' in the menu.

You will be forwarded to the settings.

2. Set the desired amount of loops.

NOTICE

One loop is 400 m. Only completed loops will be counted. If you stop your training during a loop, the loop will not be included in your final results.

3. To start the training, tap on START.

The training starts.

All values will be counted upwards.

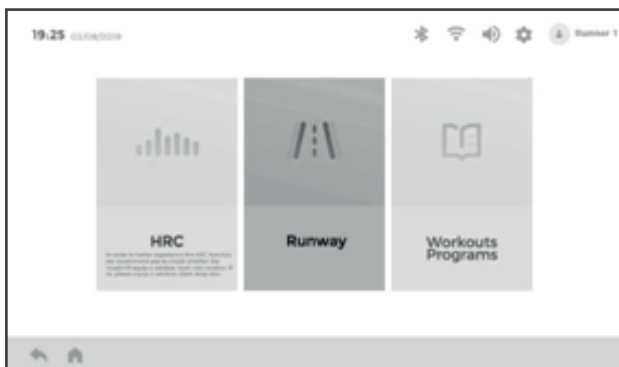

4. To adjust the speed, tap on SPEED + / -.
5. To adjust the incline, tap on INCLINE ^ / v.
6. To pause the training, tap on PAUSE.
7. To end the training, tap on STOP.

→ *The console displays a summary of the training data.*



3.3.4 Heart Rate Controlled Programmes

WARNING

Your training equipment is not a medical device. The heart rate measurement of this equipment may be inaccurate. Various factors can affect the accuracy of the heart rate measurement. The heart rate measurement serves only as a training aid.

There is one heart rate controlled programme.

1. To select the heart rate controlled programme, slightly tap on 'HRC' in the menu.

You will be forwarded to the HRC settings.

2. Set your desired values for target heart rate, training time, maximum speed and intensity by swiping on the respective setting bars.

NOTICE

The age value can not be set here and must be set in the user settings.

3. To start the training, tap on START.

The training starts.

All values will be counted upwards.

The pink line shows the maximum heart rate, the blue line shows the target heart rate and the red line shows your current heart rate.

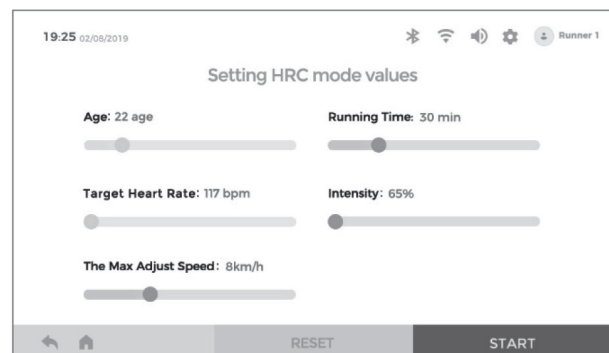
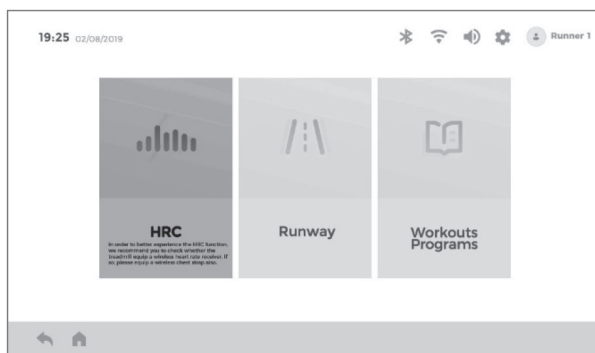

4. To adjust the speed, tap on SPEED + / -.
5. To adjust the incline, tap on INCLINE \wedge \vee .
6. To pause the training, tap on PAUSE.
7. To end the training, tap on STOP.

→ *The console displays a summary of the training data.*

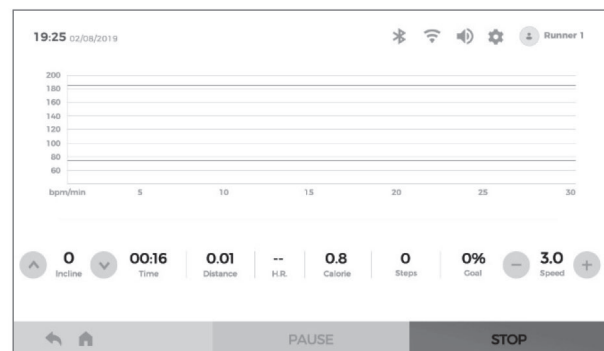

3.3.5 Pre-Set Programmes

There is a total of 36 pre-set programmes (P1 - P36) to choose from.

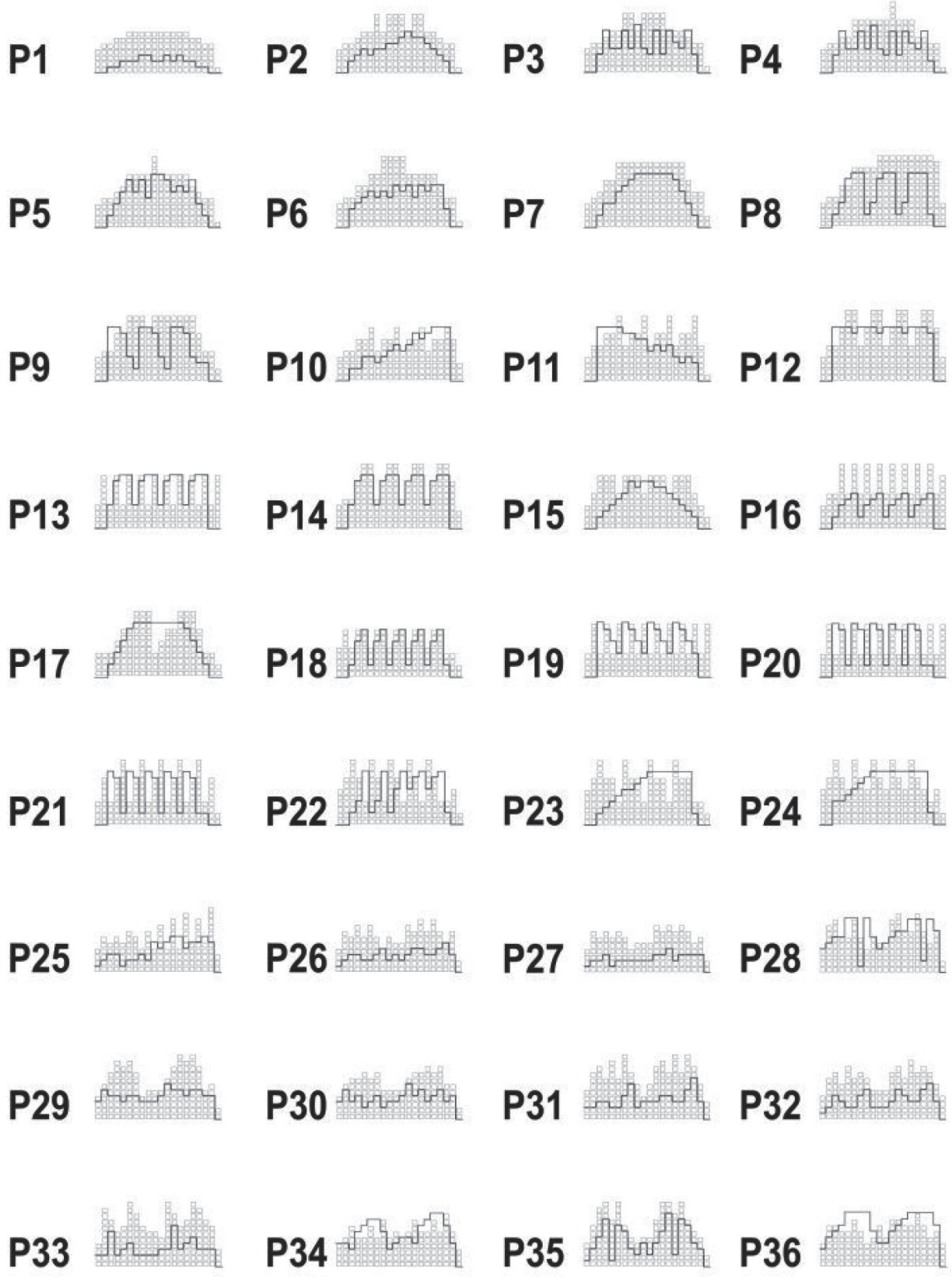

1. To select one of the pre-set programmes, tap on 'Workout Programs' in the menu.
2. Select the desired programme by tipping on one of the programmes P1-P14 in the upper part of the display.

The chosen programme will be marked in bold and the respective profile with the set speed and incline will be shown in the graphic.

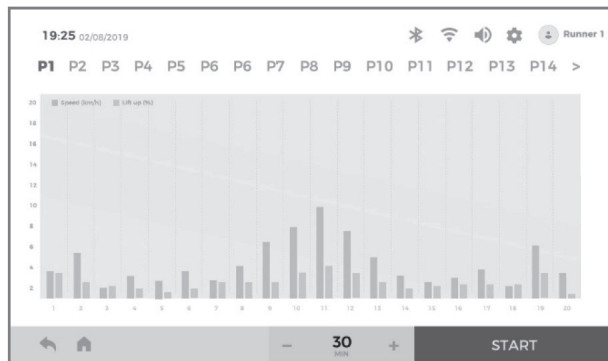
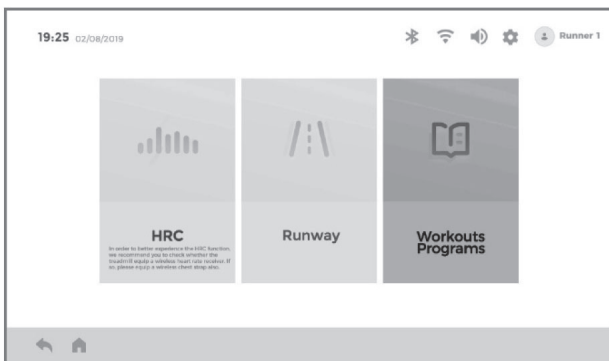

NOTICE

Swipe left and right in the programme bar to enter the other pre-set programmes.

3. Set the desired training time.
4. To start the training, tap on START.

The training starts.

All values will be counted upwards.

You can adjust the speed and incline during the training. An adjustment will only be adapted for the specific segment.

5. To pause the training, tap on PAUSE.
6. To end the training, tap on STOP.

→ *The console displays a summary of the training data.*

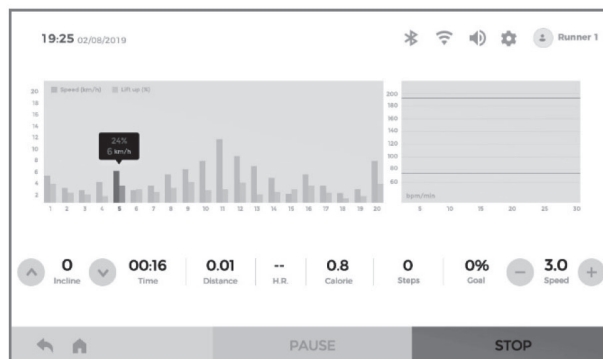

3.3.6 User defined Programmes

For each user there are six user defined programmes.

With a user defined programme, you can design your own training by setting the speed and incline level for a total of 20 segments per training.

1. To select one of the user defined programmes, tap on 'My Programs' in the menu.

The current user will be displayed as U1-U6 in the upper bar of the display.

2. Set a value for speed and incline for each of the 20 segments.

NOTICE

You can switch between speed and incline by tapping on the respective icon in the upper part of the display.

3. Set the desired training time.
4. To start the training, tap on START.

The training starts.

The treadmill starts with the set speed and incline level of the first segment.

All values will be counted upwards.

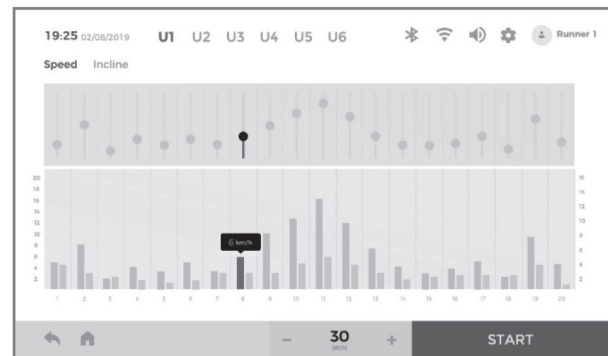
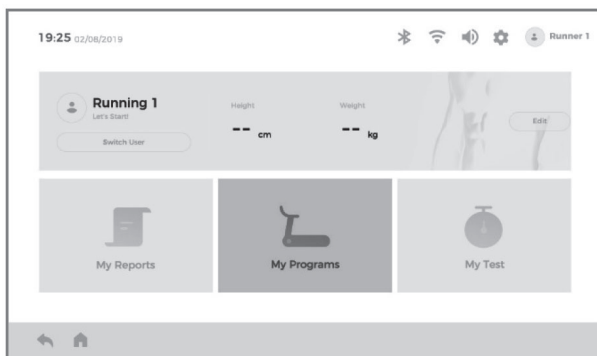

NOTICE

You can adjust the speed and incline during the training. An adjusted value will only be adapted in the specific segment.

5. To pause the training, tap on PAUSE.
6. To end the training, tap on STOP.

→ *The console displays a summary of the training data.*

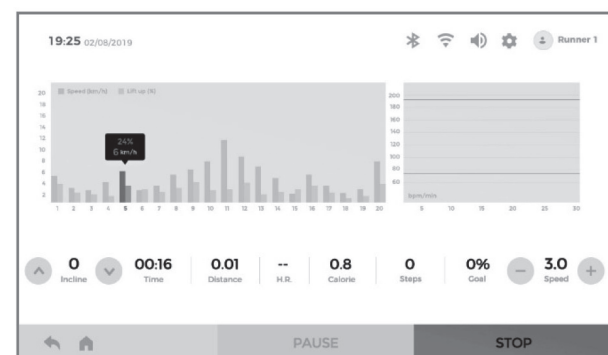

3.4 Fitness Test

There are two different fitness tests to choose from. Both tests have a duration of 15 minutes. While the 'HRC' fitness test determines your physical fitness in accordance to your age and heart rate, the 'PRO' fitness test does not use heart rate for the calculation.

1. To select the fitness tests, tap on 'My Test' in the menu.
2. Tap on 'Fitness Test'.
3. Select between 'HRC' and 'PRO'.

NOTICE

For the HRC test, use a compatible chest strap and receiver for the best possible results.

NOTICE

The following setting can not be set for the 'PRO' fitness test.

4. For the HRC test, set the desired target heart rate and the maximum speed.
5. To start the test, tap on START.

The test starts.



All values will be counted upwards.

6. To adjust the speed, tap on SPEED + / -.
7. To adjust the incline, tap on INCLINE ^ ∨.

→ *The test will automatically end after 15 minutes.*

8. To end the test early, tap on STOP.

NOTICE

If you end the test before the 15 minutes have passed, no results will be determined.

Age		V02MAX (ml/min/kg)				
Male	20-29	V<38	38≤V<42	42≤V<46	46≤V<51	V≥51
	30-39	V<37	37≤V<41	41≤V<44	44≤V<48	V≥48
	40-49	V<35	35≤V<38	38≤V<42	42≤V<46	V≥46
	50-59	V<32	32≤V<36	32≤V<39	39≤V<43	V≥43
	60-69	V<29	29≤V<32	32≤V<36	36≤V<40	V≥40
	70-79	V<26	26≤V<29	29≤V<32	32≤V<37	V≥37
Female	20-29	V<32	32≤V<36	36≤V<40	40≤V<44	V≥44
	30-39	V<31	31≤V<34	34≤V<38	38≤V<42	V≥42
	40-49	V<29	29≤V<33	33≤V<36	36≤V<40	V≥40
	50-59	V<27	27≤V<30	30≤V<33	33≤V<37	V≥37
	60-69	V<25	25≤V<27	27≤V<30	30≤V<33	V≥33
	70-79	V<24	24≤V<26	26≤V<28	28≤V<31	V≥31
Class		Fail	Pass	Good	Great	Excellent
Result		E	D	C	B	A

3.5 Body Fat Test (BFI)

There is one body fat test. This test calculates your body fat percentage within 8 seconds.

1. Tap on 'Body Fat' in the menu.
2. Set your personal data such as sex, birth date, height and weight.
3. Place both of your hands firmly on the hand pulse sensors.

Your body fat percentage will be calculated within 8 seconds.

→ *The result will be displayed on the screen.*

NOTICE

Based on the following table, you can see which body fat percentage results in the different results.

BFI in %	Results
<19	THIN
(20-25)	NORMAL
(26-29)	WEIGHT (slight overweight)
>30	FAT (overweight)

3.6 Virtual Training

There is a variety of different virtual trainings to choose from. With the videos, the console simulates different sceneries in which you can train virtually.

1. To select the virtual trainings, tap on 'Virtual Training' in the menu.
2. Select the desired video by swiping left and right.
3. To start the training, tap on START.

The training starts.

All values will be counted upwards.

4. To adjust the speed, tap on SPEED + / -.
5. To adjust the incline, tap on INCLINE ^ ∨.

ⓘ NOTICE

The training data can be shown or hidden. For this, tap on the arrow in the lower left corner of the screen.

6. To pause the training, tap on PAUSE.
7. To end the training, tap on STOP.

→ *The console displays a summary of the training data.*



3.7 Multimedia

The multimedia function allows you to access different third party apps. Also, you can play your own music and video files. The apps include:

- + Youtube
- + Facebook
- + Google Chrome
- + Twitter
- + Instagram
- + Netflix
- + Spotify
- + Amazon Music
- + Amazon Video

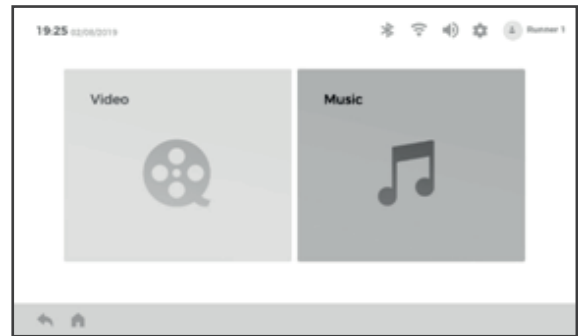

Formats: .mp3, .ape, .mp4, .mov (or other common video and music formats)

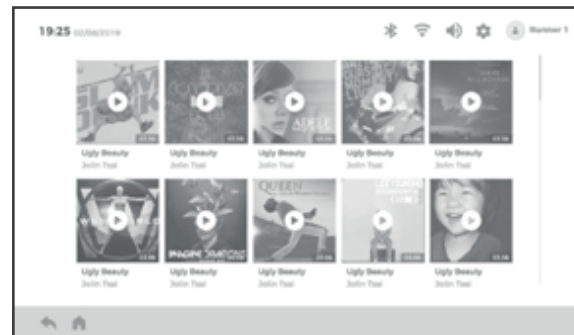
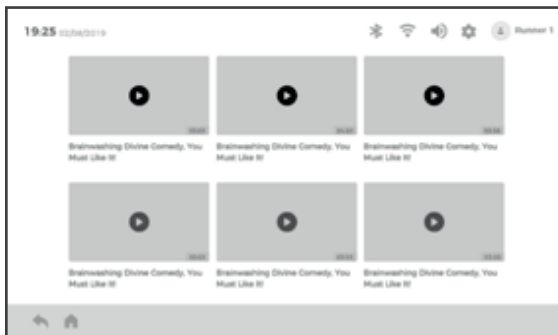

NOTICE

In order to play your own music and videos, you need a USB-stick with the respective files. Insert the USB-stick into the USB-slot of the console.

1. Select between video and music.
2. Select the desired music or video file.
3. To start the training, tap on START.



The training starts.

All values will be counted upwards.

4. To adjust the speed, tap on SPEED + / -.
5. To adjust the incline, tap on INCLINE ^ ∨.

NOTICE

The training data can be shown or hidden. For this, tap on the arrow in the lower left corner of the screen.

NOTICE

The video or music tab can be minimized or maximized.

6. To pause the training, tap on PAUSE.
7. To end the training, tap on STOP.

→ *The console displays a summary of the training data.*



4.1 General Instructions

⚠ WARNING

- + The storage location should be chosen so that improper use by third parties or children can be prevented.
- + If your equipment does not have transportation wheels, the equipment must be disassembled before transportation.

▶ ATTENTION

- + Make sure that the equipment is protected from moisture, dust and dirt in the selected storage location. The storage location should be dry and well ventilated and have a constant ambient temperature between 10°C and 35°C.

4.2 Transportation Wheels

▶ ATTENTION

If you want to transport your equipment over particularly sensitive and soft floor coverings, such as parquet, planks or laminate, lay out the transport route with cardboard or similar to avoid possible floor damage.

1. Stand behind the equipment and lift it until the weight is transferred to the transportation wheels. After that, you easily can move the equipment to a new position. For long transport distances the equipment should be disassembled and safely packed.
2. Select the new location by following the instructions in the section 1.4 of this manual.

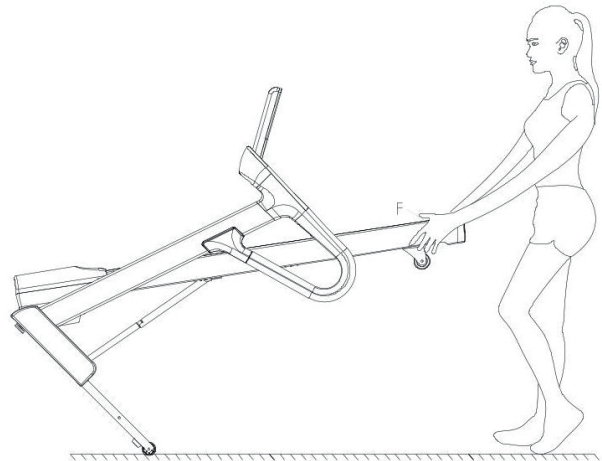

4.3 Folding Mechanism

⚠ WARNING

- + The treadmill is equipped with high-pressure shock absorbers that can cause the treadmill to suddenly open if handled incorrectly. For more information, refer to the section 2.1 of this manual.
- + Do not lift the treadmill by the running mat or the rear transporting wheels. These parts do not lock and are difficult to grab.

ⓘ NOTICE

The treadmill is foldable and thus saves space when it is stored. It also makes it easier to transport.

4.3.1 Folding Up the Treadmill

⚠ WARNING

- + Do not connect the equipment to the power supply when it is folded up. Try not to operate the equipment when it is folded up.
- + The running surface must have come to a complete stop before folding.

⚠ CAUTION

- + Do not lean on the equipment when it is folded and do not place anything on top of it that may make the equipment unstable or fall down.

▶ ATTENTION

- + Make sure that nothing is standing next to or on top of the treadmill that can be spilled or thrown or that makes it impossible to fold the treadmill.

1. Turn off the on/off switch and remove the plug from the outlet.
2. Use both hands to grab the supportive bar directly under the rear part of the running mat so that you have a stable lifting point.
3. Make sure that the hydraulic brake is correctly locked and tilt the treadmill forward.
4. Make sure that you are standing safely and make sure that the locking mechanism is secure by pulling the equipment backwards and it does not move.

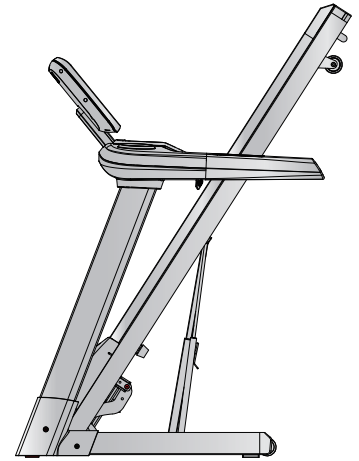

4.3.2 Unfolding the Treadmill

▶ ATTENTION

- + Make sure that nothing is standing next to or on top of the treadmill that can be spilled or thrown or that makes it impossible to unfold the treadmill.

1. Stand behind the treadmill and push the device slightly forward towards the display.
2. To release the hydraulic brake lock, use your left foot to push the upper part of the hydraulic brake slightly forward until the lock releases and the treadmill can be pulled back.
3. Keep holding the treadmill.

The hydraulic brake lowers itself gently downwards.

4. Once the treadmill has lowered $\frac{2}{3}$, you can let go of the treadmill.

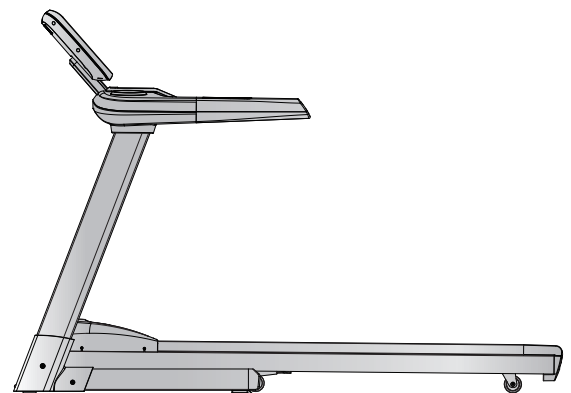

5.1 General Instructions



WARNING

- + Do not make any improper changes to the equipment.



CAUTION

- + Damaged or worn components may affect your safety and the life of the equipment. Therefore, immediately replace damaged or worn components. In such a case, contact the contract partner. The equipment must not be used until it has been repaired. If necessary, use only original spare parts.

ATTENTION

- + In addition to the instructions and recommendations for maintenance and care given here, additional service and/or repair work may be necessary; this must only be carried out by authorised service technicians.

5.2 Faults and Fault Diagnosis

The equipment undergoes regular quality controls during production. Nevertheless, faults or malfunctions may occur. Frequently, individual parts are responsible for these disturbances, an exchange is usually sufficient. Please refer to the following overview for the most common errors and how to correct them. If the equipment still does not function properly, contact your contract partner.

Fault	Cause	Solution
Console is not responding	Safety key missing or not inserted correctly	Check whether Safety Key is inserted and insert if necessary
Running mat slanting	Running mat not centered	Adjust the running mat according to the instructions
Grinding noises		
Running mat slips through/stops	Tape tension/lubrication not correct	Check belt tension/lubrication according to instructions
Display is blank/is not working	<ul style="list-style-type: none"> + Interrupted power connection + Loose cable connections 	<ul style="list-style-type: none"> + Power switch to on + Check whether Safety Key is plugged in + Check cable connections
No pulse display	<ul style="list-style-type: none"> + Sources of interference in the room + unsuitable chest strap + Wrong position of chest strap + Chest strap defective or battery empty + Pulse display defective 	<ul style="list-style-type: none"> + Eliminate sources of interference (e.g. mobile phone, WLAN, lawn mower and vacuum cleaner robot, etc. ...) + Use a suitable chest strap (see RECOMMENDED ACCESSORIES). + Reposition chest strap and/or moisten electrodes + Changing batteries + Check if pulse display by hand pulse possible

5.3 Care and Maintenance

The most important maintenance measure is the care of the running mat. This includes adjustment, re tensioning and lubrication of the running mat. Damage resulting from insufficient or neglected care is not covered by the warranty. You should therefore carry out maintenance checks at regular intervals. Be very careful when adjusting and tightening the running mat, as a strong over voltage or under voltage can cause damage to the equipment. The running mat is adjusted at the factory according to the regulations before delivery. However, it may happen that the running mat slips during transport.

By scanning the QR code with the camera function or QR code scanner app of your smartphone/tablet, a video on general maintenance of a treadmill opens on YouTube. The video serves to illustrate the maintenance points described in this manual.



Please note that the video may not be available in your language or with appropriate subtitles.

If you cannot scan QR codes, you can access all Sport-Tiedje videos on YouTube by first opening YouTube and entering "Sport-Tiedje" in the search field.

5.3.1 Adjusting the Running Mat

During training, the running mat should run as centrally and straight as possible. The alignment of the running mat can change depending on the stress and load. Another reason can be the positioning of the equipment on an uneven surface.

CAUTION

During the following maintenance nobody must be on the treadmill!

1. Let the treadmill run at a speed of 5 km/h.
2. If the running mat deviates to the left, turn the left adjusting screw at the rear end of the device max. one $\frac{1}{4}$ turn clockwise and the right adjusting screw max. one $\frac{1}{4}$ turn anticlockwise.
3. If the running mat deviates to the right, turn the right adjusting screw at the rear end of the device max. $\frac{1}{4}$ turn clockwise and the left adjusting screw max. $\frac{1}{4}$ turn anticlockwise.
4. Then observe the mat for about 30 seconds, as the change is not immediately visible.
5. Repeat this procedure until the running mat is straight again. If the running mat cannot be adjusted, please contact your contract partner.

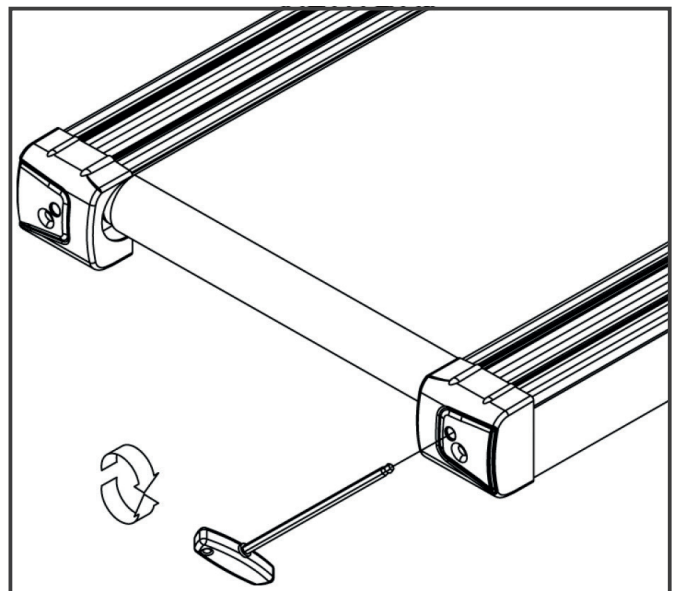

5.3.2 Re-tensioning the Running Mat

If the running mat slips over the rollers during operation (if this is the case, there is a noticeable jerk during running), the running mat must be re tightened.

In most cases, the slipping is caused by stretching of the mat through use. This is perfectly normal.

NOTICE

Re-tensioning is carried out using the same adjusting screws that are used for adjustment.

1. Let the treadmill run at a speed of 5km/h.
2. Turn the left and right adjusting screws directly one after the other, max. one ¼ turn clockwise.
3. Then check whether the running mat continues to slip. If this is the case, you must perform the described procedure again.

5.3.3 Lubricating the Running Mat

If the running mat is not sufficiently lubricated, friction increases significantly and this leads to heavy wear of the endless belt, running plate, motor and circuit board. If you feel an increased friction of the running mat, this is an indication that you should lubricate the mat. However, lubrication should be carried out at least every 3 months or every 50 operating hours. Whichever case comes first.

NOTICE

If your treadmill is equipped with a folding mechanism, you can also lubricate it when it is folded.

1. Raise the running mat slightly.
2. Apply some silicone oil or silicone spray to the entire deck and distribute evenly.
3. Continue turning the belt by hand so that the entire surface between the endless belt and the running plate is lubricated.
4. Wipe off the excess silicone oil or silicone spray.

NOTICE

This maintenance must also be carried out after prolonged non-use of the equipment.

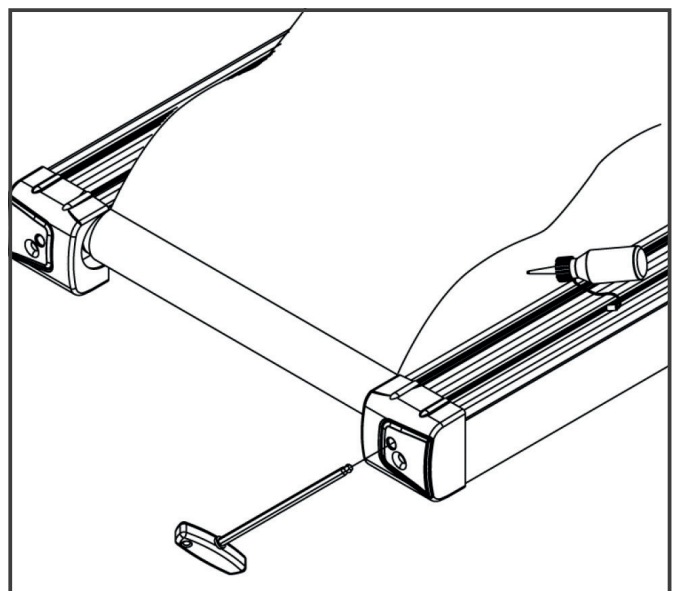

5.4 Maintenance and Inspection Calendar

To avoid damage from body sweat, the equipment must be cleaned with a damp towel (no solvents!) after each training session.

The following routine tasks must be performed at the specified intervals:

Part	Weekly	Monthly	Quarterly
Display console	C	I	
Tension of the running mat			I
Lubrication of the running mat			I
Plastic covers	C	I	
Screws and cable connections			I
Legend: C = clean; I = inspect			

By scanning the QR code with the camera function or QR code scanner app of your smartphone/tablet, a video on general maintenance of a treadmill opens on YouTube. The video serves to illustrate the maintenance points described in this manual.

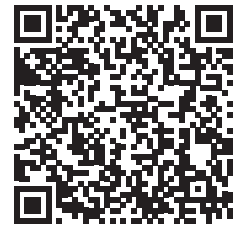

Please note that the video may not be available in your language or with appropriate subtitles.

If you cannot scan QR codes, you can access all Sport-Tiedje videos on YouTube by first opening YouTube and entering "Sport-Tiedje" in the search field.

6 DISPOSAL

At the end of its operational life, this equipment cannot be disposed of in normal household waste. Instead, it must be disposed of via an electricals recycling centre. Further information can be obtained from your local authority's recycling service.



The materials can be recycled as per their symbols. Through the reuse, recycling of materials or other forms of recovery of old equipment, you make an important contribution to the protection of the environment.

To make your training experience even more efficient and pleasant, we recommend that you add suiting accessories to your fitness equipment. For treadmills this could for example be a **floor mat**, which makes your fitness equipment stand more securely and also protects the floor from sweat or **silicone spray** to keep moving parts in good shape and lubricate the running mat. Furthermore, there are additional **handrails** available for some treadmills.

If you have purchased a fitness machine with pulse training and want to train your heart rate, we strongly recommend that you use a compatible **chest strap**, as this ensures optimum transmission of the heart rate.



Our range of accessories offers the highest quality and makes training even better. If you would like to find out more about compatible accessories, please go to the detail page of the product in our webshop (the easiest way is to enter the article number in the search field above) and go to the recommended accessories on this page. Alternatively, you can use the QR code provided. Of course, you can also contact our customer service: by telephone, e-mail, in one of our branches or via our social media channels. We will be happy to advise you!



floor mat



chest strap



chest strap contact gel



handrails



silicone spray

8.1 Serial Number and Model Name

In order to provide you with the best possible service, please have the model name, article number, serial number, exploded drawing and parts list ready. The corresponding contact options can be found in chapter 10 of this operating manual.

NOTICE

The serial number of your equipment is unique. It's located on a white sticker. The exact position of this sticker is shown in the following illustration.

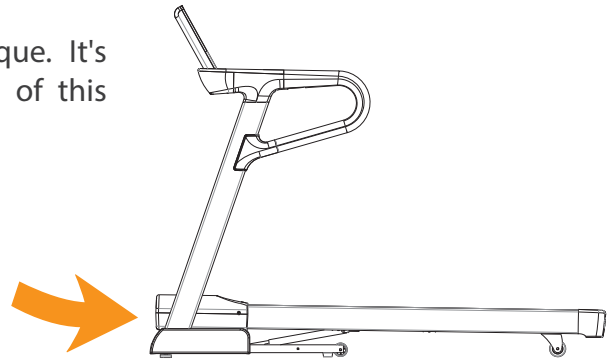

Enter the serial number in the appropriate field.

Serial number:

Brand / Category:

Model Name:

Article Number:

8.2 Parts List

No.	Name	Specification	Qty.
A01	Base assembly		1
A02	Main frame assembly		1
A03	Left column assembly		1
A04	Right column assembly		1
A05	Instruments stand assembly		1
A06	Panel fixing frame assembly		1
A07	Cross armrest tube assembly		1
A08	Lifting frame assembly		1
B01	Front roller	Φ50*t3.0*562	1
B02	Rear roller	Φ46*t3.0*560	1
B03	Air pressure rod		1
B04	Pulse stainless steel sheet		4
B05	Safety lock spring		2
B06	Sleeve		2
B07	Isometric 5# Allen wrench		1
B08	Cross wrench		1
B09	Step sleeve		2
B10	Spring 1		4
C01	Upper cover of color screen panel		1
C02	Panel lower cover		1
C03	Instruments upper cover		1
C04	Instruments lower cover		1
C05	Middle and lower covers of instruments		1
C06	Instruments left side cover		1
C07	Instruments right side cover		1
C08	Left column outer cover		1
C09	Right column outer cover		1
C10	Left column inner cover		1
C11	Right column inner cover		1
C12	Foam armrest		2
C13	Screw hole plug		4

C14	Armrest tube plug		2
C15	Motor upper cover		1
C16	Motor lower cover		1
C17	Left-rear corner guard		1
C18	Right-rear corner guard		1
C19	Oval cushion		4
C20	Cushion		4
C21	Tapered cushion		2
C22	Flat foot pad		2
C23	New handling wheel		2
C24	Adjusting roller		2
C25	Sponge grip		2
C26	Safety lock clip		1
C27	Safety lock		1
C28	Grip pulse upper cover		1
C29	Grip pulse lower cover		1
C30	Adjustable foot pad		2
C31	Multi wedge belt		1
C32	Ring wire plug		2
C33	Plastic gasket		2
C34	EVA pad	1190*20*2.0	2
C35	EVA pad	80*64*3.0	1
C36	Left bottom shield		1
C37	Right bottom shield		1
C38	Sidebar		2
C39	Running belt		1
D01	Instruments		1
D02	Control circuit board		1
D03	Button board		1
D04	EKG grip pulse upper line		1
D05	EKG grip pulse lower line		2
D06	Safety switch upper line		1
D07	Safety switch lower line		1
D08	Instruments upper line		1
D09	Instruments middle line 1		1

D10	Instruments lower line		1
D11	Magnetic sensor		1
D12	Magnetic ring		1
D13	Core		1
D14	Standard power cable		1
D15	Square boat-shaped switch		1
D16	Power socket		1
D17	Overload protector		1
D18	AC individual line	Line length 200, blue	1
D19	AC individual line	Line length 200, brown	2
D20	AC individual line	Line length 350, brown	1
D21	AC individual line	Line length 350, blue	1
D22	Grounding wire	Yellow-green	1
D23	DC motor		1
D24	Running board		1
D25	Lifting motor		1
D26	Control panel board		1
D27	Upper wire of the control panel	L=450	1
D28	Lower wire of the control panel	L=1050	1
E01	Type-I lock nut	M8	20
E02	Type-I lock nut	M10	6
E03	Hexagon socket flat round head screw	M10*90, tooth length 20	1
E04	Hexagon socket flat round head screw	M10*45, tooth length 20	1
E05	Hexagon socket flat round head screw	M10*30, tooth length 15	2
E06	Half round head square neck bolt	M10*30, tooth length 15	2
E07	Hexagon socket flat round head screw	M8*80, tooth length 15	2
E08	Hexagon socket flat round head screw	M8*70, tooth length 20	2
E09	Hexagon socket head cap screw	M8*65, full teeth	2
E10	Hexagon socket head cap screw	M8*55, full teeth	1
E11	Hexagon socket flat round head screw	M8*40, tooth length 20	2
E12	Half round head square neck bolt	M8*35, tooth length 15	6
E13	Hexagon socket flat round head screw	M8*30, tooth length 15	3
E14	Hexagon socket countersunk head screw	M8*25, full teeth	4
E15	Hexagon socket flat round head screw	M8*15, full teeth	26
E16	Cross recessed pan head screw	M5*16	2

E17	Cross recessed pan head screw	M5*12	7
E18	Cross recessed pan head screw	M5*8	1
E19	Cross recessed pan head tapping screw	ST4.2*30	2
E20	Cross recessed pan head tapping screw	ST4.2*25	3
E21	Cross recessed pan head tapping screw	ST4.2*20	2
E22	Cross recessed pan head tapping screw	ST4.2*12	26
E23	Cross recessed pan head self-drilling tapping screw	ST4.2*12	17
E24	Cross recessed countersunk head tapping screw	ST4.2*12	6
E25	Cross recessed pan head tapping screw	ST2.9*8	4
E26	Cross recessed pan head tapping screw	ST2.9*6.0	20
E27	Cross recessed pan head tapping screw	ST2.5*6	4
E28	Large washer, grade C nail	φ10*φ26*2.0	6
E29	Plain washer, grade C	8	8
E30	Standard spring washer	8	2
E31	Internal teeth locking washer	10	2
E32	Internal teeth locking washer	8	27
E33	Hexagon socket flat round head screw	M8*45, tooth length 20	1
E34	Cross pan head self-drilling screw	ST4.2*15	6
H01	USB module	USB module assembly	1
H02	USB cable		1
H03	Audio socket cable		1
H04	Cross recessed pan head tapping screw ST2. 9*8		2
G01	Horn	Horn assembly	2
G02	Horn cable		2
G03	MP3 cable		1
G04	Cross recessed pan head tapping screw ST2. 9*8		8
J01	Filter	Filter	1
J02	Reactor		1
J03	AC individual line, length 350, blue		1
J04	Grounding wire, length 350, yellow-green		1
J05	Cross recessed pan head self-drilling tapping screw ST4. 2*12		4
K01	Wireless heart rate lower line	Wireless heartbeat	
K02	POLAR launcher		
K03	POLAR wireless receiver		

8.3 Exploded Drawing

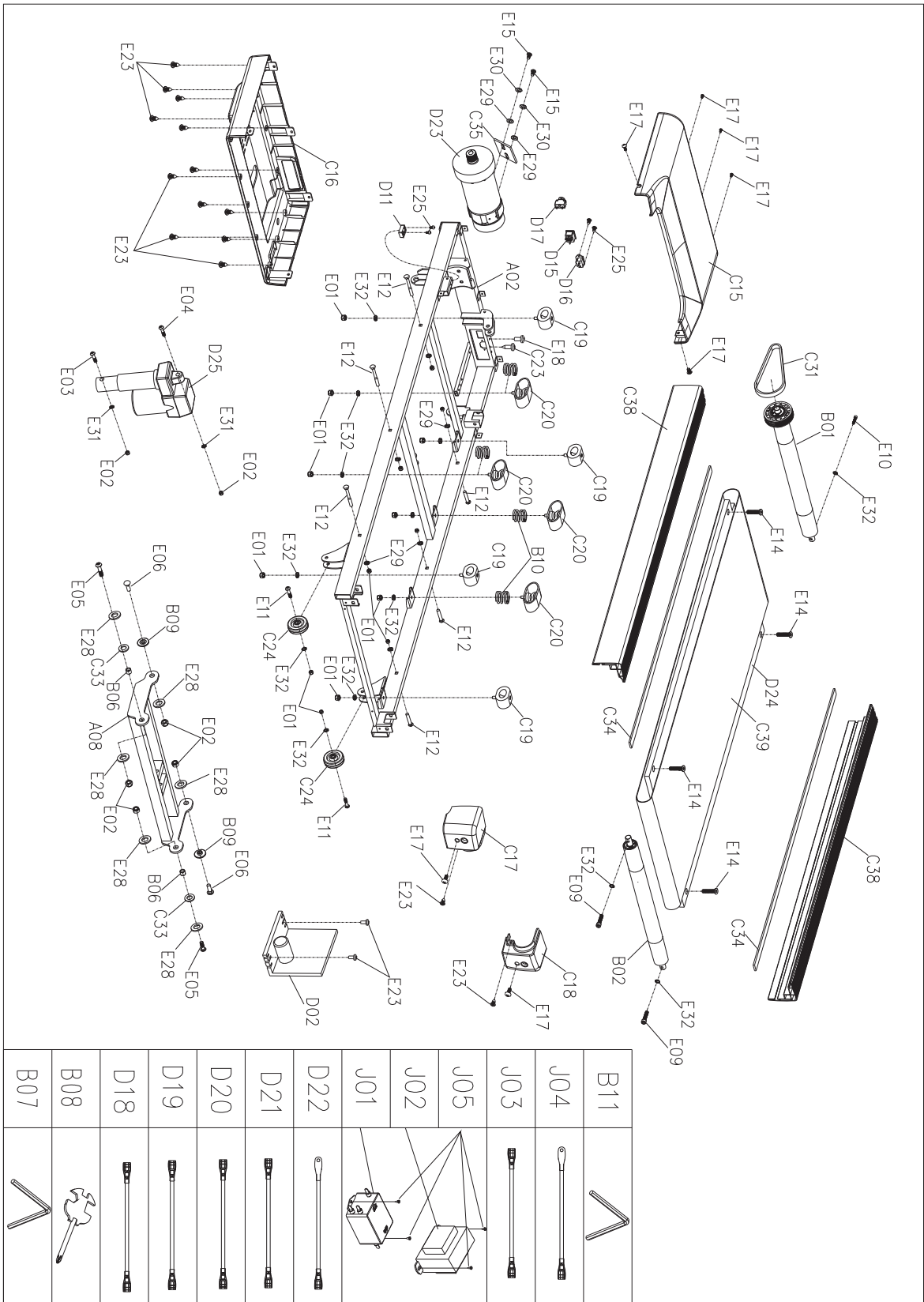

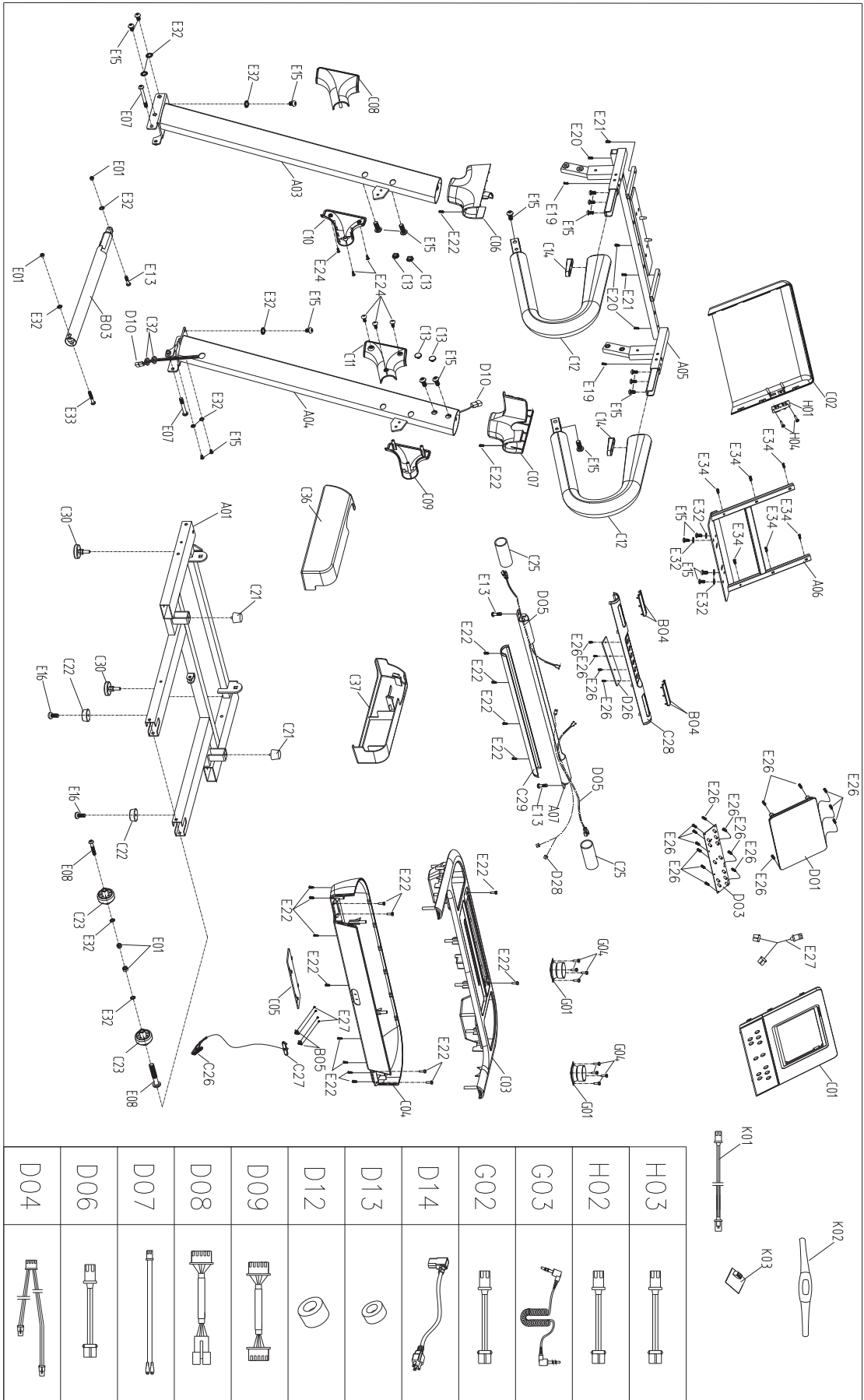

Training equipment from Darwin® is subject to strict quality control. However, if a fitness equipment purchased from us does not work perfectly, we take it very seriously and ask you to contact our customer service as indicated. We are happy to help you by phone via our service hotline.

Error Descriptions

Your fitness equipment is developed for long-term, high-quality training. However, should a problem arise, please first read the operating instructions. For further assistance, please contact your contract partner or call our service hotline. To ensure your problem is solved as quickly as possible, please describe the defect as exactly as possible.

In addition to the statutory warranty, we provide a warranty for every fitness equipment purchased from us according to the following provisions.

Your statutory rights are not affected.

Warranty

The warranty is the first/original buyer and/or any person who received a newly purchased product as a gift from the original buyer.

Warranty period

The warranty periods, shown on our web shop, begin on delivery of the fitness equipment. The respective warranty periods for your equipment can be found on its product website.

Repair Costs

According to our choice, there will either be a repair, a replacement of individual damaged parts or a complete replacement. Spare parts, that have to be mounted while assembling the equipment, have to be replaced by the warranty personally and are not a part of repair. After the expiration of the warranty period for repair costs, a pure parts warranty applies, which does not include the repair, installation and delivery costs.

The terms of use are defined as follows:

- + Home use: solely for private use in private households up to 3 hours per day
- + Semi-professional use: up to 6 hours per day (e. g. rehabilitation centres, hotels, clubs, company gyms)
- + Professional use: more than 6 hours per day (e. g. commercial gyms)

Warranty Service

Within the warranty period, equipment which develops faults as a result of material or manufacturing defects, will be repaired or replaced at our discretion. Ownership of equipment or parts of equipment which have been replaced is transferred to us. The warranty period is not extended nor does a new warranty period begin following repair or replacement under the warranty.

Warranty Conditions

For the warranty to be valid, the following steps must be taken:

Please contact our customer service by email or phone. If the product under warranty has to be sent in for repair, the seller bears costs. After expiry of the warranty, the buyer bears the costs of transport and insurance. If the fault is covered by our warranty, you will receive a new or repaired equipment in return.

Warranty claims are invalid in case of damage resulting from:

- + misuse or improper handling
- + environmental influences (moisture, heat, electrical surge, dust, etc.)
- + failure to follow the current safety measures for the equipment
- + failure to follow the operating instructions
- + use of force (e. g. hitting, kicking, falling)
- + interventions which were not carried out by one of our authorized service centres
- + unauthorised repair attempts

Proof of Purchase and Serial Number

Please make sure that you are able to provide the appropriate receipt when claiming on your warranty. So that we can clearly identify the model of your equipment, and for the purposes of our quality control, you will need to give the serial number of your equipment, when contacting the service team. Where possible please have your serial number and your customer number ready when you call our service hotline. It will help us to deal with your request swiftly.







































If you cannot find the serial number on your fitness equipment, our service team is at your disposal to offer further information.

Service outside of the Warranty Period

We are also happy to issue an individual cost estimate if there is a problem with your fitness equipment after the warranty has expired, or in cases which do not fall under the terms of the warranty, e. g. normal wear and tear. Please contact our customer service team to find a quick and cost-effective solution to your problem. In such a case you will be responsible for the delivery costs.

Communication

Many problems can be solved just by speaking to us as your specialist supplier. We know how important it is to you as a user of the fitness equipment to have problems solved quickly and simply, so you can enjoy working out with minimal interruption. For that reason, we also want to resolve your queries quickly and in a straightforward manner. Thus, please always keep your customer number and the serial number of the faulty equipment handy.

DE	DK	FR
<p>TECHNIK</p> <p> +49 4621 4210-900</p> <p> +49 4621 4210-698</p> <p> technik@sport-tiedje.de</p> <p> Öffnungszeiten entnehmen Sie unserer Homepage.</p>	<p>TEKNIK OG SERVICE</p> <p> 80 90 16 50</p> <p>+49 4621 4210-945</p> <p> info@fitshop.dk</p> <p> Åbningstider kan findes på hjemmesiden.</p>	<p>TECHNIQUE & SERVICE</p> <p> +33 (0) 189 530984</p> <p>+49 4621 42 10 933</p> <p> info@fitshop.fr</p> <p> Vous trouverez les heures d'ouverture sur notre site Internet.</p>
<p>SERVICE</p> <p> 0800 20 20277 (kostenlos)</p> <p> 04621 4210 - 0</p> <p> info@sport-tiedje.de</p> <p> Öffnungszeiten entnehmen Sie unserer Homepage.</p>	<p>PL</p> <p>DZIAŁ TECHNICZNY I SERWIS</p> <p> 22 307 43 21</p> <p>+49 4621 42 10-948</p> <p> info@fitshop.pl</p> <p> Godziny otwarcia można znaleźć na stronie głównej.</p>	<p>BE</p> <p>TECHNIQUE & SERVICE</p> <p> 02 732 46 77</p> <p>+49 4621 4210 933</p> <p> info@fitshop.be</p> <p> Vous trouverez les heures d'ouverture sur notre site Internet.</p>
UK	NL	INT
<p>CUSTOMER SUPPORT</p> <p> 00800 2020 2772</p> <p>+494621 4210 944</p> <p> info@sport-tiedje.co.uk</p> <p> You can find the opening hours on our homepage.</p>	<p>TECHNISCHE DIENST & SERVICE</p> <p> +31 172 619961</p> <p> info@fitshop.nl</p> <p> De openingstijden vindt u op onze homepage.</p>	<p>TECHNICAL SUPPORT & SERVICE</p> <p> +49 4621 4210-944</p> <p> service-int@sport-tiedje.de</p> <p> You can find the opening hours on our homepage.</p>
ES	AT	CH
<p>TECNOLOGÍA Y SERVICIOS</p> <p> 911 238 029</p> <p> info@fitshop.es</p> <p> Consulta nuestro horario de apertura en la página web.</p>	<p>TECHNIK & SERVICE</p> <p> 0800 20 20277 (Freecall)</p> <p>+49 4621 42 10-0</p> <p> info@sport-tiedje.at</p> <p> Öffnungszeiten entnehmen Sie unserer Homepage.</p>	<p>TECHNIK & SERVICE</p> <p> 0800 202 027</p> <p>+49 4621 42 10-0</p> <p> info@sport-tiedje.ch</p> <p> Öffnungszeiten entnehmen Sie unserer Homepage.</p>

Please find a detailed overview including address and opening hours for all stores of the Sport-Tiedje Group in Germany and abroad on the following website:

www.sport-tiedje.com/en/stores

WE LIVE FITNESS

WEBSHOP AND SOCIAL MEDIA

Sport-Tiedje is Europe's largest specialist store for home fitness equipment with currently over 70 stores and one of the world's most renowned online mail order companies for fitness equipment. Private customers order via the 25 web shops in the respective national language or have their desired equipment assembled on site. In addition, the company supplies fitness studios, hotels, sports clubs, companies and physio practices with professional equipment for endurance and strength training.

Sport-Tiedje offers a wide range of fitness equipment from renowned manufacturers, high-quality in-house developments and comprehensive services, such as a build-up service and sports scientific advice before and after the purchase. The company employs numerous sports scientists, fitness trainers and competitive athletes.

Visit us also on our social media platforms or our blog!

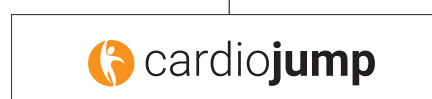
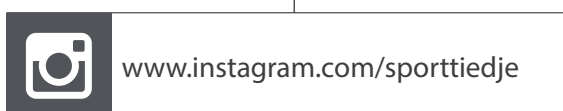

Notes



DARWIN **TM70** Touch