

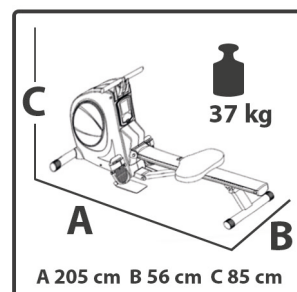

# Assembly and Operating Instructions



DFRM50.01.04

Art. No. DF-RM50

DARWIN RM 50



# Content

<b>1</b>	<b>GENERAL INFORMATION</b>	<b>7</b>
1.1	Technical Data	7
1.2	Personal Safety	8
1.3	Set-Up Place	9
<b>2</b>	<b>ASSEMBLY</b>	<b>10</b>
2.1	General Instructions	10
2.2	Scope of Delivery	11
2.3	Assembly	12
2.4	Adjustment of the rowing machine	16
2.4.1	Adjustment	16
2.4.2	Adjustment of the Pedals	16
2.4.3	Fill and empty the tank	17
<b>3</b>	<b>OPERATING INSTRUCTIONS</b>	<b>18</b>
3.1	Console Display	18
3.2	Button Functions	19
3.3	Turning On and Setting Up the Machine	20
3.4	Programmes	21
3.4.1	MANUAL	21
3.4.2	RACE	21
3.4.3	RECOVERY	22
3.5	Further Information	23
3.6	Notes on correct rowing	23
<b>4</b>	<b>STORAGE AND TRANSPORT</b>	<b>26</b>
4.1	General Instructions	26
4.2	Transportation Wheels	26
4.3	Storage	27
<b>5</b>	<b>TROUBLESHOOTING, CARE AND MAINTENANCE</b>	<b>28</b>
5.1	General Instructions	28
5.2	Faults and Fault Diagnosis	28
5.3	Maintenance and Inspection Calendar	29
<b>6</b>	<b>DISPOSAL</b>	<b>29</b>
<b>7</b>	<b>RECOMMENDED ACCESSORIES</b>	<b>30</b>

<b>8</b>	<b>ORDERING SPARE PARTS</b>	<b>31</b>
8.1	Serial Number and Model Name	31
8.2	Parts List	32
8.3	Exploded Drawing	35
<b>9</b>	<b>WARRANTY</b>	<b>36</b>
<b>10</b>	<b>CONTACT</b>	<b>38</b>

## Dear customer,

Thank you for choosing a high-quality equipment of the brand Darwin®. Darwin® offers sports and fitness equipment for the sophisticated home sport and the equipment of fitness studios and business customers. With Darwin® fitness equipment, the focus is on what sport is all about: maximum performance! Therefore, the equipment is developed in close consultation with athletes and sports scientists. Because athletes know best what makes perfect fitness equipment.

Further information can be found at [www.sport-tiedje.com](http://www.sport-tiedje.com).

### Intended Use

The equipment may only be used for its intended purpose.

The equipment is only suitable for home use. The equipment is not suitable for semi-professional (e.g. hospitals, associations, hotels, schools, etc.) and commercial or professional use (e.g. fitness studios).

## Legal Notice

Sport-Tiedje GmbH  
Europe's No. 1 for home fitness

International Headquarters  
Flensburger Straße 55  
24837 Schleswig  
Germany

Management:  
Christian Grau  
Sebastian Campmann  
Dr. Bernhard Schenkel  
No. HRB 1000 SL  
Local Court Flensburg  
European VAT Number: DE813211547

## Disclaimer



©2010 Darwin® is a registered brand of the company SportTiedje GmbH. All rights reserved. Any use of this trademark without the explicit written permission of Sport-Tiedje is prohibited.

Product and manual are subject to change. Technical data can be changed without advance notice.

## ABOUT THIS MANUAL

Please carefully read the entire manual before installation and first use. The manual will help you to quickly set up the system and explains how to safely use it. Make sure that all persons exercising with the equipment (especially children and persons with physical, sensory, mental or motor disabilities) are informed about this manual and its contents in advance. In case of doubt, responsible persons must supervise the use of the equipment.



This equipment has been manufactured according to the latest safety knowledge. As far as possible, potential safety hazards which could cause injury have been eliminated. Make sure to carefully follow the instructions and that all parts are securely in place. If required, read through the instructions again to correct any mistakes.

Please pay close attention to the safety and maintenance instructions given here. The contract partner cannot be held liable for damage to health, accidents or damage to the equipment when it is not used in accordance with these instructions.

The following safety instructions may appear in this manual:

► **ATTENTION**

This notice indicates potentially hazardous situations which, if not avoided, may result in property damage.

⚠ **CAUTION**

This notice indicates potentially hazardous situations which, if not avoided, may result in slight or minor injuries!

⚠ **WARNING**

This notice indicates potentially hazardous situations which, if not avoided, may result in death or serious injuries!

⚠ **DANGER**

This notice indicates potentially hazardous situations which, if not avoided, will result in death or serious injuries!

ⓘ **NOTICE**

This notice indicates further useful information.

Retain these instructions in a safe place for future reference, maintenance or when ordering replacement parts.

## 1.1 Technical Data

### LED display of:

- + Strokes, Strokes per minute
- + Time in min.
- + Distance in m
- + Time/500m: average/current
- + Calories in kcal
- + Heart rate (when using a chest strap)

Total number of training programmes:	3
Manual programme:	1
RACE programme:	1
RECOVERY programme:	1

### Weight and dimensions:

Article weight (gross, including packaging):	48 kg
Article weight (net, without packaging):	37 kg

Packaging dimensions (L x W x H): 115 cm x 57 cm x 52 cm

Set-up dimensions (L x W x H): 205 cm x 56 cm x 85 cm

Maximum user weight: 110 kg

## 1.2 Personal Safety

### **DANGER**

- + Before you start using the equipment, you should consult your physician that this type of exercise is suitable for you from a health perspective. Particularly affected are persons who: have a hereditary disposition to high blood pressure or heart disease, are over the age of 45, smoke, have high cholesterol values, are overweight and/or have not exercised regularly in the past year. If you are under medical treatment that affects your heart rate, medical advice is absolutely essential.
- + Note that excessive training can seriously endanger your health. Please also note that heart rate monitoring systems can be inaccurate. If you notice any signs of weakness, nausea, dizziness, pain, shortness of breath, or other abnormal symptoms, stop exercising immediately and seek advice from your doctor if necessary.

### **WARNING**

- + This equipment may not be used by children under the age of 14.
- + Children should not be allowed unsupervised access to the equipment.
- + Persons with disabilities must have a medical license and must be under strict observation when using the equipment.
- + The equipment is strictly for use by one person at a time.
- + If your equipment provides a safety key, the clip of the safety key must be attached to your clothing before starting your training. In the event of a fall, the EMERGENCY STOP of the equipment can be initiated.
- + Keep your hands, feet and other body parts, hair, clothing, jewellery and other objects well clear of moving parts.
- + During use, wear suitable sports clothing rather than loose or baggy clothing. When wearing sports shoes, make sure they have suitable soles, preferably made of rubber or other non-slip materials. Shoes with heels, leather soles, studs or spikes are unsuitable. Never exercise barefoot.

### **CAUTION**

- + If your equipment needs to be connected to the power supply with a mains cable, make sure that the cable is not a potential tripping hazard.
- + Make sure that nobody is within the range of motion of the equipment during training so as not to endanger you or other persons.

### **ATTENTION**

- + Do not insert any objects of any kind into the openings of the device.



## 1.3 Set-Up Place

### ⚠ WARNING

- + Do not place the equipment in main corridors or escape routes.

### ⚠ CAUTION

- + Choose a location in which to place the equipment such that there is enough free space/clearance to the front, the rear and to the sides of the equipment. Make sure that you leave at least 30 cm on each side of the equipment and at least 15 cm in front of and behind the equipment as a training zone. This is the minimum required area in order to safely use the equipment. The recommended free zone around the equipment should be at least 60 cm on each side and 45 cm in front of and behind the equipment.
- + The training room should be well ventilated during training and not be exposed to any draughts.
- + Choose the place in which to set up the equipment such that there is enough free space/clearance to the front, the rear and to the sides of the equipment.
- + The set-up and mounting surface of the equipment should be flat, loadable and solid.

### ▶ ATTENTION

- + The device may only be used in one building, in sufficiently tempered and dry rooms (ambient temperatures between 10°C and 35°C). The equipment should not be used outdoors or in rooms with high humidity (over 70%) like swimming pools.
- + A floor protective mat/equipment underlay can help to protect high-quality floor coverings (parquet, laminate, cork, carpets) from dents and sweat and can help to level out slight unevenness.

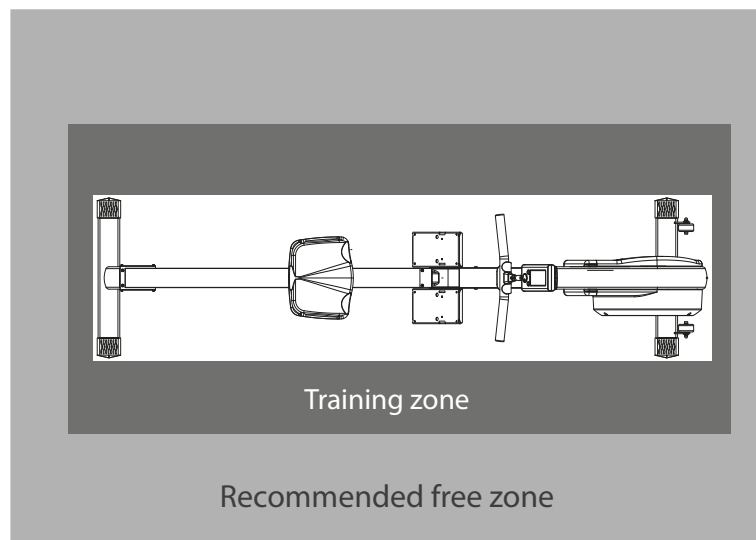

## 2.1 General Instructions



### DANGER

- + Do not leave any tools, packaging materials such as foils or small parts lying around, as otherwise there is a danger of suffocation for children. Keep children away from the equipment during assembly.



### WARNING

- + Pay attention to the instructions attached to the equipment in order to reduce the risk of injuries.



### CAUTION

- + Do not open the packaging when it is lying on its side.
- + Ensure to have sufficient room for movement in each direction during assembly.
- + The assembly of the equipment must be carried out by at least two adults. If in doubt, seek the help of a third technically skilled person.



### ATTENTION

- + To prevent damage to the equipment and the floor, assemble the equipment on a mat or packaging board.



### NOTICE

- + In order to make the assembly as simple as possible, some screws and nuts to be used can already be pre-assembled.
- + Ideally, assemble the equipment at its later set-up place.

## 2.2 Scope of Delivery

The scope of delivery consist of the following parts. At the beginning, check whether all parts and tools belonging to the device are included in the scope of delivery and whether damage has occurred. In the event of complaints, the contractual partner must be contacted directly.

### CAUTION

If parts of the scope of delivery are missing or damaged, the assembly must not be carried out.

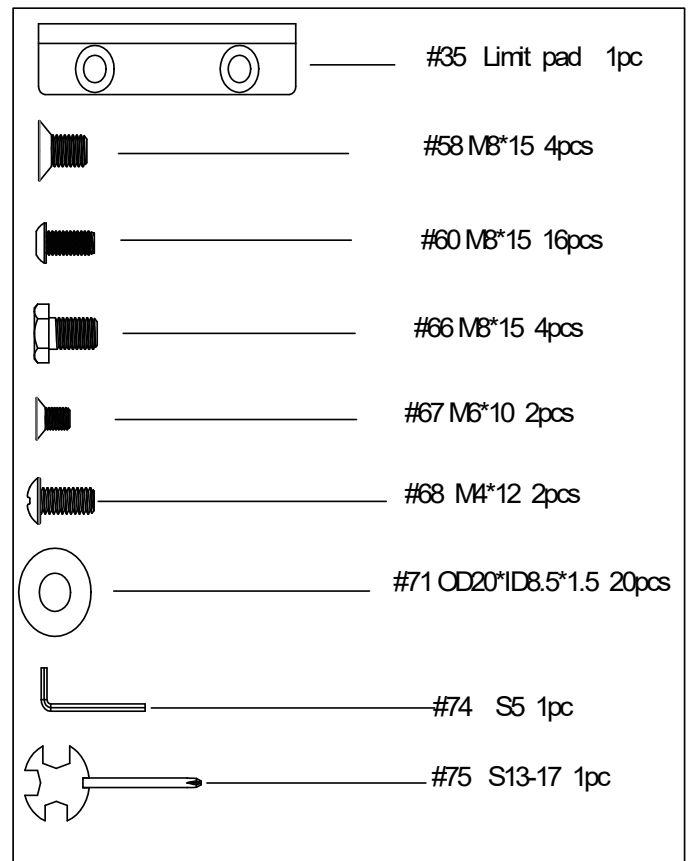
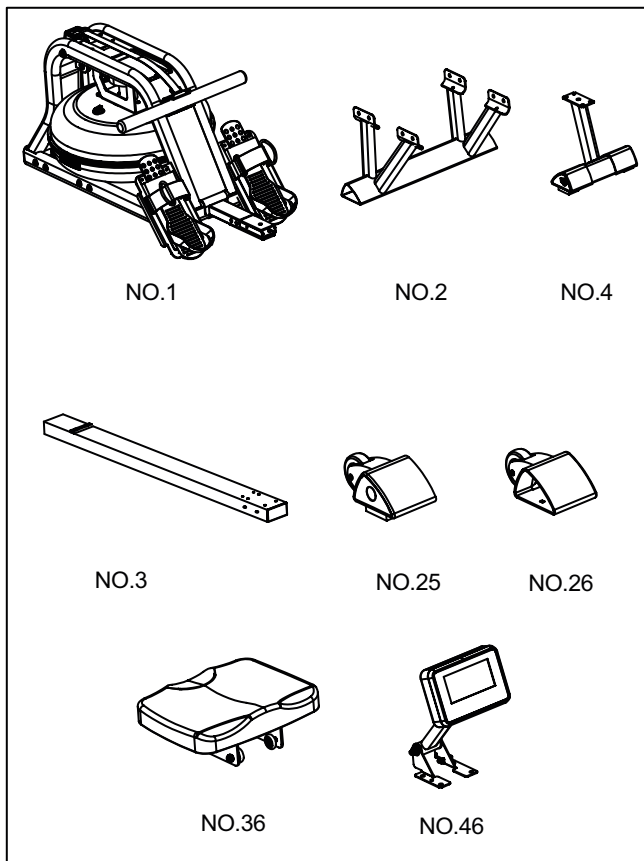

## 2.3 Assembly

Before assembly, take a close look at the individual assembly steps shown and carry out the assembly in the order given.

### ① NOTICE

First loosely screw all parts together and check that they fit properly. Tighten the screws using the tool only when you are instructed to do so.

### Step 1

1. Turn the Slide Rail (3) and Seat (36) upside down as shown below.
2. Slide the Seat (36) onto the Slide Rail (3).
3. Screw in the Stopper (35) with two Flat Cross Screws (67).
4. Then attach the Rear Stand (4) to the Slide Rail (3) with four Washers (71) and four Outer Hex Screws (66).
5. Tighten with the Screwdriver-Tool (75).

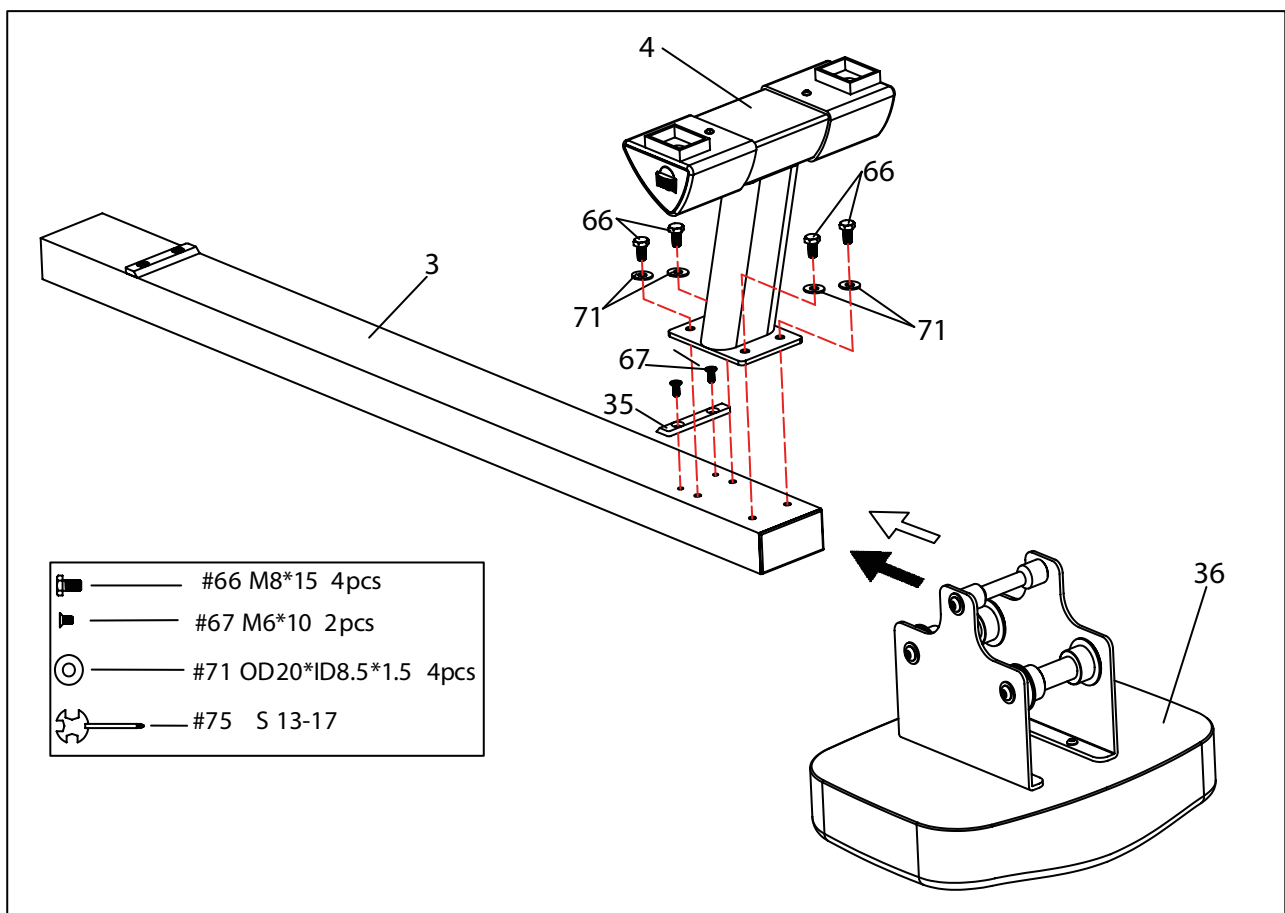

## Step 2

1. Attach the Left & Right End Caps (25 & 26) to Front Stand (2).
2. Then tighten with two Cross Screws (68) using the Screwdriver-Tool (75).

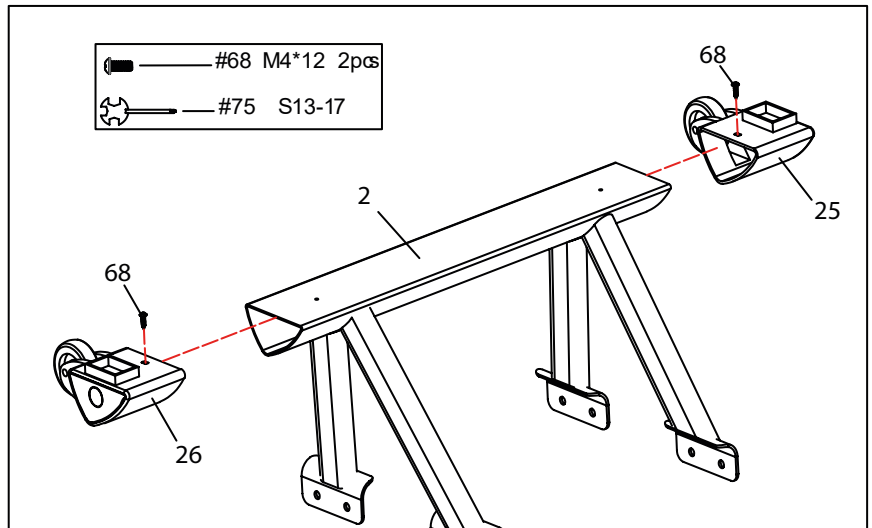

## Step 3

1. Stand the Main Frame (1) upright as shown below.

### ► ATTENTION

You can put 3-4 screws into the holes first, and tighten them by hand. After all the screws are in, tighten them with the key.

2. Attach Front Stand (2) to Main Frame (1) using eight Washers (71) and eight Screws (60).
3. Tighten with the Allen Key (74).

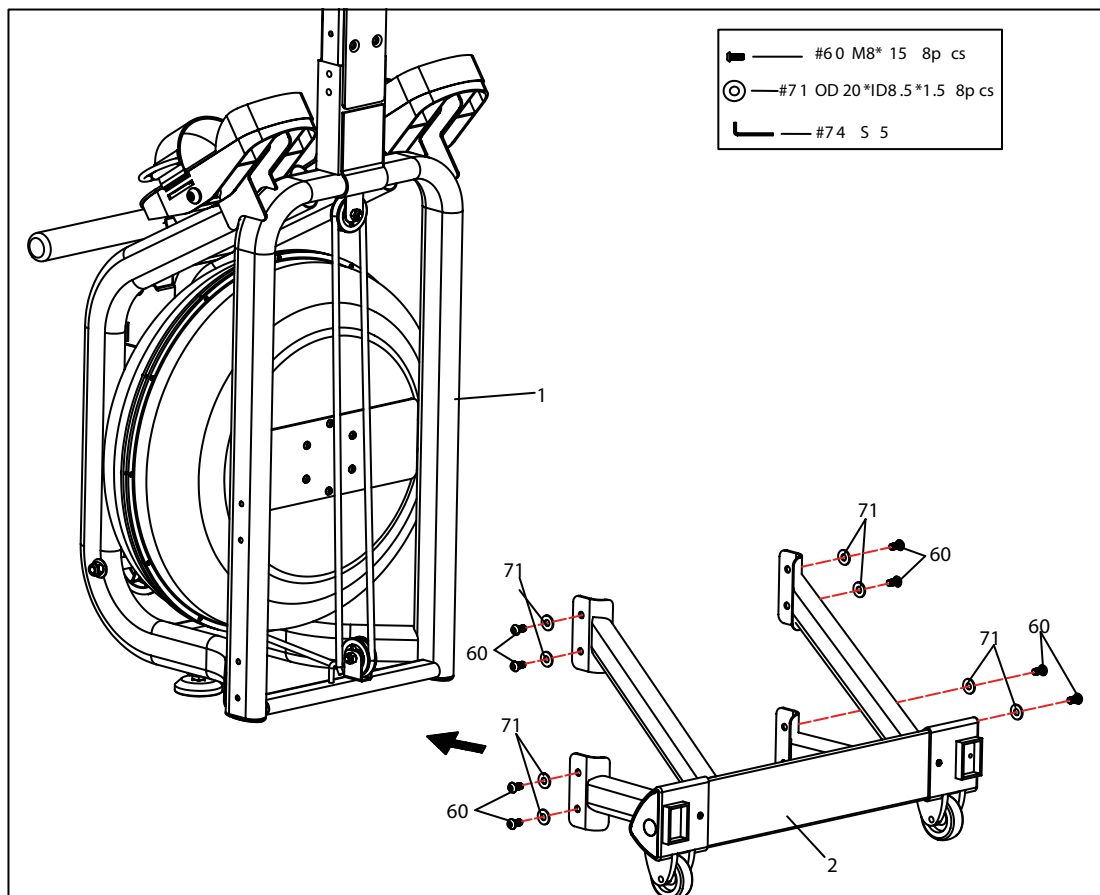

## Step 4



### CAUTION

Move the Seat (36) to the front of the Slide Rail (3) before assembly to prevent it from sliding down during assembly.

1. Attach the Slide Rail (3) to the Main Frame (1) using four Washers (71), four Screws (60) and four Flat Screws (58).
2. Insert all eight screws partially into the holes first and then tighten with the Allen Key (74).

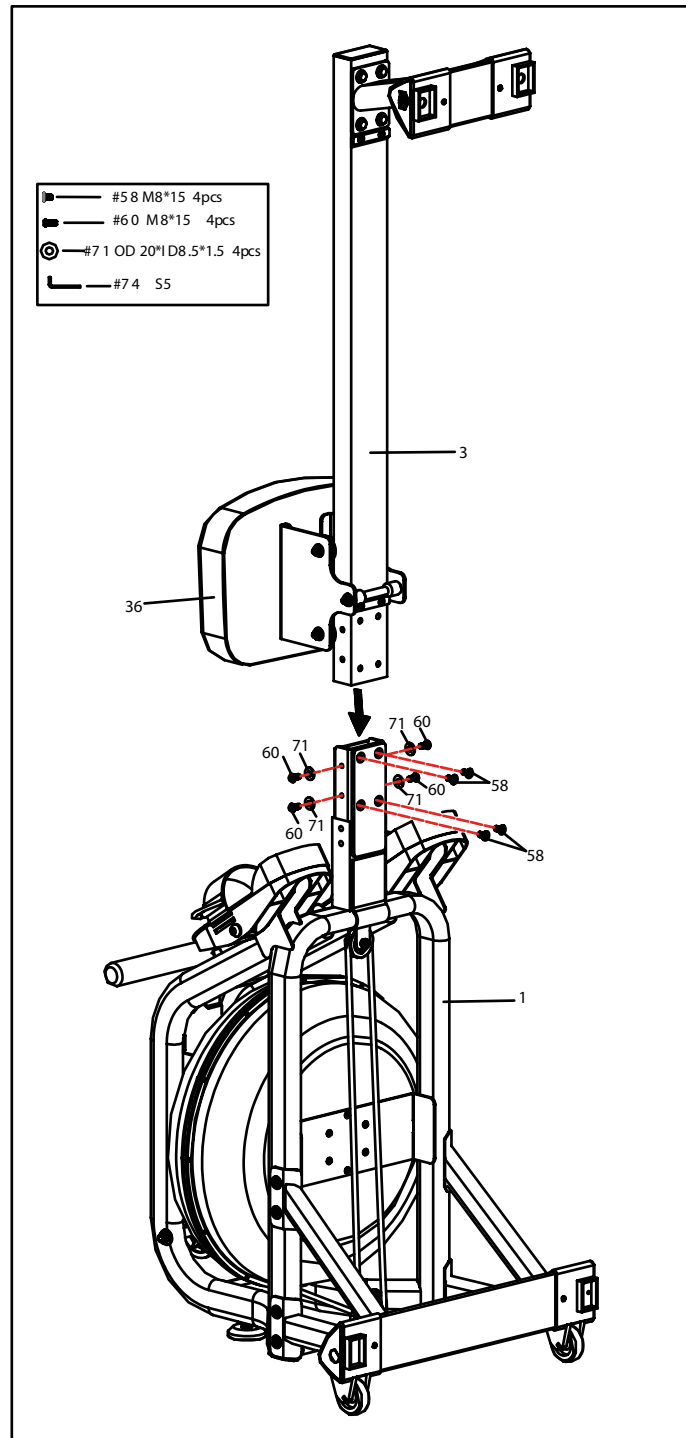

## Step 5

Attach the frame for the computer (5) to the Main Frame (1), with four Washers (71) and four Screws (60). Tighten them with the Allen Key (74).

*Assembly is now complete.*

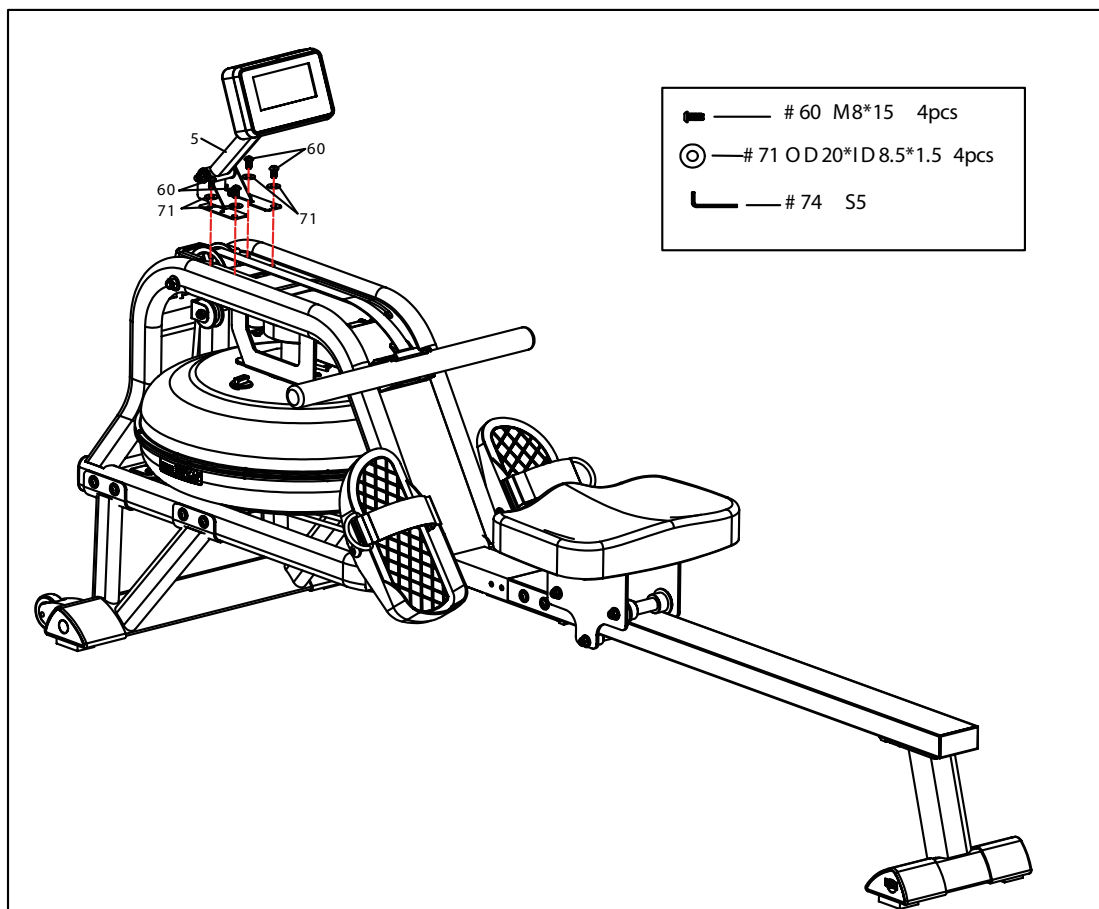

## Step 6

If the floor is uneven, you can stabilize the equipment by adjusting the End Caps on the Rear Stand (4).

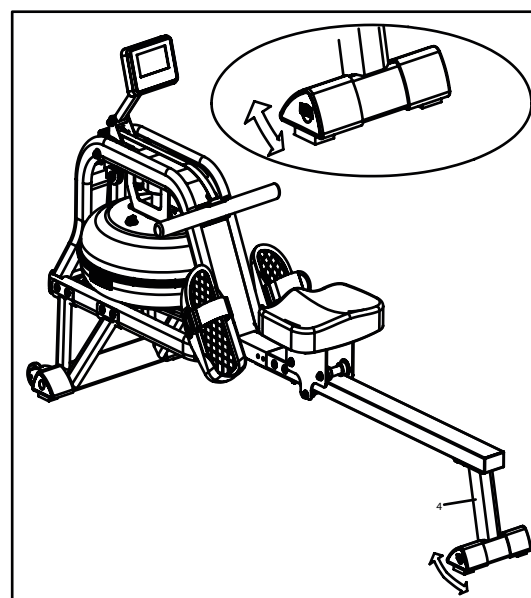

## 2.4 Adjustment of the rowing machine

### 2.4.1 Adjustment

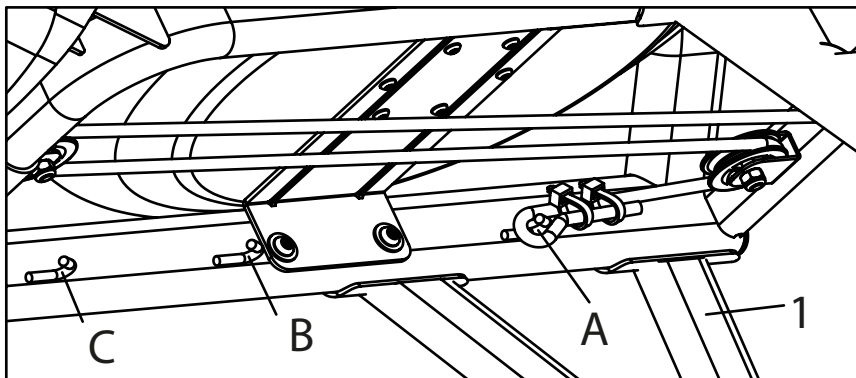

Located on the inside of the frame under the water tank are 3 hooks (A, B, C). If you hook the bungee cord on to B or C, it increases the assisted return of the rowing belt. C is the fastest return. Use caution when adjusting the bungee cord.

### 2.4.2 Adjustment of the Pedals

The pedal strap is adjustable and can be personalized to fit the user's foot size.

To adjust the pedal strap, remove the Velcro end of the strap from the mesh side by pulling it upward then outwards.

Once removed, you may increase the opening of the pedal strap by pulling the strap over the foot up and inwards.

To tighten, pull the Velcro end of the pedal strap upward then inwards and down to secure it to the mesh side of the strap.

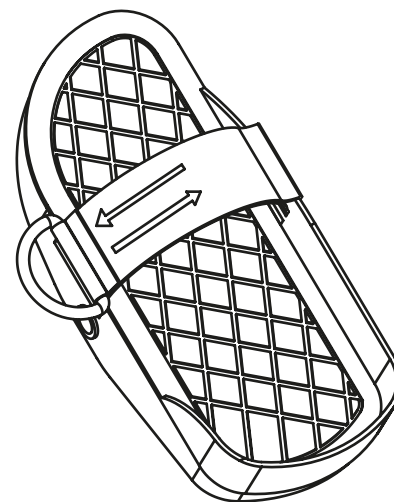



## 2.4.3 Fill and empty the tank

### ⚠ CAUTION

- + The water inside the tank must not be drunk and must be disposed of after use.

### ▶ ATTENTION

- + Fill the tank only with tap water. Do not use distilled water.
  - + Do not fill the water tank above the maximum capacity, this may void the warranty. The maximum filling quantity can be found in the section on the water level in this chapter.
  - + To prevent algae formation, limescale and possible damage to the tank, we recommend the use of chlorine tablets. Only use chlorine tablets for rowing machines.
1. Remove the fill plug (33) from the upper tank (12).
  2. Filling: Place the funnel (77) in the tank opening and fill the tank using the pumping siphon (76) or a measuring cup and a bucket (see figure A).
  3. Emptying: Place a bucket next to the rowing machine and pump the water with the pumping siphon (76) from the tank into the bucket (see fig. B).
  4. After filling or emptying the tank, insert the fill plug (33) into the tank (12) and wipe off excess water from the frame.

### Water level

The water level indicator is located on the top of the tank (see Fig. A). The base resistance can be adjusted via the water quantity. Please refer to the following table for the optimum quantity (1 = very light; 6 = heavy):

Level	Water quantity
1	8.5 L
2	9.5 L
3	10.5 L
4	11.1 L
5	11.9 L
6	12.8 L

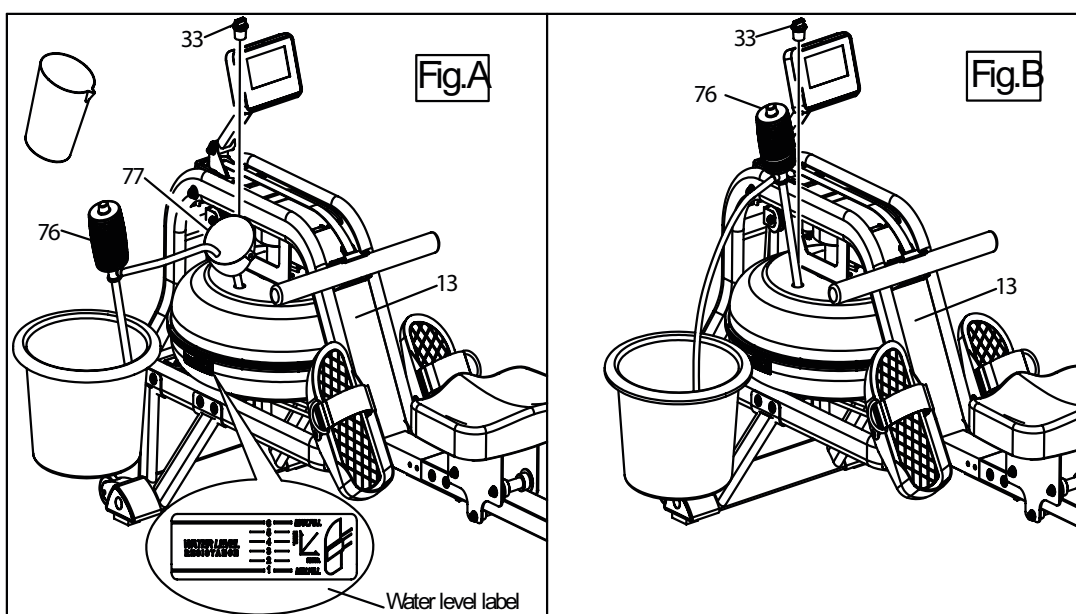

## 3 OPERATING INSTRUCTIONS

### ① NOTICE

Familiarise yourself with all the functions and setting options of the device before starting training. Have the proper use of this product explained to you by a specialist.

### 3.1 Console Display

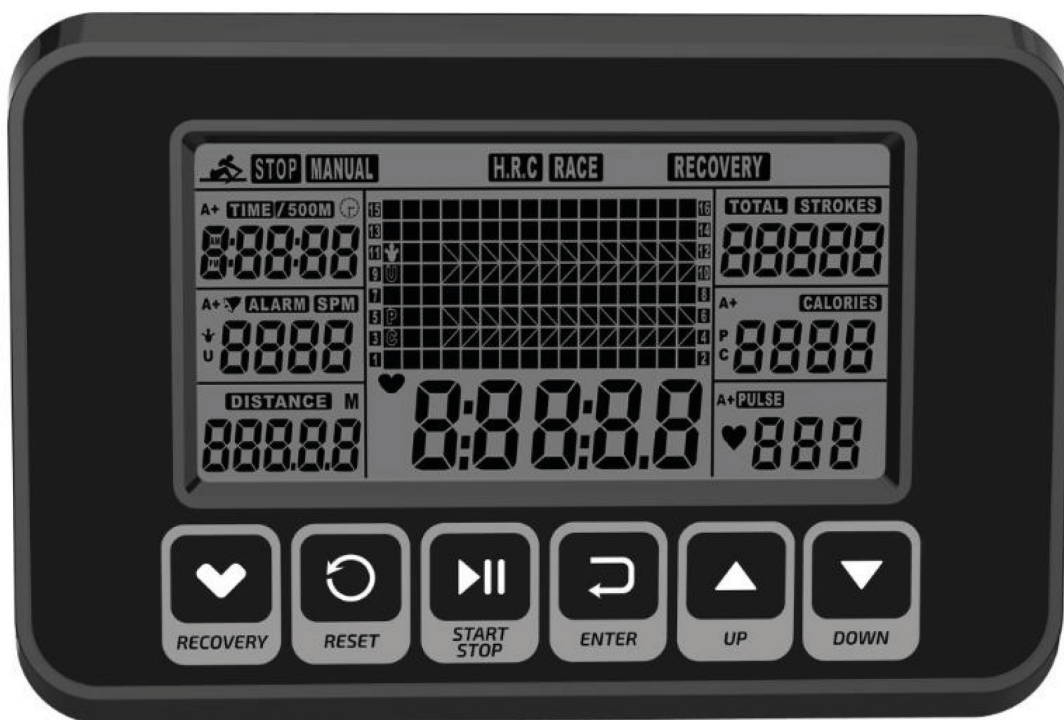

<b>TIME</b>	The current incline level is displayed here.
<b>TIME/500M</b>	Your covered or remaining distance is displayed here.
<b>SPM</b>	The time you have already trained or the remaining time is displayed here. Hier wird Ihre zurückgelegte oder verbleibende Zeit angezeigt.
<b>DISTANCE</b>	The elapsed or remaining time is displayed here.
<b>STROKES</b>	Adjust the stroke goal with the UP/DOWN buttons (10 to 9990 Strokes), in 10 Strokes increments
<b>TOTAL STROKES</b>	Counts your total strokes from 0 to 9999 Strokes

<b>CALORIES</b>	Adjust the calories burnt goal with the UP/DOWN buttons (110 to 9990 Cal), in 10 Cal increments
<b>HRC/PULSE</b>	Shows your heart rate. In manual mode adjust the Heart rate goal with the UP/DOWN buttons (30 to 240 BPM), in 1 BPM (Beats per Minute) increments. HRC is shown in the upper section of the display. The computer displays the Heart Rate during the training session. When the goal is reached, PULSE is displayed and a signal is heard until you change the program or take off your heart rate sensor. Heart Rate monitoring is possible only with a 5kHz Heart Rate Sensor.
<b>CALENDAR</b>	The display shows the Year, Month and Day while in sleep mode.
<b>TEMPERATURE</b>	The display shows the room temperature while in sleep mode.
<b>CLOCK</b>	The display shows the time while in sleep mode.

### 3.2 Button Functions

<b>UP/DOWN</b>	By pressing the COOL DOWN button during a training session the cool down program will start directly. The speed of the belt will slowly decrease to a full stand still within 2 or 3 minutes.
<b>ENTER</b>	With this button you can choose between the different programs.
<b>START/STOP</b>	With this button you can enter a program or confirm the selected value.
<b>RESET</b>	With this button you can change the fan speeds: 1x low 2x high 3x off
<b>RECOVERY</b>	With this button you can choose the display values between speed in km/h and pace in min/km.

### 3.3 Turning On and Setting Up the Machine

1. Insert two AA batteries (contained in the scope of delivery) into the console.

A signal sounds for two seconds (Fig. 1). The computer enters the CLOCK & CALENDER MODE (Fig. 2).

CLOCK is displayed.

2. Press UP to adjust to the hours. Confirm by pressing ENTER. Press UP to adjust the minutes. Confirm by pressing ENTER.
3. Use the same procedure to adjust the year (in the Strokes display), month (in the Calorie display) and day (in the Pulse display) using the UP/DOWN buttons to adjust the values and the ENTER button to confirm.

Afterwards ALARM is displayed.

4. To skip setting an alarm press the ENTER button.
5. To set an alarm press UP.

An arrow is now shown next to ALARM.

6. Press ENTER.

The CLOCK display is now active.

7. Set an alarm time using the UP/DOWN buttons. Confirm by pressing ENTER.

The computer switches to the SPORT display (Fig. 3).

MANUAL and RACE will blink when the SPORT display is active.

8. Choose MANUAL or RACE with the UP/DOWN buttons. Confirm using the ENTER button.



Fig. 1



Fig. 2

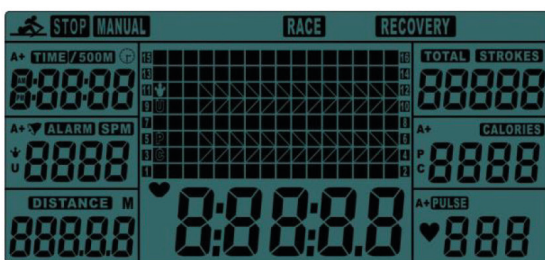

Fig. 3

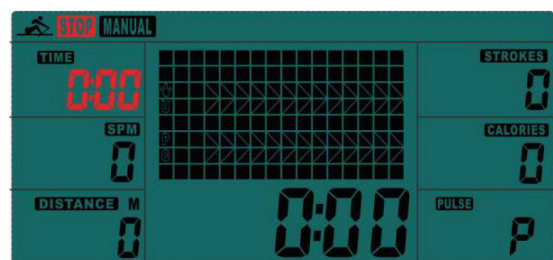

Fig. 4

## 3.4 Programmes

### 3.4.1 MANUAL

#### WARNING

Your training equipment is not a medical device. The heart rate measurement of this equipment may be inaccurate. Various factors can affect the accuracy of the heart rate measurement. The heart rate measurement serves only as a training aid.

#### Quick-Start:

1. Press START to start the training.

*The computer counts the value of your workout.*

2. To stop the training, press STOP.

#### Countdown:

1. Select MANUAL.

*The value for TIME flashes.*

2. Press UP to set the value of TIME to countdown. Confirm with the ENTER button.

#### NOTICE

If you do not want to set the value of TIME to countdown, press ENTER to go to the next function. You can set the values for DISTANCE, STROKES, CALORIES, or PULSE. You can only set the value for one function to countdown.

**For example:** if you have set the target value for TIME, then DISTANCE can't be set

3. Press START button to start.

*The STOP icon will disappear.*

*When the function you have selected counts down to zero or you press STOP button, the computer will stop and display the average value.*

### 3.4.2 RACE

1. Select the RACE mode.

*L1 will flash. The TIME/500M will display 8:00*

2. Press the UP/DOWN buttons to select L1 - L15. Press ENTER to confirm. Then, you can set the distance of the race (500M to 10000M) while the value of DISTANCE is blinking.
3. Press ENTER and the picture of the race will display on the screen.

The TIME/500M of the programs are as follows:

L1	L2	L3	L4	L5	L6	L7	L8	L9	L10	L11	L12	L13	L14	L15
8:00	7:30	7:00	6:30	6:00	5:30	5:00	4:30	4:00	3:30	3:00	2:30	2:00	1:30	1:00

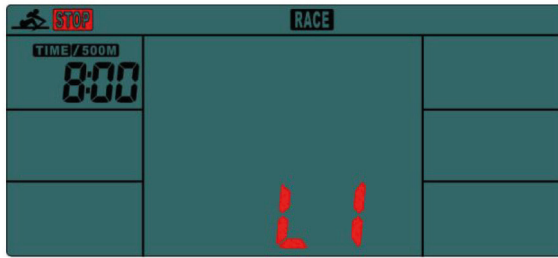

Fig. 5

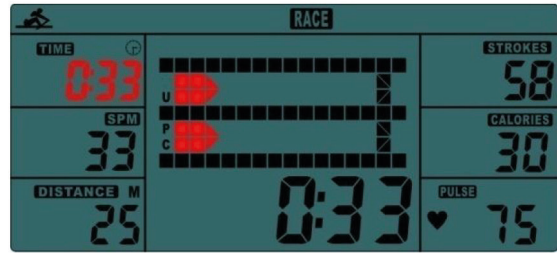

Fig. 6

4. Press START to start the race.

*STOP will disappear. USER(U) and PC will display in the matrix (Fig.6).*

*The computer will stop when either user or computer has reached the race distance that was set. The display shows "PC WIN" or "USER WIN" (Fig.7).*

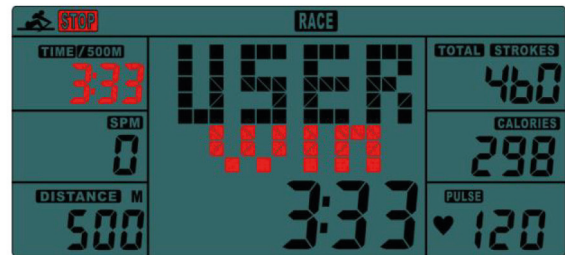

Fig. 7

5. When the race is over, you can press START to start a race once again.
6. Press RESET to leave the RACE screen.

### 3.4.3 RECOVERY

1. The computer only works with a 5.3 kHz chest strap heart rate monitor. After exercising for a period of time, keep wearing chest strap monitor and press "RECOVERY" button.

*All function displays will stop except "TIME" and starts counting down from 00:60 to 00:00.*

*The screen will display your heart rate recovery status with the F1, F2....to F6.*

*F1 is outstanding. F6 is poor. User may keep exercising to improve the heart rate recovery status.*

2. Press the RECOVERY button again to return to the main display.

## 3.5 Further Information

### ALARM

Alarm only works while the computer is in sleep mode. Alarm will not sound during training. Press and hold RESET to go to clock screen to set up ALARM.

### SLEEP MODE

The computer will go into sleep mode after about 4 minutes of inactivity.

### BATTERY

This meter uses 2x AA batteries, which are included. Changing the batteries will reset all values. If there is a problem with the display, try changing the batteries first. Change both of the batteries when replacing them. Do not mix battery types. Do not mix old and new batteries. Dispose of old batteries according to your regional guidelines.

## 3.6 Notes on correct rowing

### Body moves towards the handle

#### Wrong

At the end of the movement, the body will be pulled forwards towards the handles instead the handles to the body.

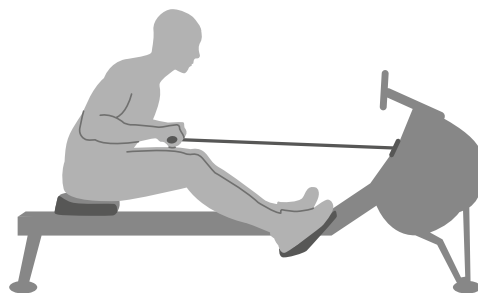

#### Right

At the end of the movement, the user slightly leans back, holds the legs down, keeps the upper body straight and pulls the handle to the body.

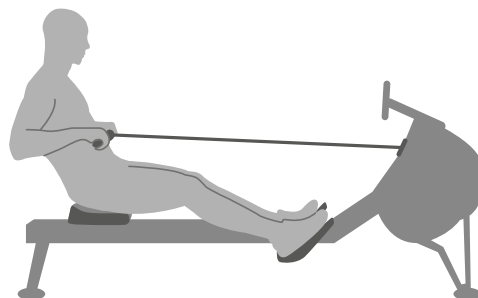

### Straddled elbows

#### Wrong

The user's elbows are straddled from the body at the end of the movement and the handle is at the height of the breast.

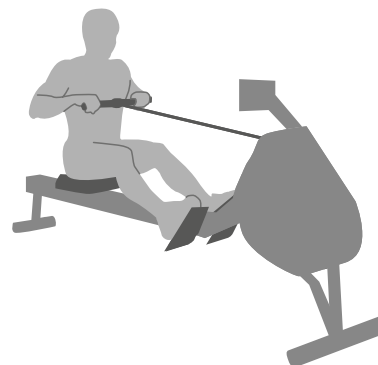

**Right**

Pull the handle to the body with straight wrists and the elbows close to the body. The elbows are brought behind the head while the handle is pulled to your waist.

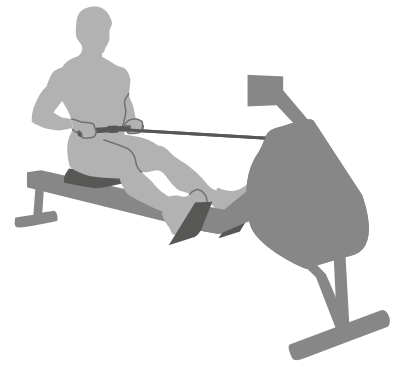

**Do not completely extend**

**Wrong**

At the end of the movement, the user completely stretches the leg and knee.

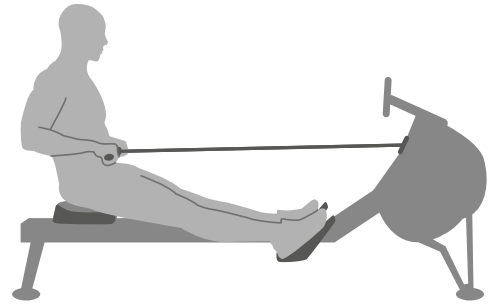

**Right**

Keep your knee slightly bent at all times even at the end of the movement instead of stretching it completely.

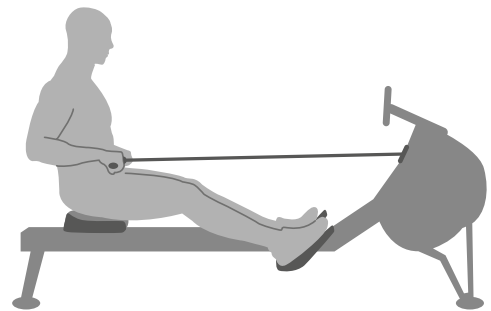

**Leaning too far forward**

**Wrong**

The body is bent too far forward. The shins are no longer vertical. The head and shoulders are facing the feet. The body is therefore in a weak position to execute the movement.

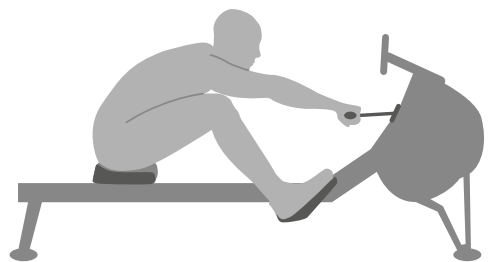

**Right**

The shins are vertical. The body is pressed against the legs, the arms are completely stretched out in front and the body is slight bent forward. This position should be pleasant.

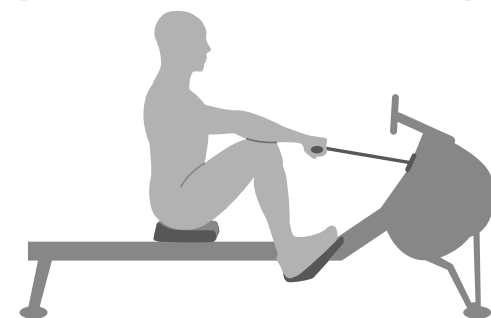



## Rowing with bent arms

### Wrong

The user begins the movement with the arms instead of first pressing with the legs.

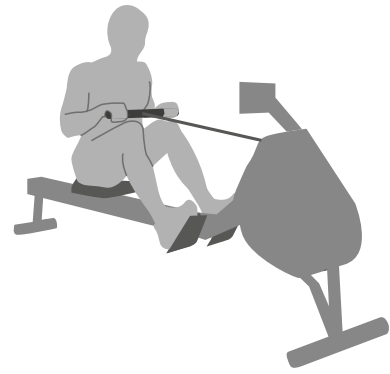

### Right

The user begins by stretching out the legs, relaxing the back and stretching the arms.

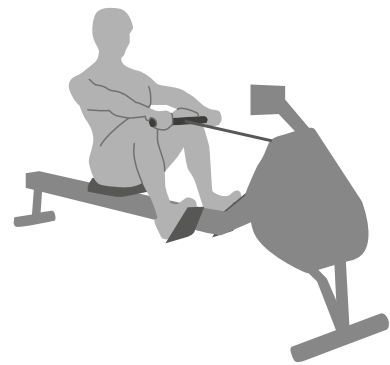

## Bent wrists

### Wrong

The user bends the wrists during the movement.

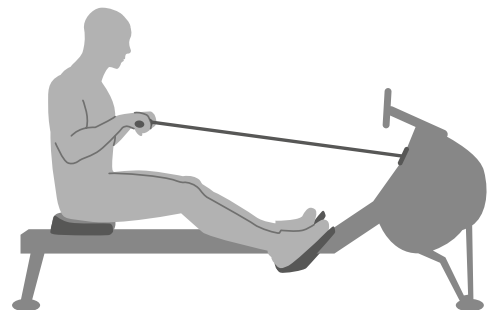

### Right

Always execute the rowing movement with straight wrists.

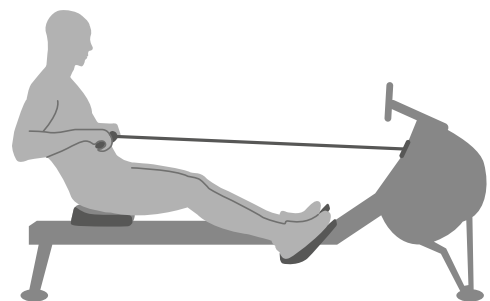

## 4.1 General Instructions

### ⚠ WARNING

- + The storage location should be chosen so that improper use by third parties or children can be prevented.
- + If your equipment does not have transportation wheels, the equipment must be disassembled before transportation.

### ▶ ATTENTION

- + Make sure that the equipment is protected from moisture, dust and dirt in the selected storage location. The storage location should be dry and well ventilated and have a constant ambient temperature between 5°C and 45°C.

## 4.2 Transportation Wheels

### ▶ ATTENTION

If you want to transport your equipment over particularly sensitive and soft floor coverings, such as parquet, planks or laminate, lay out the transport route with cardboard or similar to avoid possible floor damage.

1. Stand behind the equipment and lift it until the weight is transferred to the transportation wheels. After that, you easily can move the equipment to a new position. For long transport distances the equipment should be disassembled and safely packed.
2. Select the new location by following the instructions in the section 1.3 of this manual.

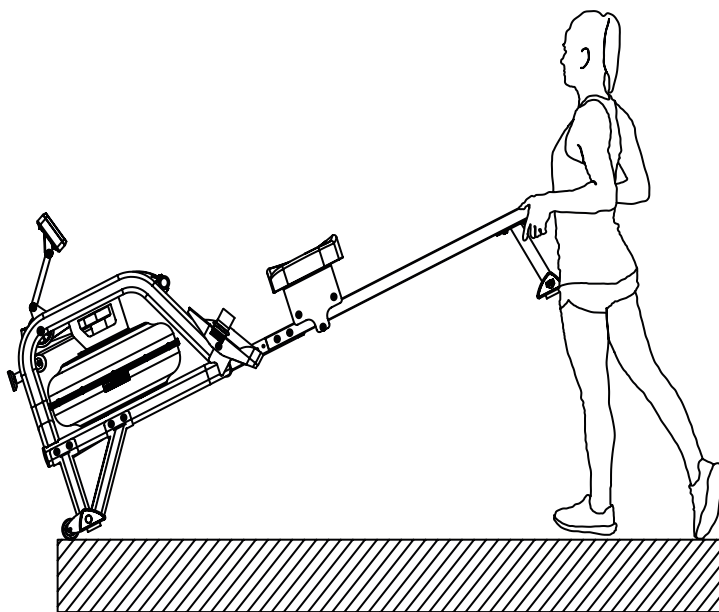

## 4.3 Storage

### ⚠ CAUTION

- + Move with caution when you raise the rower up, as you can hit your head with the Rear Stand (4).
- + Move the Seat (36) to the front of the Slide Rail (3) first or it will slide down when raising the rower up.

When not in use, you can save space by storing the rower vertically. Lift the Rear Stand (4) to raise the rower to vertical position. If the rower will not be used for more than a month, empty the tank before storing.

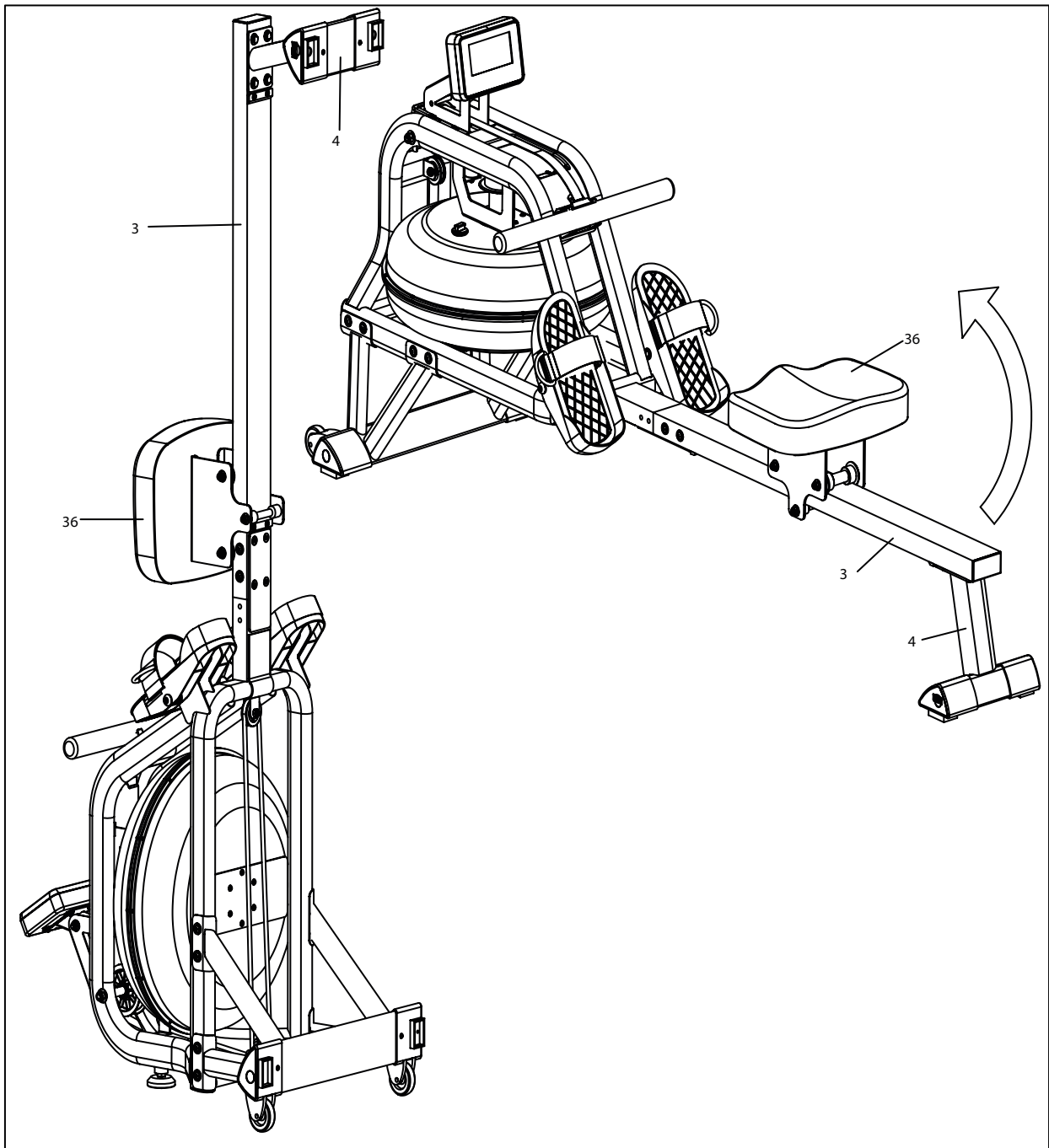

## 5.1 General Instructions



### WARNING

- + Do not make any improper changes to the equipment.



### CAUTION

- + Damaged or worn components may affect your safety and the life of the equipment. Therefore, immediately replace damaged or worn components. In such a case, contact the contract partner. The equipment must not be used until it has been repaired. If necessary, use only original spare parts.

### ATTENTION

- + In addition to the instructions and recommendations for maintenance and care given here, additional service and/or repair work may be necessary; this must only be carried out by authorised service technicians.

## 5.2 Faults and Fault Diagnosis

The equipment undergoes regular quality controls during production. Nevertheless, faults or malfunctions may occur. Frequently, individual parts are responsible for these disturbances, an exchange is usually sufficient. Please refer to the following overview for the most common errors and how to correct them. If the equipment still does not function properly, contact your contract partner.

Fault	Cause	Solution
Display is blank/is not working	Batteries empty or loose cable connection	Replace batteries or check cable connections
Creaking noises	Screw connections loosened or too tight	Check screw connections
Grinding noises on the guide rail	Guide rail or rollers dirty or guide rail dry	Clean the guide rail and then lubricate it with a suitable lubricant
No pulse display	<ul style="list-style-type: none"> <li>+ Sources of interference in the room</li> <li>+ unsuitable chest strap</li> <li>+ Wrong position of chest strap</li> <li>+ Chest strap defective or battery empty</li> <li>+ Pulse display defective</li> </ul>	<ul style="list-style-type: none"> <li>+ Eliminate sources of interference (e.g. mobile phone, WLAN, lawn mower and vacuum cleaner robot, etc. ...)</li> <li>+ Use a suitable chest strap (see RECOMMENDED ACCESSORIES).</li> <li>+ Reposition chest strap and/or moisten electrodes</li> <li>+ Changing batteries</li> </ul>

## 5.3 Maintenance and Inspection Calendar

To avoid damage from body sweat, the equipment must be cleaned with a damp towel (no solvents!) after each training session.

The following routine tasks must be performed at the specified intervals:

Part	Weekly	Monthly	Quarterly	Half-yearly
Display console	C	I		
Lubrication of slide rail and moving parts		I		
Plastic covers	C	I		
Screws and cable connections		I		
Water colour/Chlorine				I
Legend: C = clean; I = inspect				

The stability and the quality of this rowing machine can only be maintained, when the rowing machine is regularly checked with respect to potential damages or signs of wear. Please pay a special attention to the following aspects:

- + It is the responsibility of the user/owner alone to perform regular maintenance.
- + Sit on the seat and pull the handle to ensure that the resistance system produces sufficient resistance. Also make sure that the seat slides smoothly and stably on the rail.
- + To lubricate the rail, apply a little lubricating oil to a paper towel or clean cloth. Spread a thin layer of the oil evenly along the rail where the rollers run. Then remove excess oil.
- + Clean the rollers on the rail with an absorbent, lint-free cloth.
- + Clean the water in the tank regularly. The water must be regularly refreshed by adding a chlorine tablet (every four to six months). Only use chlorine tablets for rowing machines. The use of other products will make the warranty invalid and cause damage to the machine.

## 6 DISPOSAL

At the end of its operational life, this equipment cannot be disposed of in normal household waste. Instead, it must be disposed of via an electricals recycling centre. Further information can be obtained from your local authority's recycling service.



The materials can be recycled as per their symbols. Through the reuse, recycling of materials or other forms of recovery of old equipment, you make an important contribution to the protection of the environment.

Pb = Battery contains more than 0.004 percent by weight of lead.

Cd = Battery contains more than 0.002 percent by weight of cadmium.

Hg = Battery contains more than 0.0005 percent by weight of mercury.

To make your training experience even more efficient and pleasant, we recommend that you add suiting accessories to your fitness equipment. This could be a floor mat, for example, which makes your fitness equipment stand more securely and also protects the floor from falling sweat, but it could also be additional handrails on some treadmills or silicone spray to keep moving parts in good shape.

If you have purchased a fitness machine with pulse training and want to train your heart rate, we strongly recommend that you use a compatible chest strap, as this ensures optimum transmission of the heart rate. You may want to buy additional grips or weights for multi gyms.

Our range of accessories offers the highest quality and makes training even better. If you would like to find out more about compatible accessories, please go to the detail page of the product in our webshop (the easiest way is to enter the article number in the search field above) and go to the recommended accessories on this page. Alternatively, you can use the QR code provided. Of course, you can also contact our customer service: by telephone, e-mail, in one of our branches or via our social media channels. We will be happy to advise you!



floor mat



chest strap



chest strap contact gel



towels



silicone spray

## 8.1 Serial Number and Model Name

In order to provide you with the best possible service, please have the model name, article number, serial number, exploded drawing and parts list ready. The corresponding contact options can be found in chapter 10 of this operating manual.

**NOTICE**

The serial number of your equipment is unique. It's located on a white sticker. The exact position of this sticker is shown in the following illustration.



Enter the serial number in the appropriate field.

**Serial number:**

**Brand / Category:**

**Model Name:**

**Article Number:**

## 8.2 Parts List

No.	Name	Specification	Qty.
01	Main frame		1
02	Front stabilizer		1
03	Slide Rail	SPHC,T=1.5	1
04	Rear Stabilizer		1
05	Support for Computer		1
06	Support Plate		1
07	Tank Plate		1
08	Plate for Bushing	SPHC,T=3.0	1
09	Handlebar		1
10	Seat Carriage	SPHC,T=4.0	2
11	Impeller	Yellow	1
12	Upper Tank	PC	1
13	Lower Tank	PC	1
14	Mesh Belt Wheel		1
15	Decorate Cover	HIPS, black	1
16	Belt Wheel	POM, black	1
17	Handlebar Seat	HIPS, black	1
18	Roller	POM, black	3
19	Roller Spacer		3
20	Guide Roller	POM, black	1
21	Magnet Seat	POM, black	1
22	Bungee Pulley with 608 bearing	POM, black	4
23	Left Pedal	PP, black	1
24	Right Pedal	PP, black	1
25	Left End Cap		1
26	Right End Cap		1
27L/R	Adjustable End Cap		2
28	Rail End Cap	PP, black	1
29	Oval Plug	PP, black	2
30	Rubber Sealing Ring	Rubber, black	1
31	Impeller Shaft Seal	Rubber, black	1
32	Round Plug	PP, black	1
33	Fill Plug	Rubber, black	1



34	O Shape Ring	Rubber, black	1
35	Limit Pad	Rubber, black	2
36	Seat	PU, black	1
37	Pedal Strap	PP, black	2
38	Strap	Nylon, black	1
39	Bungee Cord	Nylon, black	1
40	Plastic Washer	POM, black	2
41	One Way Bearing HFL2016	HFL2026	1
42	Bearing 6000ZZ	6000ZZ	4
43	Bearing 608ZZ	608ZZ	6
44	Bushing		2
45	Pin 6x40	Ø6.0*40	1
46	Computer		1
47	Sensor Wire		1
48	Sensor Holder	Nylon, black	1
49	Magnet	Ø10*5	1
50	Spacer for Mesh Belt Wheel	Ø16* Ø10.2*69	2
51	Short Spacer	Ø12.7* Ø8.2*13	6
52	Screw M10x185	M10*185	1
53	Washer	OD25*ID10.5*2.0	2
54	Screw M8x30	M8*30	4
55	Screw M6x15	M6*15	10
56	Nylon Lock Nut M8	M8	9
57	Nylon Lock Nut M10	M10	2
58	Flat Screw M8x55	M8*15	12
59	Screw M10x55	M10*55	1
60	Screw M8x15	M8*15	20
61	Screw M3x20	M3*20	12
62	Nylon Lock Nut M3	M3	12
63	Screw M8x65	M8*65	1
64	Screw M5x12	M5*12	4
65	Screw M8x125	M8*125	2
65	Screw	M8*125	3
66	Hex Head Screw M8x15	M8*15	4
67	Flat Cross Screw M6x10	M6*10	4
68	Cross Screw M4x12	M4*12	3

69	Nylon Lock Nut M4	M4	1
70	Screw M12x125	M12*125	2
71	Flat Washer	OD20*ID8.5*1.5	31
72	Screw	ST4.2*16	2
73	Knob		1
74	Allen Key	S5	1
75	Allen Wrench	S13-S17	1
76	Pumping Siphon		1
77	Funnel		1
78	Lower Tank Plate	SPHC,T=3.0	1
79	Plastic Bushing	Ø27* Ø8.2*10	4
80	Sensor Bracket L	SPHC,T=2.0	1
81	Sensor Bracket R	SPHC,T=2.0	1
82	Screw M8x75	M8*75	1
83	Sealing Ring for Upper Tank	Rubber, black	1
84	Stainless Washer M3	M3	24
85	Spacer for Belt Wheel		1
86	Steel Sleeve		1
87	Cross Screw M6x15	M6*15	2
88	Hex Nut M10	M10	2
89	Hook Pad	PP,W25,black	1
90	Screw	M8*60	2
91	Stainless Washer	Φ35*Φ20.2*1.0	1
92	Aluminium Clasp		1
93	Lower pad	50*25*T2.0	2
94	Spacer for roller	OD15*ID8.0*4.1	8
95	Spacer for Gider Roller	Φ14*1.5*19, ABS+PC, black	1
96	Foam Spacer	Φ98*Φ28*20	1
97	Taper Roller Bearing	HK2010	2
98	Upper pad	25*25*T2.0	4
99	Bolt	M8*130	1
100	Nut	M6	2
101	Adjust bolt	M6*30	2
102	PC board		1
103	Ring		1

# 8.3 Exploded Drawing

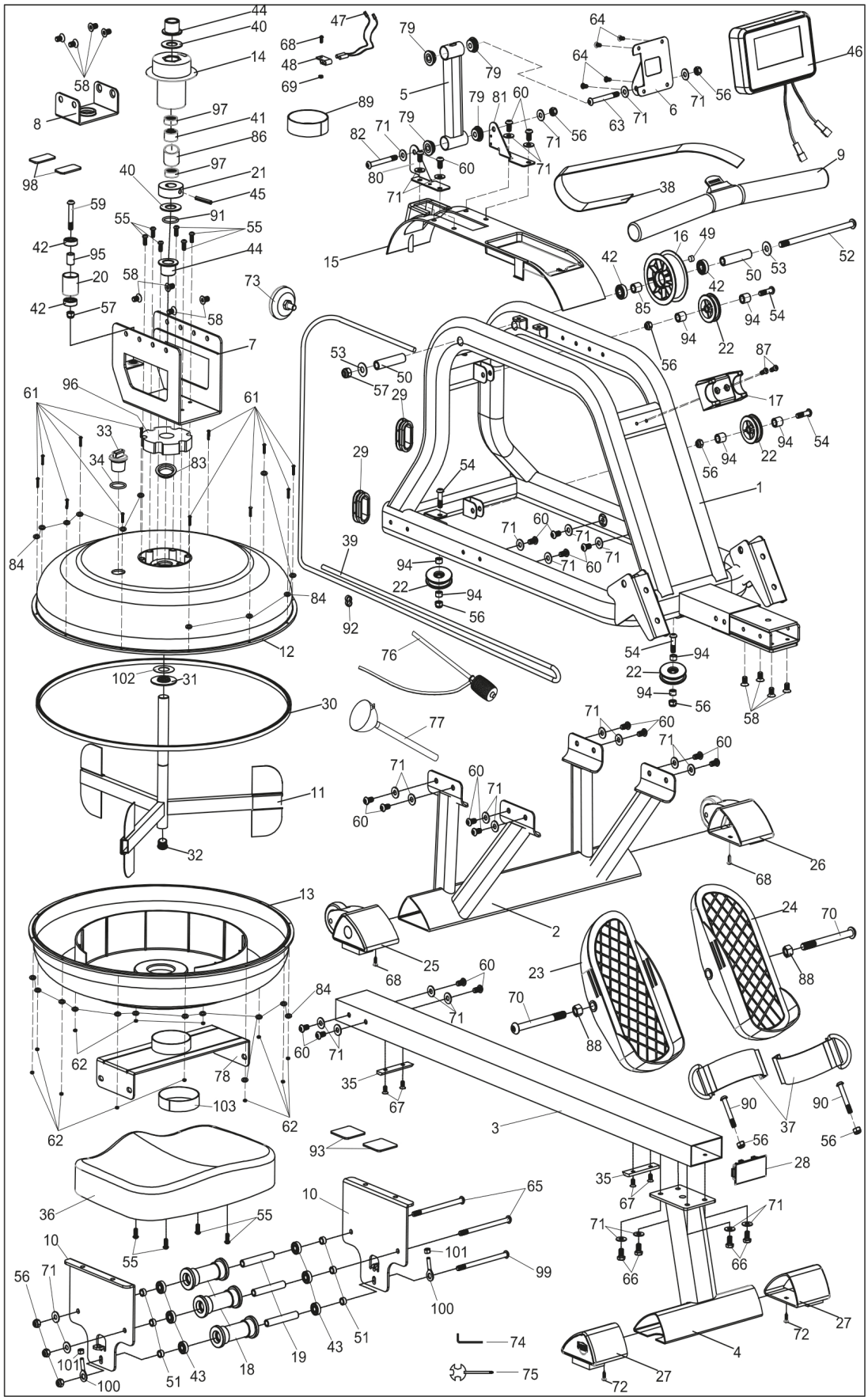

Training equipment from Taurus® is subject to strict quality control. However, if a fitness equipment purchased from us does not work perfectly, we take it very seriously and ask you to contact our customer service as indicated. We are happy to help you by phone via our service hotline.

### **Error Descriptions**

Your fitness equipment is developed for long-term, high-quality training. However, should a problem arise, please first read the operating instructions. For further assistance, please contact your contract partner or call our service hotline. To ensure your problem is solved as quickly as possible, please describe the defect as exactly as possible.

In addition to the statutory warranty, we provide a warranty for every fitness equipment purchased from us according to the following provisions.

**Your statutory rights are not affected.**

### **Warrantee**

The warrantee is the first/original buyer and/or any person who received a newly purchased product as a gift from the original buyer.

### **Warranty period**

The warranty periods, shown on our web shop, begin on delivery of the fitness equipment. The respective warranty periods for your equipment can be found on its product website.

### **Repair Costs**

According to our choice, there will either be a repair, a replacement of individual damaged parts or a complete replacement. Spare parts, that have to be mounted while assembling the equipment, have to be replaced by the warrantee personally and are not a part of repair. After the expiration of the warranty period for repair costs, a pure parts warranty applies, which does not include the repair, installation and delivery costs.

### **The terms of use are defined as follows:**

- + Home use: solely for private use in private households up to 3 hours per day
- + Semi-professional use: up to 6 hours per day (e. g. rehabilitation centres, hotels, clubs, company gyms)
- + Professional use: more than 6 hours per day (e. g. commercial gyms)

### **Warranty Service**

Within the warranty period, equipment which develops faults as a result of material or manufacturing defects, will be repaired or replaced at our discretion. Ownership of equipment or parts of equipment which have been replaced is transferred to us. The warranty period is not extended nor does a new warranty period begin following repair or replacement under the warranty.

## **Warranty Conditions**

For the warranty to be valid, the following steps must be taken:

Please contact our customer service by email or phone. If the product under warranty has to be sent in for repair, the seller bears costs. After expiry of the warranty, the buyer bears the costs of transport and insurance. If the fault is covered by our warranty, you will receive a new or repaired equipment in return.

### **Warranty claims are invalid in case of damage resulting from:**

- + misuse or improper handling
- + environmental influences (moisture, heat, electrical surge, dust, etc.)
- + failure to follow the current safety measures for the equipment
- + failure to follow the operating instructions
- + use of force (e. g. hitting, kicking, falling)
- + interventions which were not carried out by one of our authorized service centres
- + unauthorised repair attempts

### **Proof of Purchase and Serial Number**

Please make sure that you are able to provide the appropriate receipt when claiming on your warranty. So that we can clearly identify the model of your equipment, and for the purposes of our quality control, you will need to give the serial number of your equipment, when contacting the service team. Where possible please have your serial number and your customer number ready when you call our service hotline. It will help us to deal with your request swiftly.

If you cannot find the serial number on your fitness equipment, our service team is at your disposal to offer further information.

### **Service outside of the Warranty Period**

We are also happy to issue an individual cost estimate if there is a problem with your fitness equipment after the warranty has expired, or in cases which do not fall under the terms of the warranty, e. g. normal wear and tear. Please contact our customer service team to find a quick and cost-effective solution to your problem. In such a case you will be responsible for the delivery costs.

### **Communication**

Many problems can be solved just by speaking to us as your specialist supplier. We know how important it is to you as a user of the fitness equipment to have problems solved quickly and simply, so you can enjoy working out with minimal interruption. For that reason, we also want to resolve your queries quickly and in a straightforward manner. Thus, please always keep your customer number and the serial number of the faulty equipment handy.

DE	DK	FR
<p><b>TECHNICAL SUPPORT</b></p> <p>☎ +49 4621 4210-900                      📠 +49 4621 4210-698                      ✉ technik@sport-tiedje.de</p> <p>🕒 Mo - Fr 08:00 - 18:00                      Sa 09:00 - 18:00</p> <p><b>SERVICE</b></p> <p>☎ 0800 20 20277                      (Freecall)</p> <p>✉ info@sport-tiedje.de</p> <p>🕒 Mo - Fr 08:00 - 21:00                      Sa 09:00 - 21:00                      So 10:00 - 18:00</p>	<p><b>TECHNICAL SUPPORT &amp; SERVICE</b></p> <p>☎ 80 90 16 50                      +49 4621 4210-945                      ✉ info@fitshop.dk</p> <p>🕒 Mo - Fr 08:00 - 18:00                      Sa 09:00 - 18:00</p>	<p><b>TECHNICAL SUPPORT &amp; SERVICE</b></p> <p>☎ +33 (0) 172 770033                      +49 4621 4210-933                      ✉ service-france@fitshop.fr</p> <p>🕒 Mo - Fr 08:00 - 18:00                      Sa 09:00 - 18:00</p>
	PL	BE
	<p><b>TECHNICAL SUPPORT &amp; SERVICE</b></p> <p>☎ 22 307 43 21                      +49 4621 42 10-948                      ✉ info@fitshop.pl</p> <p>🕒 Mo - Fr 08:00 - 18:00                      Sa 09:00 - 18:00</p>	<p><b>TECHNICAL SUPPORT &amp; SERVICE</b></p> <p>☎ 02 732 46 77                      +49 4621 42 10-932                      ✉ info@fitshop.be</p> <p>🕒 Mo - Fr 08:00 - 18:00                      Sa 09:00 - 18:00</p>

UK	NL	INT
<p><b>TECHNICAL SUPPORT</b></p> <p>☎ +44 141 876 3986                      ✉ support@powerhousefitness.co.uk</p> <p><b>SERVICE</b></p> <p>☎ +44 141 876 3972                      🕒 Mo - Fr 9am - 5pm</p>	<p><b>TECHNICAL SUPPORT &amp; SERVICE</b></p> <p>☎ +31 172 619961                      ✉ info@fitshop.nl</p> <p>🕒 Ma - Do 09:00 - 17:00                      Vr 09:00 - 21:00                      Za 10:00 - 17:00</p>	<p><b>TECHNICAL SUPPORT &amp; SERVICE</b></p> <p>☎ +49 4621 4210-944                      ✉ service-int@sport-tiedje.de</p> <p>🕒 Mo - Fr 8am - 6pm                      Sat 9am - 6pm</p>
	AT	CH
	<p><b>TECHNICAL SUPPORT &amp; SERVICE</b></p> <p>☎ 0800 20 20277                      (Freecall)                      +49 4621 42 10-0                      ✉ info@sport-tiedje.at</p> <p>🕒 Mo - Fr 08:00 - 18:00                      Sa 09:00 - 18:00</p>	<p><b>TECHNICAL SUPPORT &amp; SERVICE</b></p> <p>☎ 0800 202 027                      +49 4621 42 10-0                      ✉ info@sport-tiedje.ch</p> <p>🕒 Mo - Fr 08:00 - 18:00                      Sa 09:00 - 18:00</p>

Please find a detailed overview including address and opening hours for all stores of the Sport-Tiedje Group in Germany and abroad on the following website:

[www.sport-tiedje.com/en/stores](http://www.sport-tiedje.com/en/stores)

# WE LIVE FITNESS

## WEBSHOP AND SOCIAL MEDIA

Sport-Tiedje is Europe's largest specialist store for home fitness equipment with currently 80 stores and one of the world's most renowned online mail order companies for fitness equipment. Private customers order via the 25 web shops in the respective national language or have their desired equipment assembled on site. In addition, the company supplies fitness studios, hotels, sports clubs, companies and physio practices with professional equipment for endurance and strength training.

Sport-Tiedje offers a wide range of fitness equipment from renowned manufacturers, high-quality in-house developments and comprehensive services, such as a build-up service and sports scientific advice before and after the purchase. The company employs numerous sports scientists, fitness trainers and competitive athletes.

Visit us also on our social media platforms or our blog!

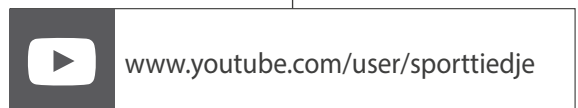
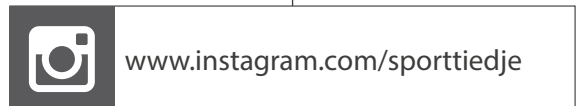
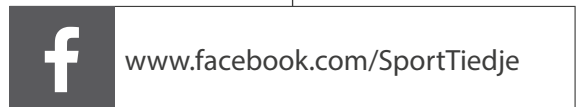



DARWIN RM 50