

# FORCE USA

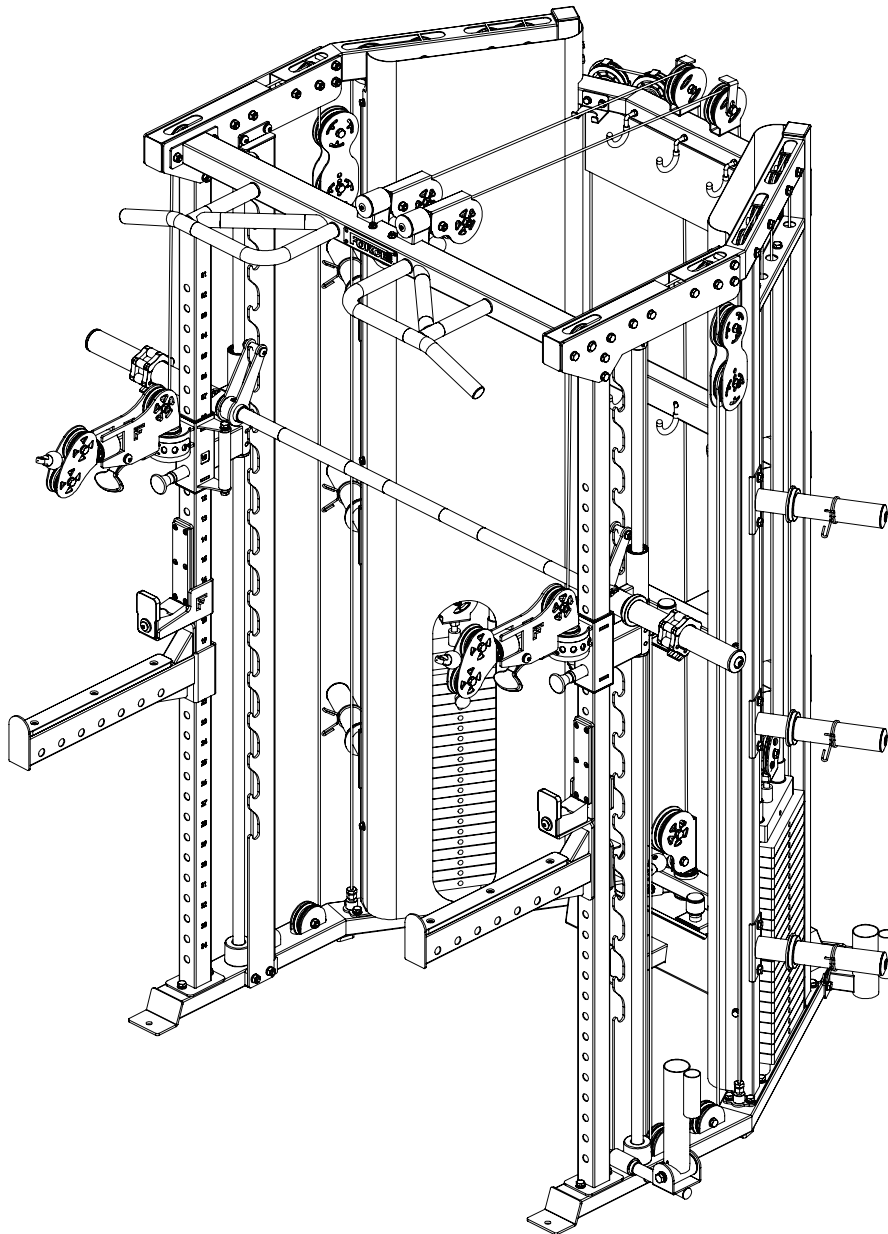

USER MANUAL | **F-C10**





# **THANK YOU FOR YOUR PURCHASE**

**For the most up to date info about using  
your equipment and our latest support  
videos, please visit:**

**[www.forceusa.com](http://www.forceusa.com)**







# TRAINING APP

Download now and get access to 400+ exercise tutorials, absolutely free!



## DOWNLOAD THE APP



### STAY FOCUSED

Enjoy a low-friction interface designed to keep you focused on your next set.

### NEW WORKOUT PLANS

Loaded with a growing library of unique workouts. Hundreds of movement tutorials designed by our expert panel of coaches.

### REWARD YOUR SUCCESS

See your results build after every session with the pyramid progress tracker. Feel the support and share your progress with family and friends.

### HARDER IS GOOD SMARTER IS BETTER

The Force USA Training App offers customized workout plans so that you can get the same results in half the time.

Learn more at [app.forceusa.com](http://app.forceusa.com)



# BEFORE YOU START



**Read all instructions in this manual before assembling or using this equipment**



**Only tighten nuts and bolts loosely until all equipment is assembled. Once the equipment is fully assembled, tighten from the bottom up, working evenly around the unit.**

- Remove all parts from the packaging and count each component separately to ensure everything is provided correctly, noting that some items may be pre-assembled
- Follow the instructions and refer to both the individual assembly pages and the exploded views of the equipment whenever possible
- The owner is responsible for ensuring that all users of this unit have read the user manual and understand the safety precautions
- Descriptions of left and right refer to the perspective of standing in front, facing the equipment.
- Place all parts in a cleared area and remove the packing materials. Do not dispose of the packing materials until all assembly steps are completed
- It is recommended to keep these instructions

Although current at the time of this printing, specifications for this model may have changed in our continuing effort for improvement. Force USA reserves the right to modify and improve the specifications of its products without prior notice.

# BEFORE YOU START CONTINUED

---

## SAFETY PRECAUTIONS

Every piece of Force USA equipment is built for maximum safety and meets or exceeds all applicable domestic and international standards. However, certain precautions must be taken when operating any piece of fitness equipment.

- It is highly recommended that two or more people are used for assembly
- Assemble equipment on a flat surface
- Consider placing a mat/mats under the equipment to protect your floor
- Ensure all parts are in working order prior to use
- Make sure all pivoting components are able to move freely
- Do not use or store the equipment outdoors or around water
- Do not over tighten any component with pivoting function
- Keep hair, fingers and clothing away from moving parts
- Only use attachments recommended by the manufacturer
- Never operate if parts are not functioning correctly
- Always stretch prior to using equipment
- Stop immediately if you experience any pain, dizziness or nausea
- Before starting any exercise program consult your doctor

## PREVENTATIVE MAINTENANCE

To ensure your equipment is operating at its peak, please follow the below preventative maintenance schedule performing all tasks upon initial assembly:





### Daily Maintenance

- Wipe down the equipment to remove any dust and sweat residue with a dry, non-abrasive cloth
- Inspect the unit for noisy, damaged or loose components



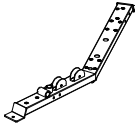
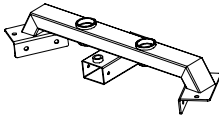
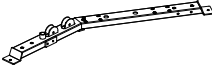

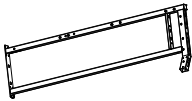
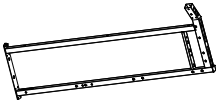
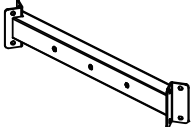
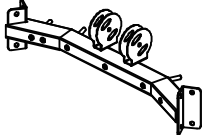
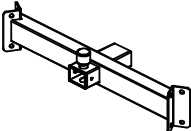
### Monthly Maintenance

- Thoroughly clean the equipment using a non abrasive cloth dampened with a mild, all purpose cleaner ensuring to thoroughly wipe down and dry the equipment afterwards
- Apply a 100% silicone lubrication (preferably spray) to guide rods, pulley sliders, weight plate carriages and any other moving parts where friction can occur including bearings (where applicable). Any other form of lubrication will void your warranty
- Check the tightness of all bolts, nuts and screws
- Check the cables for fraying or any signs of wear and ensure they are at the correct tension with a small amount of slack at resting position (where applicable)
- Inspect pulleys for any damage or cracks (where applicable)
- Knurling can be cleaned using a soft bristled brush to help remove any particles that may be nestled within the knurling
- Vacuum around the machine/equipment to prevent dust acclumulation



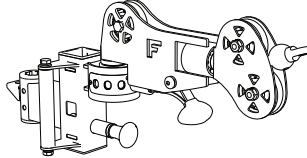
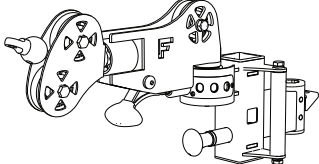

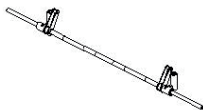
# PARTS & HARDWARE IDENTIFIER

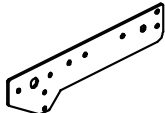
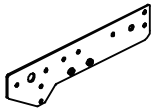
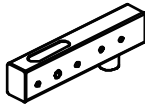
Key No.	Description	Quantity	Part Schematic Diagram
1	Base Frame - Right	1	
2	Base Linking Frame	1	
3	Base Frame - Left	1	
10	Barbell Storage Holder	1	
11	Upright Frame - Right	1	
12	Upright Frame - Left	1	
13	Upright Linking Frame - Middle	1	
14	Upright Linking Frame - Upper	1	
15	Upright Linking Frame - Lower	4	
16	Front Guide Tube	2	



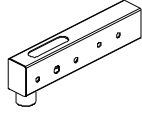
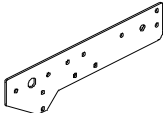
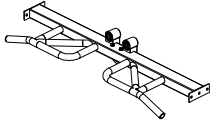
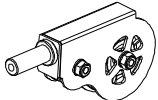
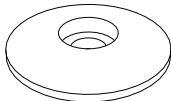

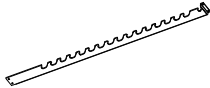

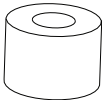
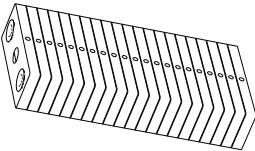

# PARTS & HARDWARE IDENTIFIER

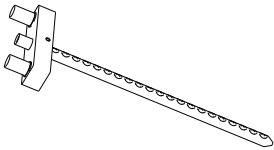
Key No.	Description	Quantity	Parts Schematic Diagram
17	Pulley Slider - Right	1	
18	Pulley Slider - Left	1	
19	Guide Rod - Smith Bar	2	
20	Rubber Bumper - Smith Bar	2	
21	Smith Bar	1	
22	Rubber Bumper - Pulley Slider	2	
23	Smith Bar Guide Rod Fixing Sleeve	2	
25	Upper Cover Plate - Outside	2	
26	Upper Cover Plate - Inside Right	1	
27	Front Upper Frame - Right	1	



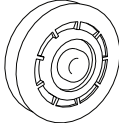

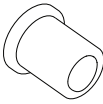
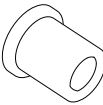
# PARTS & HARDWARE IDENTIFIER

Key No.	Description	Quantity	Part Schematic Diagram
28	Front Upper Frame - Left	1	
29	Upper Cover Plate - Inside Left	1	
31	Multi Grip Pull Up Bar	1	
32	Pulley Frame	4	
33	Pulley Frame Cover Plate	4	
36	Smith Bar Racking Frame - Right	1	
37	Smith Bar Racking Frame - Left	1	
40	Weight Stack Guide Rod	4	
41	Rubber Bumper - Weight Stack	4	
42	Weight Stack	2	

# PARTS & HARDWARE IDENTIFIER

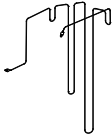
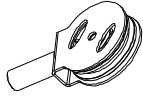

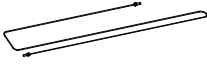
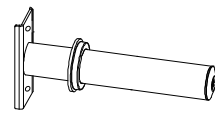
Key No.	Description	Quantity	Part Schematic Diagram
43	Selector Rod	2	
46	Weight Stack Pulley Frame	2	
47	Weight Stack Selector Pin	2	
48	Small Pulley	14	
49	Medium Pulley	10	
51	Floating Pulley Frame	2	
52	Large Pulley	2	
53	Small Bushing	22	
54	Large Bushing	4	
56	Pulley Cover	4	

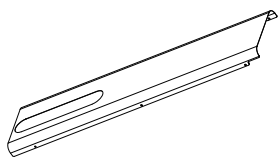
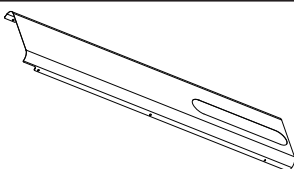
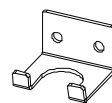
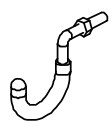
# PARTS & HARDWARE IDENTIFIER





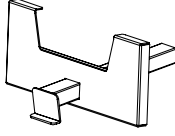

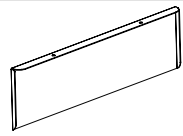
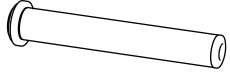
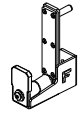
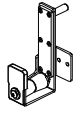
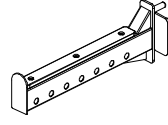
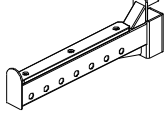
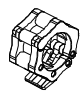
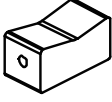

Key No.	Description	Quantity	Part Schematic Diagram
57	Front and Upper Pull Cable	2	
58	Rear Pull Cable Floating Pulley	2	
59	Pulley Cable Guide	2	
60	Smith Bar Cable	2	
61	Olympic Weight Plate Holder	6	
62	Rear Pull Cable	2	
63	Weight Stack Shield - Right	1	
64	Weight Stack Shield - Left	1	
68	Accessory Hook Plate	1	
69	Accessory Hook	7	

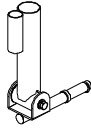

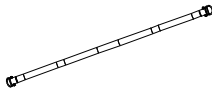
# PARTS & HARDWARE IDENTIFIER

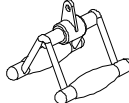

Key No.	Description	Quantity	Part Schematic Diagram
70	Low Row Footplate	1	
71	Dual Cable Connector	1	
72	Logo Board	1	
73	Smith Bar Olympic Sleeve	2	
74	J Hook - Left	1	
75	J Hook - Right	1	
76	Front Safety - Left	1	
77	Front Safety - Right	1	
78	Olympic Quick Lock Collar	2	
79	J-Hook Flat Shock Pad	2	

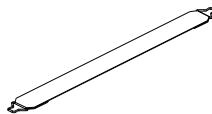
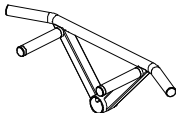
# PARTS & HARDWARE IDENTIFIER

Key No.	Description	Quantity	Part Schematic Diagram
80	Landmine/Core Trainer	1	
81	Single Stirrup - Nylon	2	
82	Connection Bar - Straight	1	
83	Extension Chain	4	
84	Ankle cuff	1	
85	Tricep Rope	1	
86	Close Grip Triangle	1	
87	Connection Bar - EZ Curl	1	
88	Bodyweight Assist Strap	1	
89	Core Trainer Handle	1	

# PARTS & HARDWARE IDENTIFIER

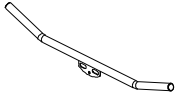
---

Key No.	Description	Quantity	Parts Schematic Diagram
90	Lat pulldown bar	1	
123	Olympic Spring Collar	6	

# PARTS & HARDWARE IDENTIFIER

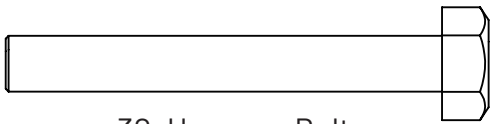

30. Hexagon Bolt  
M10X75 (x16)

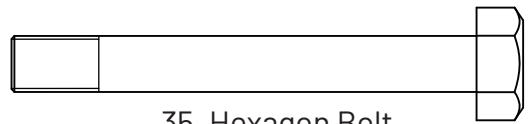

35. Hexagon Bolt  
M10X80 (x4)



38. Hexagon Bolt  
M10X110 (x4)

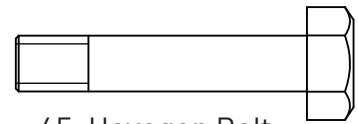

45. Hexagon Bolt  
M10X50 (x8)

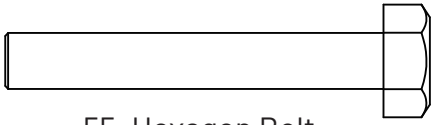

55. Hexagon Bolt  
M10X65 (x10)

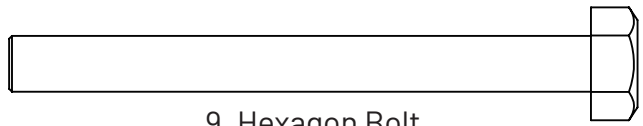

9. Hexagon Bolt  
M10X100 (x9)

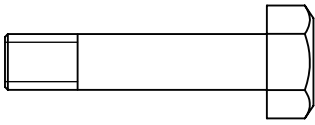

50. Hexagon Bolt  
M10X45 (x6)

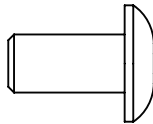

39. Button Head Screw  
M10X20 (x4)

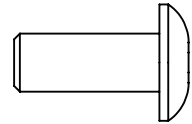

34. Button Head Screw  
M10X25 (x4)

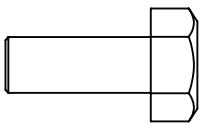

8. Hexagon Bolt  
M10X25 (x48)

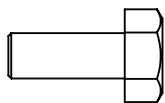

67. Hexagon Bolt  
M8X20 (x16)

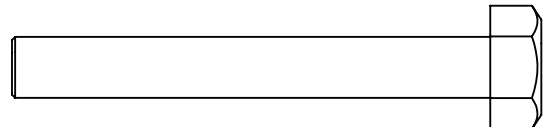

169. Hexagon Bolt  
M10X70 (x12)

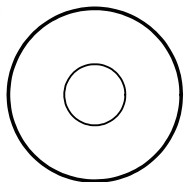

5. Big Flat Washer (x18)  
 $\phi 30^*$   $\phi 10$  5\*30



66. Spring Washer  $\phi 8$  (x12)

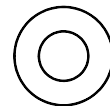

65. Flat Washer  $\phi 8$  (x16)

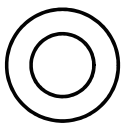

4. Flat Washer  $\phi 10$  (x 138)



171. Hex Nut M12 (x2)



6. Lock Nut M10 (x62)

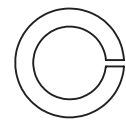

7. Spring Washer  $\phi 10$  (x56)



24. Set Screw  
M8X10 (x2)

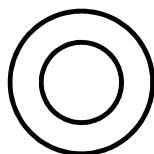

144. Flat Washer  
 $\phi 12$  (x2)

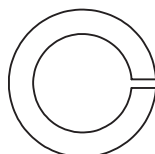

145. Spring Washer  
 $\phi 12$  (x2)

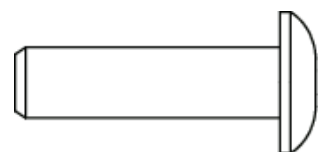

146. Button Head Screw  
M12X40 (x2)

# STEP 1 - ASSEMBLY

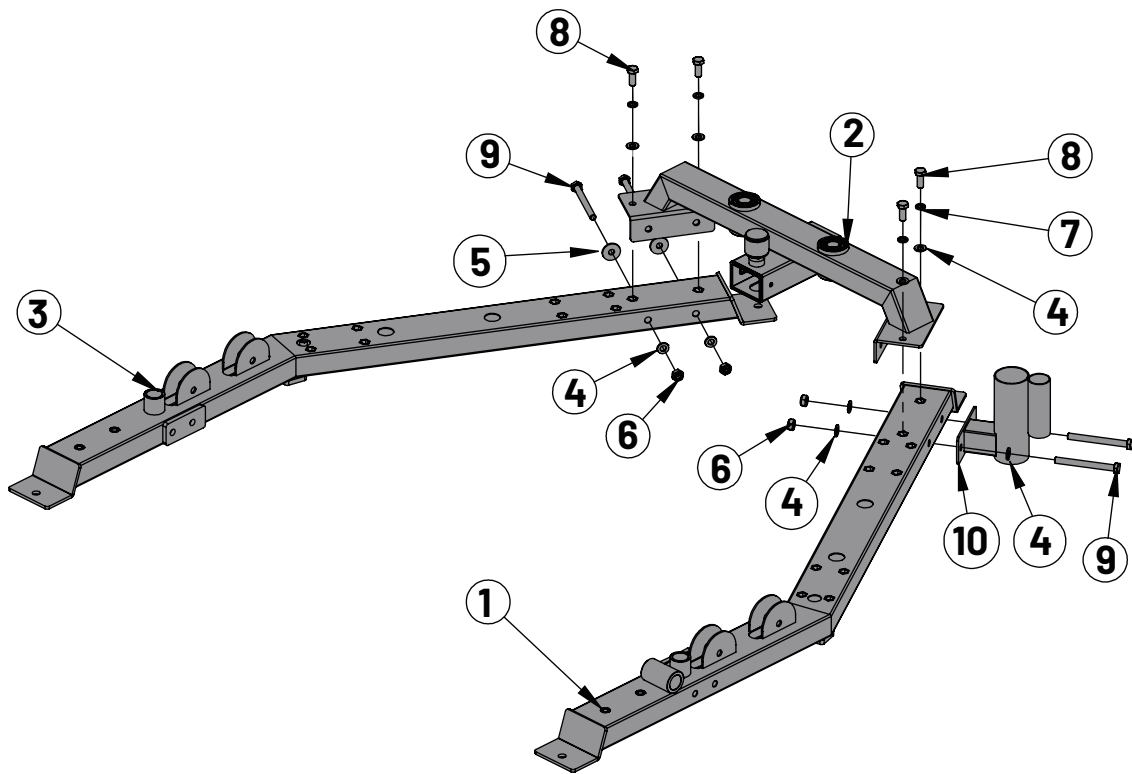

Key No.	Description	Note	Quantity
1	Base Frame - Right		1
2	Base Linking Frame		1
3	Base Frame - Left		1
4	Flat Washer	$\phi 10$	10
5	Big Flat Washer	$\phi 30 * \phi 10 * 3$	2
6	Lock Nut	M10	4
7	Spring Washer	$\phi 10$	4
8	Hexagon Bolt	M10×25	4
9	Hexagon Bolt	M10×100	4
10	Barbell Storage Holder		1

# STEP 2 - ASSEMBLY

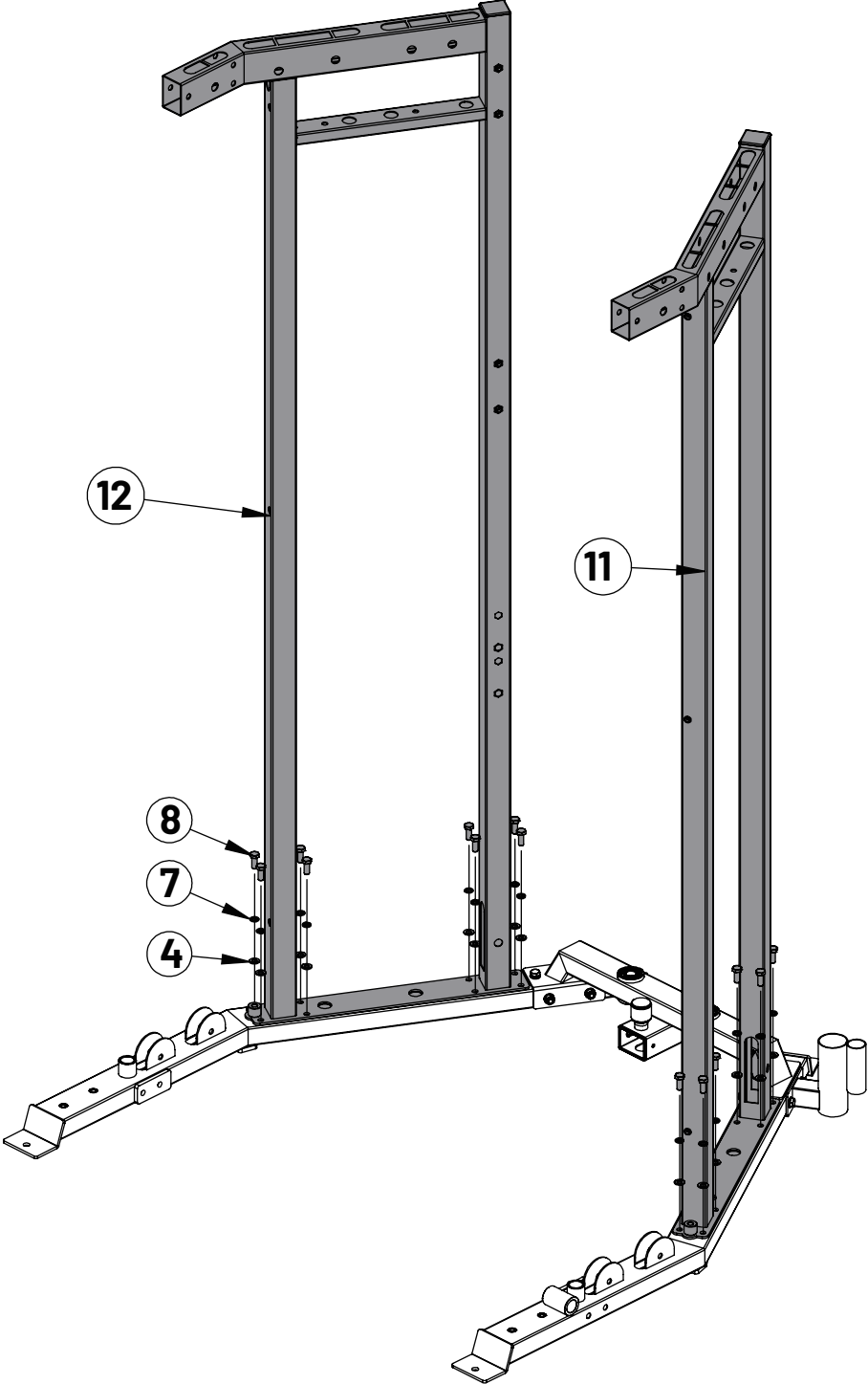

Key No.	Description	Note	Quantity
4	Flat Washer	$\phi 10$	16
7	Spring Washer	$\phi 10$	16
8	Hexagon Bolt	M10×25	16
11	Upright Frame - Right		1
12	Upright Frame - Left		1

# STEP 3 - ASSEMBLY

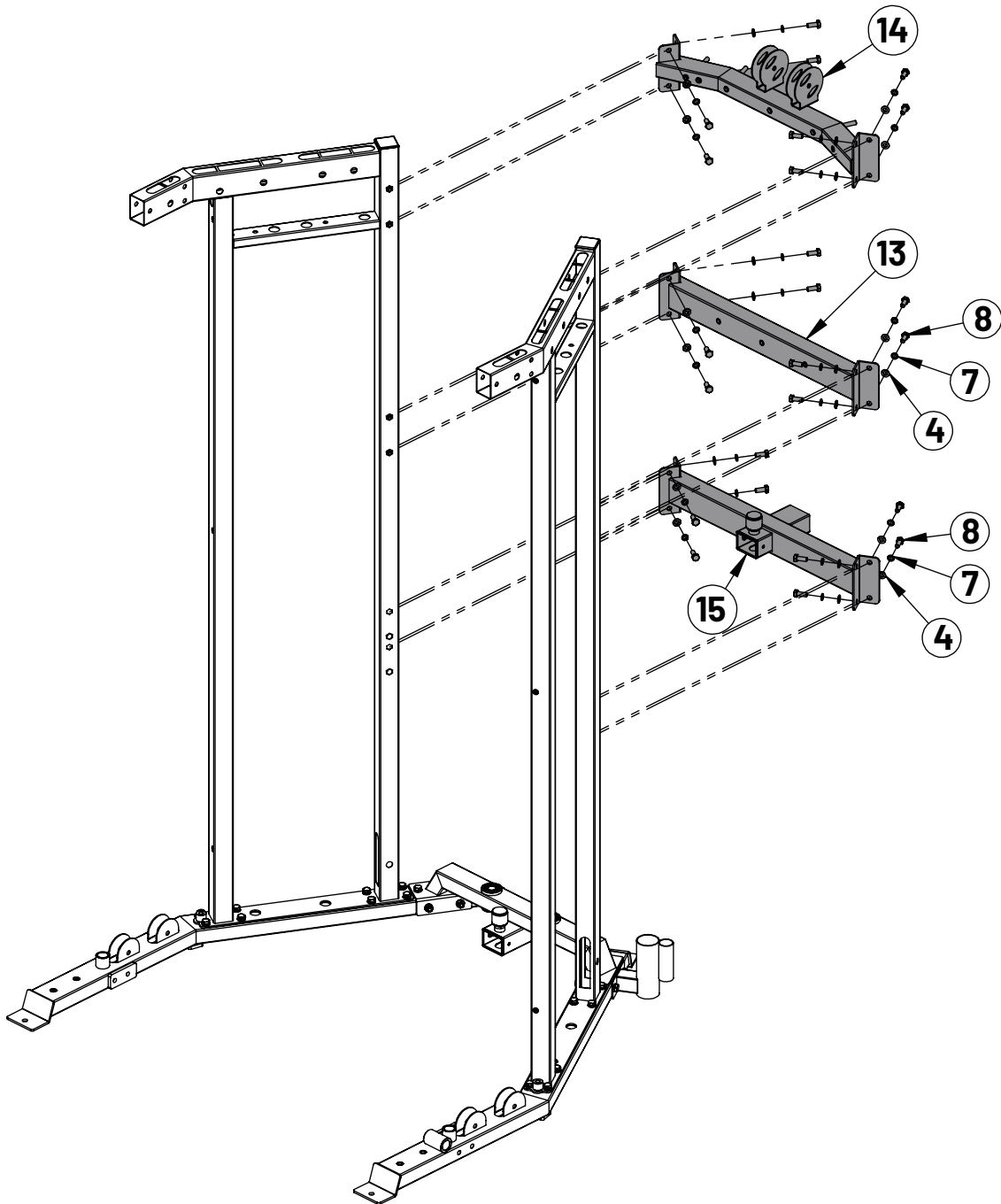

Key No.	Description	Note	Quantity
4	Flat Washer	$\phi 10$	24
7	Spring Washer	$\phi 10$	24
8	Hexagon Bolt	M10x25	24
13	Upright Linking Frame - Middle		1
14	Upright Linking Frame - Upper		1
15	Upright Linking Frame - Lower		1

# STEP 4 - ASSEMBLY



"Note: Part #16 - Front Guide Tube can be installed on either side dependent on handle orientation."

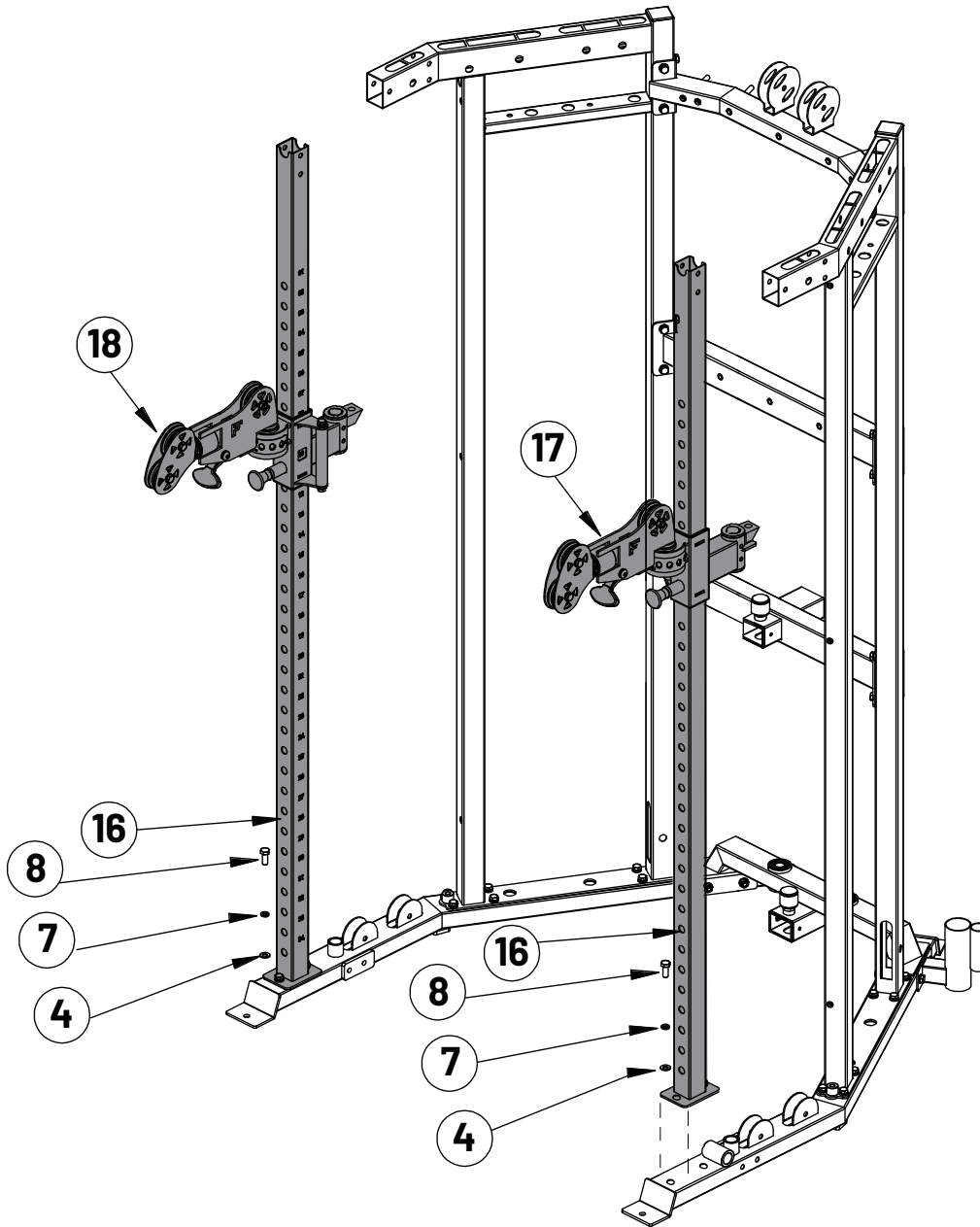

Key No.	Description	Note	Quantity
4	Flat Washer	φ10	4
7	Spring Washer	φ10	4
8	Hexagon Bolt	M10×25	4
16	Front Guide Tube		2
17	Pulley Slider - Right		1
18	Pulley Slider - Left		1



# STEP 5 - ASSEMBLY

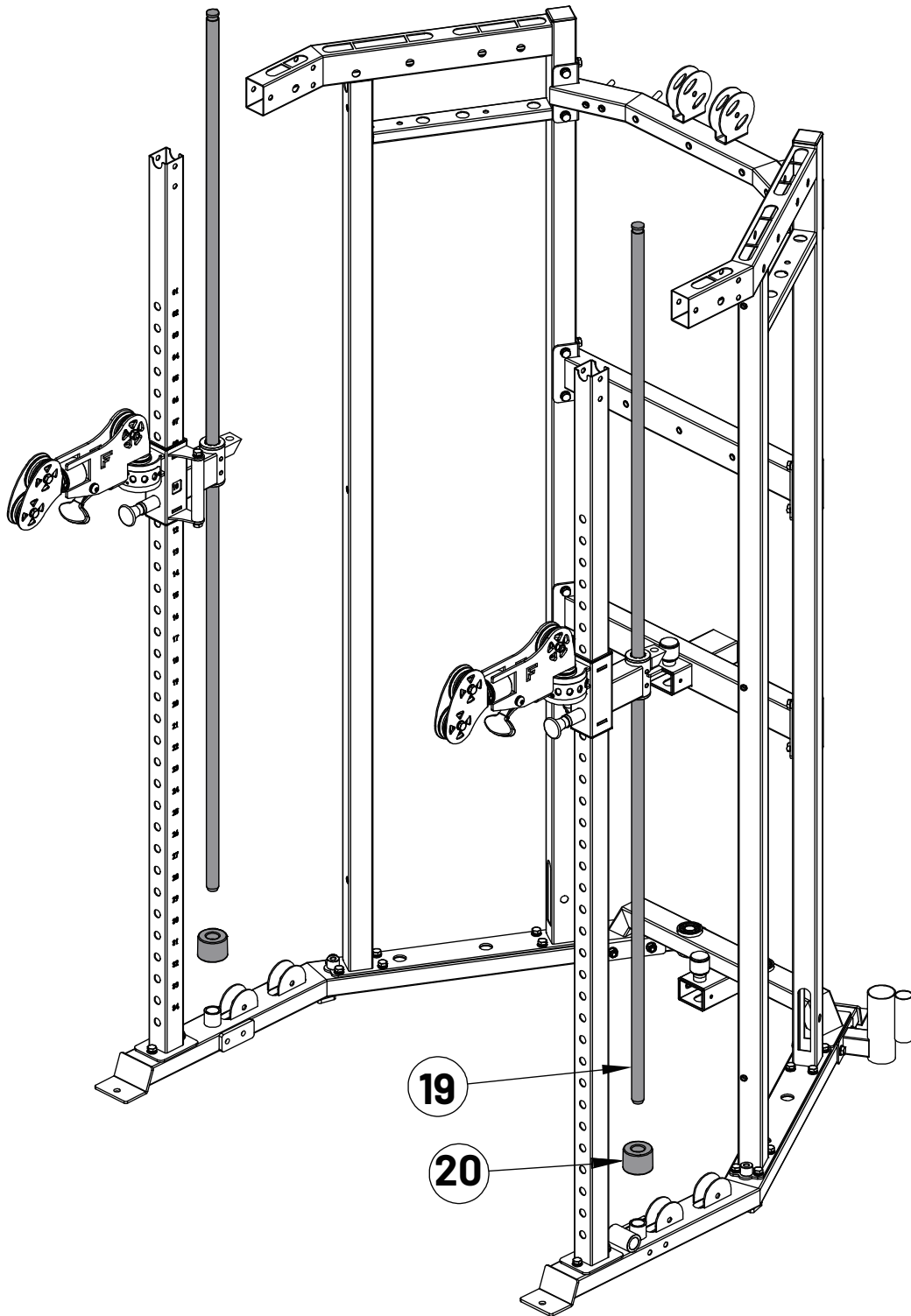

Key No.	Description	Note	Quantity
19	Guide Rod - Smith Bar	$\phi 25 \times 2021$	2
20	Rubber Bumper - Smith Bar	$\phi 60 \times \phi 26 \times 45$	2

# STEP 6 - ASSEMBLY

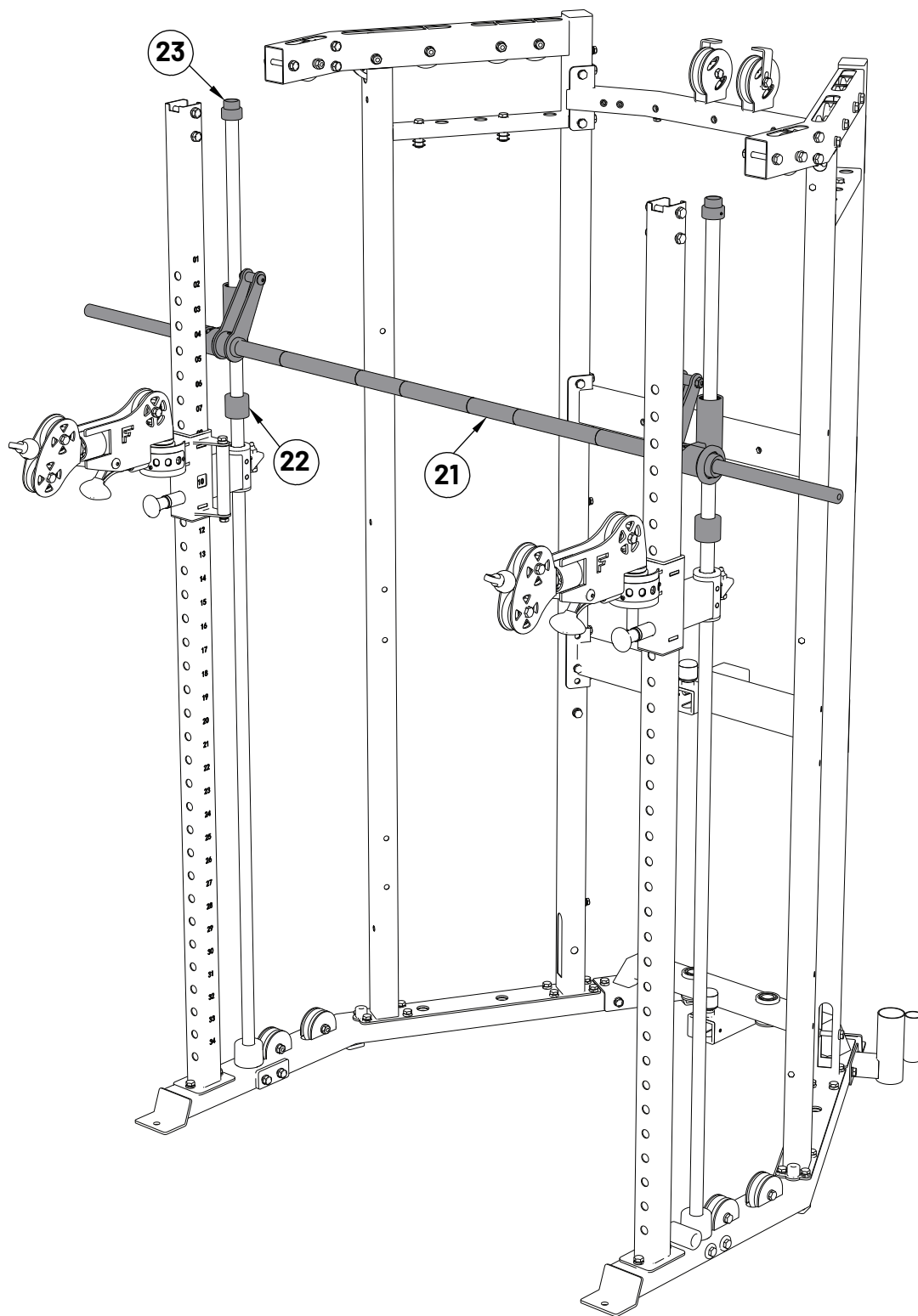

Key No.	Description	Note	Quantity
21	Smith Bar		1
22	Rubber Bumper	$\phi 48 \times \phi 25.5 \times 42$	2
23	Smith Bar Guide Rod Fixing Sleeve	$\phi 40 * \phi 25.5 * 35$	2

# STEP 7 - ASSEMBLY

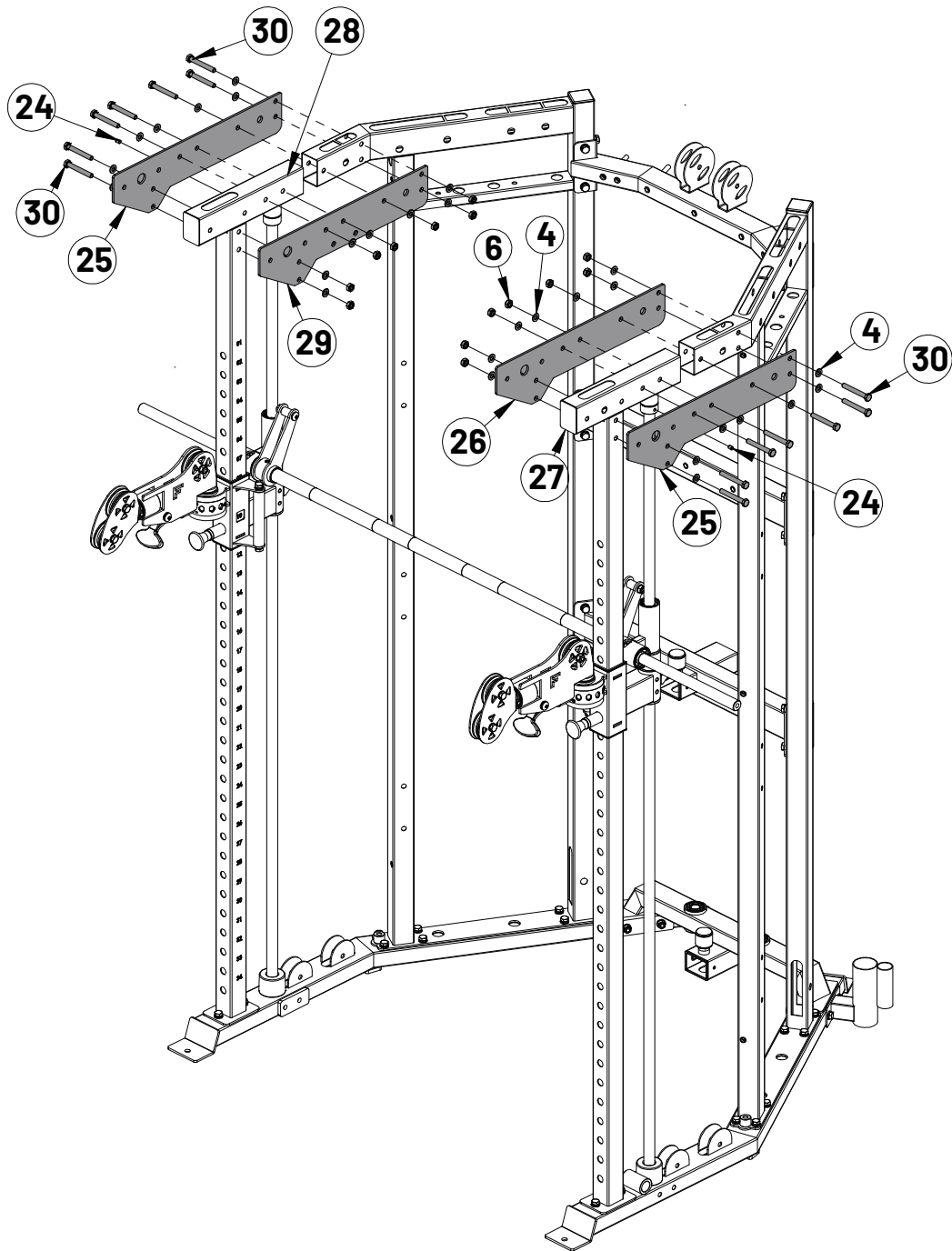

Key No.	Description	Note	Quantity
4	Flat Washer	φ10	28
6	Lock Nut	M10	14
24	Grub Screw	M8*10	2
25	Upper Cover Plate - Outside	T5	2
26	Upper Cover Plate - Inside Right		1
27	Front Upper Frame - Right		1
28	Front Upper Frame - Left		1
29	Upper Cover Plate - Inside Left		1
30	Hexagon Bolt	M10×75	14

# STEP 8 - ASSEMBLY

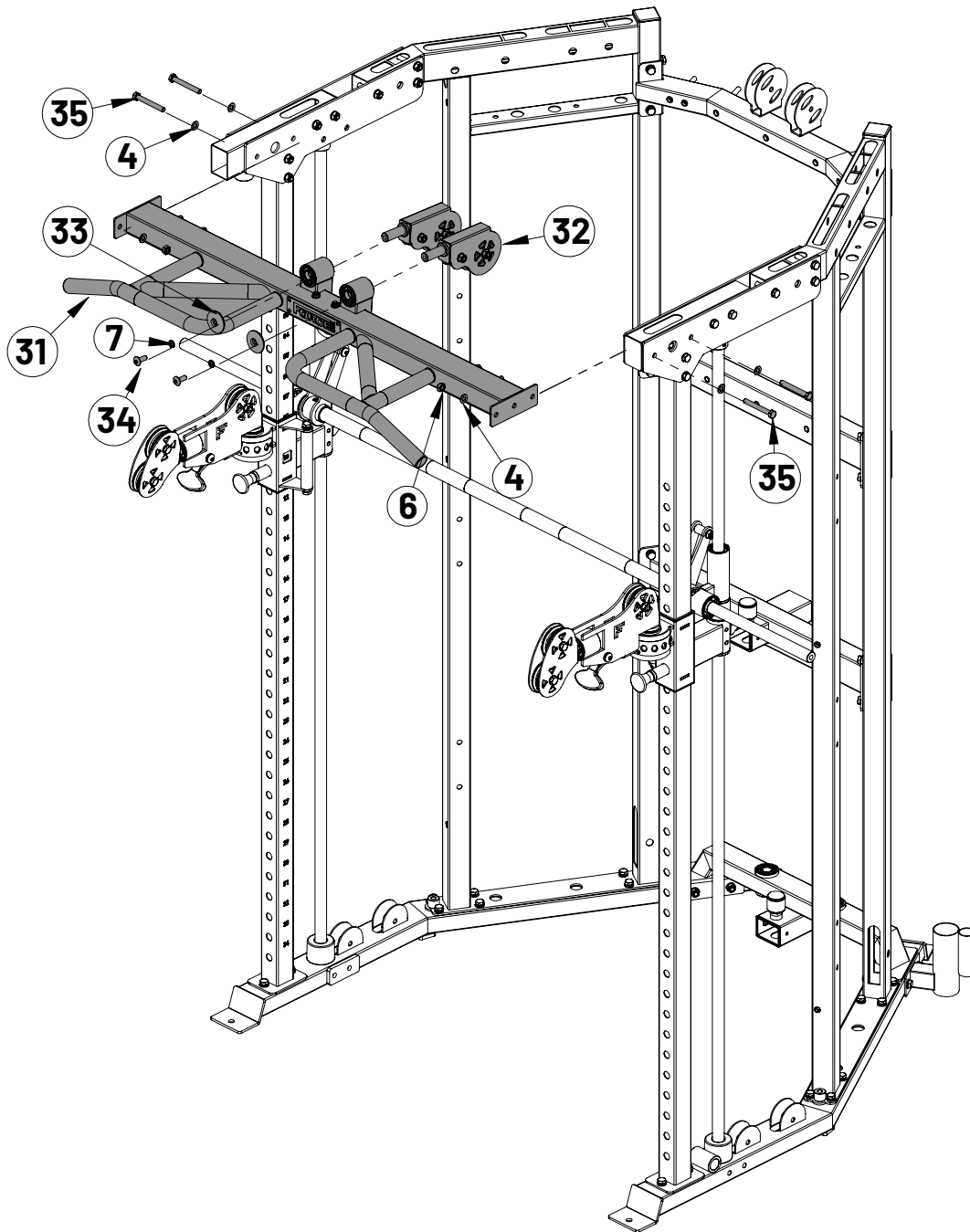

Key No.	Description	Note	Quantity
4	Flat Washer	$\phi 10$	8
6	Lock Nut	M10	4
7	Spring Washer	$\phi 10$	2
31	Multi Grip Pull Up Bar		1
32	Pulley Frame		2
33	Pulley Frame Cover Plate	$\phi 50 \times \phi 19 \times \phi 11$	2
34	Button Head Screw	M10 $\times$ 25	2
35	Hexagon Bolt	M10 $\times$ 80	4

# STEP 9 - ASSEMBLY

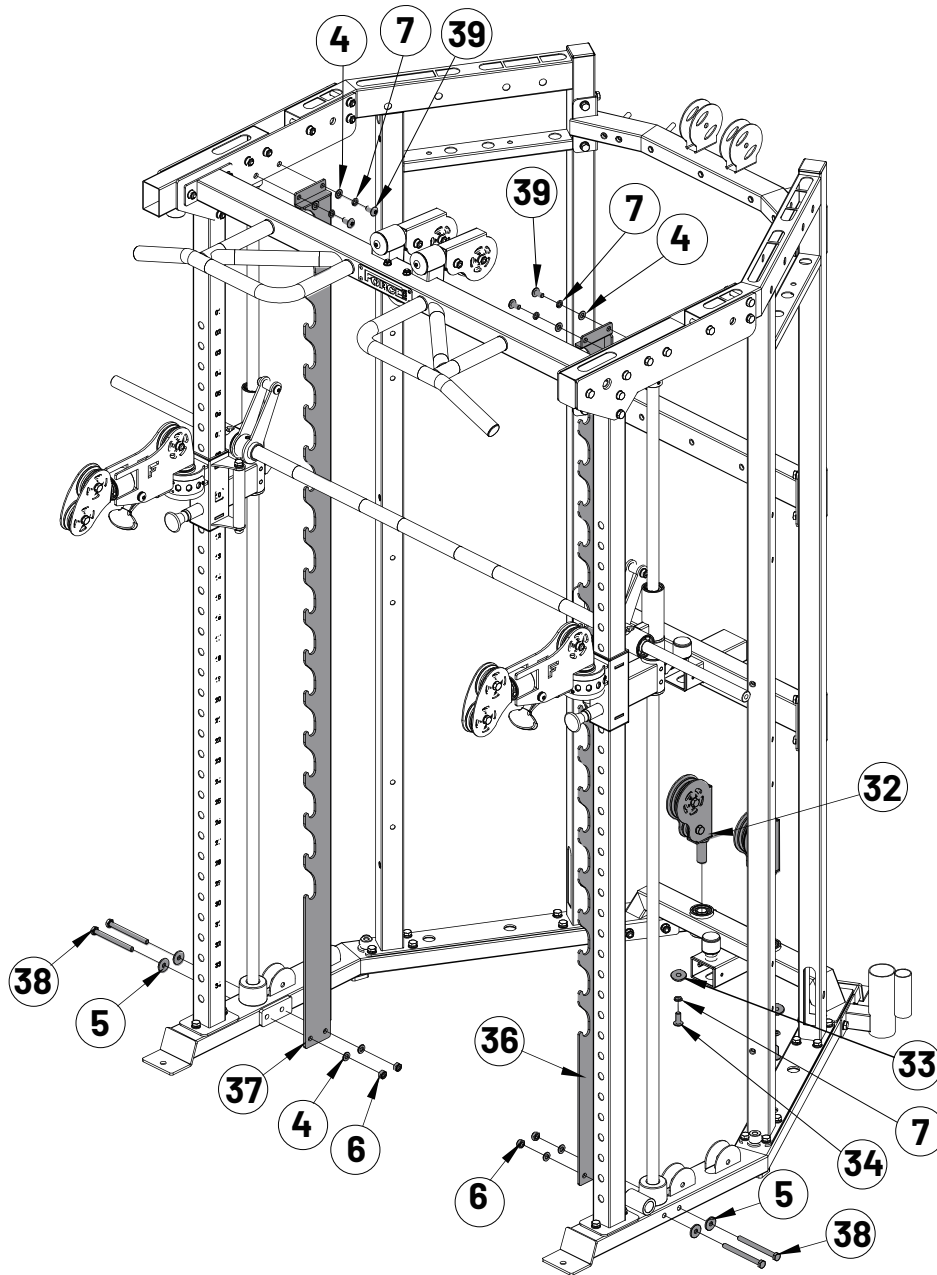

Key No.	Description	Note	Quantity
4	Flat Washer	φ10	8
5	Big Flat Washer	φ30*φ10*3	4
6	Lock Nut	M10	4
7	Spring Washer	φ10	6
32	Pulley Frame		2
33	Pulley Frame Cover Plate	φ50×φ19×φ11	2
34	Button Head Screw	M10×25	2
36	Smith Bar Racking Frame - Right		1
37	Smith Bar Racking Frame - Left		1
38	Hexagon Bolt	M10×110	4
39	Hexagon Bolt	M10×20	4

# STEP 10 - ASSEMBLY

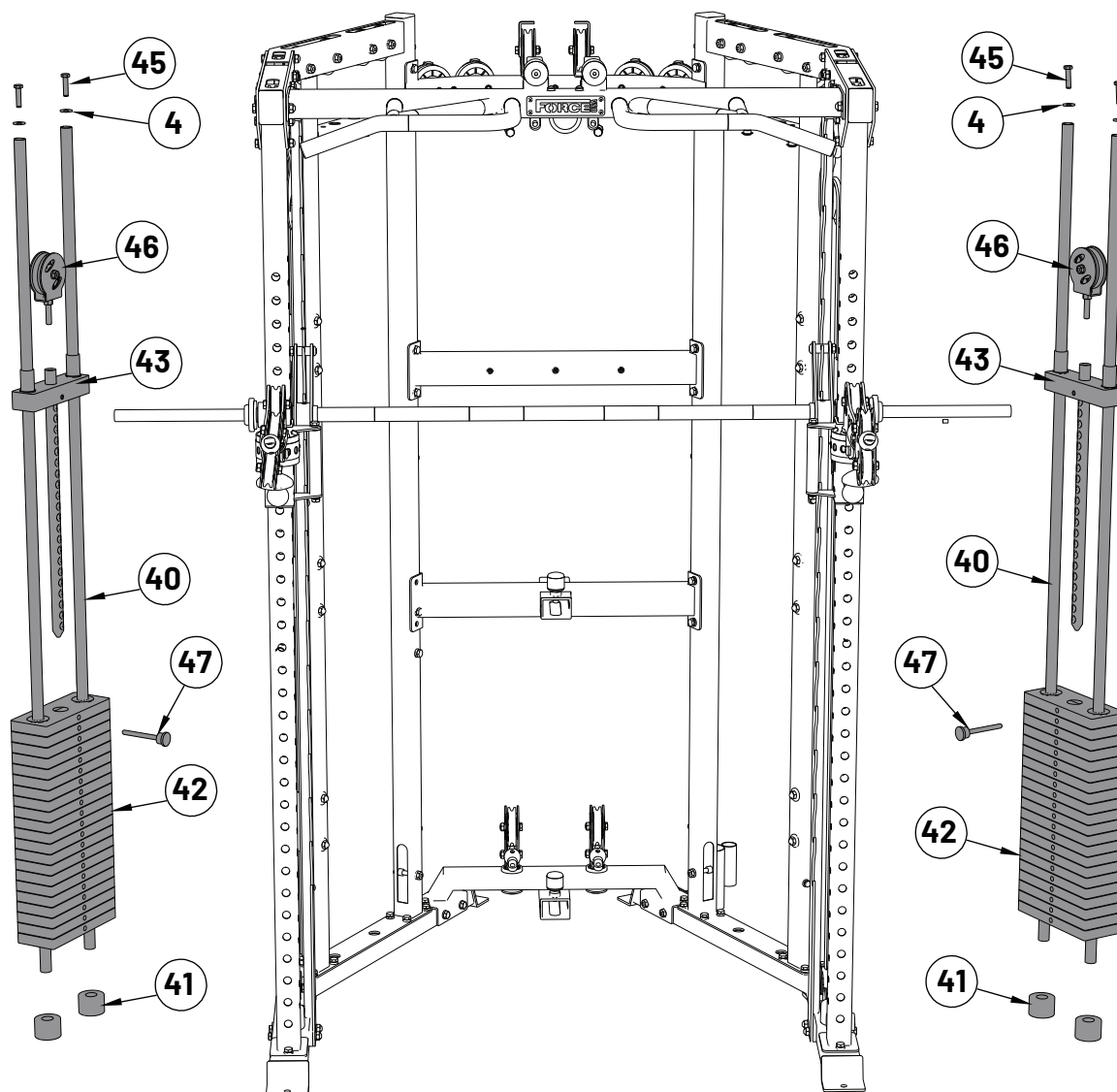

Key No.	Description	Note	Quantity
4	Flat Washer	$\phi 10$	4
40	Weight Stack Guide Rod		4
41	Rubber Bumper - Weight Stack	$\phi 60 \times \phi 27 \times 42$	4
42	Weight Stack	100KG	2
43	Selector Rod	$\phi 25$	2
45	Hexagon Bolt	M10 $\times$ 50	4
46	Weight Stack Pulley Frame		2
47	Weight Stack Selector Pin	$\phi 10 \times 100$	2

# STEP 11 - ASSEMBLY

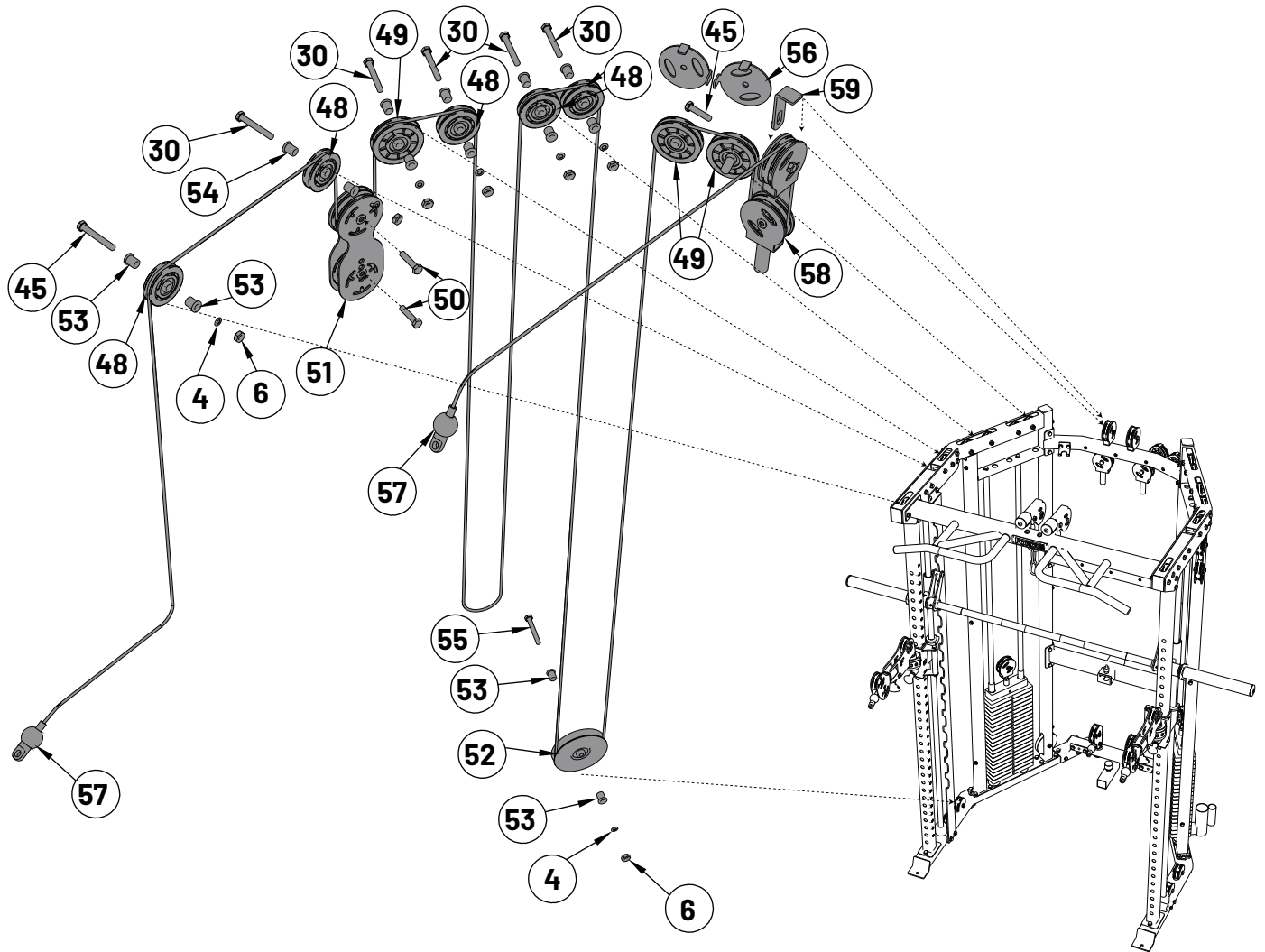

Key No.	Description	Note	Quantity
4	Flat Washer	$\phi 10$	12
6	Lock Nut	M10	20
30	Hexagon Bolt	M10 $\times$ 75	2
45	Hexagon Bolt	M10 $\times$ 50	4
48	Small Pulley	$\phi 75$	10
49	Medium Pulley	$\phi 92$	10
50	Hexagon Bolt Floating	M10 $\times$ 45	2
51	Pulley Frame		2
52	Large Pulley	$\phi 127$	2
53	Small Bushing	$\phi 20 \times \phi 16 \times \phi 10.5 \times 15$	22
54	Large Bushing	$\phi 20 \times \phi 16 \times \phi 10.5 \times 20.5$	4
55	Hexagon Bolt	M10 $\times$ 65	10
56	Pulley Cover	T3	4
57	Front and Upper Pull Cable	13690mm	2
58	Rear Pull Cable Floating Pulley		2
59	Pulley Cable Guide	T4	2

# STEP 12 - ASSEMBLY

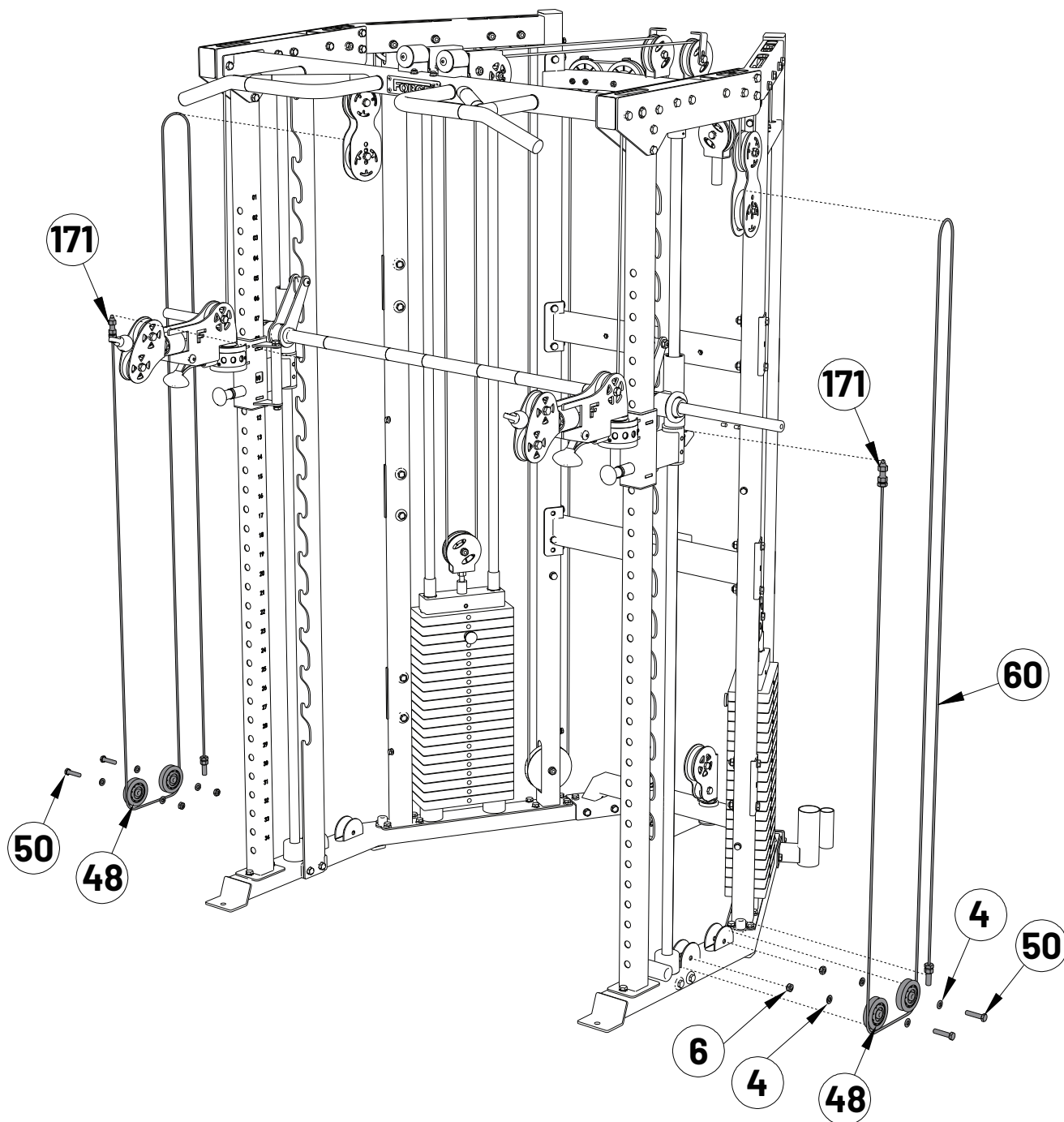

Key No.	Description	Note	Quantity
4	Flat Washer	$\phi 10$	8
6	Lock Nut	M10	4
48	Small Pulley	$\phi 75$	4
50	Hexagon Bolt	M10×45	4
60	Smith Bar Cable	2415mm	2
171	Hexagonal Nut	M12	2



# STEP 13 - ASSEMBLY

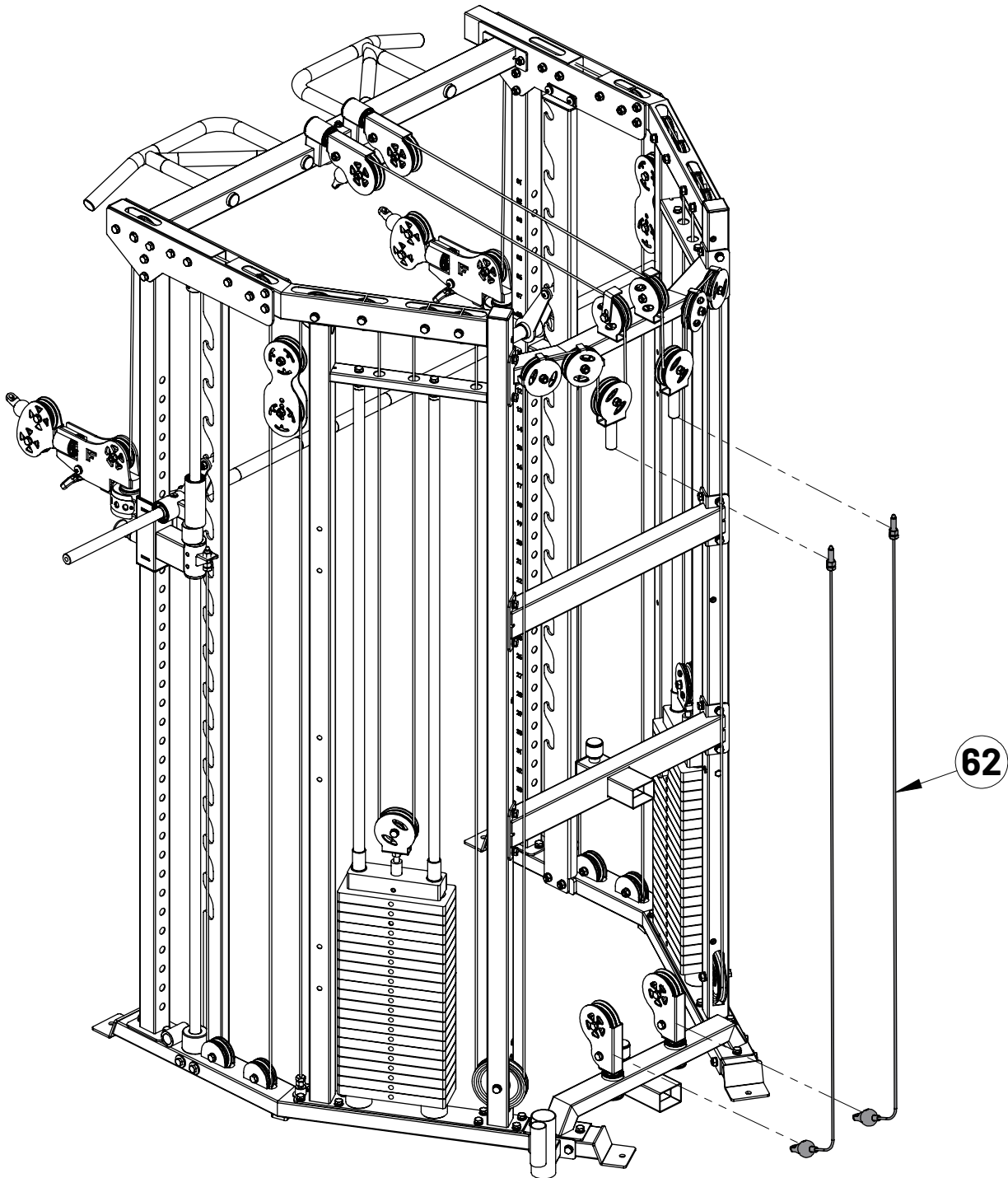

Key No.	Description	Note	Quantity
62	Rear Pull Cable	1620mm	2

# STEP 14 - ASSEMBLY

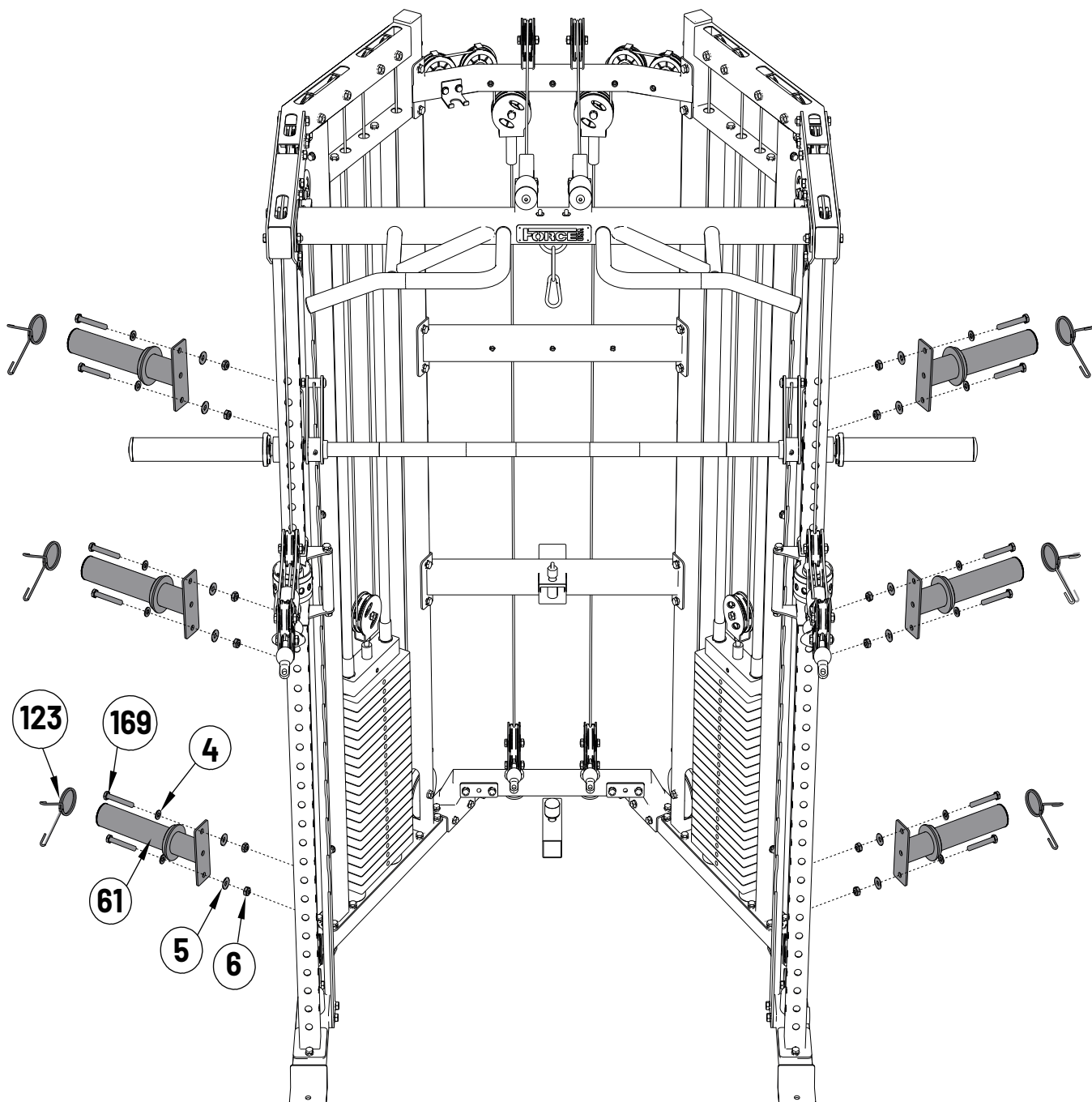

Key No.	Description	Note	Quantity
4	Flat Washer	$\phi 10$	12
5	Big Flat Washer	$30*\phi 10*3$	12
6	Lock Nut	M10	12
61	Olympic Weight Plate Holder		6
123	Olympic Spring Collar	$\phi 50$	6
169	Hexagon Bolt Button Head Screw	M10x70	12

# STEP 15 - ASSEMBLY

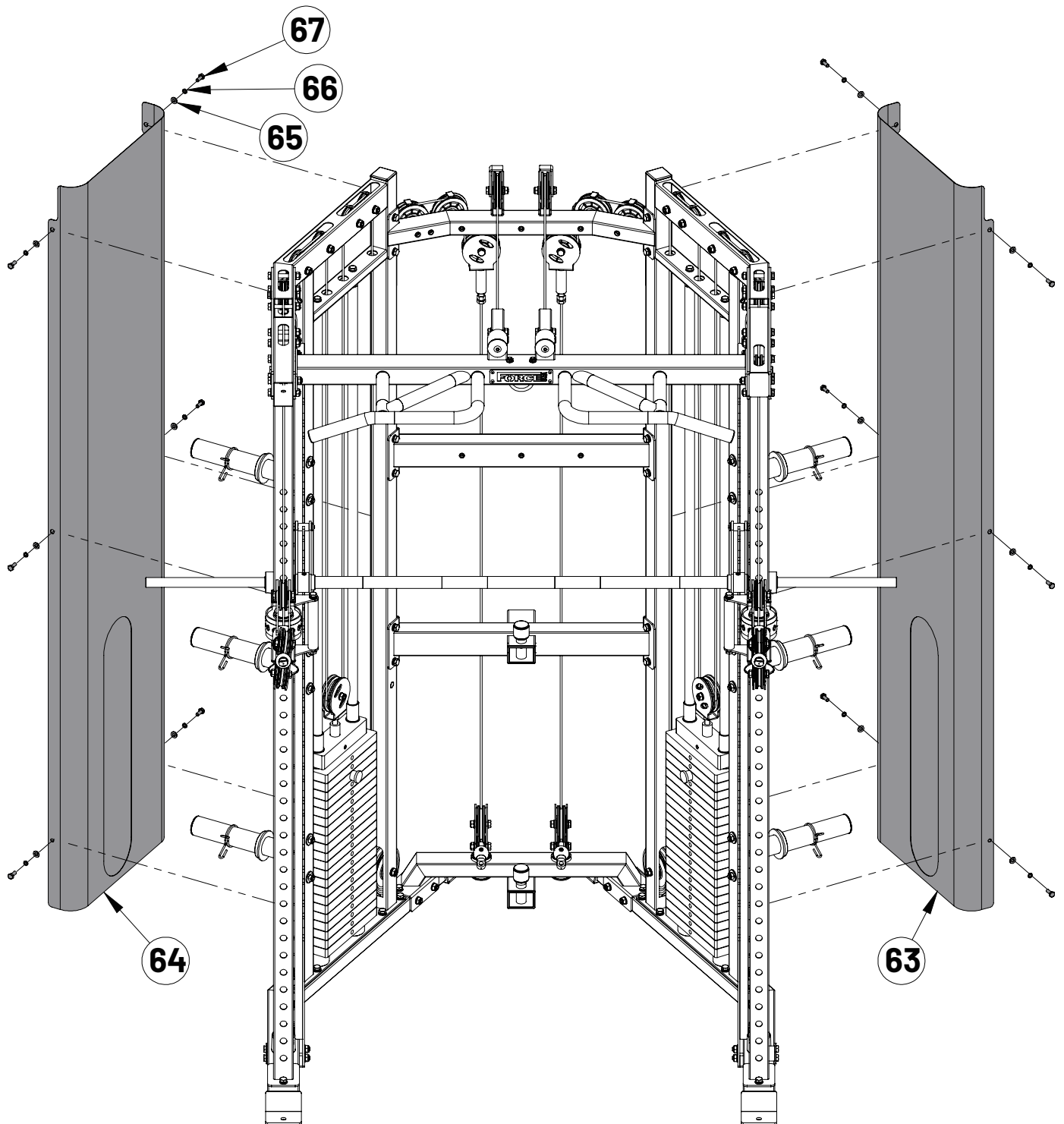

Key No.	Description	Note	Quantity
63	Weight Stack Shield - Right	T1	1
64	Weight Stack Shield - Left	T1	1
65	Flat Washer	φ8	12
66	Spring Washer	φ8	12
67	Hexagon Bolt	M8×20	12

# STEP 16 - ASSEMBLY

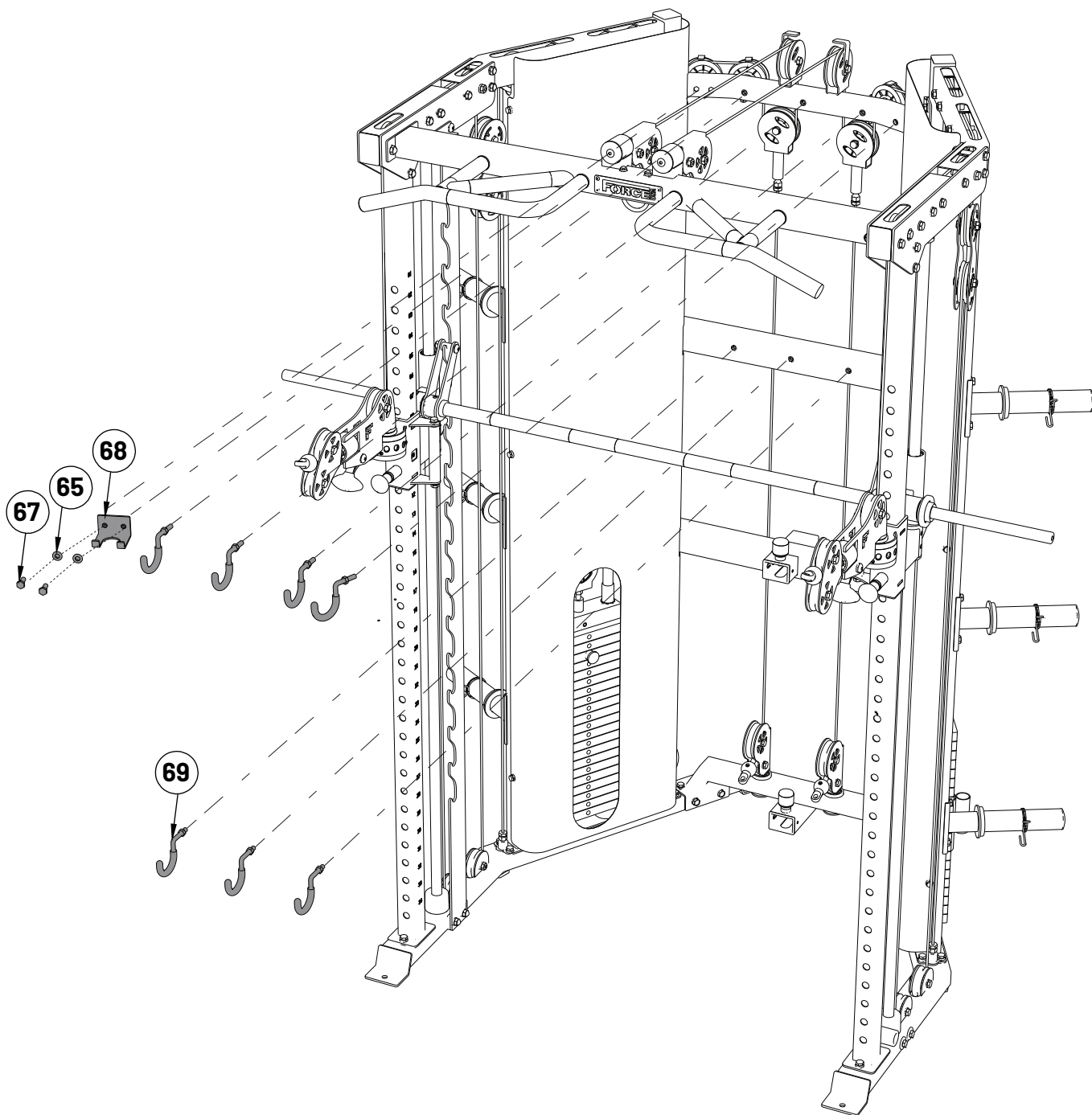

Key No.	Description	Note	Quantity
65	Flat Washer	φ8	2
67	Hexagon Bolt	M8×20	2
68	Accessory Hook Plate	T3	1
69	Accessory Hook		7

# STEP 17 - ASSEMBLY

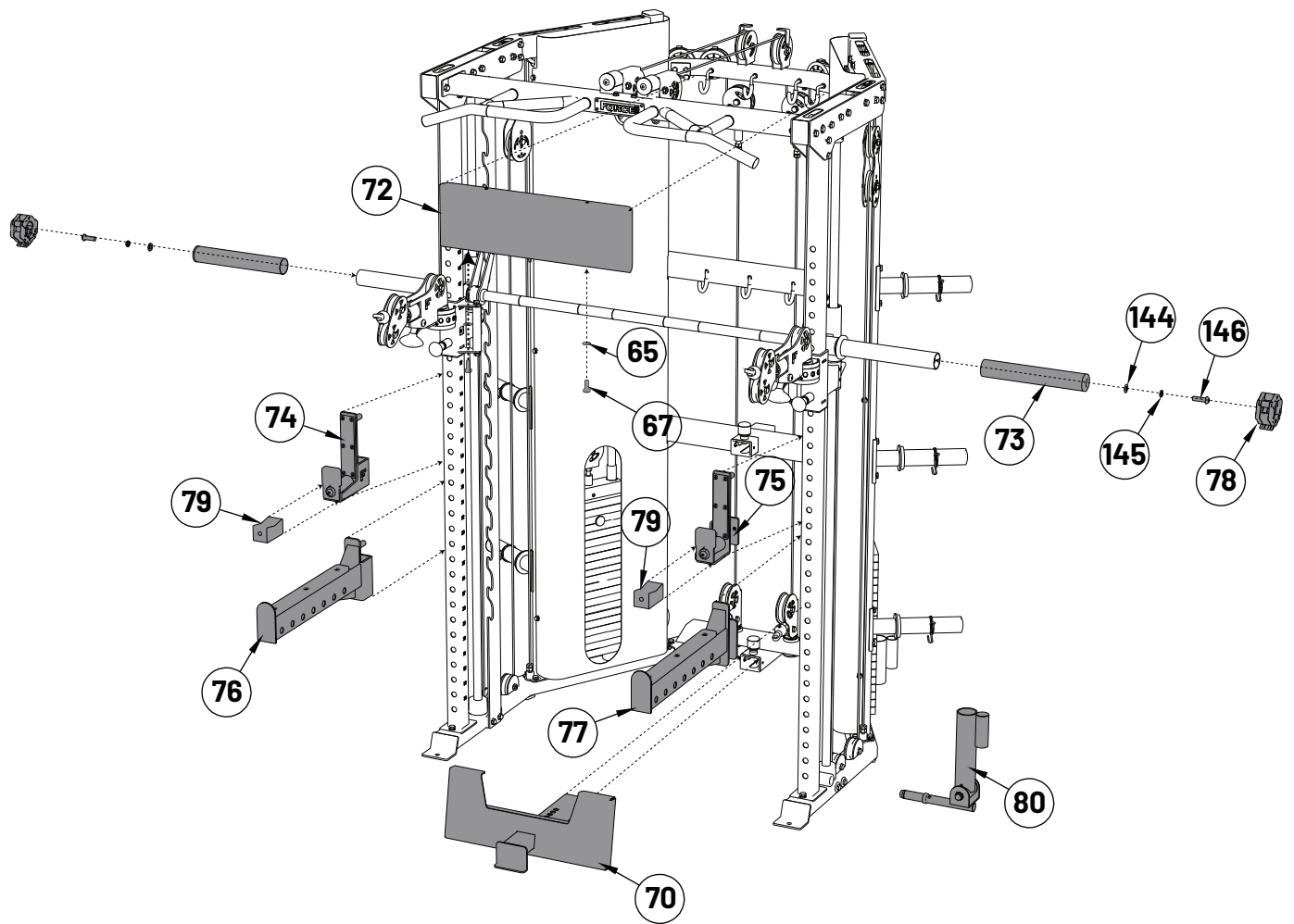

Key No.	Description	Note	Quantity
73	Smith Bar Olympic Sleeve		2
74	J-Hook - Left		1
75	J-Hook - Right		1
76	Front Safety - Left		1
77	Front Safety - Right		1
78	Olympic Quick Lock Collar	Φ85XΦ50XH49	2
79	J Hook Flat Shock Pad		2
80	Landmine/Core trainer		1
144	Flat Washer	Φ12	2
145	Spring Washer	Φ12	2
146	Hexagon Socket Button Head Screw	M10×35	2
65	Flat Washer	8	2
67	Hexagon Bolt	M8×20	2
70	Low Row Footplate		1
72	Logo Board	T2	1

# ATTACHMENTS AND ACCESSORIES

Illustrations may appear different than actual attachments

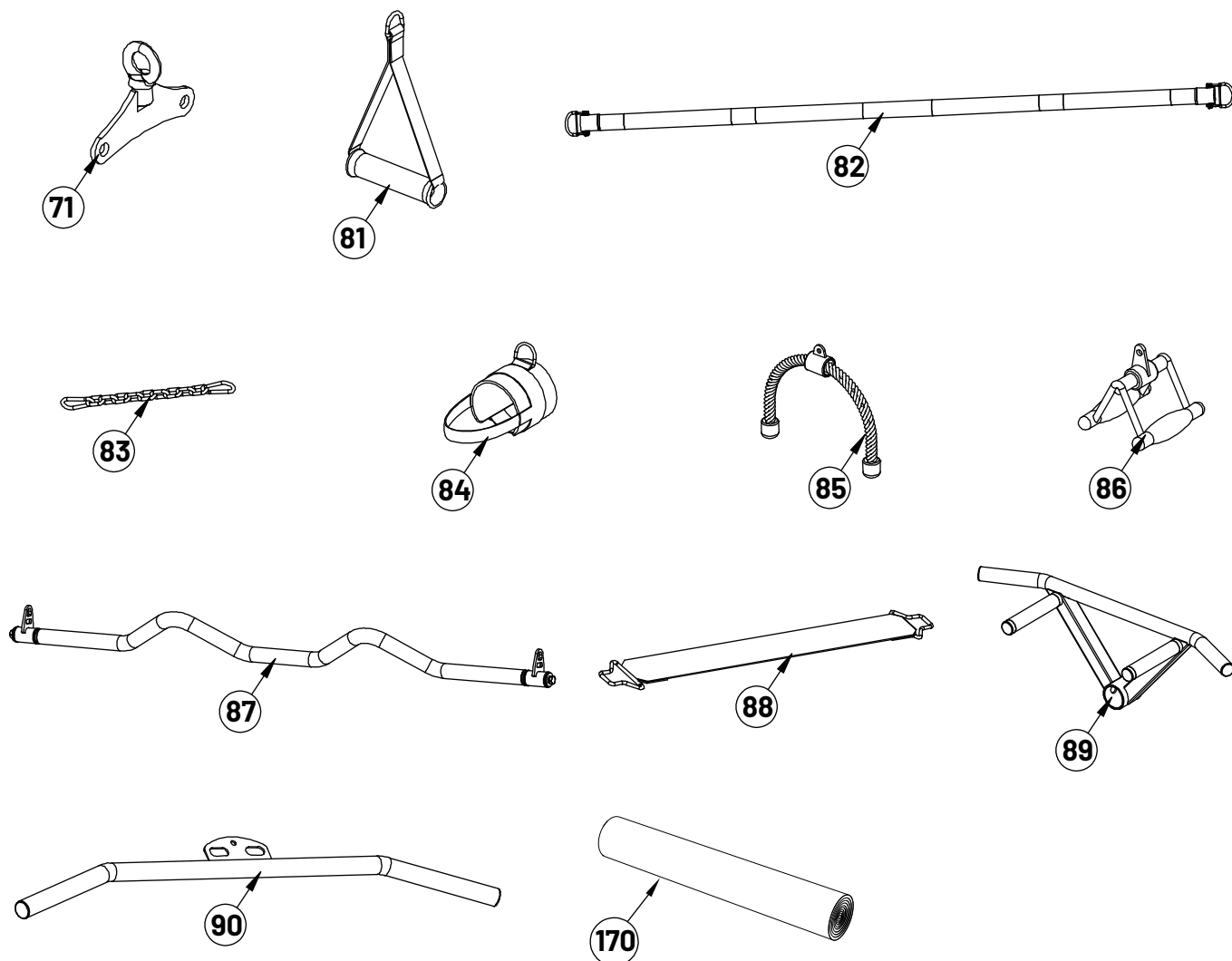

Key No.	Description	Note	Quantity
81	Single Stirrup		2
82	Connection Bar - Straight		1
83	Extension Chain		4
84	Ankle Cuff		1
85	Tricep Rope		1
86	Close Grip Triangle		1
87	Connection Bar - EZ Curl	Length 1020mm	1
88	Bodyweight Assist Strap		1
89	Core Trainer Handle		1
90	Lat Pull Down Bar		1
71	Dual Cable Connector		1
170	Foam Pad	700mm	1

# EXPLODED DIAGRAMS

The upcoming pages feature an exploded view drawing of your product. These diagrams visually represents each component as it relates to the whole, although additional assembly by you is not required. It serves to help you identify and understand every part included in your purchase. While this guide offers a clear insight into how these parts fit together, it is particularly useful for troubleshooting and maintaining your product. Beyond practical benefits, the exploded view also aims to enhance your understanding of the product's design and functionality. As you explore these pages, you'll find they make it easier to discuss any component with our customer support, should the need arise. We hope this detailed visual approach not only informs but also enriches your experience with your new purchase.

- 1.Base Frame - Right, 1 pc
- 3.Base Frame - Left, 1 pc

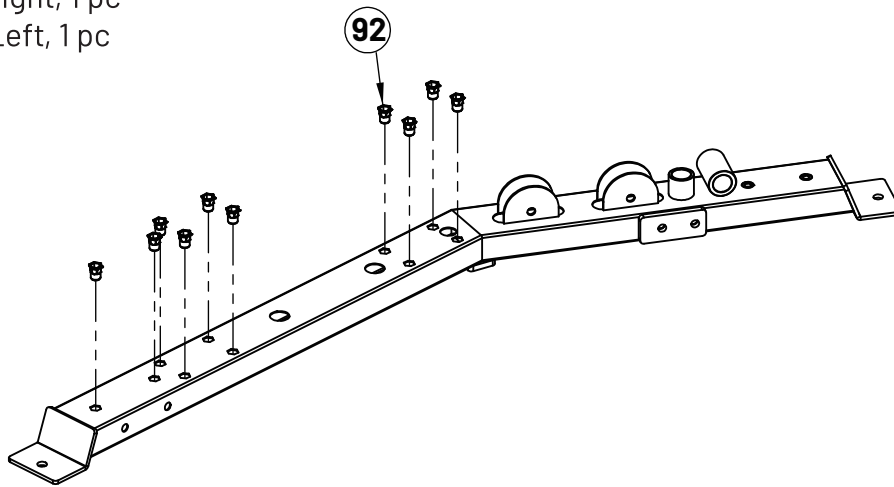

Key No.	Description	Note	Quantity
92	Countersunk Head Hexagon Rivet Screw	M10	10

- 2.Base Linking Frame, 1 pc

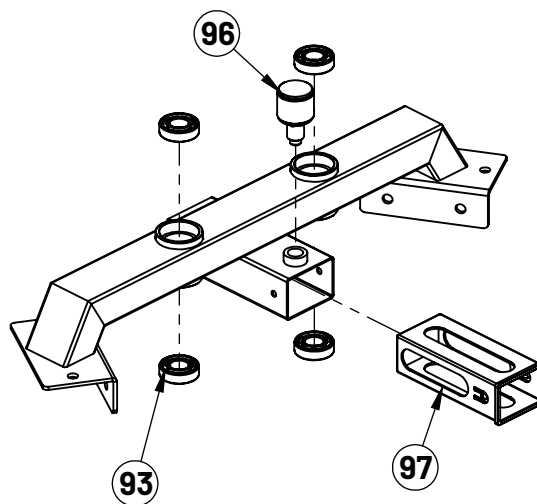

Key No.	Description	Note	Quantity
93	Deep Ball Bearing	6004	4
96	Pull Pin	φ12	1
97	Reducer Sleeve	F50-70/F40-60	1

# EXPLODED DIAGRAMS

- 11.Upright Frame - Right, 1 pc
- 12.Upright Frame - Left, 1 pc

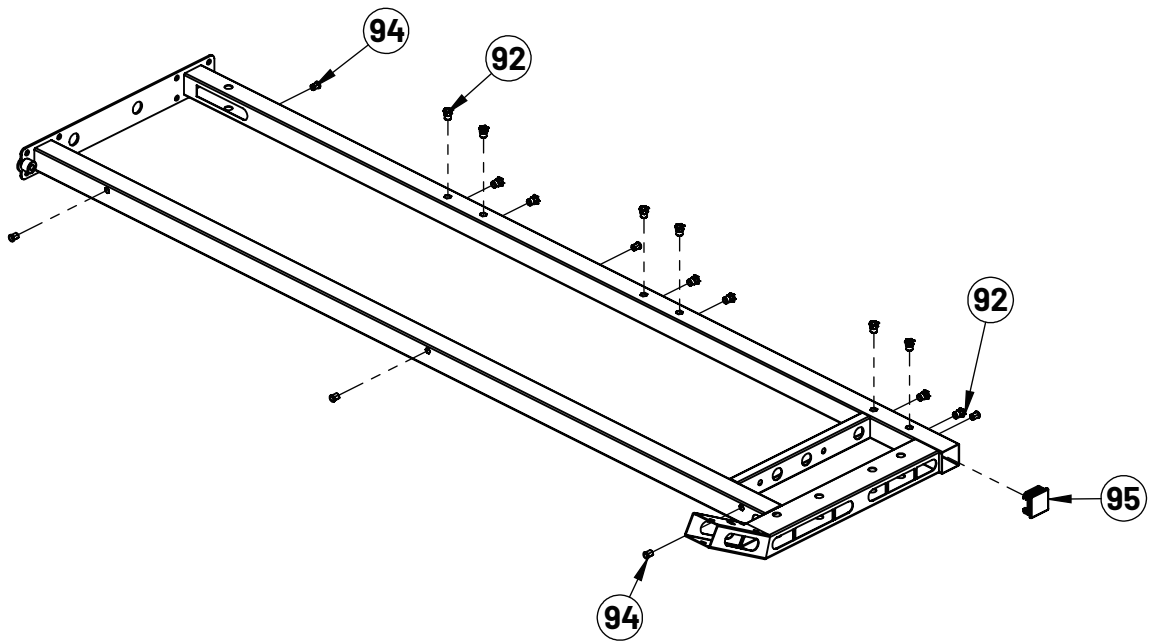

Key No.	Description	Note	Quantity
92	Countersunk Head Hexagon Rivet Screw	M10	12
94	Hexagon Rivet Screw	M8	6
95	Square Tube Inner Plug	□50×50×2	1

- 15.Upright Linking Frame - Lower, 1 pc

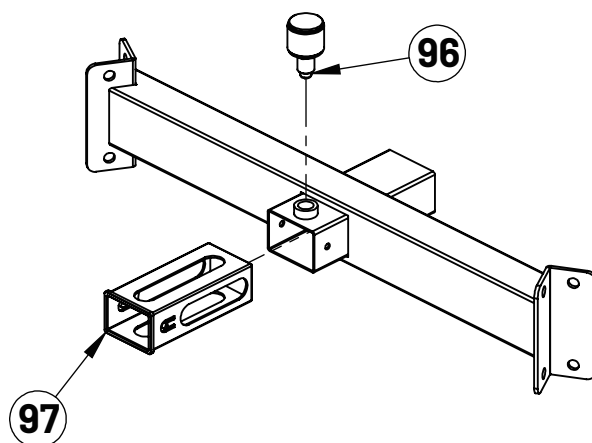

Key No.	Description	Note	Quantity
96	Pull Pin	φ12	1
97	Reducer Sleeve	F50-70/F40-60	1



# EXPLODED DIAGRAMS

13.Upright Linking Frame - Middle, 1 pc

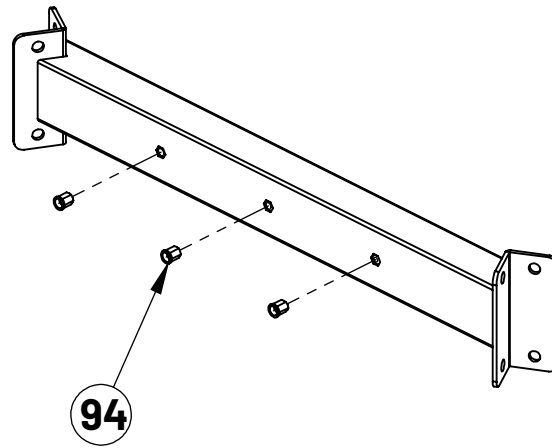

Key No.	Description	Note	Quantity
94	Hexagon Rivet Screw	M8	3

14.Upright Linking Frame - Upper, 1 pc

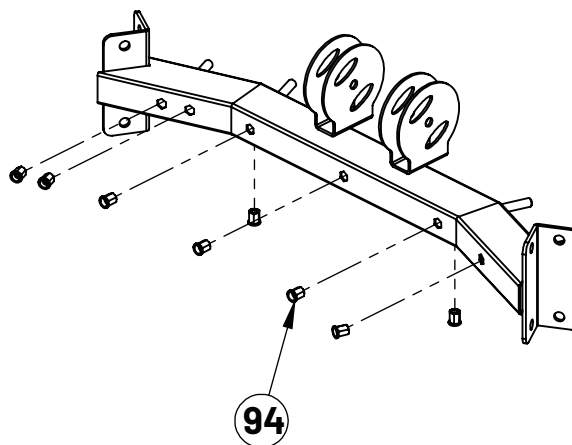

Key No.	Description	Note	Quantity
94	Hexagon Rivet Screw	M8	8

# EXPLODED DIAGRAMS

17. Pulley Slider - Right, 1 pc

18. Pulley Slider - Left, 1 pc

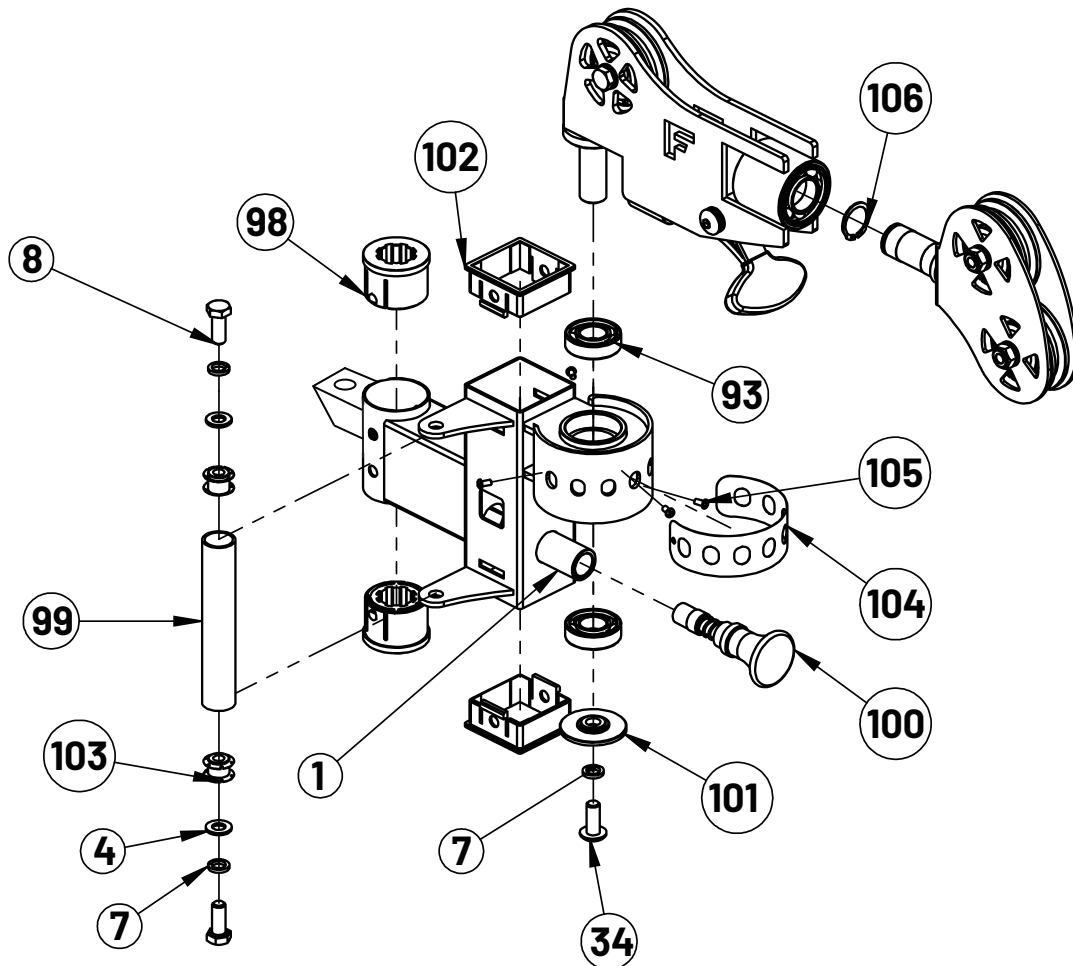

Key No.	Description	Note	Quantity
4	Flat Washer	φ10	2
7	Spring Washer	φ10	3
8	Hexagon Bolt	M10×25	2
34	Inner Hexagon Flat Round Bolt	M10×25	1
93	Deep Ball Bearing	6004	2
98	Nylon Guide Sleeve	φ50*φ26.5*35	2
99	Handgrip Tube	φ25*2	1
100	Umbrella Pull Pin	φ12×M20×40-φ16	1
101	Decorative Cover	φ50×φ24×φ19×φ11	1
102	Bushing	50-60	2
103	Two Layer Spring Slice Screw	φ23-M10	2
104	Decorative Plate	T0.3	1
105	Cross Recessed Coiled Head Bolt	M4×8	4
106	Spring Stopper Collar	φ25	1

# EXPLODED DIAGRAMS

## 21.Smith Bar, 1 pc

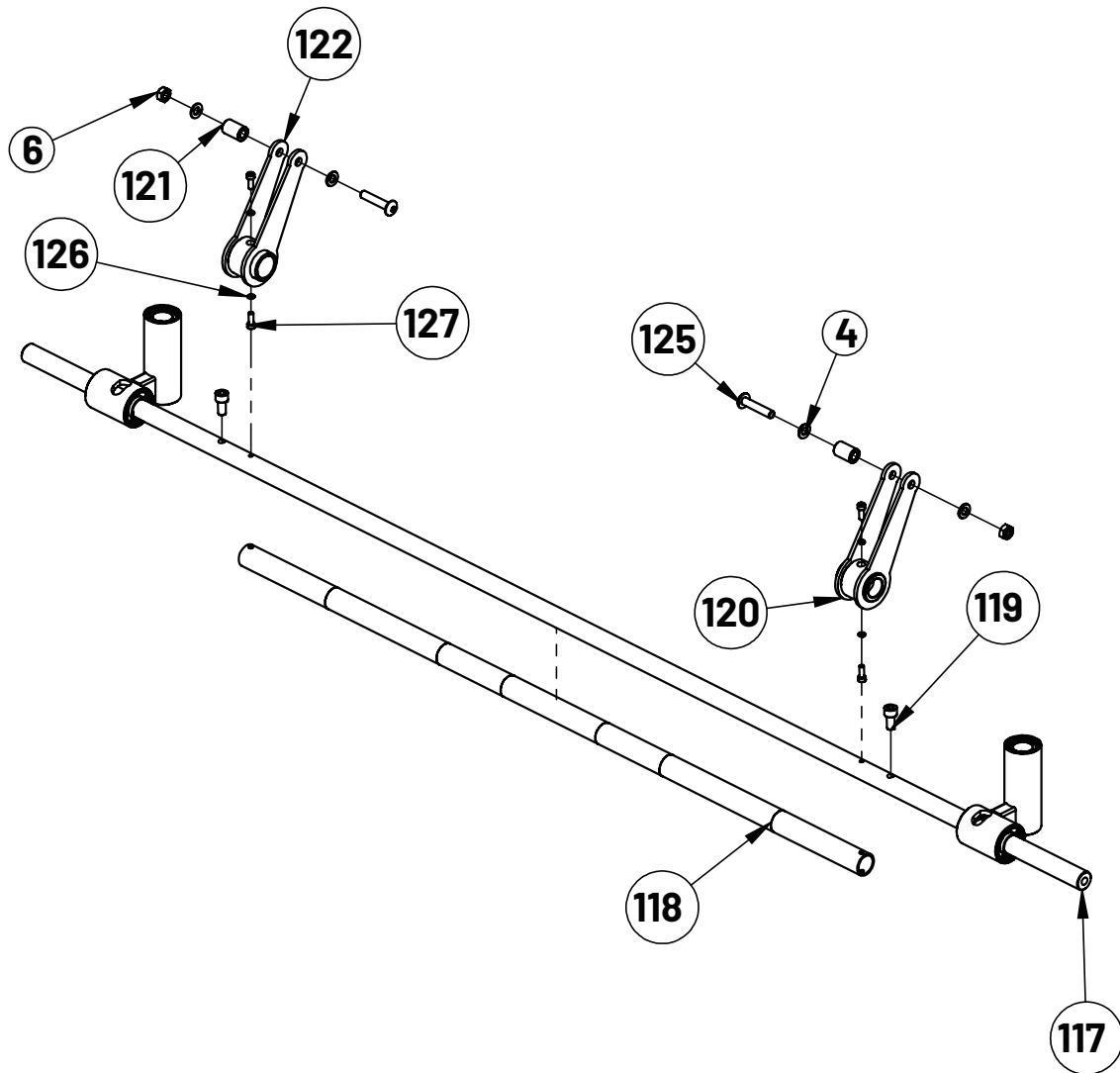

Key No.	Description	Note	Quantity
4	Flat Washer	$\phi 10$	4
6	Lock Nut	M10	2
117	Barbell Inner Rod	$\phi 24.9 \times 1254$	1
118	Long Barbell Bar	$\phi 30 \times 1110$	1
119	Inner Hexagon Round Screw	M10 $\times$ 20	2
120	Rotating Plate Right		1
121	Nylon Hook Sleeve	$\phi 19$	2
122	Rotating Plate Left		1
125	Inner Hexagon Flat Round Screw	M10 $\times$ 50	2
126	Spring Gasket	$\phi 6$	4
127	Inner Hexagon Flat Round Screw	M6 $\times$ 16	4

# EXPLODED DIAGRAMS

31.Chin Up Frame, 1 pc

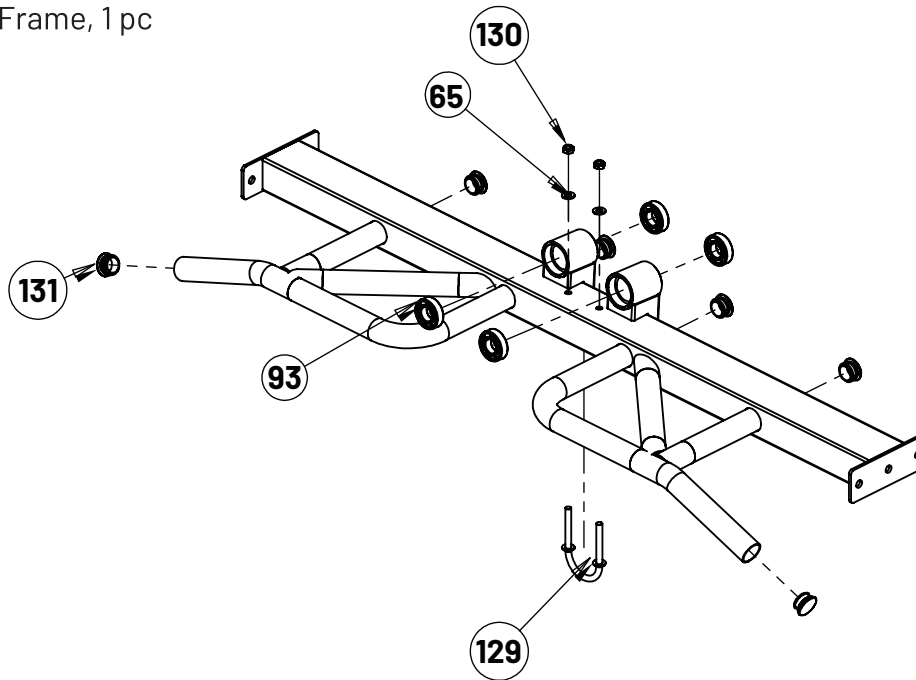

Key No.	Description	Note	Quantity
65	Flat Washer	φ8	2
93	Deep Ball Bearing	6004	4
129	50 surface Hook Ring		1
130	Lock Nut	M8	2
131	Round Tube Plug	φ32×1.5	6

32.Pulley Frame, 1 pc

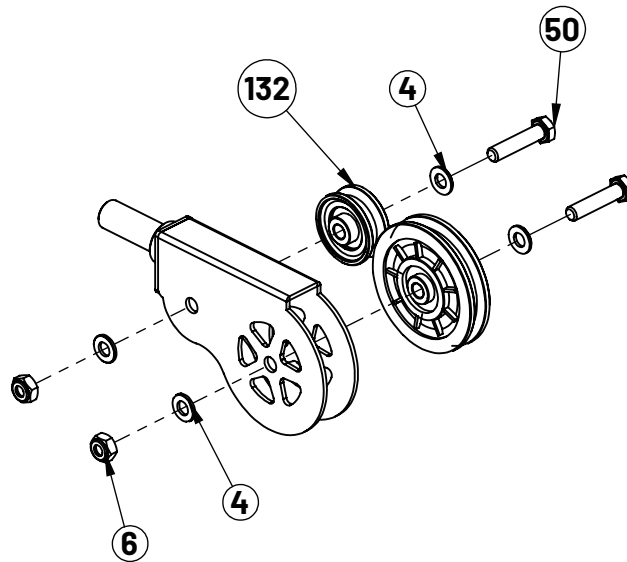

Key No.	Description	Note	Quantity
4	Flat Washer	φ10	4
6	Lock Nut	M10	2
49	Medium Pulley	φ92	1
50	Hexagon Bolt	M10×45	2
132	Pulley	φ50	1

# EXPLODED DIAGRAMS

40.Weight Stack Guide Rod, 4 pcs

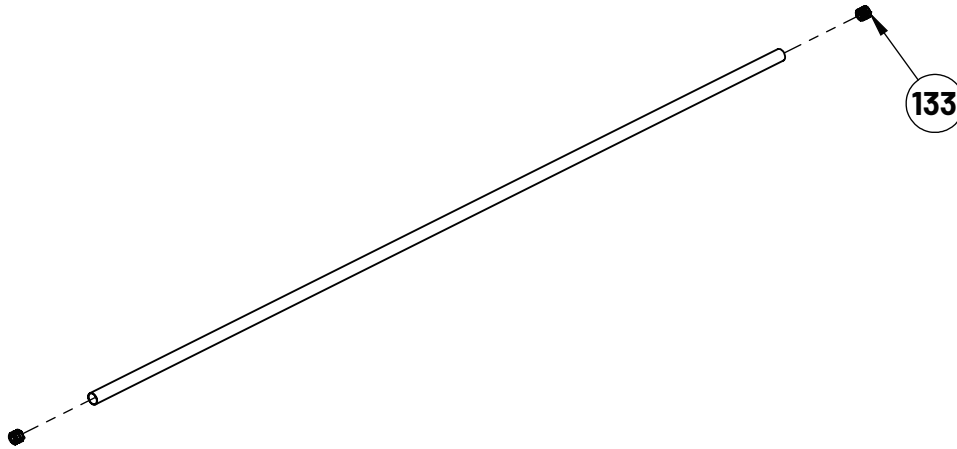

Key No.	Description	Note	Quantity
133	Three Layer Spring Slice Screw	φ24.8-M10	2

46.Weight Stack Pulley Frame, 2 pcs

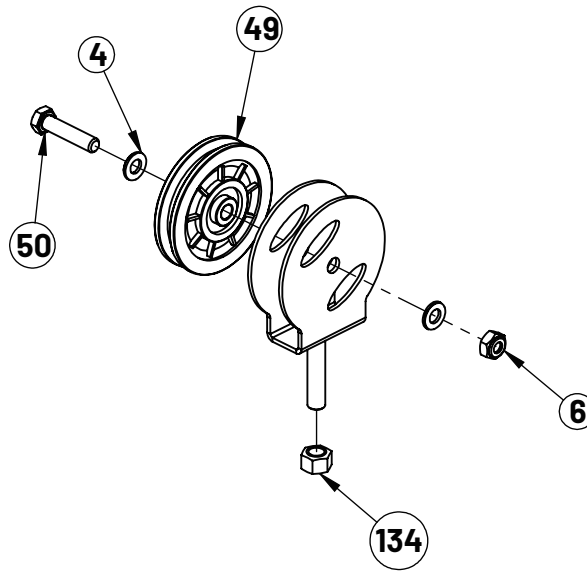

Key No.	Description	Note	Quantity
4	Flat Washer	φ10	2
6	Lock Nut	M10	1
49	Medium Pulley	φ92	1
50	Hexagon Bolt	M10×45	1
134	Hexagon Nut	M12	1

# EXPLODED DIAGRAMS

46.Weight Stack Pulley Frame, 2 pcs

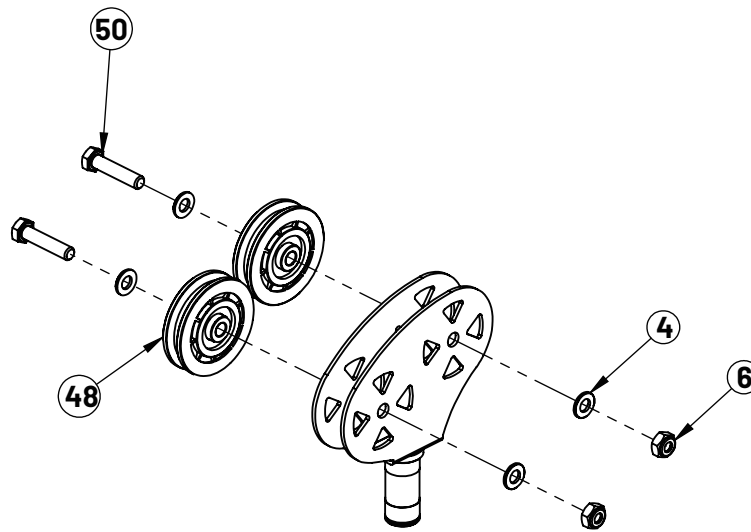

Key No.	Description	Note	Quantity
4	Flat Washer	φ10	4
6	Lock Nut	M10	2
48	Pulley	φ75	2
50	Hexagon Bolt	M10×45	2

27.Front Upper Frame - Right, 1 pc

28.Front Upper Frame - Left, 1 pc

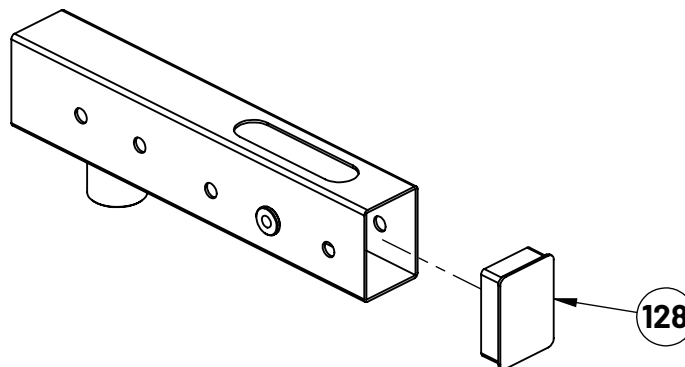

Key No.	Description	Note	Quantity
128	Inner Plug	50*70*2	1

# EXPLODED DIAGRAMS

## 51. Floating Pulley Frame, 2 pcs

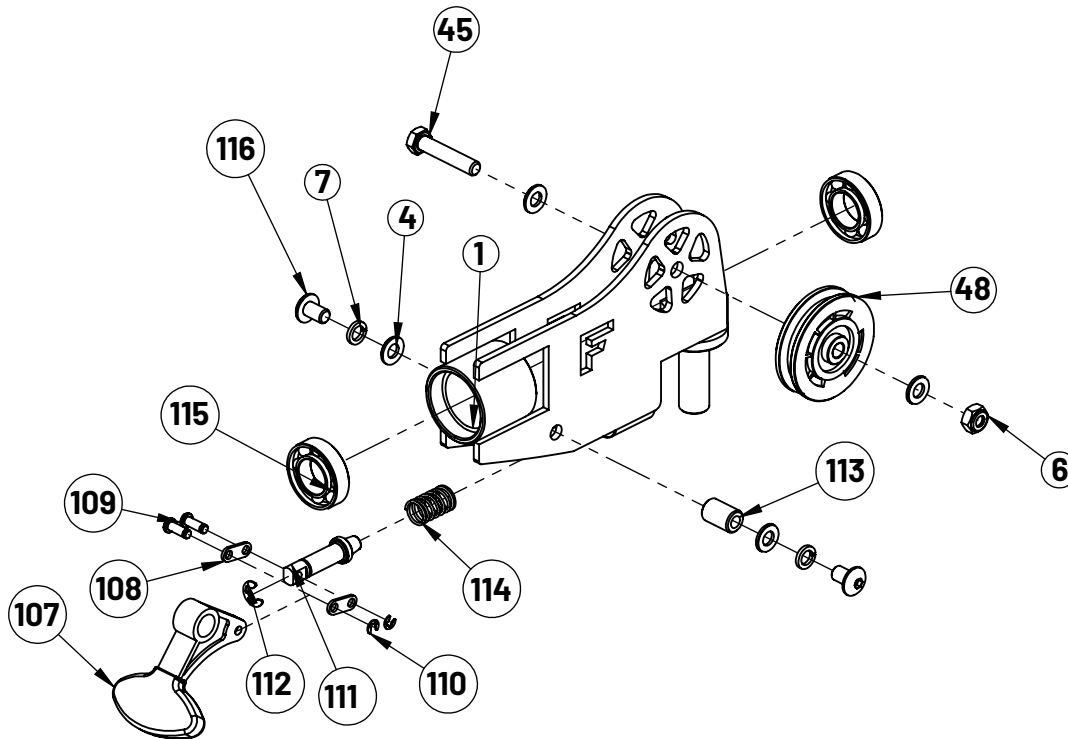

Key No.	Description	Note	Quantity
4	Flat Washer	$\phi 10$	4
6	Lock Nut	M10	1
7	Spring Washer	$\phi 10$	2
45	Hexagon Bolt	M10 $\times$ 50	1
48	Small Pulley	$\phi 75$	1
107	Grip Plate		1
108	Pull Pin Connection Plate Small	T2	2
109	Rotating Pin	$\phi 10^* \phi 6^* 18.5$	2
110	Mouth Open Stopper Collar	5	2
111	Gear Position Pull Pin	$\phi 21.7^* 63.5$	1
112	Mouth Open Stopper Collar	9	1
113	Inner Shaft	$\phi 15.9^* 24.5$ -M10	1
114	Pull Pin Spring	$\phi 16.2^* 1.6^* 45$	1
115	Bearing	6005	2
116	Inner Hexagon Flat Round Screw	M10 $\times$ 16	2

# EXPLODED DIAGRAMS

## 51. Floating Pulley Frame, 2 pcs

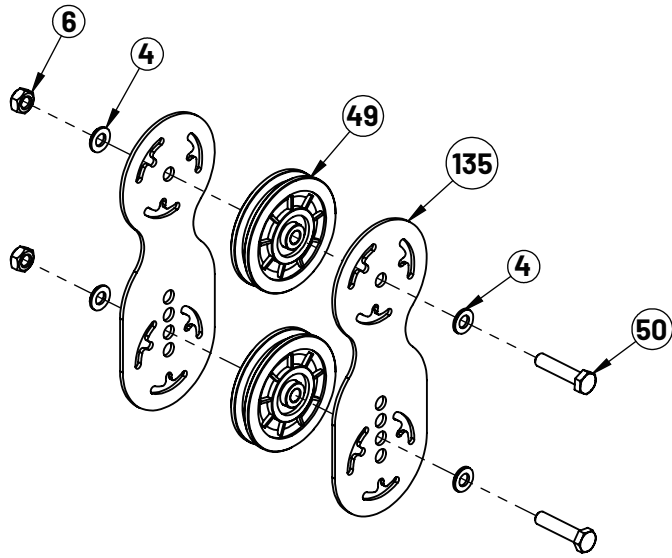

Key No.	Description	Note	Quantity
4	Flat Washer	φ10	4
6	Lock Nut	M10	2
49	Medium Pulley	φ92	2
50	Hexagon Bolt	M10×45	2
135	Pulley Adjusting Plate	T3	2

## 69. Accessory Hook, 7 pcs

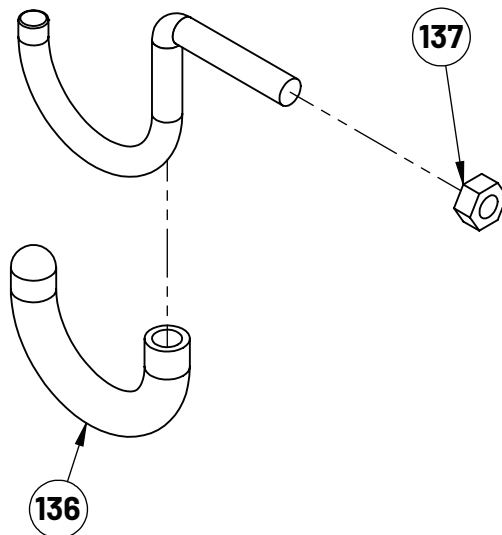

Key No.	Description	Note	Quantity
136	Hook Plastic Dip Handgrip	Φ8*100	1
137	Hexagon Screw	M8	1



# EXPLODED DIAGRAMS

91. Dual Cable Connector, 1 pc

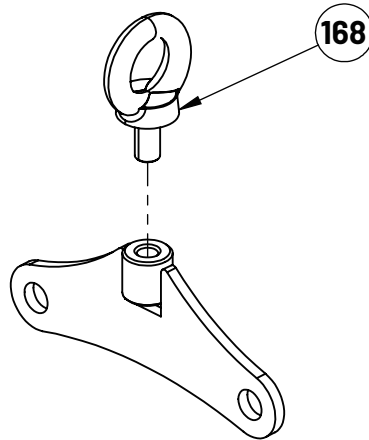

Key No.	Description	Note	Quantity
168	Hanging Ring Screw	M10	1

73. Smith Bar Olympic Sleeve, 2 pcs

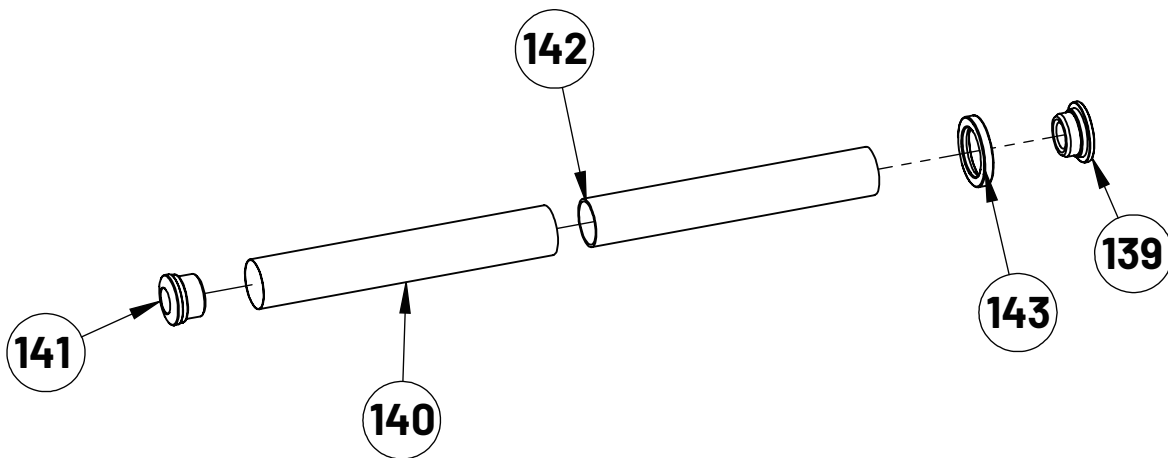

Key No.	Description	Note	Quantity
139	Inner Stopper Collar	$\phi 60 \times 27$	1
140	Outer Sleeve Tube	$\phi 49.5 \times 0.6$	1
141	Barbell Bar Stopper-Arc	$\phi 50 \times 37$	1
142	Barbell Bar Inner Sleeve Tube	$\phi 48 \times 2.5$	1
143	Rubber Stopper Collar	$\phi 70 \times \phi 50 \times \phi 10$	1

# EXPLODED DIAGRAMS

74J Hook Left, 1 pc  
75.J Hook Right, 1 pc

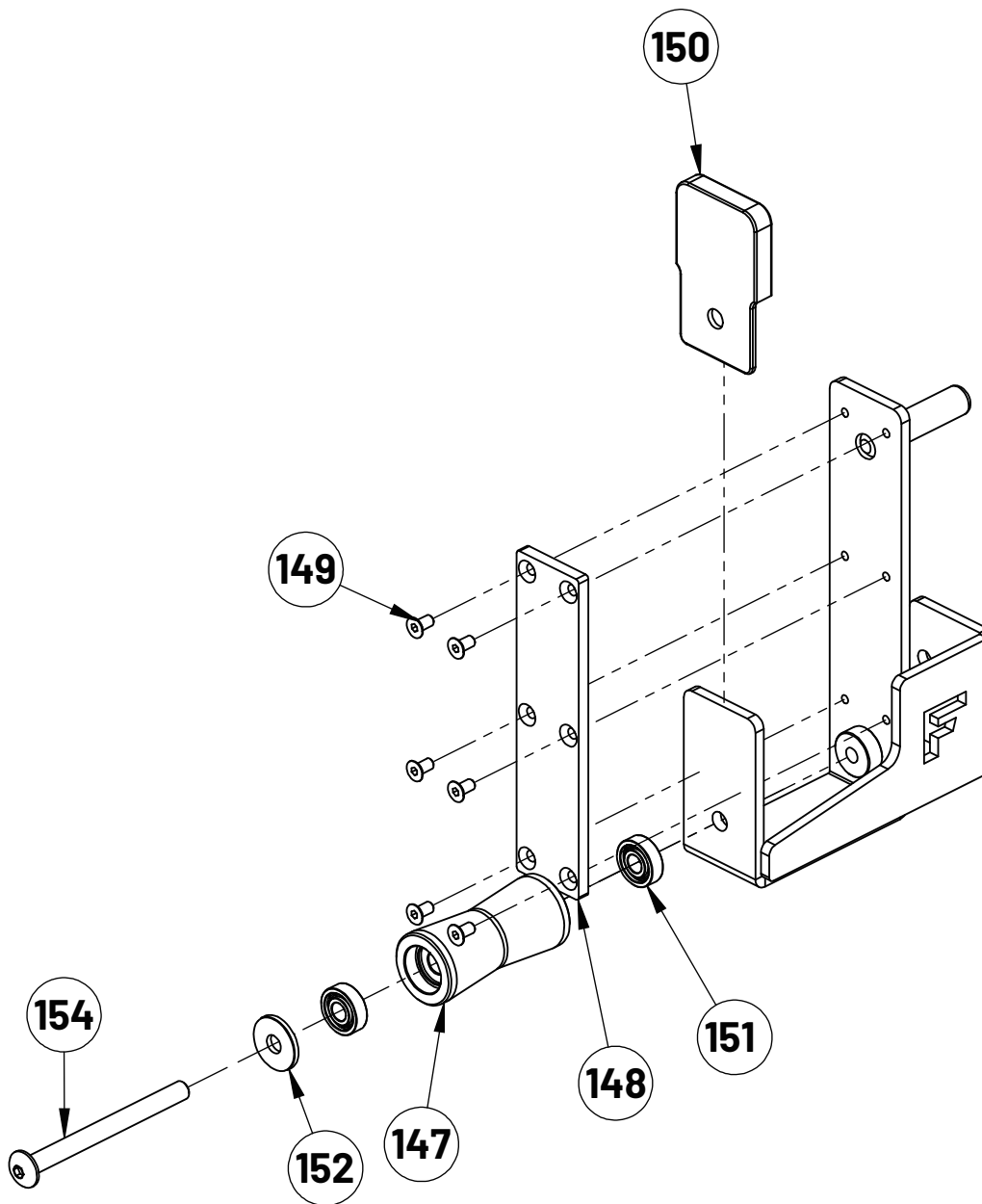

Key No.	Description	Note	Quantity
147	J-hook Roller	$\phi 40 \times 88$	1
148	Safety Spotter Rubber Sheet	$\phi 190 \times 45 \times 7$	1
149	Inner Hexagon Countersunk Screw	M6×12	6
150	J-hook Front Rubber Sheet	12.3×96	1
151	Deep Groove Ball Bearing	6000	2
152	Big Flat Washer	$\phi 30 \times \phi 10 \times 3$	1
154	Inner Hexagon Flat Round Screw	M10×115	1

# EXPLODED DIAGRAMS

- 76.Front Safety - Left, 1 pc
- 77.Front Safety - Right, 1 pc

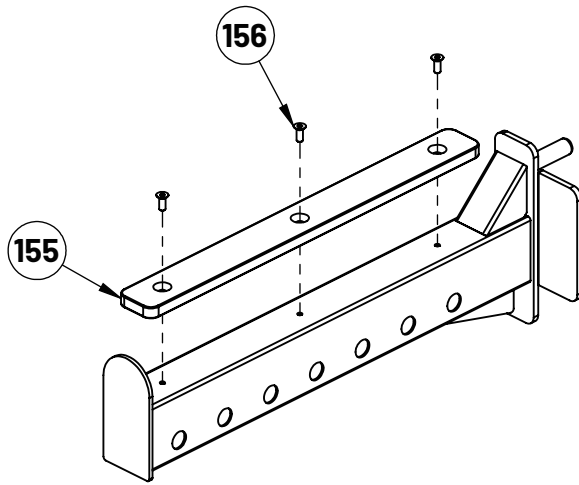

Key No.	Description	Note	Quantity
155	Safety Spotter Rubber Sheet	T12	1
156	Inner Hexagon Countersunk Screw	M6×16	3

- 89.Core Trainer Handle, 1 pc

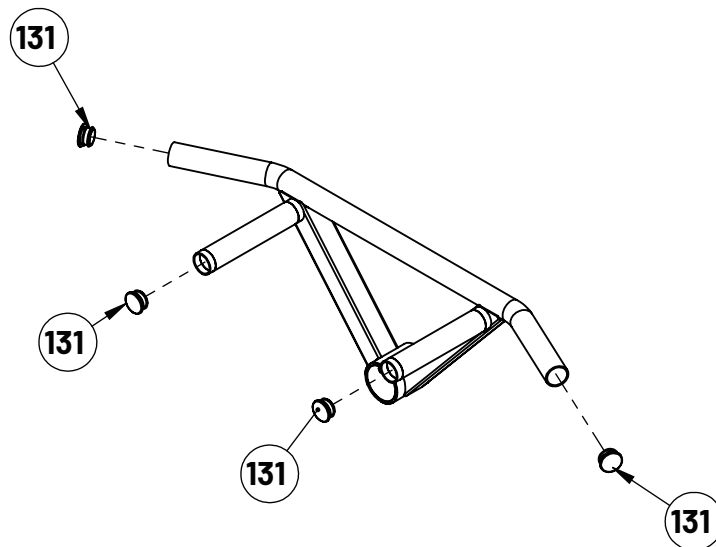

Key No.	Description	Note	Quantity
131	Round Tube Plug	φ32×1.5	4

# EXPLODED DIAGRAMS

80.Core Trainer, 1 pc

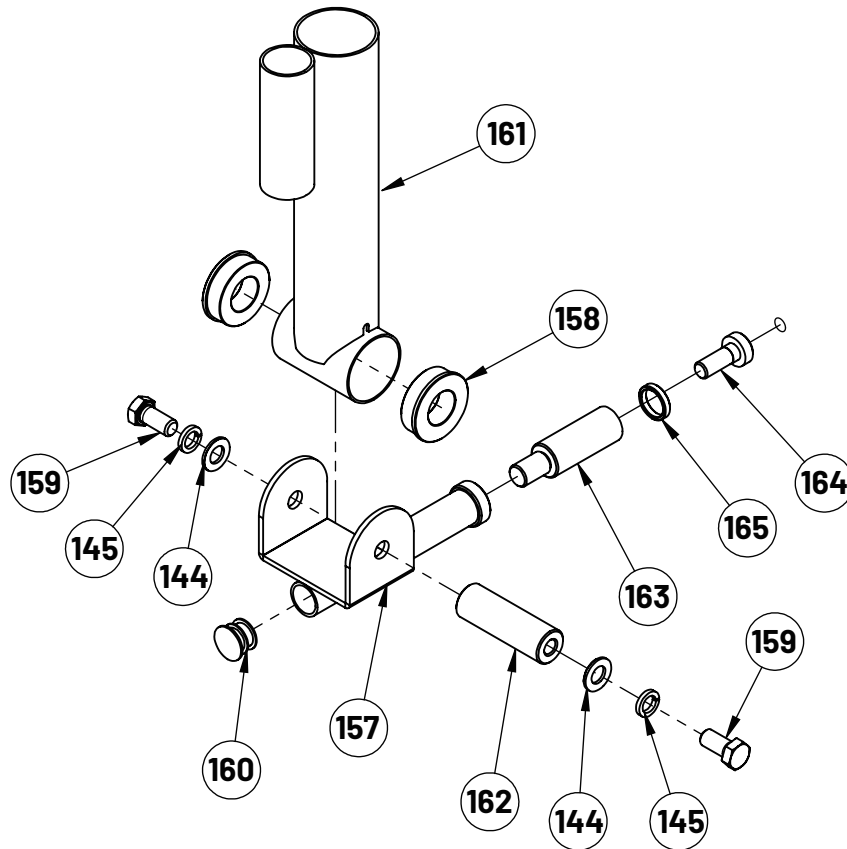

Key No.	Description	Note	Quantity
144	Flat Washer	φ12	2
145	Spring Washer	φ12	2
157	Core Trainer New Weldment		1
158	Powder Sleeve	φ50×φ47×φ25×15	2
159	Hexagon Bolt	M12×25	2
160	Round Tube Inner Plug	Φ25×2	1
161	Double Barbell Rotater		1
162	Inner Shaft	φ25*77*M12	1
163	Barbell Bar Plug	φ25*86	1
164	Limit Shaft	φ22*39.5	1
165	Limit Ring	φ25*φ20*5	1

# EXPLODED DIAGRAMS

87.Connection Bar - EZ Curl, 1 pc

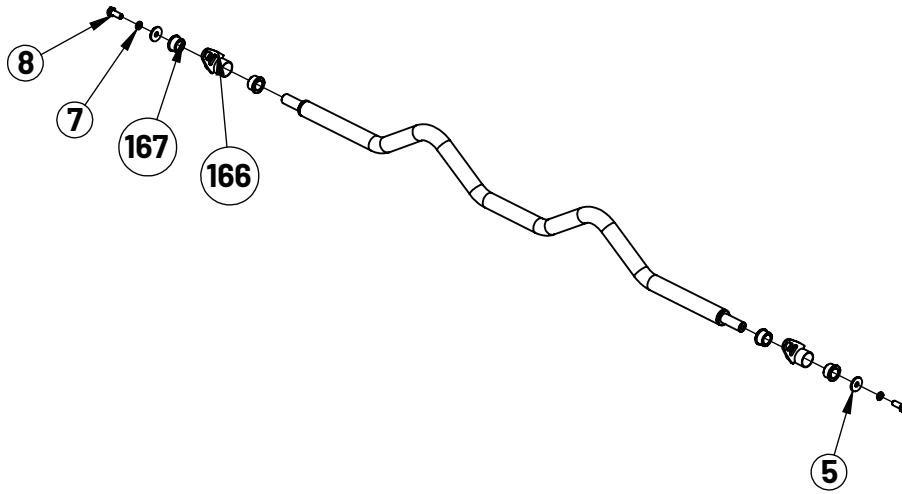

Key No.	Description	Note	Quantity
5	Big Flat Washer	$\phi 30 * \phi 10 * 3$	2
7	Spring Washer	$\phi 10$	2
8	Hexagon Bolt	M10×25	2
166	Straight Bar Rotater		2
167	Powder Sleeve	$\phi 33 * \phi 29 * \phi 20 * 18$	4

90.Lat Pull Down Bar, 1 pc

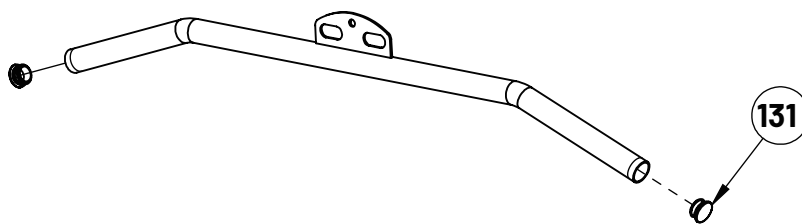

Key No.	Description	Note	Quantity
131	Round Tube Plug	$\phi 32 * 1.5$	2

# COMPLETE COMPONENT INVENTORY

Key No.	Description	Note	Quantity
1	Base Frame - Right		1
2	Base Linking Frame		1
3	Base Frame - Left		1
4	Flat Washer	φ10	186
5	Big Flat Washer	φ30*φ10*3	20
6	Lock Nut	M10	84
7	Spring Washer	φ10	68
8	Hexagon Bolt	M10x25	54
9	Hexagon Bolt	M10x100	4
10	Barbell Storage Holder		1
11	Upright Frame - Right		1
12	Upright Frame - Left		1
13	Upright Linking Frame - Middle		1
14	Upright Linking Frame - Upper		1
15	Upright Linking Frame - Lower		1
16	Front Guide Tube		2
17	Pulley Slider - Right		1
18	Pulley Slider - Left		1
19	Guide Rod - Smith Bar	φ25*2021	2
20	Rubber Bumper- Smith Bar	φ60xφ26x45	2
21	Smith Bar		1
22	Rubber Bumper- Pulley Slider	φ48xφ25.5x42	2
23	Smith Bar Guide Rod Fixing Sleeve	φ40*φ25.5*35	2
24	Grub Screw	M8*10	2
25	Upper Cover Plate - Outside	T5	2
26	Upper Cover Plate - Inside Right		1
27	Front Upper Frame - Right		1
28	Front Upper Frame - Left	Assembly Part	1
29	Upper Cover Plate - Inside Left		1
30	Hexagon Bolt	M10x75	16
31	Multi Grip Pull Up Bar		1
32	Pulley Frame		4
33	Pulley Frame Cover Plate	φ50xφ19xφ11	4
34	Hexagon Bolt	M10x25	6
35	Hexagon Bolt	M10x80	8
36	Smith Bar Racking Frame - Right		1
37	Smith Bar Racking Frame - Left		1
38	Hexagon Bolt	M10x110	4
39	Hexagon Bolt	M10x20	4
40	Weight Stack Guide Rod		4
41	Rubber Bumper - Weight Stack	φ60xφ27x42	4
42	Weight Stack	100KG	2
43	Selector Rod	φ25	2

# COMPLETE COMPONENT INVENTORY

Key No.	Description	Note	Quantity
*	*	*	*
45	Hexagon Bolt	M10x50	10
46	Weight Stack Pulley Frame		2
47	Weight Stack Selector Pin	φ10x100	2
48	Small Pulley	φ75	20
49	Medium Pulley	φ92	20
50	Hexagon Bolt	M10x45	24
51	Floating Pulley Frame		2
52	Large Pulley	φ127	2
53	Small Bushing	φ20xφ16xφ10.5x 15	22
54	Large Bushing	φ20*φ16*φ10.5*20.5	4
55	Hexagon Bolt	M10x65	10
56	Pulley Cover	T3	4
57	Front and Upper Pull Cable	13690mm	2
58	Rear Pull Cable Floating Pulley		2
59	Pulley Cable Guide	T4	2
60	Smith Bar Cable	2415mm	2
61	Olympic Weight Plate Holder		2
62	Rear Pull Cable	1620mm	2
63	Weight Stack Shield - Right	T1	1
64	Weight Stack Shield - Left	T1	1
65	Flat Washer	φ8	18
66	Spring Washer	φ8	12
67	Hexagon Bolt	M8x20	16
68	Accessory Hook Plate	T3	1
69	Accessory Hook		7
70	Low Row Footplate		1
*	*	*	*
72	Logo Board	T2	1
73	Smith Bar Olympic Sleeve		2
74	J Hook Left		1
75	J Hook Right		1
76	Front Safety - Left		1
77	Front Safety - Right		1
78	Olympic Quick Lock Collar	φ85Xφ50XH49	2
79	J Hook Flat Shock Pad		2
80	Landmine/Core Trainer		1
81	Single Stirrup - Nylon		2
82	Connection Bar - Straight		1
83	Extension Chain		4
84	Ankle Cuff	Leather	1
85	Tricep Rope	φ28*690	1
86	Close Grip Triangle		1

Olympic S

# COMPLETE COMPONENT INVENTORY

Key No.	Description	Note	Quantity
87	Connection Bar - EZ Curl		1
88	Bodyweight Assist Strap		1
89	Core Trainer Handle		1
90	Lat Pull Down Bar		1
91	Dual Cable Connector		1
92	Countersunk Head Hexagon Rivet Screw	M10	44
93	Deep Ball Bearing	6004	12
94	Hexagon Rivet Screw	M8	23
95	Square Tube Inner Plug	φ50×50×2	2
96	Pull Pin	φ12	2
97	Reducer Sleeve	F50-70/F40-60	1
98	Nylon Guide Sleeve	φ50*φ26.5*35	4
99	Handgrip Tube	φ25*2	2
100	Umbrella Pull Pin	φ12×M20×40-φ16	2
101	Decorative Cover	φ50×φ24×φ19×φ11	2
102	Bushing	50-60	4
103	Two Layer Spring Slice Screw	φ23-M10	4
104	Decorative Plate	T0.3	2
105	Cross Recessed Coiled Head Bolt	M4×8	8
106	Spring Stopper Collar	φ25	2
107	Grip Plate		2
108	Pull Pin Connection Plate Small	T2	4
109	Rotating Pin	φ10*φ6*18.5	4
110	Mouth Open Stopper Collar	5	4
111	Gear Position Pull Pin	φ21.7*63.5	2
112	Mouth Open Stopper Collar	9	2
113	Inner Shaft	φ15.9*24.5-M10	2
114	Pull Pin Spring	φ16.2*1.6*45	2
115	Bearing	6005	4
116	Inner Hexagon Flat Round Screw	M10×16	4
117	Barbell Inner Rod	φ24.9*1254	1
118	Long Barbell Bar	φ30*1110	1
119	Inner Hexagon Round Screw	M10×20	2
120	Rotating Plate Right		1
121	Nylon Hook Sleeve	φ19	2
122	Rotating Plate Left		1
123	Decorative Cover	φ11*φ17*φ30*φ45	2
124	Inner Hexagon Flat Round Screw	M10×16	2
125	Inner Hexagon Flat Round Screw	M10×50	2
126	Spring Washer	φ6	4
127	Inner Hexagon Flat Round Screw	M6×16	4
128	Inner Plug	50*70*2	2
129	50 surface Hook Ring		1

g Collar



# COMPLETE COMPONENT INVENTORY

Key No.	Description	Note	Quantity
130	Lock Nut	M8	2
131	Round Tube Plug	φ32×1.5	12
132	Pulley	φ50	4
133	Three Layer Spring Slice Screw	φ24.8-M10	8
134	Hexagon Nut	M12	2
135	Pulley Adjusting Plate	T3	4
136	Hook Plastic Dip Handgrip	φ8*100	7
137	Hexagon Screw	M8	7
138	Outer Barbell Bar Weldment		2
139	Inner Stopper Collar	φ60*27	2
140	Outer Sleeve Tube	φ49.5*0.6	2
141	Barbell Bar Stopper-Arc	φ50*37	2
142	Barbell Bar Inner Sleeve Tube	φ48*2.5	2
143	Rubber Stopper Collar	φ70×φ50×φ10	2
144	Flat Washer	φ12	4
145	Spring Washer	φ12	4
146	Inner Hexagon Flat Round Screw	M12×40	2
147	J-hook Roller	φ40*88	2
148	Safety Spotter Rubber Sheet	φ190×45×7	2
149	Inner Hexagon Countersunk Screw	M6×12	12
150	J-hook Front Rubber Sheet	12.3*96	2
151	Deep Groove Ball Bearing	6000	4
152	Big Flat Washer	φ30*φ10*3	2
153	Spring Washer	φ10	2
154	Inner Hexagon Flat Round Screw	M10×115	2
155	Safety Spotter Rubber Sheet	T12	2
156	Inner Hexagon Countersunk Screw	M6×16	6
157	Core Trainer New Weldment		1
158	Powder Sleeve	φ50×φ47×φ25×15	2
159	Hexagon Bolt	M12×25	2
160	Round Tube Inner Plug	Φ25×2	1
161	Double Barbell Rotater		1
162	Inner Shaft	φ25*77*M12	1
163	Barbell Bar Plug	φ25*86	1
164	Limit Shaft	φ25*86	1
165	Limit Ring	φ25*86	1
166	Straight Bar Rotater		2
167	Powder Sleeve	φ25*86	4
168	Hanging Ring Screw	φ25*86	1
169	Hexagon Socket Button Head Screw	φ25*86	8
170	Foam Pad	700mm	1
171	Lock Nut	M12	2
*	*	*	*

# WARRANTY INFO

---

For warranty information please contact the dealer nearest to you.



<https://www.forceusa.com/locator>

**FORCE** **USA**

[forceusa.com](http://forceusa.com)