

FORCE USA

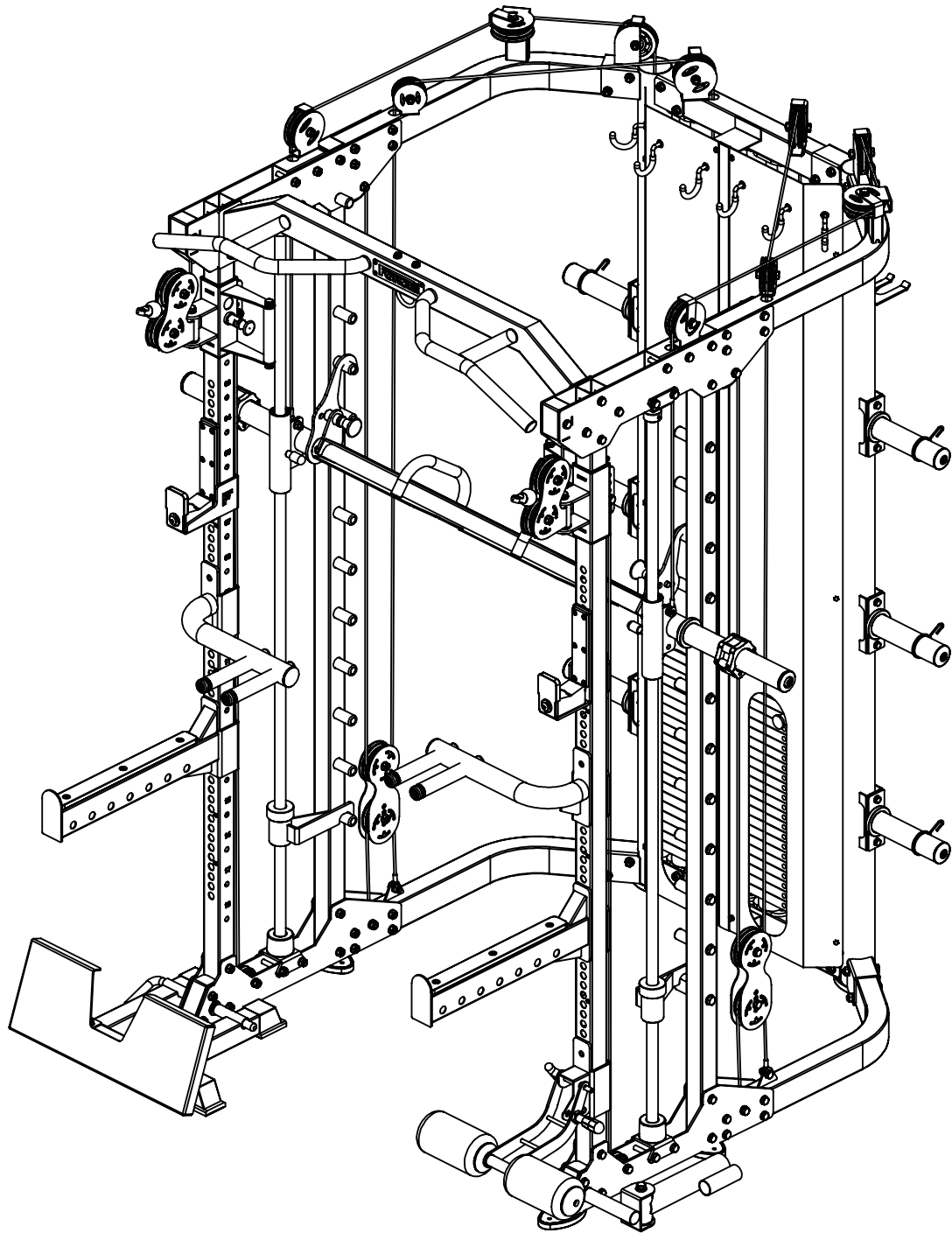

USER MANUAL | **F-G12-V2**





THANK YOU FOR YOUR PURCHASE

**For the most up to date info about using
your equipment and our latest support
videos, please visit:**

www.forceusa.com





TRAINING APP

Download now and get access to 400+ exercise tutorials, absolutely free!



DOWNLOAD THE APP



STAY FOCUSED

Enjoy a low-friction interface designed to keep you focused on your next set.

NEW WORKOUT PLANS

Loaded with a growing library of unique workouts. Hundreds of movement tutorials designed by our expert panel of coaches.

REWARD YOUR SUCCESS

See your results build after every session with the pyramid progress tracker. Feel the support and share your progress with family and friends.

HARDER IS GOOD SMARTER IS BETTER

The Force USA Training App offers customized workout plans so that you can get the same results in half the time.

Learn more at app.forceusa.com



BEFORE YOU START



Read all instructions in this manual before assembling or using this equipment



Only tighten nuts and bolts loosely until all equipment is assembled. Once the equipment is fully assembled, tighten from the bottom up, working evenly around the unit.

- Remove all parts from the packaging and count each component separately to ensure everything is provided correctly, noting that some items may be pre-assembled
- Follow the instructions and refer to both the individual assembly pages and the exploded views of the equipment whenever possible
- The owner is responsible for ensuring that all users of this unit have read the user manual and understand the safety precautions
- Descriptions of left and right refer to the perspective of standing in front, facing the equipment.
- Place all parts in a cleared area and remove the packing materials. Do not dispose of the packing materials until all assembly steps are completed
- It is recommended to keep these instructions

Although current at the time of this printing, specifications for this model may have changed in our continuing effort for improvement. Force USA reserves the right to modify and improve the specifications of its products without prior notice.

BEFORE YOU START CONTINUED

SAFETY PRECAUTIONS

Every piece of Force USA equipment is built for maximum safety and meets or exceeds all applicable domestic and international standards. However, certain precautions must be taken when operating any piece of fitness equipment.

- It is highly recommended that two or more people are used for assembly
- Assemble equipment on a flat surface
- Consider placing a mat/mats under the equipment to protect your floor
- Ensure all parts are in working order prior to use
- Make sure all pivoting components are able to move freely
- Do not use or store the equipment outdoors or around water
- Do not over tighten any component with pivoting function
- Keep hair, fingers and clothing away from moving parts
- Only use attachments recommended by the manufacturer
- Never operate if parts are not functioning correctly
- Always stretch prior to using equipment
- Stop immediately if you experience any pain, dizziness or nausea
- Before starting any exercise program consult your doctor

PREVENTATIVE MAINTENANCE

To ensure your equipment is operating at its peak, please follow the below preventative maintenance schedule performing all tasks upon initial assembly:







Daily Maintenance

- Wipe down the equipment to remove any dust and sweat residue with a dry, non-abrasive cloth
- Inspect the unit for noisy, damaged or loose components





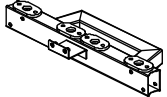
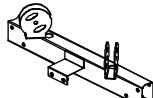
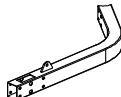
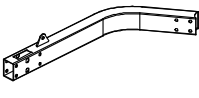
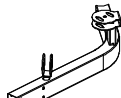
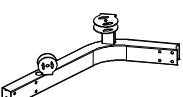

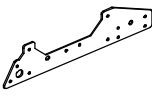

Monthly Maintenance

- Thoroughly clean the equipment using a non abrasive cloth dampened with a mild, all purpose cleaner ensuring to thoroughly wipe down and dry the equipment afterwards
- Apply a 100% silicone lubrication (preferably spray) to guide rods, pulley sliders, weight plate carriages and any other moving parts where friction can occur including bearings (where applicable). Any other form of lubrication will void your warranty
- Check the tightness of all bolts, nuts and screws
- Check the cables for fraying or any signs of wear and ensure they are at the correct tension with a small amount of slack at resting position (where applicable)
- Inspect pulleys for any damage or cracks (where applicable)
- Knurling can be cleaned using a soft bristled brush to help remove any particles that may be nestled within the knurling
- Vacuum around the machine/equipment to prevent dust acclumulation

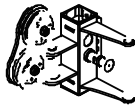

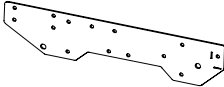

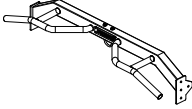

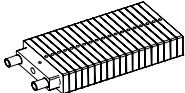
PARTS & HARDWARE IDENTIFIER

Key No.	Description	Quantity	Parts Schematic Diagram
1	Upright Frame - Right	1	
2	Upright Frame - Left	1	
3	Smith Bar Counterbalance	2	
4	Counterbalance Cable	2	
5	Rear Lower Connection Frame	1	
6	Rear Upper Connection Frame	1	
10	Base Bending Frame - Left	1	
11	Base Bending Frame - Right	1	
12	Upper Bending Frame - Right	1	
13	Upper Bending Frame - Left	1	
14	Foot Tube Cover	2	
15	Lower Pulley Cover	4	

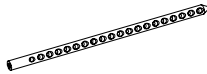

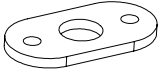
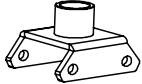

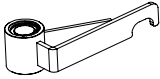
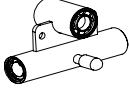
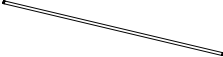

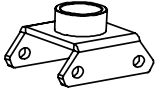
PARTS & HARDWARE IDENTIFIER

Key No.	Description	Quantity	Parts Schematic Diagram
16	Smith Bar Racking Frame	2	
17	Front Guide Tube - Right	2	
18	Front Guide Tube - Left	2	
19	Pulley Slider - Left	1	
20	Pulley Slider - Right	1	
21	Upper Pulley Cover	4	
22	Upper Pulley End Tube	2	
23	Top Smith Bar Hook	2	
24	Chin Up Frame	1	
26	Guide Rod	4	
27	Rubber Bumper - Smith Bar	2	
28	Weight Stack (Includes Top Weight Plate)	2	

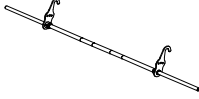
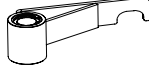
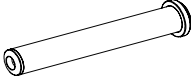
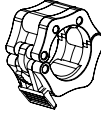

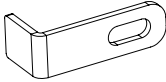
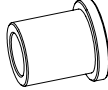

PARTS & HARDWARE IDENTIFIER

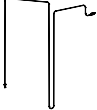
Key No.	Description	Quantity	Parts Schematic Diagram
29	Weight Stack Pin Selector Rod	2	
30	Selector Rod Locking Pin (Pre Assembled)	2	
31	Weight Selector Pin	2	
32	Weight Stack Reinforcing Plate	4	
34	Smith Bar Lower Connecting Sleeve	2	
35	Large Rubber Bumper - Smith Bar	2	
36	Small Rubber Bumper - Smith Bar	2	
37	Safety Hook Right	1	
38	Smith Bar Sliding Sleeve	2	
39	Guide Rod - Smith Bar	2	
40	Smith Bar Guide Rod Fixing Sleeve	2	
41	Smith Bar Upper Connecting Sleeve	2	



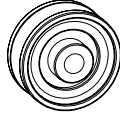
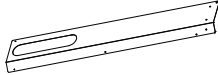
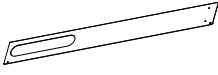

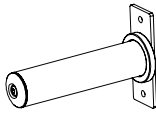
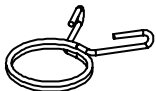
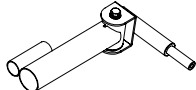

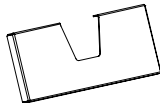
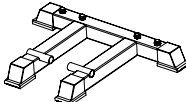

PARTS & HARDWARE IDENTIFIER

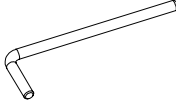
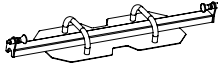
Key No.	Description	Quantity	Parts Schematic Diagram
44	Smith Bar	1	
45	Safety Hook Left	1	
46	Smith Bar Weight Plate Sleeve	2	
50	Olympic Quick Lock Collar	2	
51	Top Pulley Insert Right	1	
52	Top Pulley Insert Left	1	
53	Pulley (96mm)	12	
54	Cable Guide	8	
56	Metal Bushing	16	
57	Pulley (75mm)	2	
59	Floating Pulley Frame	2	
60	Weight Stack Cable	2	

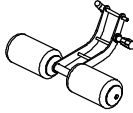
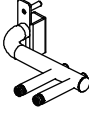

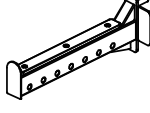
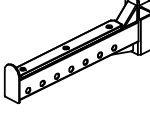
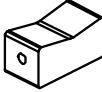

PARTS & HARDWARE IDENTIFIER

Key No.	Description	Quantity	Parts Schematic Diagram
61	Lower Pull Cable	2	
62	Pulley (50mm)	4	
63	Weight Stack Shield - Right	1	
64	Weight Stack Shield - Left	1	
65	Shield Connection Piece	1	
68	Accessory Hook	6	
71	Olympic Weight Plate Holder	6	
72	Olympic Spring Collar	6	
74	Core Trainer	1	
75	Metal Bushing	4	
77	Low Row Foot Plate	1	
78	Low Row Foot Plate Support Frame	1	

PARTS & HARDWARE IDENTIFIER

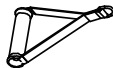
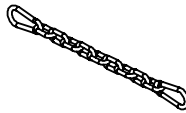
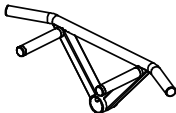
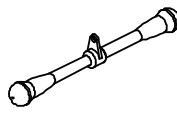
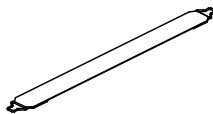
Key No.	Description	Quantity	Parts Schematic Diagram
79	Band Peg	1	
80	Leg Press Foot Plate	1	
81	Knee Stabilizer J Hook	1	
82	Knee Stabilizer	1	
83	Dip Handle - Left	1	
84	Dip Handle - Right	1	
85	J-hook - Left	1	
86	J-Hook - Right	1	
87	Front Safety - Left	1	
88	Front Safety - Right	1	
89	J-hook Block Insert	2	
90	Tricep Rope	1	

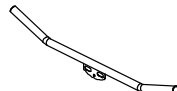
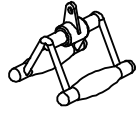
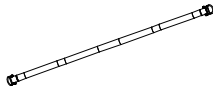
PARTS & HARDWARE IDENTIFIER

Key No.	Description	Quantity	Parts Schematic Diagram
91	Ankle Strap	1	
92	Single Stirrup - Nylon	2	
93	Extension Chain	2	
94	Core Trainer Handle	1	
95	Short Revolving Straight Bar	1	
96	Bodyweight Assist Strap	1	
97	Carabiner	2	
98	Lat Pulldown Bar	1	
99	Close Grip Triangle	1	
100	Connection Bar - Straight	1	
101	V-Bar	1	

PARTS & HARDWARE IDENTIFIER

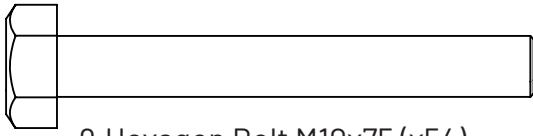

9.Hexagon Bolt M10x75 (x54)

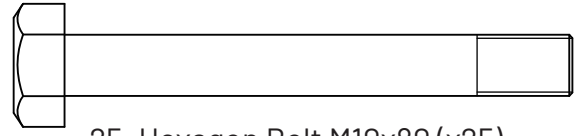

25. Hexagon Bolt M10x80 (x25)

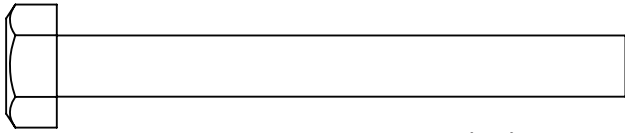

42.Hexagon Bolt M10x90 (x8)

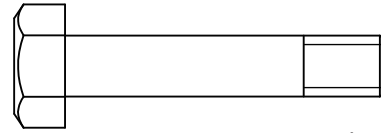

55.Hexagon Bolt M10x50 (x8)

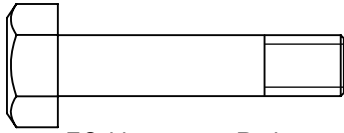

58.Hexagon Bolt M10x45 (x2)

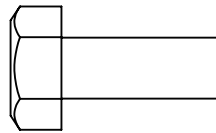

33.Hexagon Bolt M10x25 (x15)



8. Lock Nut M10 (x88)

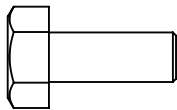

73.Hexagon Bolt M8x20 (x12)

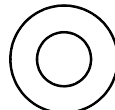

69. Flat Washer Φ8 (x6)



70. Lock Nut M8 (x6)

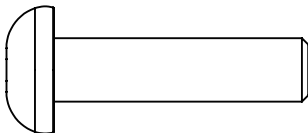

47.Hexagon Button Head Screw M12x40 (x2)

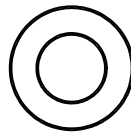

7. Flat Washer Φ10 (x2)

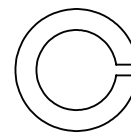

48. Spring Washer Φ12 (x2)

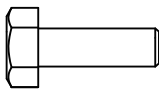

67.Hexagon Bolt M6x20 (x10)

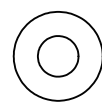

66. Flat Washer Φ6 (x10)



43. Grub Screw M8x10 (x2)

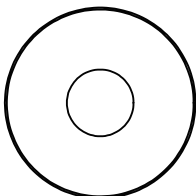

76. Big Flat Washer Φ30xΦ10.5x3.0 (x1)

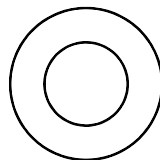

49. Flat Washer Φ12 (x2)

STEP 1 - ASSEMBLY

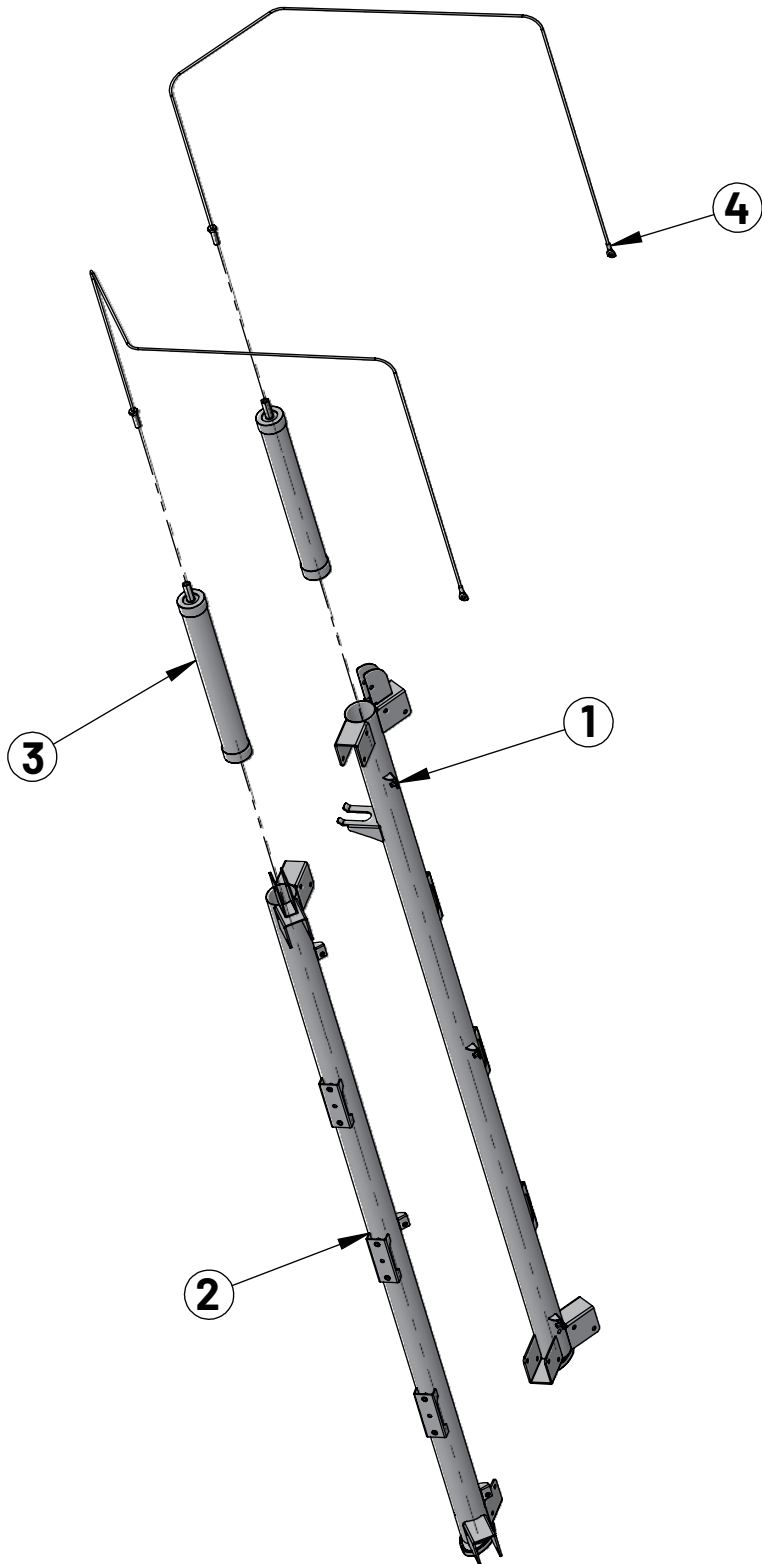

Key No.	Description	Note	Quantity
1	Upright Frame - Right		1
2	Upright Frame - Left		1
3	Smith Bar Counterbalance		2
4	Counterbalance Cable	$\phi 5 * 2935$	2

STEP 2 - ASSEMBLY

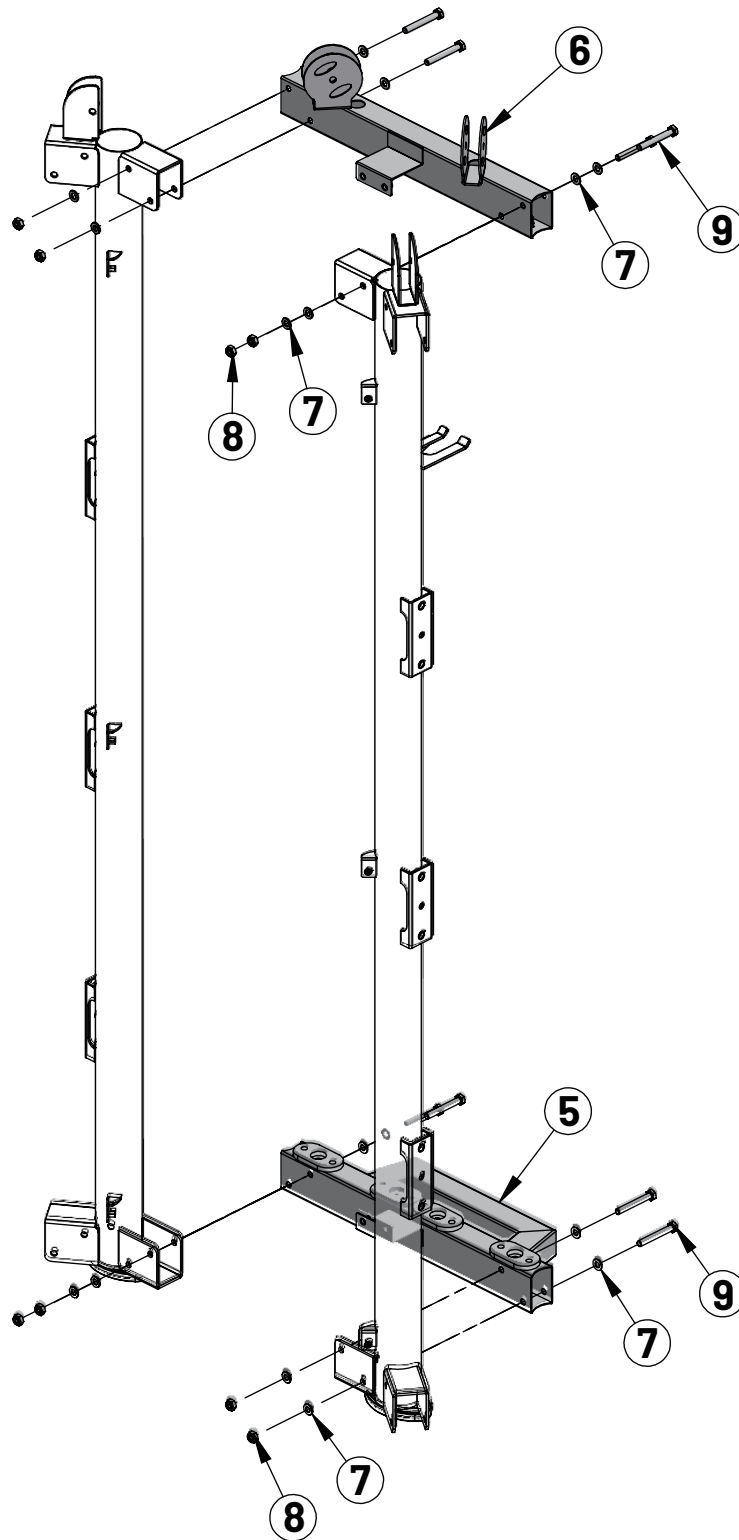

Key No.	Description	Note	Quantity
5	Rear Lower Connection Frame		1
6	Rear Upper Connection Frame		1
7	Flat Washer	$\phi 10$	16
8	Lock Nut	M10	8
9	Hexagon Bolt	M10×75	8

STEP 3 - ASSEMBLY

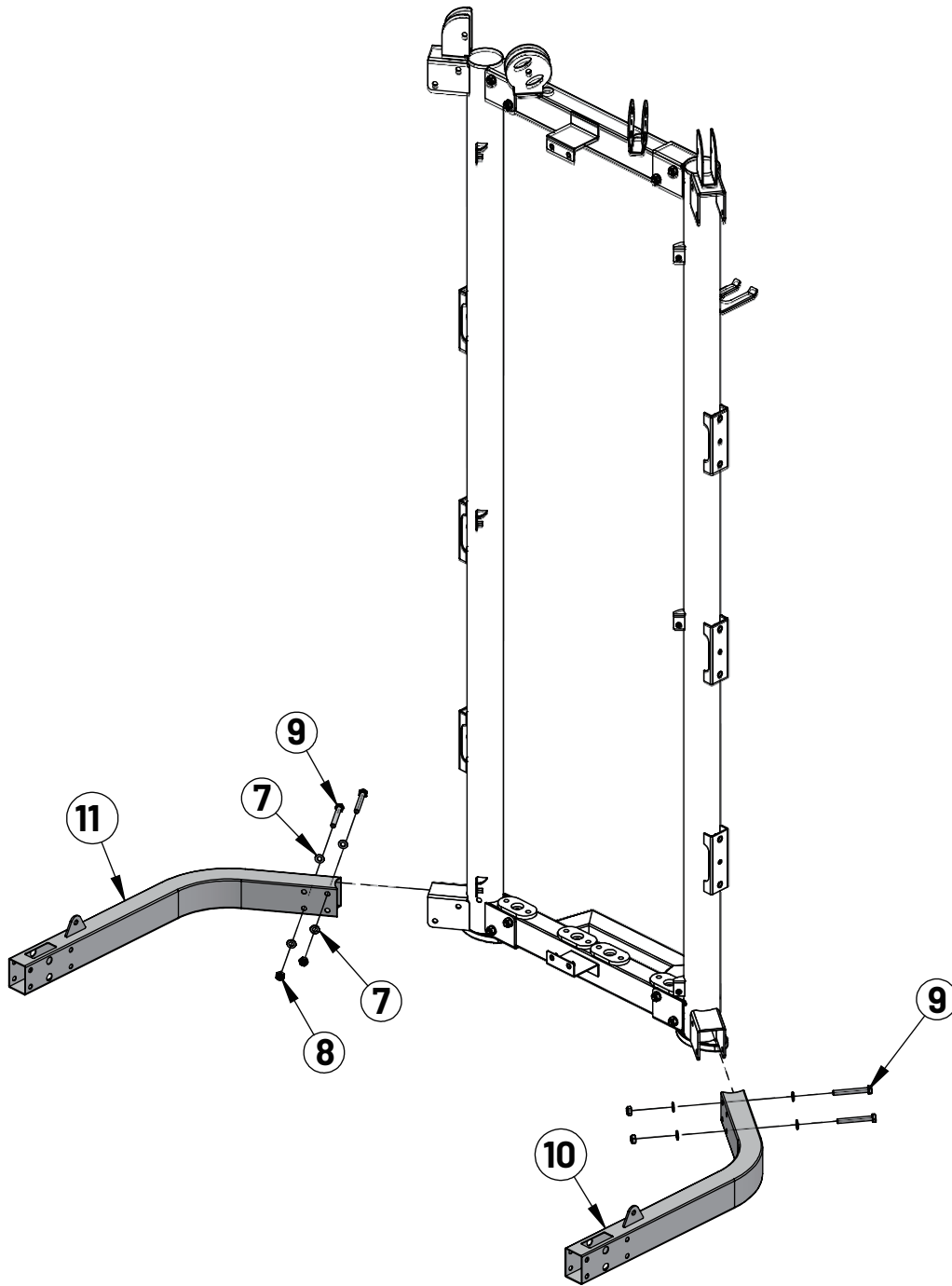

Key No.	Description	Note	Quantity
7	Flat Washer	φ10	8
8	Lock Nut	M10	4
9	Hexagon Bolt	M10×75	4
10	Base Bending Frame - Left		1
11	Base Bending Frame - Right		1

STEP 4 - ASSEMBLY

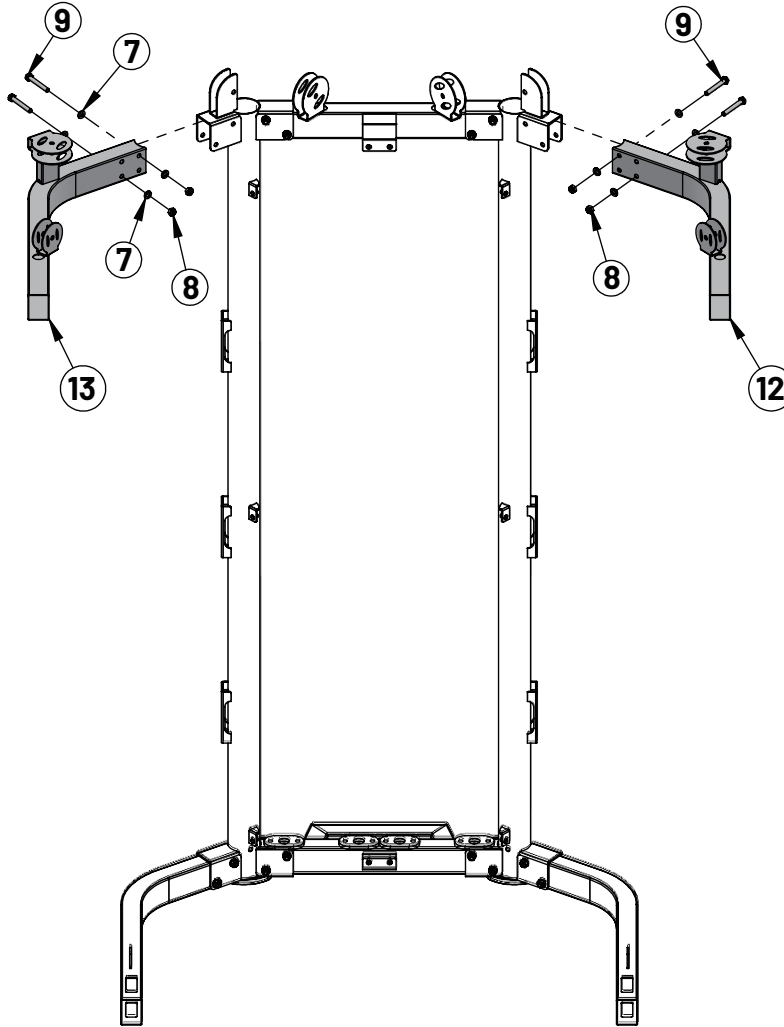

Key No.	Description	Note	Quantity
7	Flat Washer	φ10	8
8	Lock Nut	M10	4
9	Hexagon Bolt	M10×75	4
12	Upper Bending Frame - Right		1
13	Upper Bending Frame - Left		1

STEP 5 - ASSEMBLY

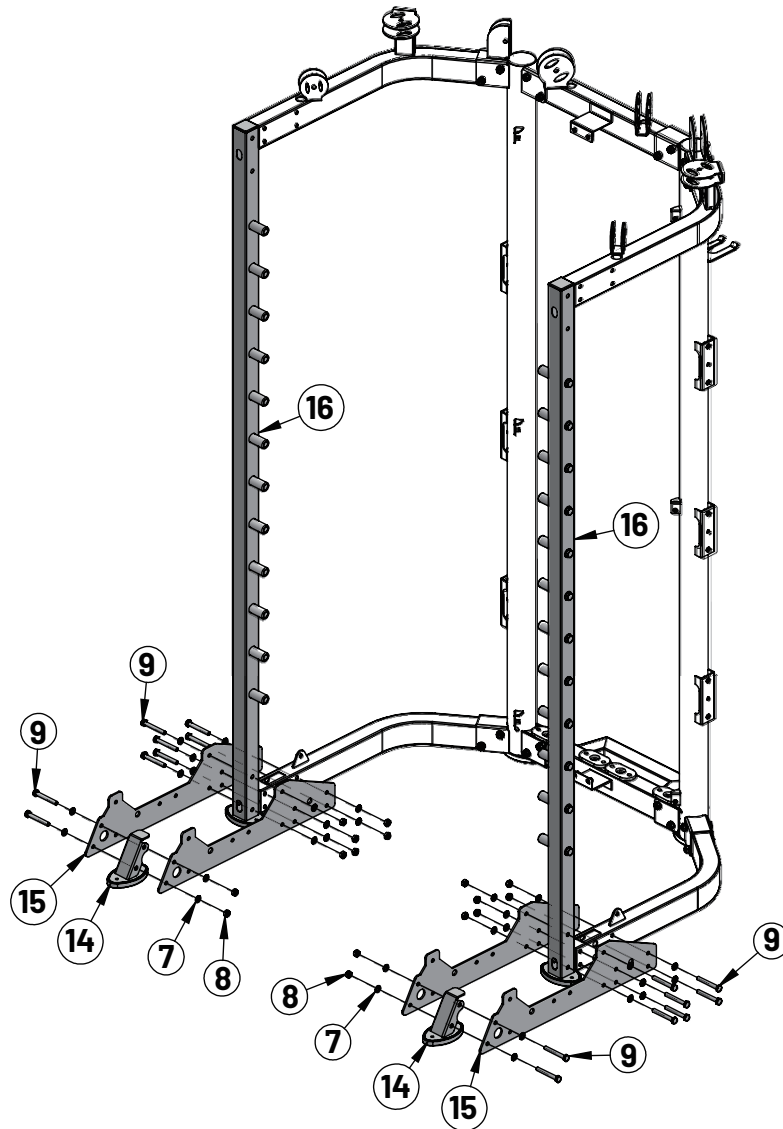

Key No.	Description	Note	Quantity
7	Flat Washer	φ10	32
8	Lock Nut	M10	16
9	Hexagon Bolt	M10×75	16
14	Foot Tube Cover		2
15	Lower Pulley Cover	T5	4
16	Smith Bar Racking Frame		2

STEP 6 - ASSEMBLY

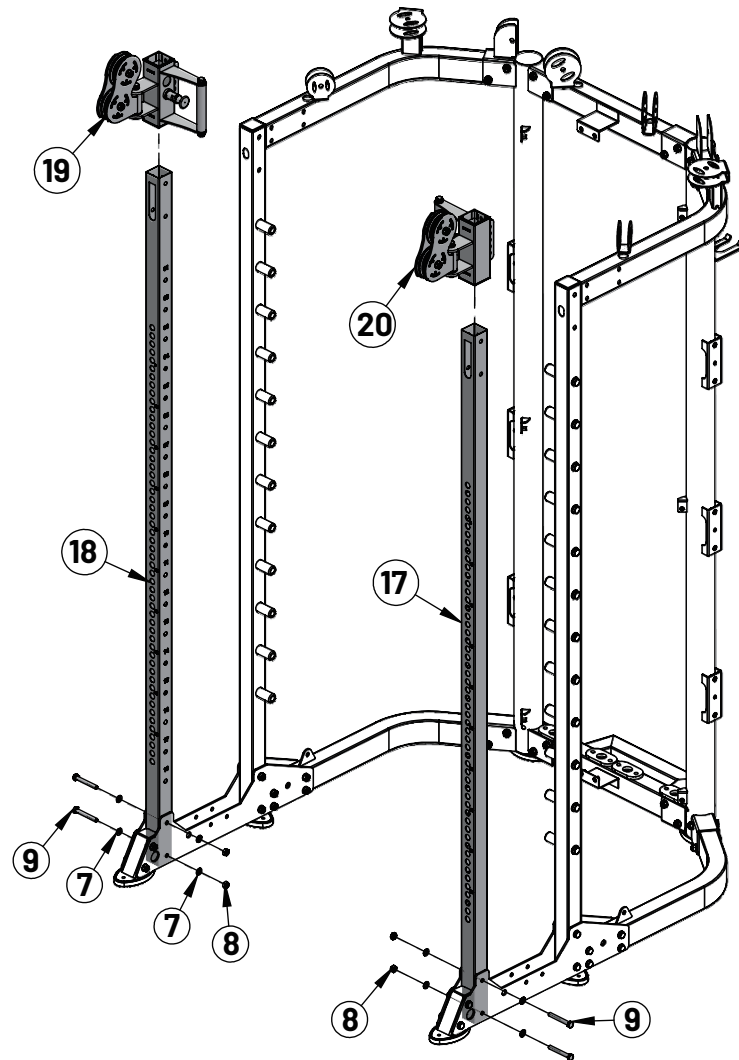

Key No.	Description	Note	Quantity
7	Flat Washer	φ10	8
8	Lock Nut	M10	4
9	Hexagon Bolt	M10×75	4
17	Front Guide Tube - Right	□50*50*2	1
18	Front Guide Tube - Left	□50*50*2	1
19	Pulley Slider - Left		1
20	Pulley Slider - Right		1

STEP 7 - ASSEMBLY

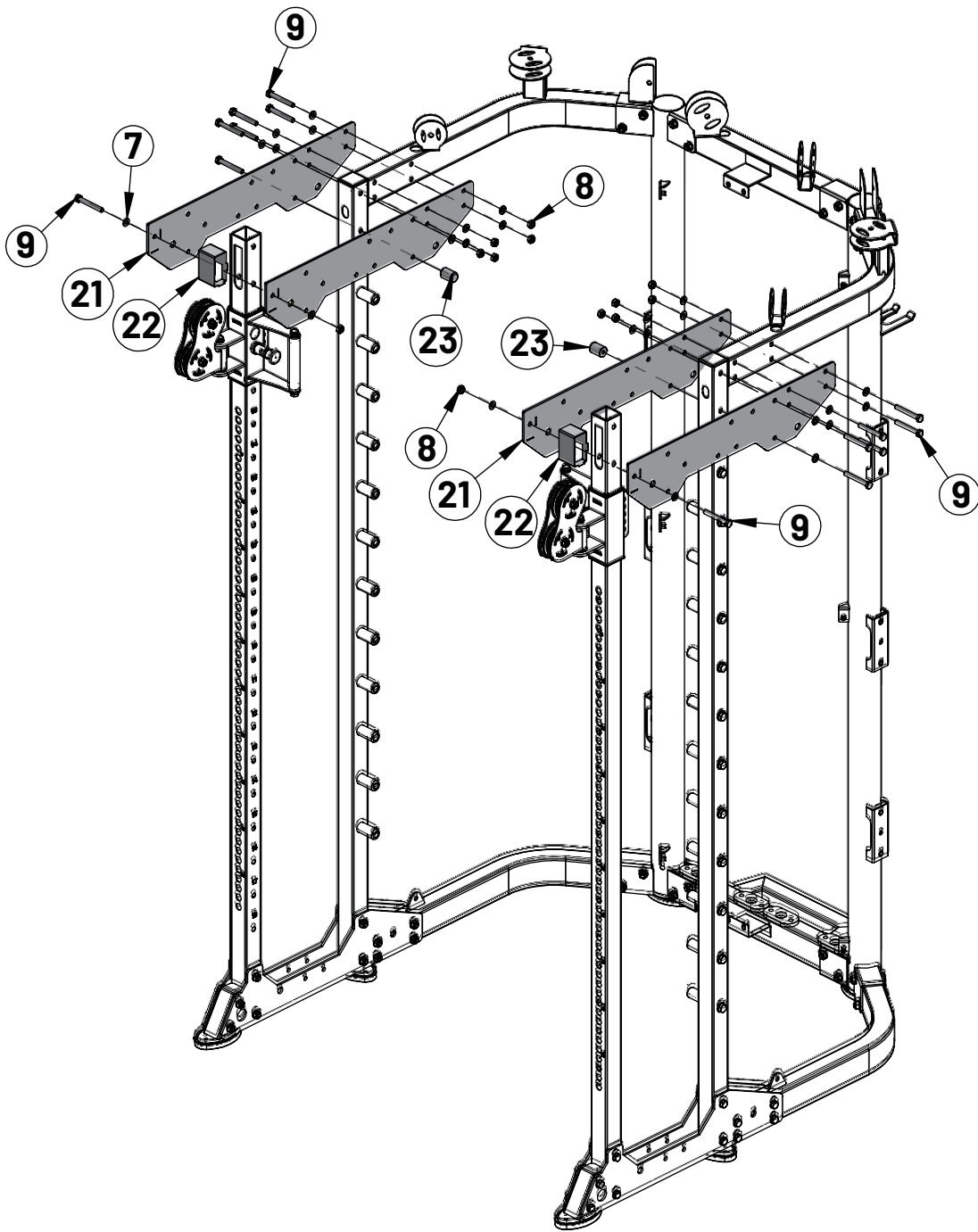

Key No.	Description	Note	Quantity
7	Flat Washer	φ10	26
8	Lock Nut	M10	12
9	Hexagon Bolt	M10×75	14
21	Upper Pulley Cover	T5	4
22	Upper Pulley End Tube	□40*80*1.5	2
23	Top Smith Bar Hook	φ25*35-M10	2

STEP 8 - ASSEMBLY

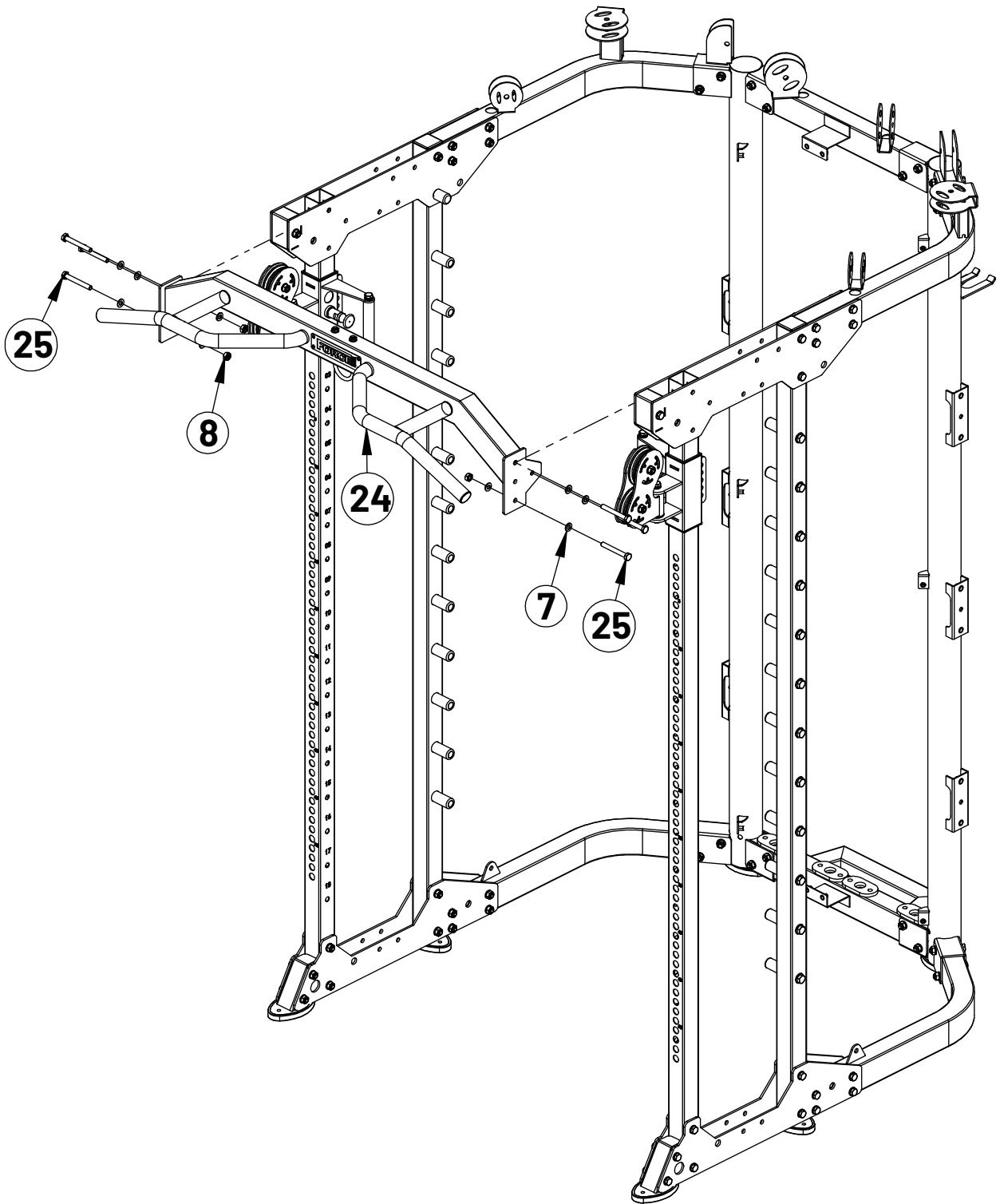

Key No.	Description	Note	Quantity
7	Flat Washer	$\phi 10$	10
8	Lock Nut	M10	4
24	Chin Up Frame		1
25	Hexagon Bolt	M10×80	6

STEP 9 - ASSEMBLY

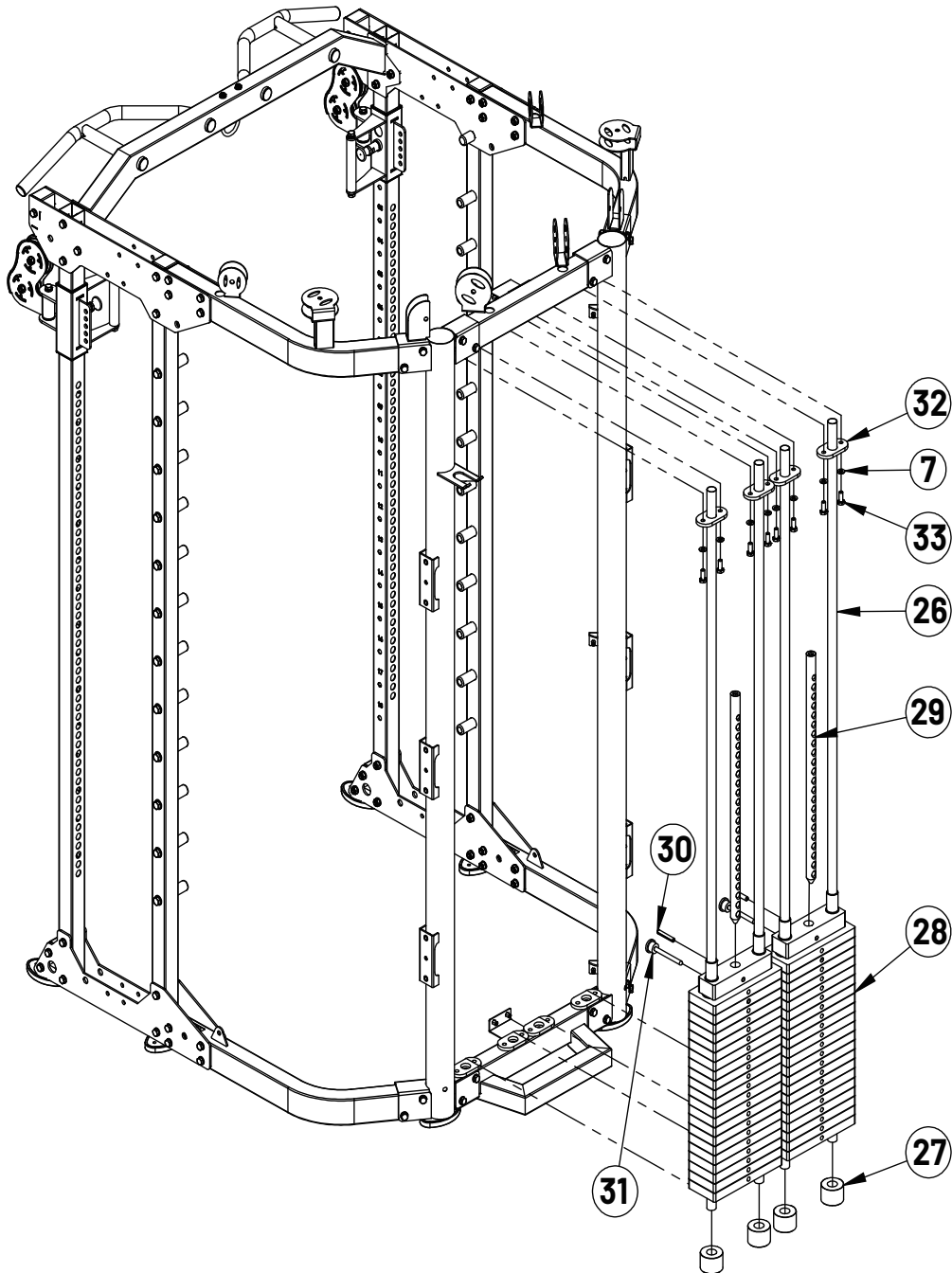

Key No.	Description	Note	Quantity
7	Flat Washer	$\phi 10$	8
26	Guide Rod	$\phi 25 \times 0.8$	4
27	Rubber Bumper - Smith Bar	$\phi 60 \times \phi 27 \times 42$	4
28	Weight Stack (Includes Top Weight Plate)	100KG	2
29	Weight Stack Pin Selector Rod (Pre Assembled)	$\phi 25$	2
30	Selector Rod Locking Pin (Pre Assembled)	10×60	2
31	Weight Selector Pin	$\phi 10 \times 100$	2
32	Weight Stack Reinforcing Plate	T8*95*50	4
33	Hexagon Bolt	M10×25	8

STEP 10 - ASSEMBLY

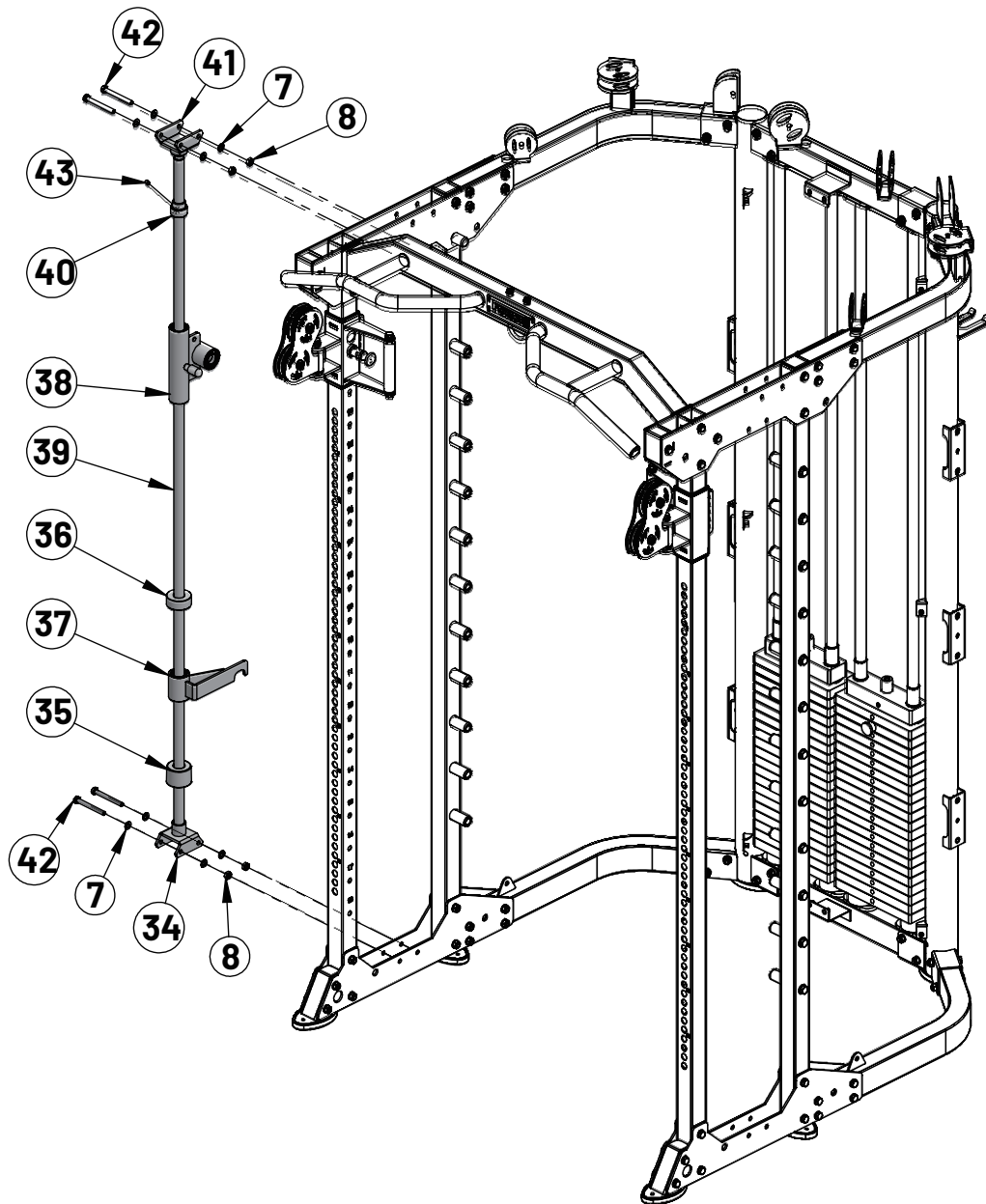

Key No.	Description	Note	Quantity
7	Flat Washer	φ10	8
8	Lock Nut	M10	4
34	Smith Bar Lower Connecting Sleeve		1
35	Large Rubber Bumper - Smith Bar	φ60×φ26×45	1
36	Small Rubber Bumper - Smith Bar	φ60×φ26×25	1
37	Safety Hook Right		1
38	Smith Bar Sliding Sleeve		1
39	Guide Rod - Smith Bar	φ25*1878	1
40	Smith Bar Guide Rod Fixing Sleeve	φ40*φ25.5*35	1
41	Smith Bar Upper Connecting Sleeve		1
42	Hexagon Bolt	M10×90	4
43	Grub Screw	M8*10	1

STEP 11 - ASSEMBLY

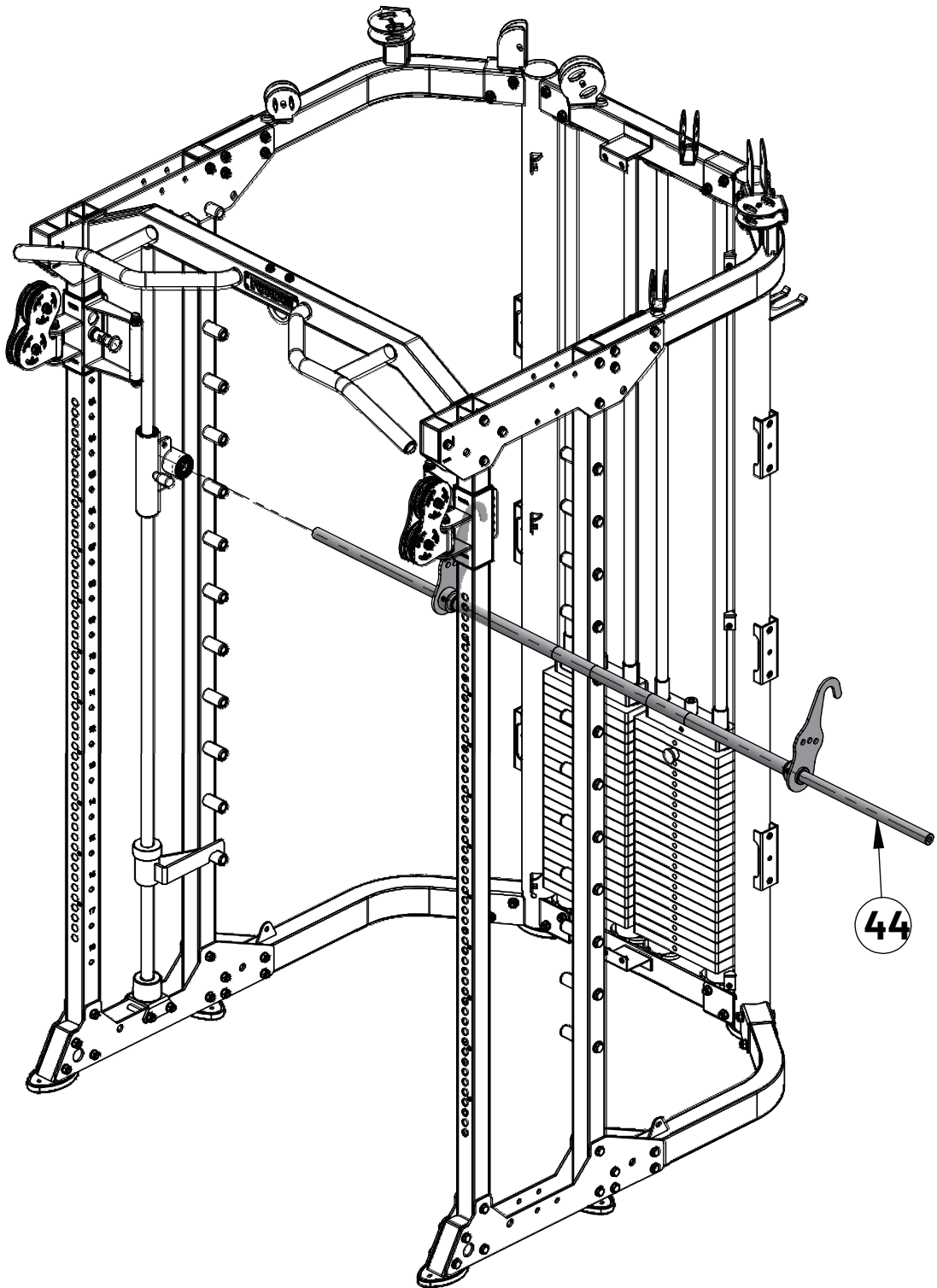

Key No.	Description	Note	Quantity
44	Smith Bar		1

STEP 12 - ASSEMBLY

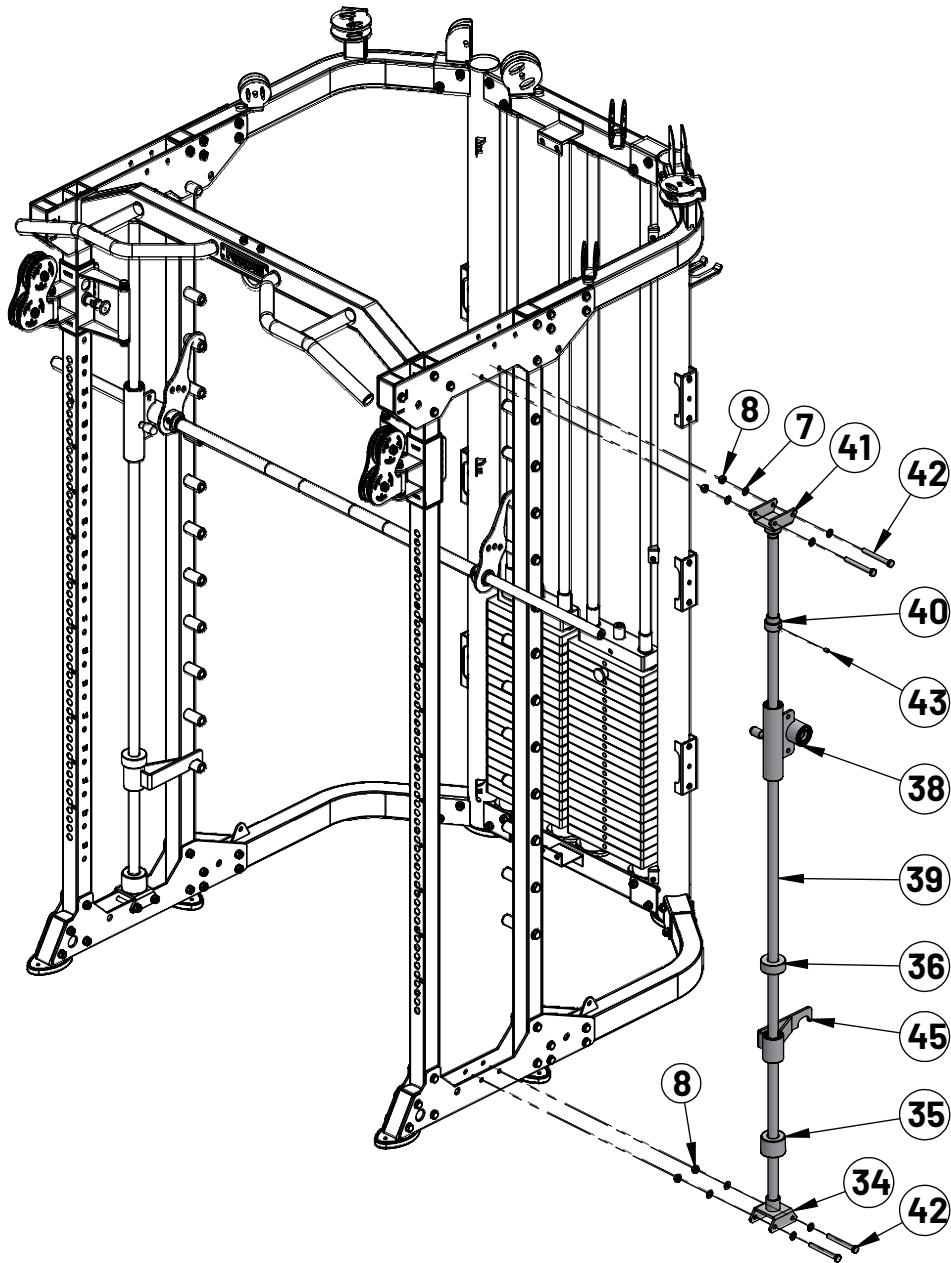

Key No.	Description	Note	Quantity
7	Flat Washer	$\phi 10$	8
8	Lock Nut	M10	4
34	Smith Bar Lower Connecting Sleeve		1
35	Large Rubber Bumper - Smith Bar	$\phi 60 \times \phi 26 \times 45$	1
36	Small Rubber Bumper - Smith Bar	$\phi 60 \times \phi 26 \times 25$	1
38	Smith Bar Sliding Sleeve		1
39	Guide Rod - Smith Bar	$\phi 25 \times 1878$	1
40	Smith Bar Guide Rod Fixing Sleeve	$\phi 40 \times \phi 25.5 \times 35$	1
41	Smith Bar Upper Connecting Sleeve		1
42	Hexagon Bolt	M10 \times 90	4
43	Grub Screw	M8 \times 10	1
45	Safety Hook Left		1

STEP 13 - ASSEMBLY

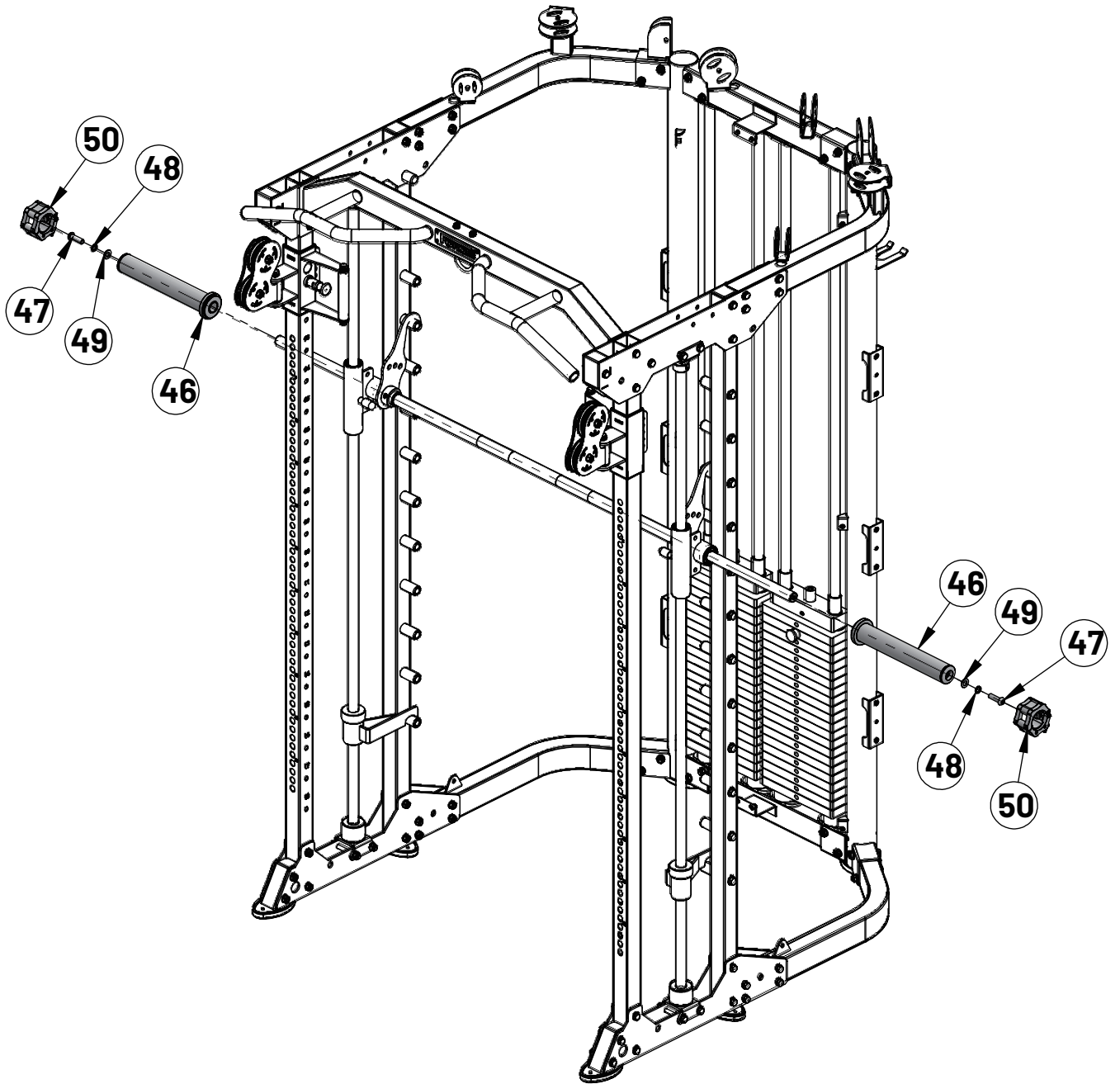

Key No.	Description	Note	Quantity
46	Smith Bar Weight Plate Sleeve		2
47	Hexagon Socket Button Head Screw	M12×40	2
48	Spring Gasket	φ12	2
49	Flat Washer	φ12	2
50	Olympic Quick Lock Collar	Φ85XΦ50XH49	2

STEP 14 - ASSEMBLY

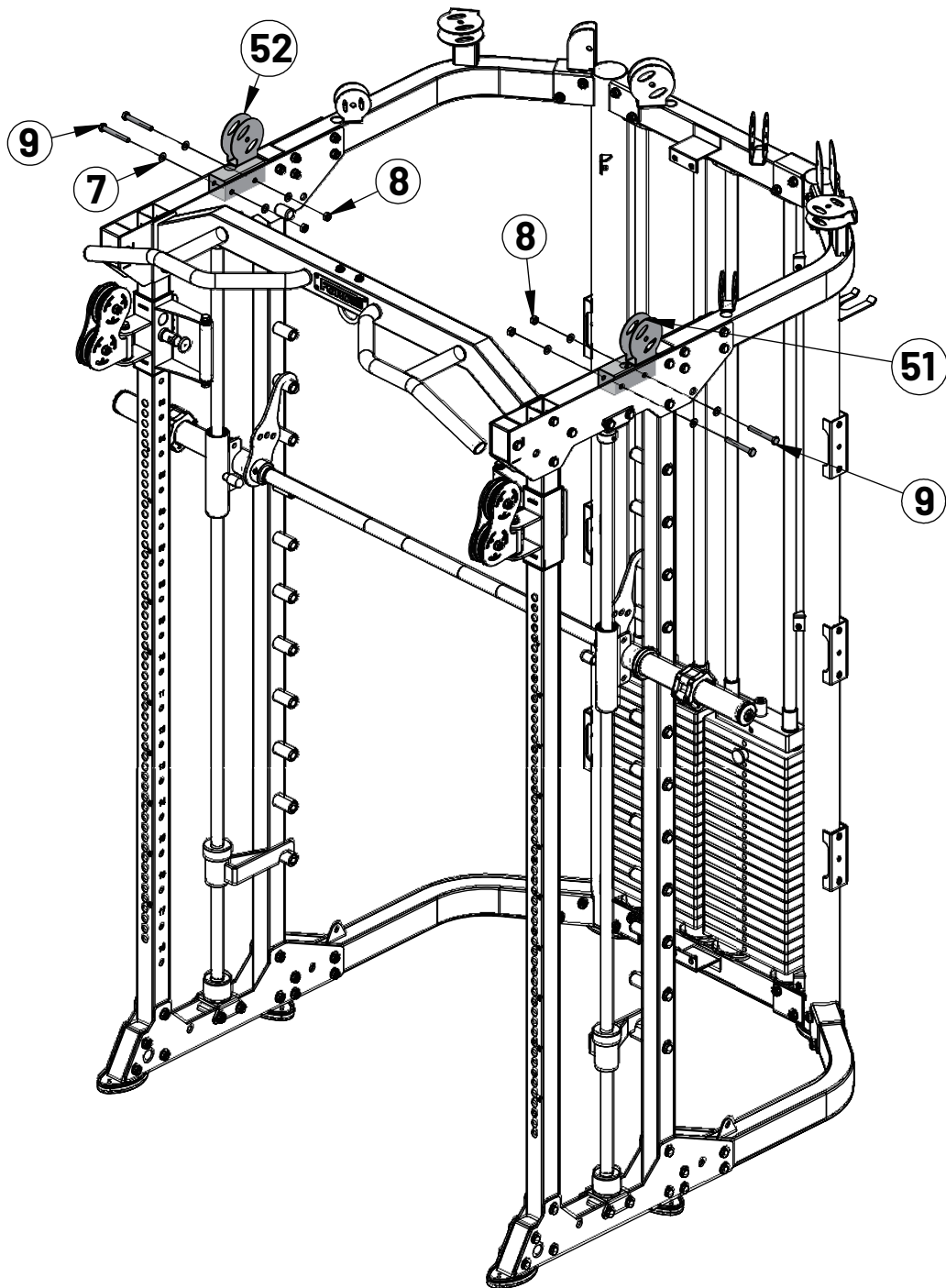

Key No.	Description	Note	Quantity
7	Flat Washer	φ10	8
8	Lock Nut	M10	4
9	Hexagon Bolt	M10×75	4
51	Top Pulley Insert Right		1
52	Top Pulley Insert Left		1

STEP 15 - ASSEMBLY

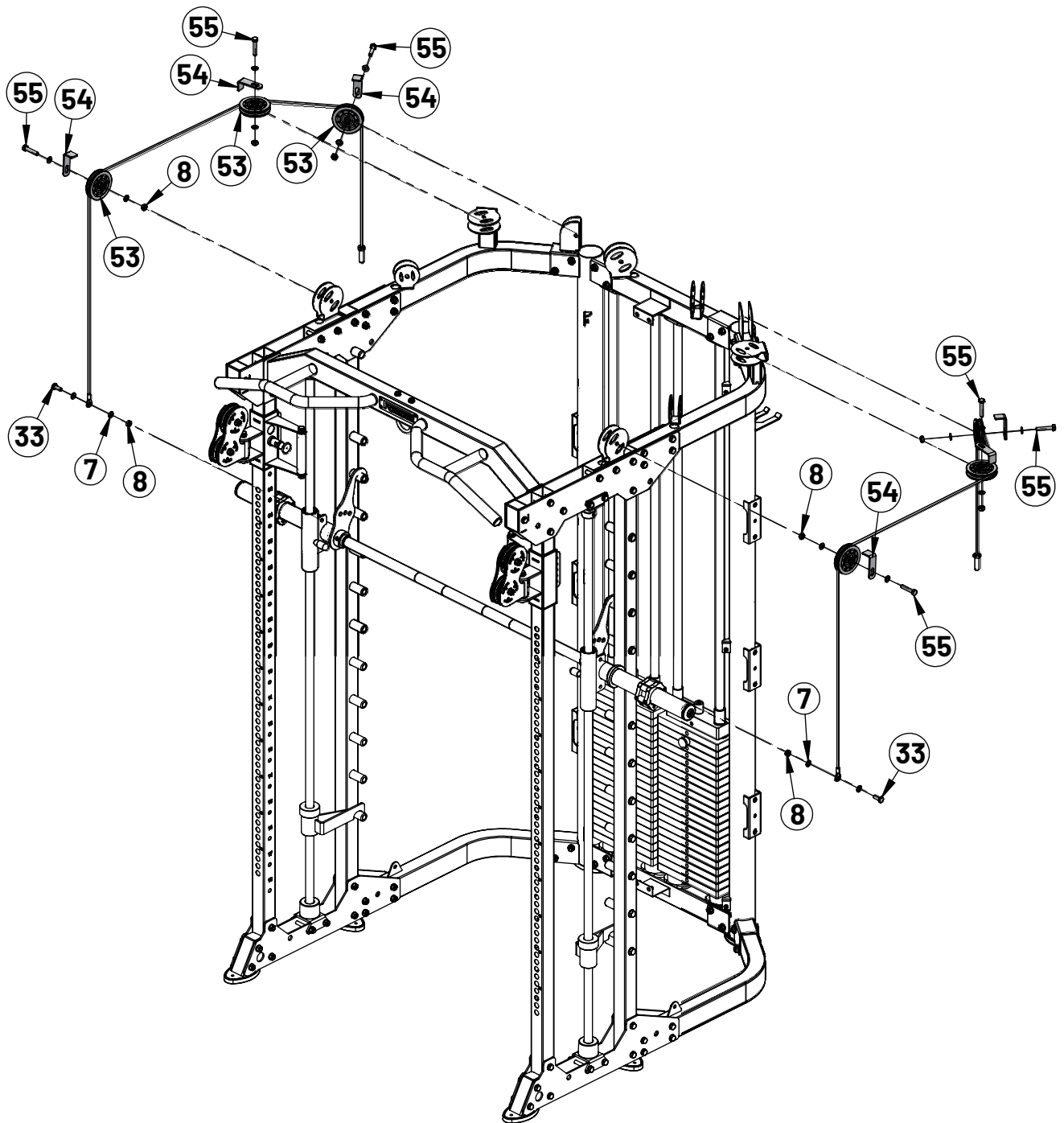

Key No.	Description	Note	Quantity
7	Flat Washer	$\phi 10$	16
8	Lock Nut	M10	8
33	Hexagon Bolt	M10×25	2
53	Pulley (96mm)	$\phi 92$	6
54	Cable Guide	T4	6
55	Hexagon Bolt	M10×50	6

STEP 16 - ASSEMBLY

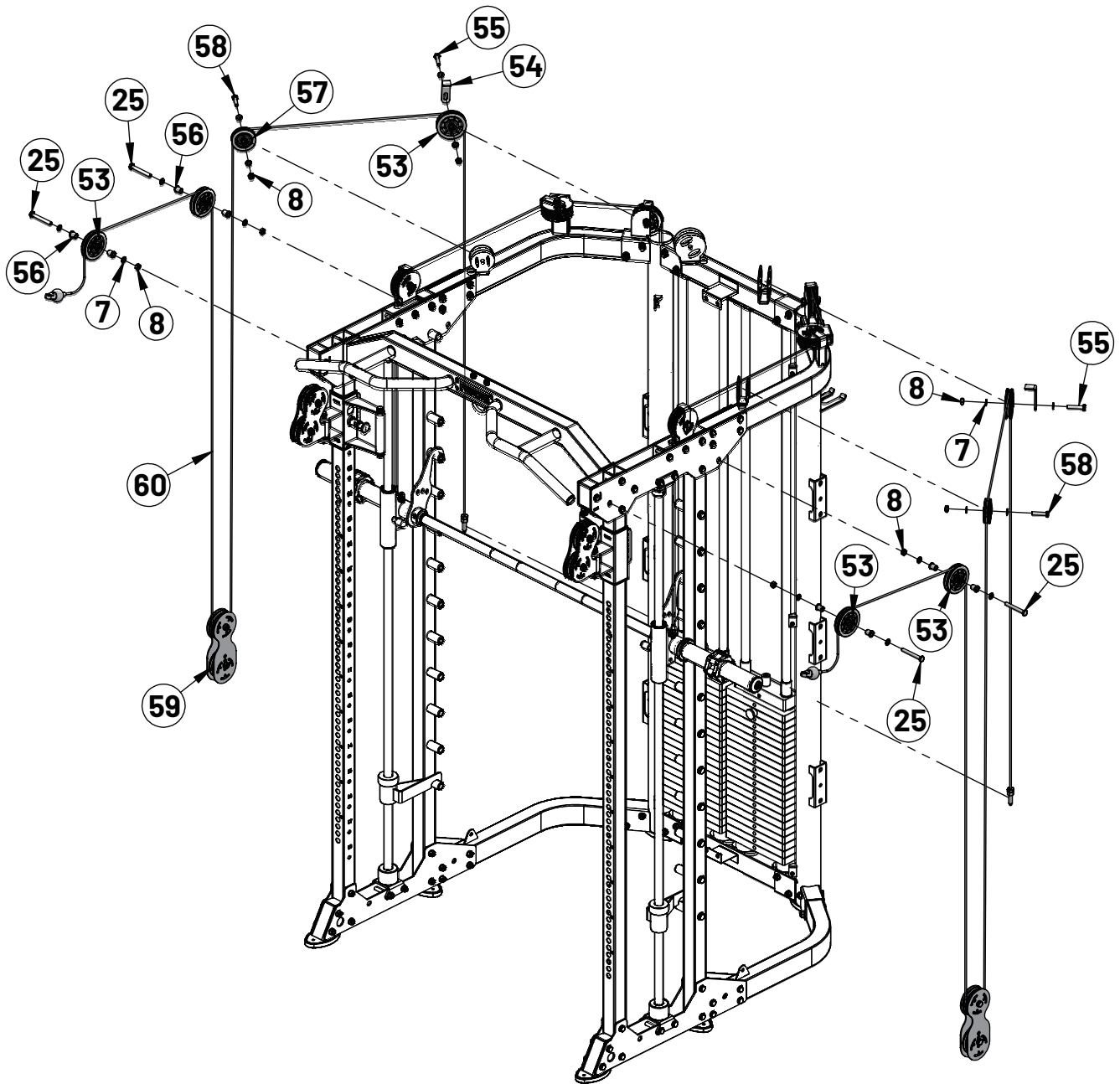

Key No.	Description	Note	Quantity
7	Flat Washer	φ10	16
8	Lock Nut	M10	8
25	Hexagon Bolt	M10×80	4
53	Pulley (96mm)	φ92	6
54	Cable Guide	T4	2
55	Hexagon Bolt	M10×50	2
56	Metal Bushing	Φ20*φ16*φ10.5*20.5	8
57	Pulley (75mm)	φ75	2
58	Hexagon Bolt	M10×45	2
59	Floating Pulley Frame		2
60	Weight Stack Cable	6400mm	2

STEP 17 - ASSEMBLY

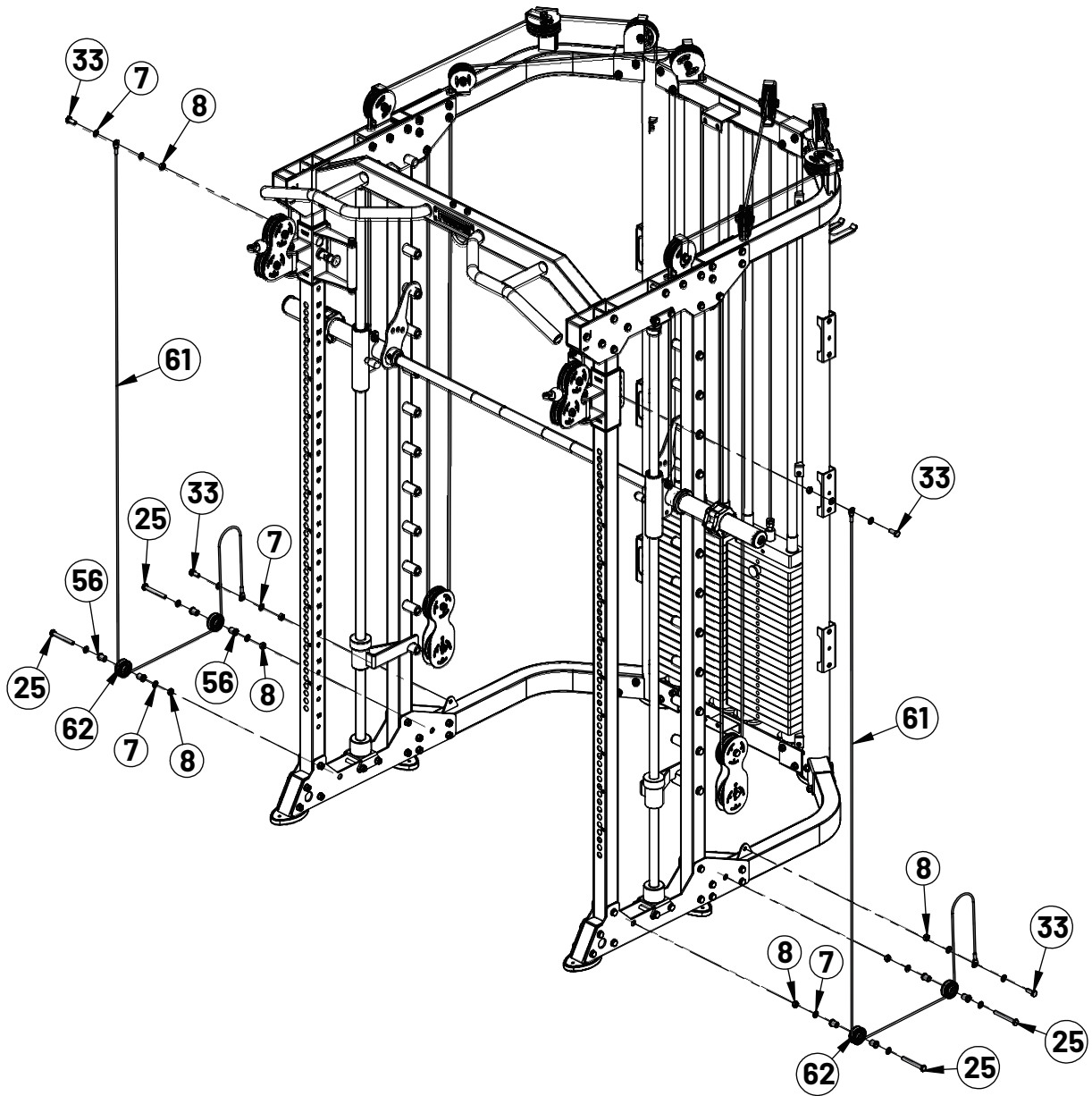

Key No.	Description	Note	Quantity
7	Flat Washer	$\phi 10$	16
8	Lock Nut	M10	8
25	Hexagon Bolt	M10×80	4
33	Hexagon Bolt	M10×25	4
56	Metal Bushing	$\Phi 20 * \phi 16 * \phi 10.5 * 20.5$	8
61	Lower Pull Cable	2785mm	2
62	Pulley (50mm)	$\phi 50$	4

STEP 18 - ASSEMBLY

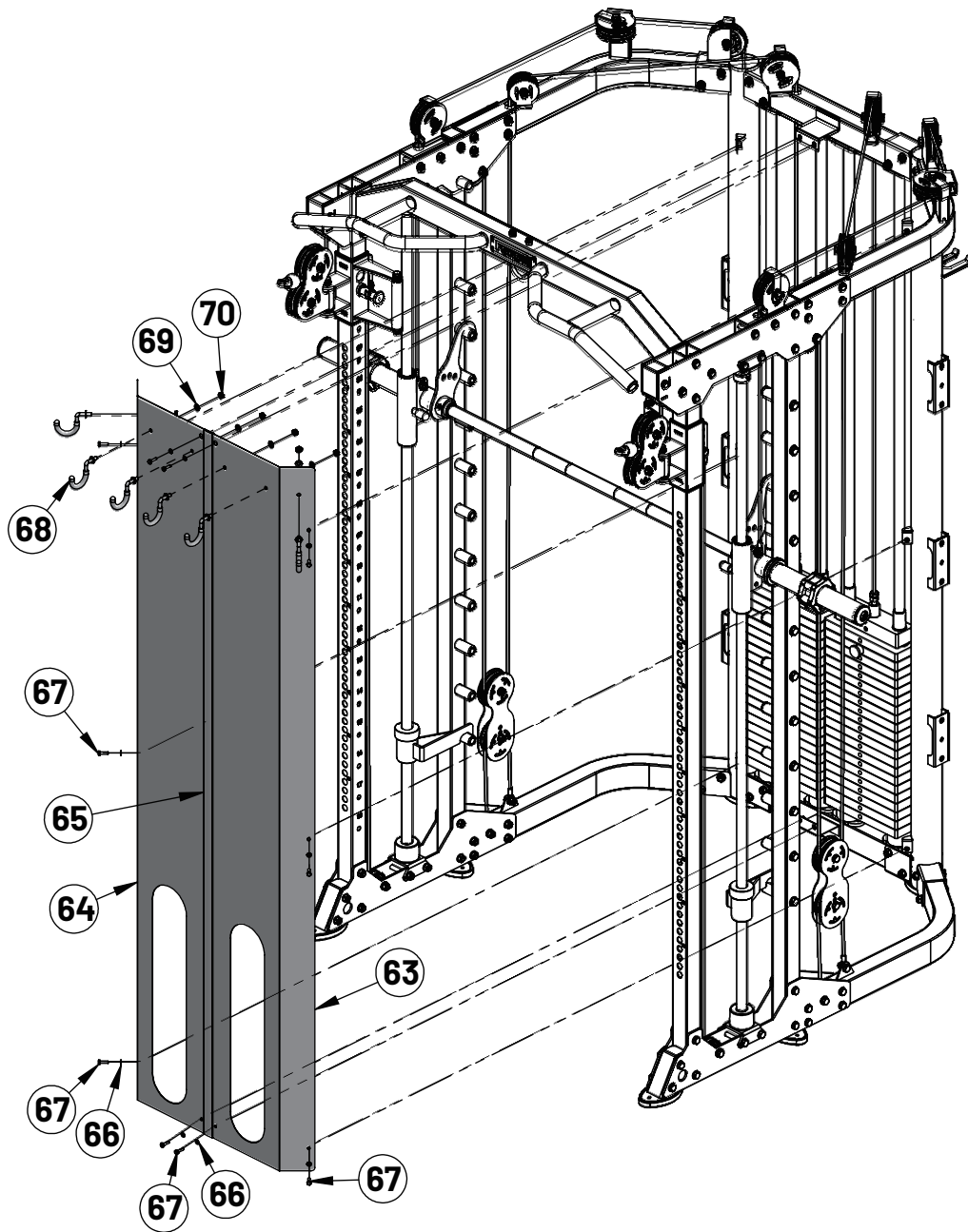

Key No.	Description	Note	Quantity
63	Weight Stack Shield - Right	T1	1
64	Weight Stack Shield - Left	T1	1
65	Shield Connection Piece	32*2027	1
66	Flat Washer	φ6	10
67	Hexagon Bolt	M6×20	10
68	Accessory Hook		6
69	Flat Washer	φ8	6
70	Lock Nut	M8	6

STEP 19 - ASSEMBLY

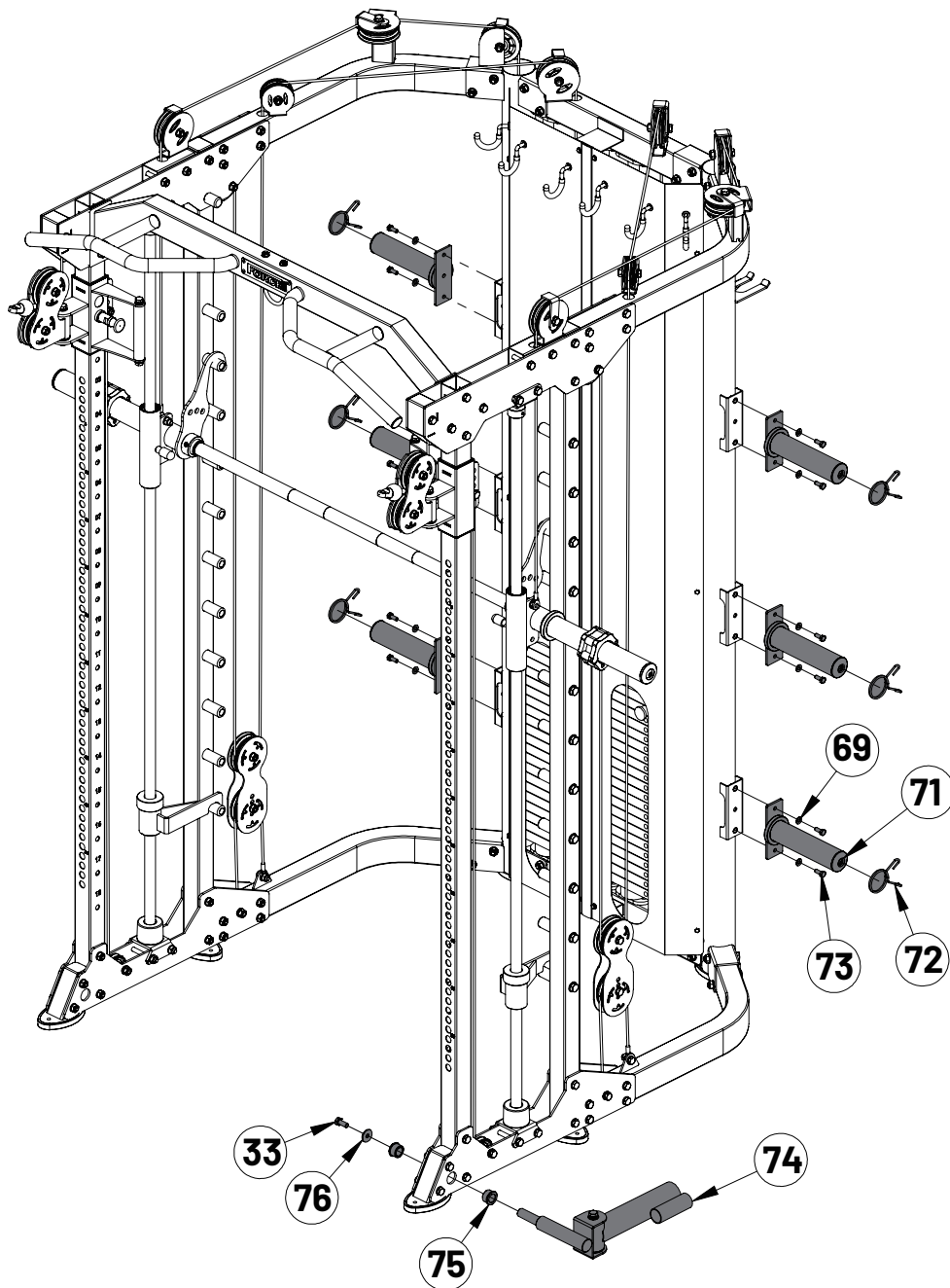

Key No.	Description	Note	Quantity
33	Hexagon Bolt	M10×25	1
69	Flat Washer	φ8	12
71	Olympic Weight Plate Holder		6
72	Olympic Spring Collar	φ50	6
73	Hexagon Bolt	M8×20	12
74	Core Trainer		1
75	Metal Bushing	φ33×φ29×φ20×18	2
76	Big Flat Washer	φ30*φ10*3	1

STEP 20 - ASSEMBLY

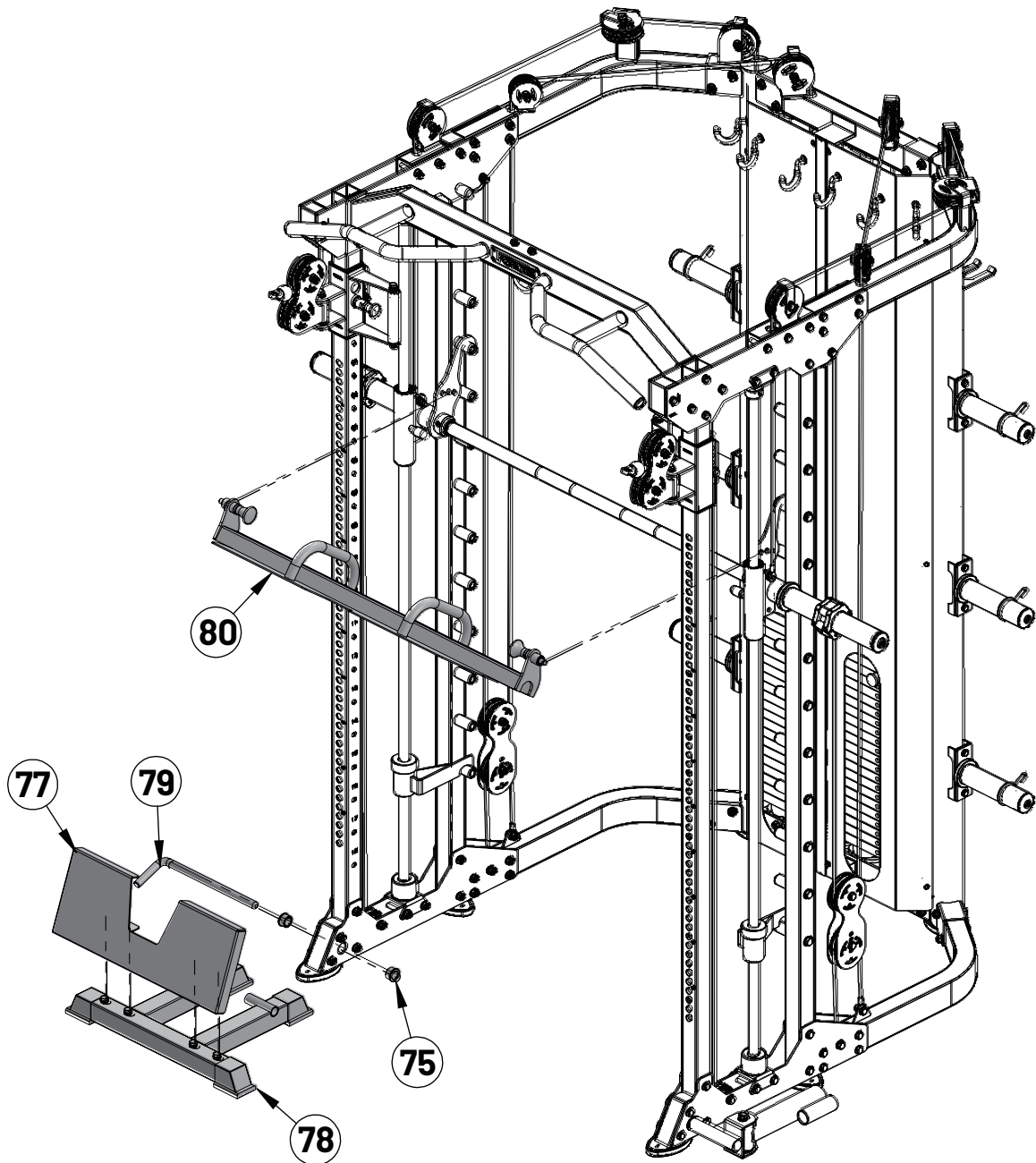

Key No.	Description	Note	Quantity
75	Metal Bushing	$\phi 33 \times \phi 29 \times \phi 20 \times 18$	2
77	Low Row Foot Plate		1
78	Low Row Foot Plate Support Frame		1
79	Band Peg	$\phi 18 \times 400$	1
80	Leg Press Foot Plate		1

STEP 21 - ASSEMBLY

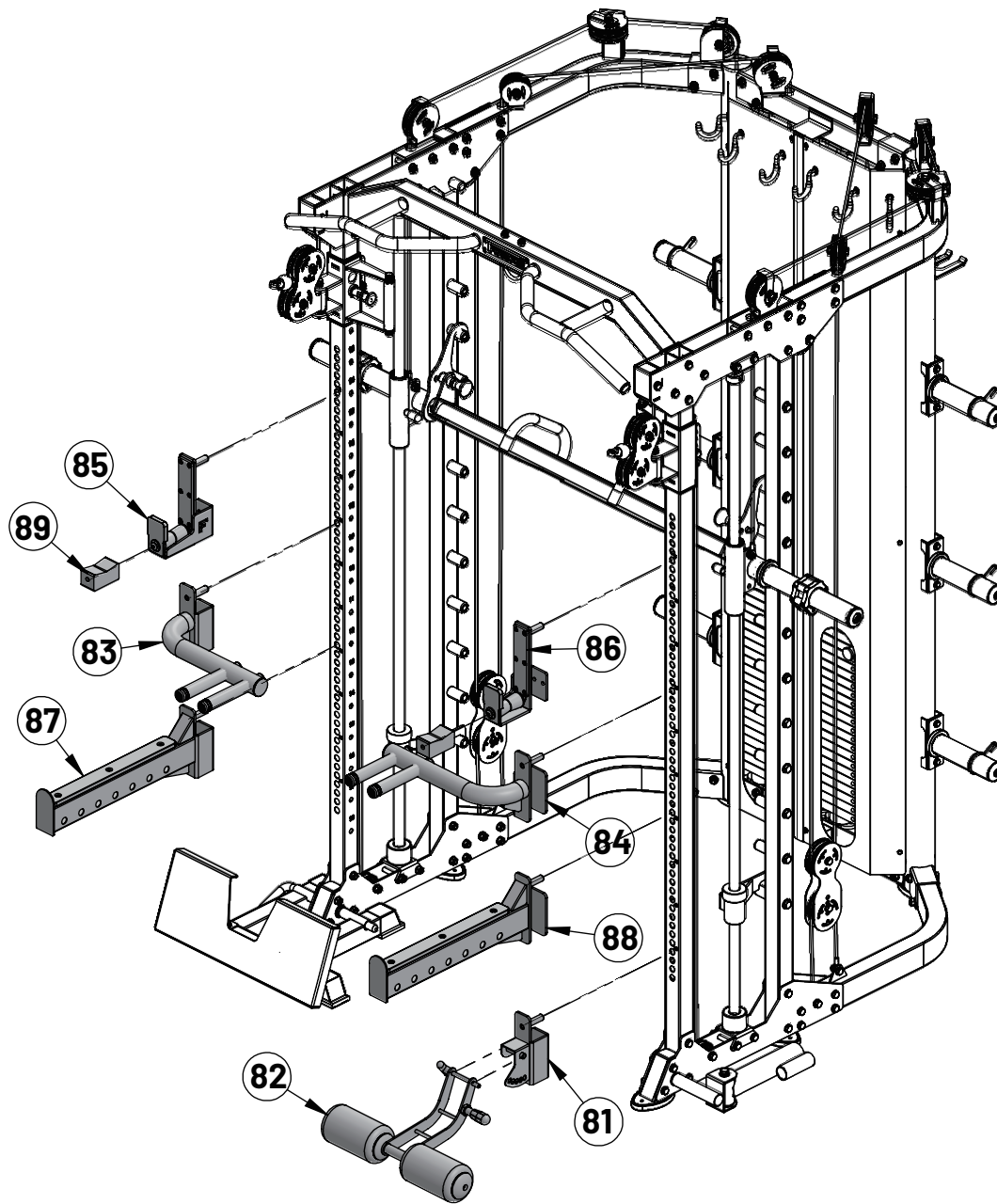

Key No.	Description	Note	Quantity
81	Knee Stabilizer J Hook		1
82	Knee Stabilizer		1
83	Dip Handle - Left		1
84	Dip Handle - Right		1
85	J-hook - Left		1
86	J-Hook - Right		1
87	Front Safety - Left		1
88	Front Safety - Right		1
89	J-hook Block Insert		2

ATTACHMENTS AND ACCESSORIES

Illustrations may appear different than actual attachments

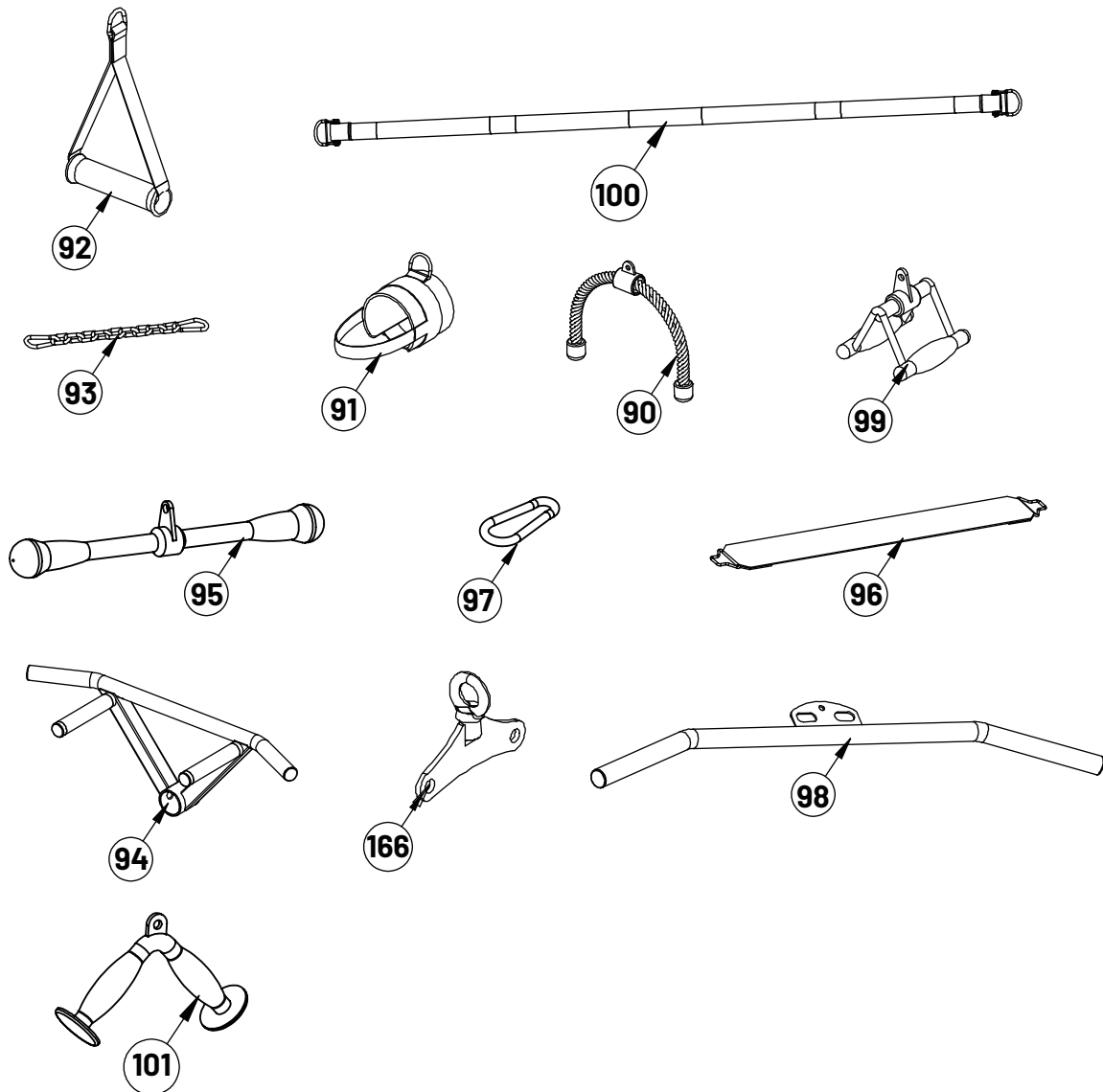

Key No.	Description	Note	Quantity
90	Tricep Rope	φ28*690	1
91	Ankle Strap	Leather with Ring	1
92	Single Stirrup - Nylon		2
93	Extension Chain		2
94	Core Trainer Handle		1
95	Short Revolving Straight Bar		1
96	Bodyweight Assist Strap	1020mm	1
97	Carabiner	Standard Part	2
98	Lat Pulldown Bar		1
99	Close Grip Triangle		1
100	Connection Bar - Straight		1
101	V-bar		1
166	Dual Cable Connector		1

EXPLODED DIAGRAMS

The upcoming pages feature an exploded view drawing of your product. These diagrams visually represents each component as it relates to the whole, although additional assembly by you is not required. It serves to help you identify and understand every part included in your purchase. While this guide offers a clear insight into how these parts fit together, it is particularly useful for troubleshooting and maintaining your product. Beyond practical benefits, the exploded view also aims to enhance your understanding of the product's design and functionality. As you explore these pages, you'll find they make it easier to discuss any component with our customer support, should the need arise. We hope this detailed visual approach not only informs but also enriches your experience with your new purchase.

LAT PULL DOWN BAR, 1 PC

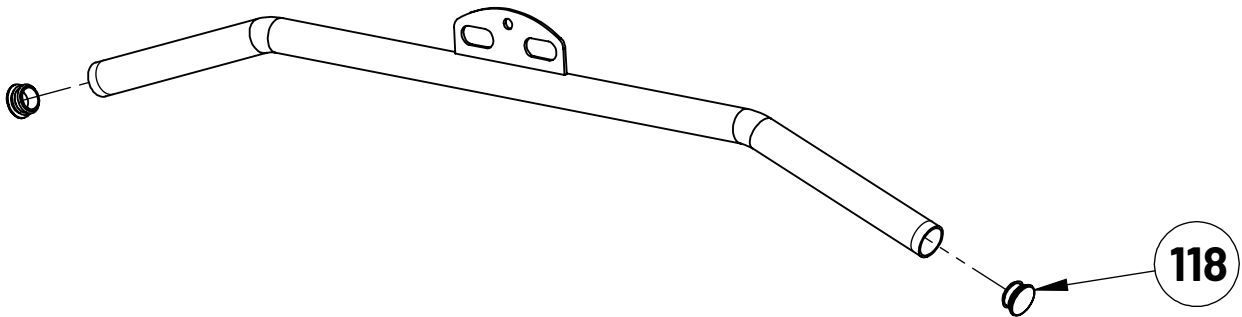

Key No.	Description	Note	Quantity
118	Round Tube Plug	$\phi 32 \times 1.5$	2

EXPLODED DIAGRAMS

UPRIGHT FRAME RIGHT, 1PC UPRIGHT FRAME LEFT, 1PC

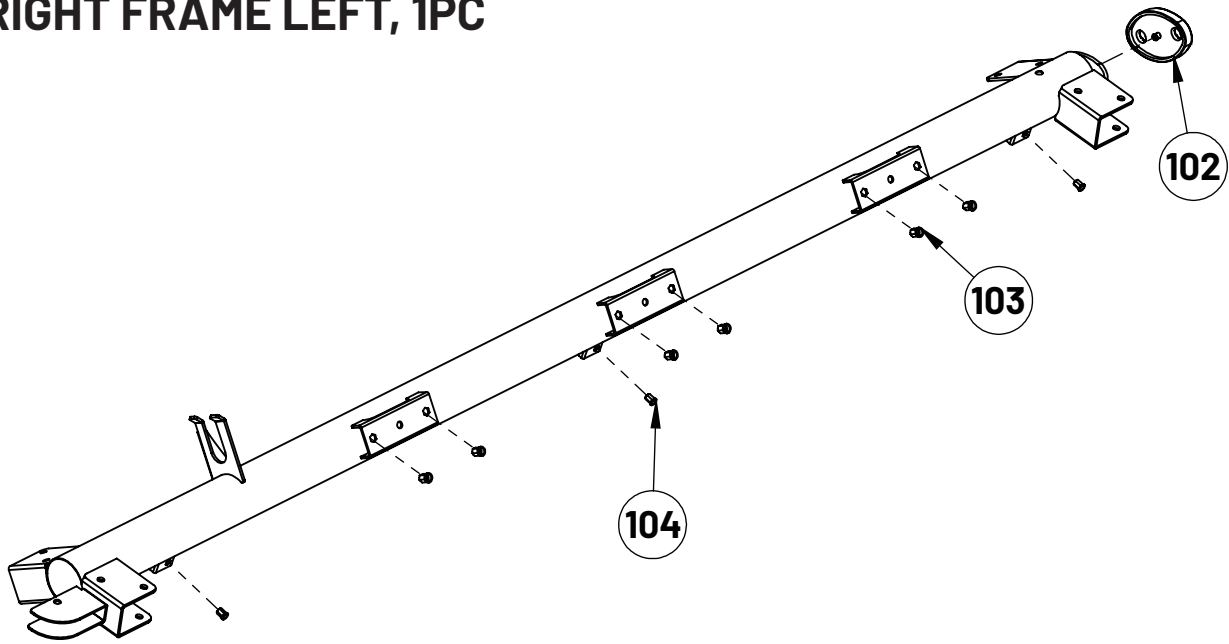

Key No.	Description	Note	Quantity
102	Oval Pad	131*80	1
103	Hexagon Rivet Nut	M8	6
104	Hexagon Rivet Nut	M6	3

MAINFRAME CONNECTING TUBE, 1PC

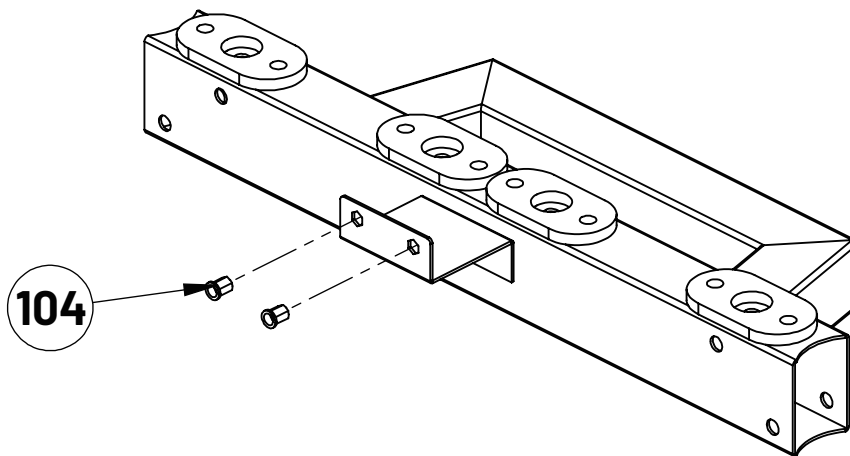

Key No.	Description	Note	Quantity
104	Hexagon Rivet Nut	M6	2

EXPLODED DIAGRAMS

UPPER MAINFRAME CONNECTING TUBE, 1PC

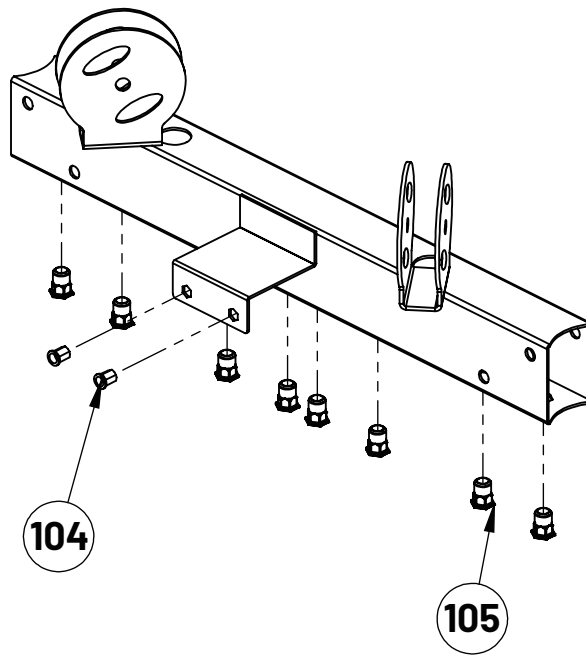

Key No.	Description	Note	Quantity
104	Hexagon Rivet Nut	M6	2
105	Countersunk Hexagon Rivet Nut	M10	8

FOOT TUBE COVER, 2 PCS

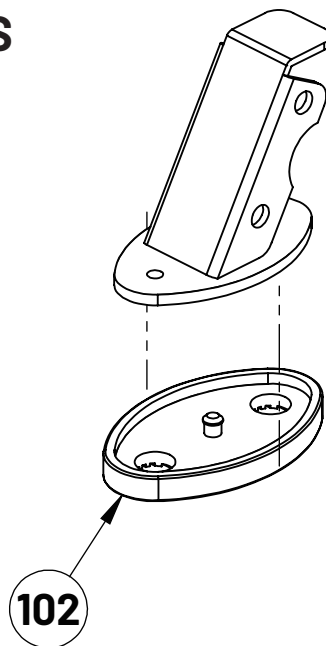

Key No.	Description	Note	Quantity
102	Oval Pad	131*80	1

EXPLODED DIAGRAMS

UPRIGHT TUBE, 2 PCS

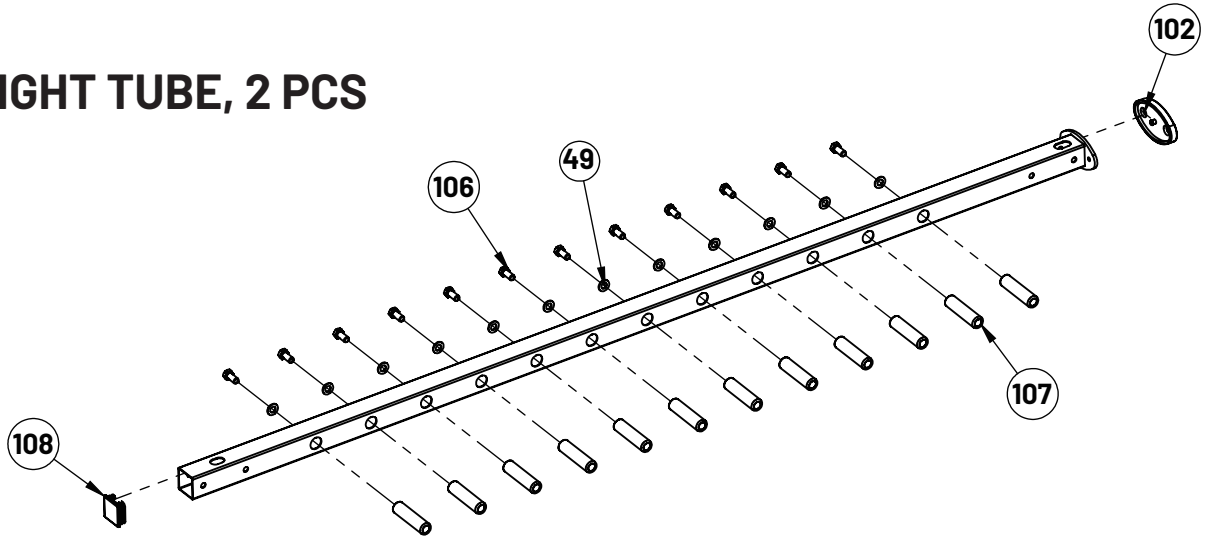

Key No.	Description	Note	Quantity
49	Flat Washer	φ12	12
102	Oval Pad	131*80	1
106	Hexagon Bolt	M12×25	12
107	Upright Tube	φ25*M12*98	12
108	Inner Plug	□50×50×1.2	1

CHIN UP BAR, 1 PC

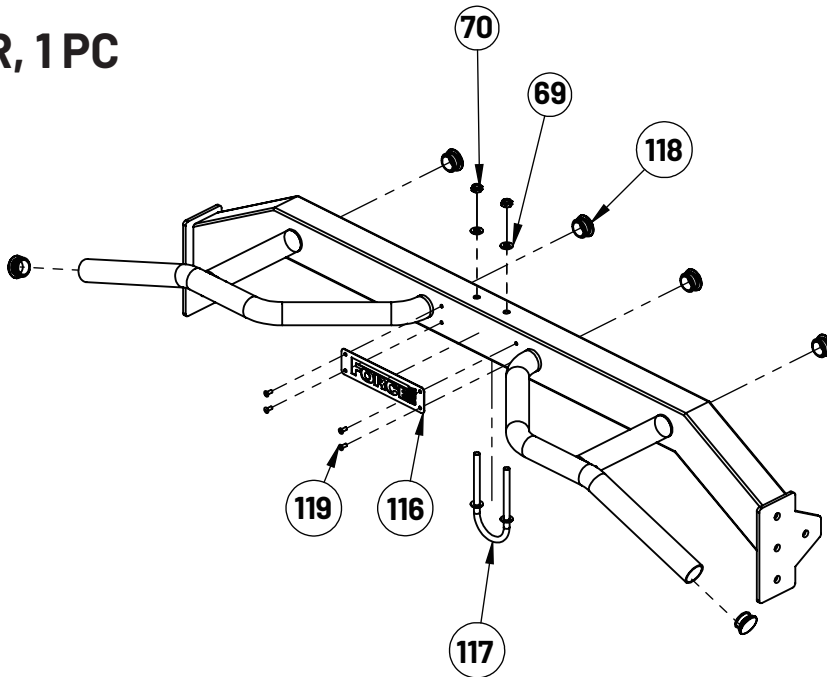

Key No.	Description	Note	Quantity
69	Flat Washer	φ8	2
70	Lock Nut	M8	2
116	Logo Plate	T1	1
117	Hanging Ring		1
118	Round Tube Plug	φ32×1.5	6
119	Oblate Core-pulling Rivet	4×10	4

EXPLODED DIAGRAMS

SLIDING TUBE LEFT, 1PC SLIDING TUBE RIGHT, 1PC

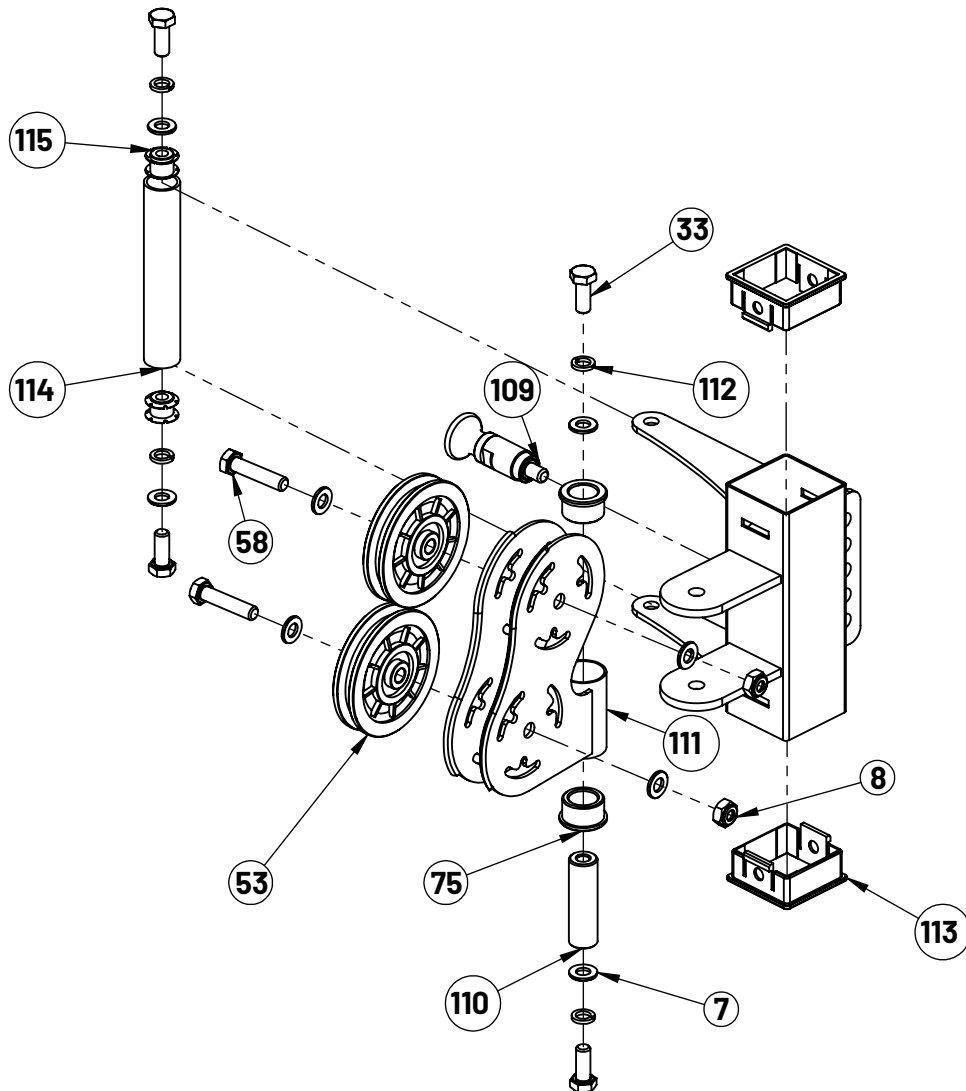

Key No.	Description	Note	Quantity
7	Flat Washer	$\phi 10$	8
8	Lock Nut	M10	2
33	Hexagon Bolt	M10×25	4
53	Pulley (96mm)	$\phi 92$	2
58	Hexagon Bolt	M10×45	2
75	Metal Bushing	$\phi 33 \times \phi 29 \times \phi 20 \times 18$	2
109	Spring Pin	M20×1.5- $\phi 10$	1
110	Internal Thread Shaft	$\phi 20 \times 67$	1
111	Pulley Rotating Sleeve		1
112	Spring Gasket	$\phi 10$	4
113	Bushing	50-60	2
114	Handgrip Tube	$\phi 25 \times 2$	1
115	Two Layer Spring Slice Nut	$\phi 23$ -M10	2

EXPLODED DIAGRAMS

SAFETY HOOK RIGHT, 1PC
SAFETY HOOK LEFT, 1PC

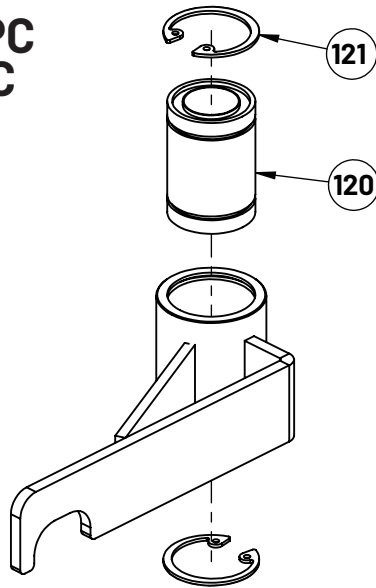

Key No.	Description	Note	Quantity
120	Linear Bearing	$\phi 40 * \phi 25 * 58$	1
121	Spring Stop Collar	$\phi 40$	2

SLIDING SLEEVE, 2PCS

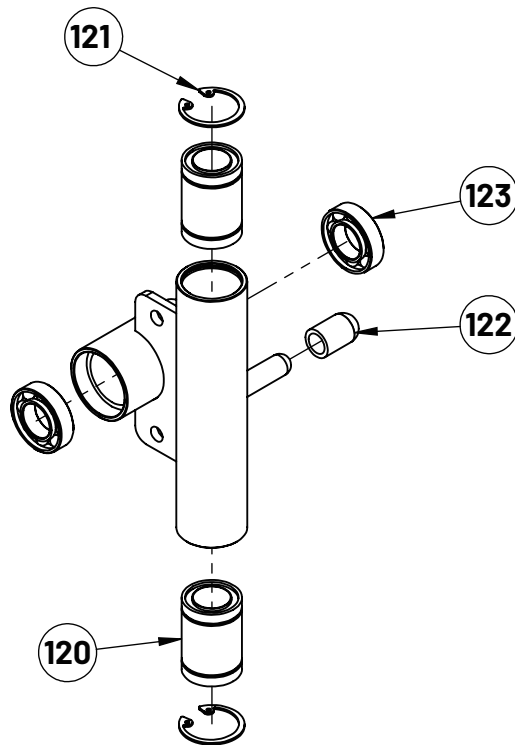

Key No.	Description	Note	Quantity
120	Linear Bearing	$\phi 40 * \phi 25 * 58$	2
121	Spring Stop Collar	$\phi 40$	2
122	Buffer Sleeve	$\phi 21 * 35$	1
123	Deep Groove Ball Bearing	6005	2

EXPLODED DIAGRAMS

PIPE, 1 PC

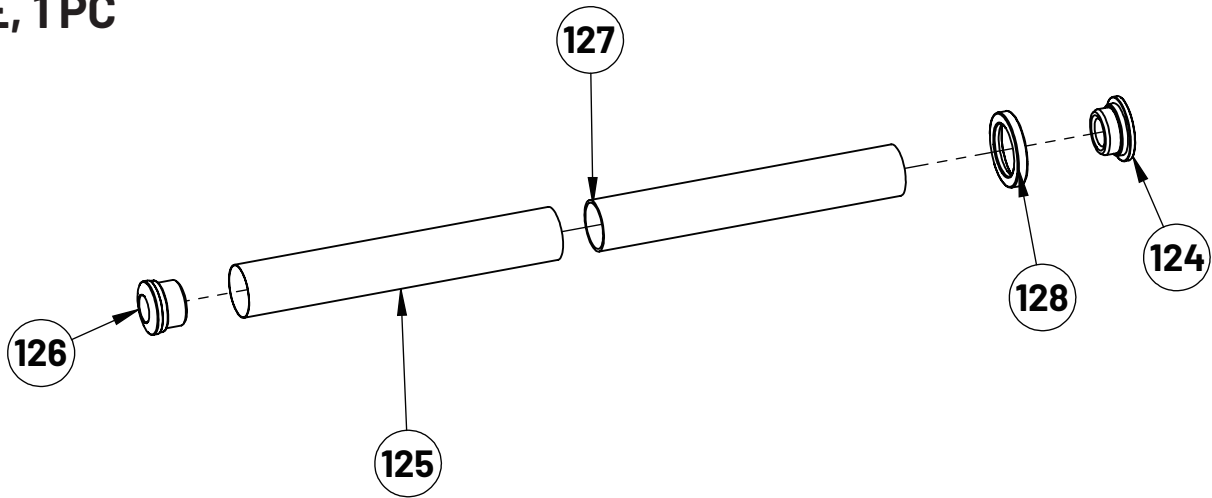

Key No.	Description	Note	Quantity
124	Inner Stop Collar	$\phi 60 \times 27$	1
125	Outer Sleeve Tube	$\phi 49.5 \times 0.6$	1
126	Barbell Bar Stopper-Arc	$\phi 50 \times 37$	1
127	Barbell Bar Inner Sleeve Tube	$\phi 48 \times 2.5$	1
128	Rubber Stop Collar	$\phi 70 \times \phi 50 \times \phi 10$	1

FLOATING PULLEY BRACKET, 2 PCS

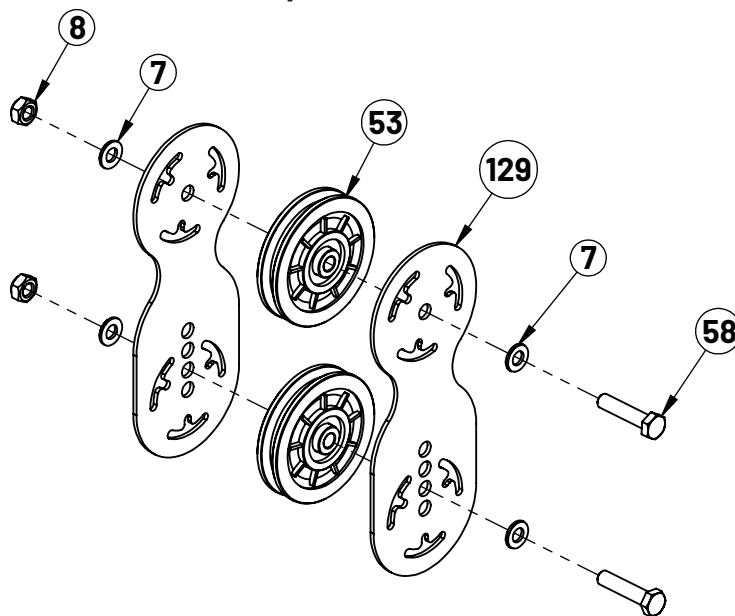

Key No.	Description	Note	Quantity
7	Flat Washer	$\phi 10$	4
8	Lock Nut	M10	2
53	Pulley (96mm)	$\phi 92$	2
58	Hexagon Bolt	M10 \times 45	2
129	Pulley Adjusting Plate	T3	2

EXPLODED DIAGRAMS

HOOK, 6 PCS

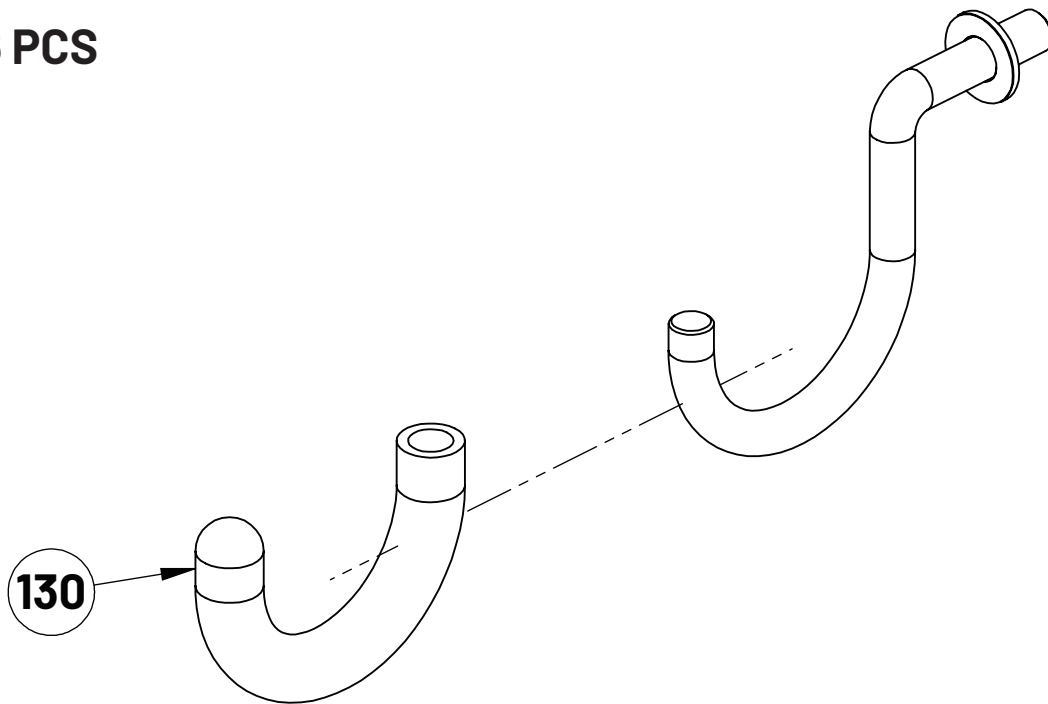

Key No.	Description	Note	Quantity
130	Hook Plastic Dip Sleeve	Φ8*100	1

BARBELL PLATE STORAGE HORNS, 6 PCS

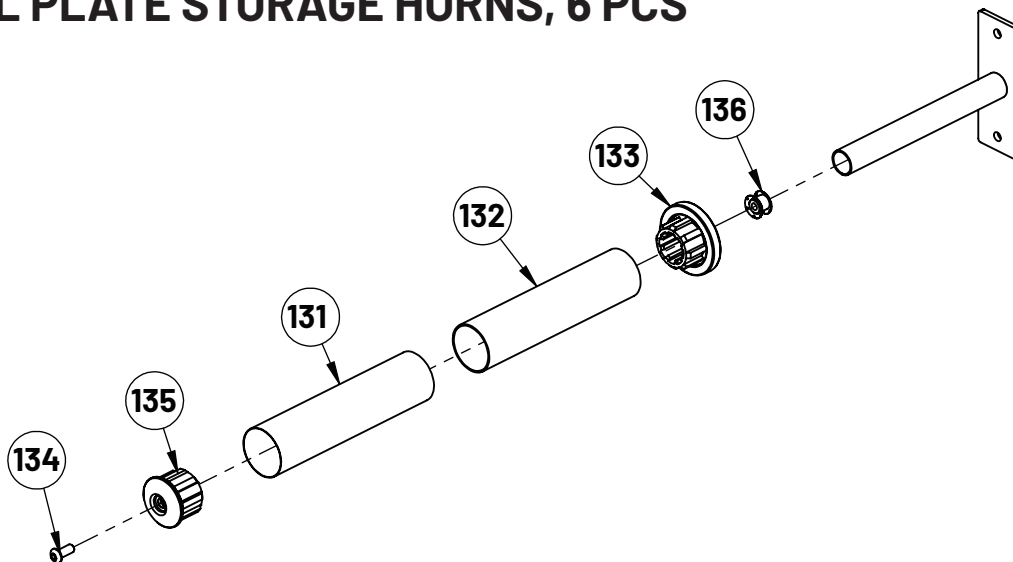

Key No.	Description	Note	Quantity
131	Outer Sleeve Tube	φ49.5*0.6*200	1
132	Barbell Bar Sleeve Tube	φ48*1.5*198	1
133	Barbell Inner Support Sleeve	φ70×φ44.8×φ25.5×30	1
134	Hexagon Socket Button Head Screw	M8*20	1
135	Outer Support Sleeve	φ50×φ44.8×φ25.5	1
136	Two Layer Spring Slice Nut	φ23-M8	1

EXPLODED DIAGRAMS

CORE TRAINER, 1 PC

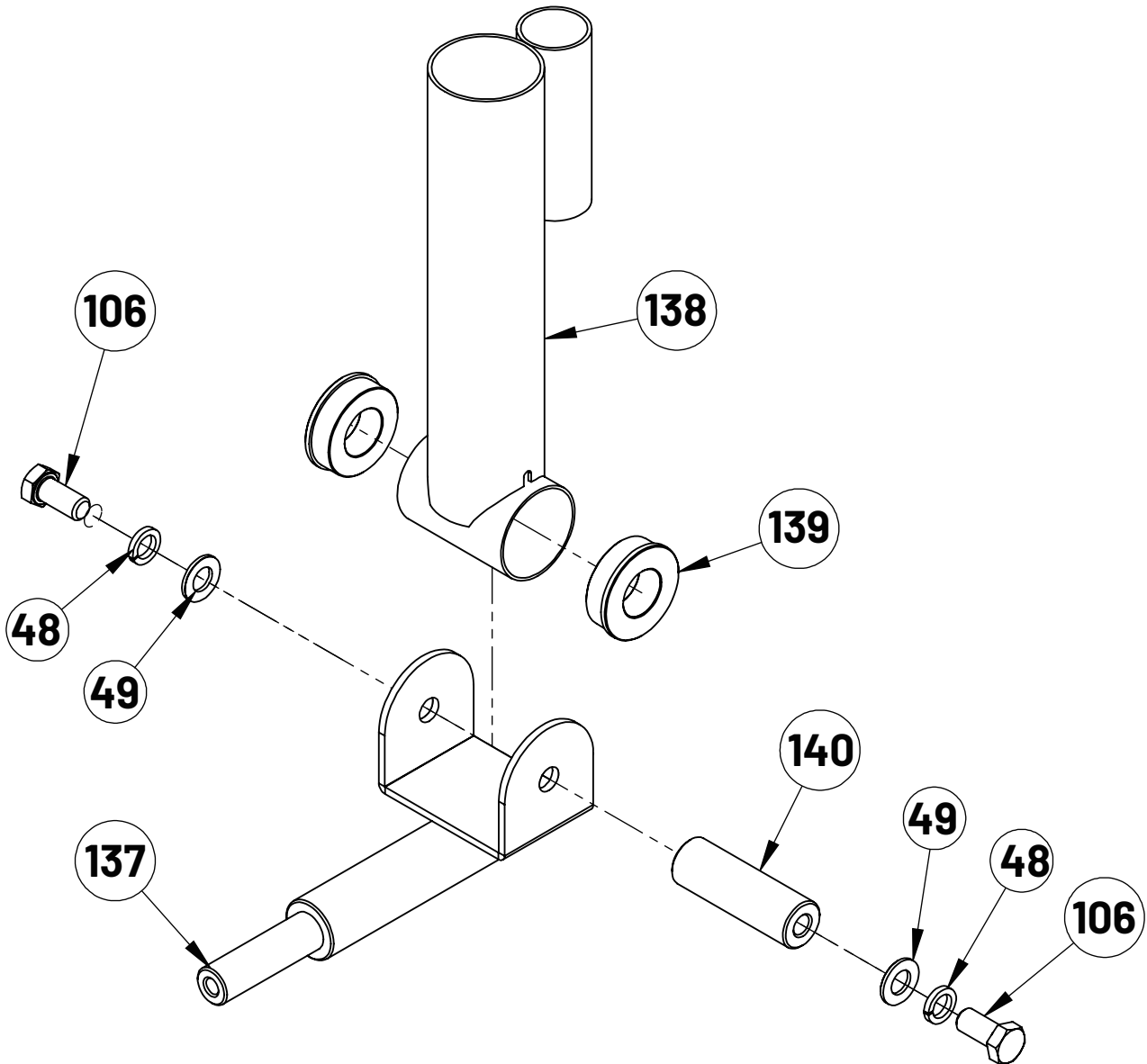

Key No.	Description	Note	Quantity
48	Spring Gasket	$\phi 12$	2
49	Flat Washer	$\phi 12$	2
106	Hexagon Bolt	M12×25	2
137	Core Trainer Weldment		1
138	Double Barbell Rotater		1
139	Powder Sleeve	$\phi 50 \times \phi 47 \times \phi 25 \times 15$	2
140	Internal Thread Shaft	$\phi 25 \times 77 \times M12$	1

EXPLODED DIAGRAMS

FOOT PLATE BRACKET, 1 PC

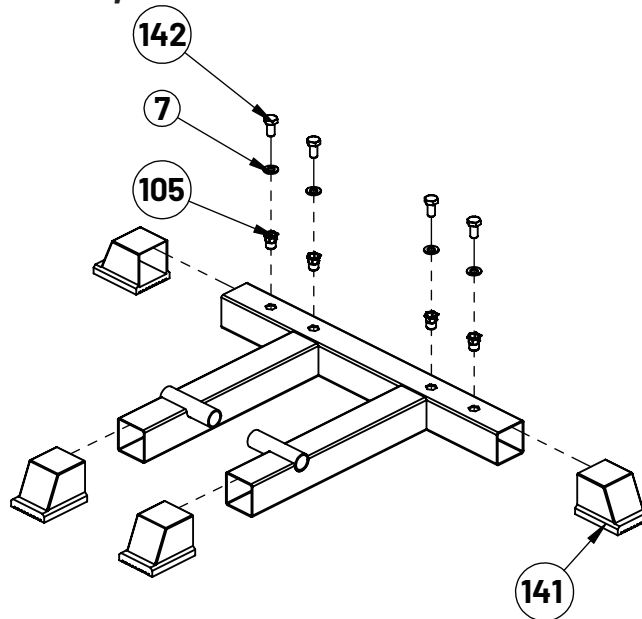

Key No.	Description	Note	Quantity
7	Flat Washer	φ10	4
105	Countersunk Hexagon Rivet Nut	M10	4
141	Foot Cover	□50×50	4
142	Hexagon Bolt	M10×20	4

LEG PRESS PLATE, 1 PC

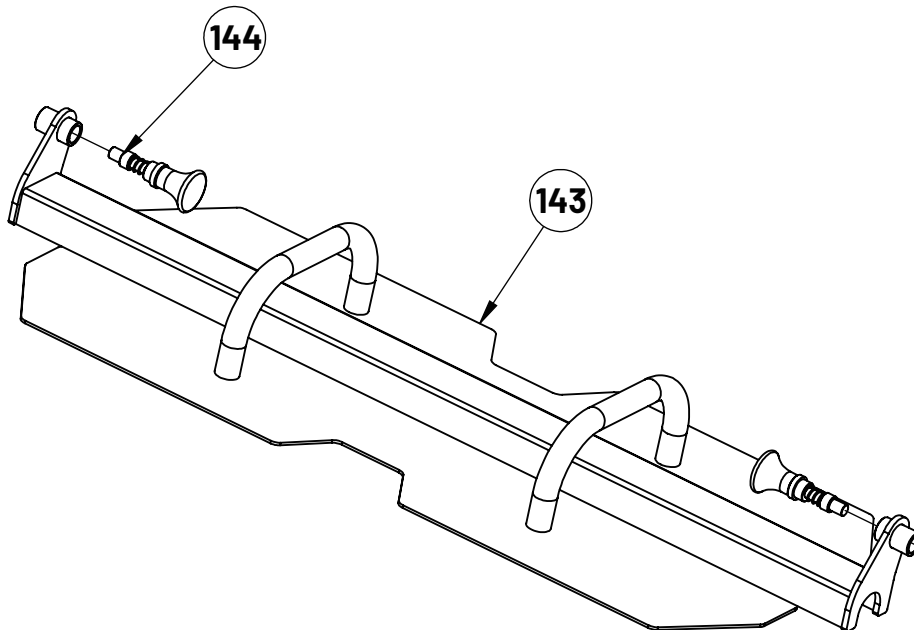

Key No.	Description	Note	Quantity
143	Foot Plate		1
144	Umbrella Pin	φ12×M20×40	2

EXPLODED DIAGRAMS

LEG CURL TUBE, 1 PC

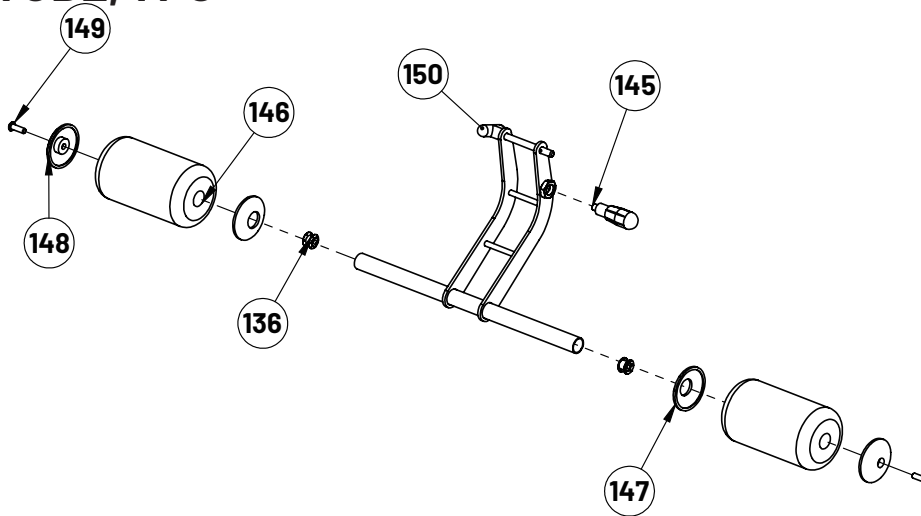

Key No.	Description	Note	Quantity
136	Two Layer Spring Slice Nut	$\phi 23$ -M8	2
145	Lock Pin	M18X12X $\phi 10$	1
146	Foam Roller	$\phi 25$ X $\phi 100$ X175	2
147	Foam Inner Cover	$\phi 70$ X $\phi 27$ X12	2
148	Foam Outer Cover	$\phi 70$ X $\phi 9$ X14	2
149	Hexagon Socket Button Head Screw	M8X25	2
150	T-shaped Pin	$\phi 10$ X100	1

DIP HANDLE RIGHT, 1PC DIP HANDLE LEFT, 1PC

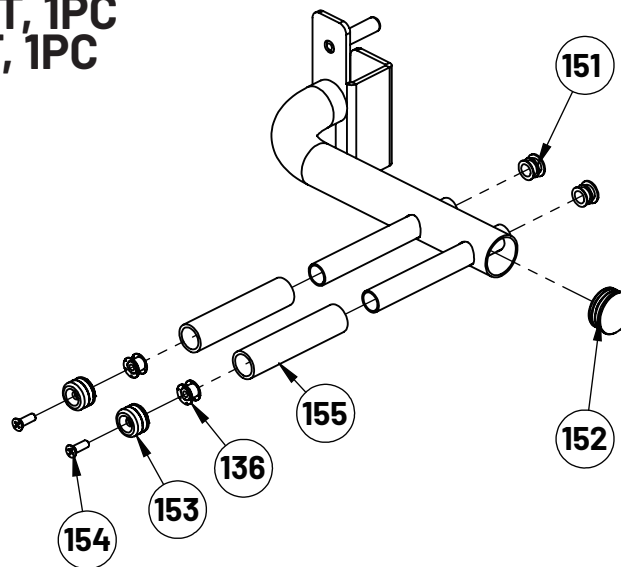

Key No.	Description	Note	Quantity
136	Two Layer Spring Slice Nut	$\phi 23$ -M8	2
151	Round Tube Plug	$\Phi 25$ X2	2
152	End Cap	$\phi 48$ X2.5	1
153	Dip Handle Lock Ring	$\phi 31.5$ X $\phi 25.5$	2
154	Cross Recessed Countersunk Head Screw	M8X20	2
155	Handle Cover	$\phi 25$ X140	2

EXPLODED DIAGRAMS

J HOOK LEFT, 1PC
J HOOK RIGHT, 1PC

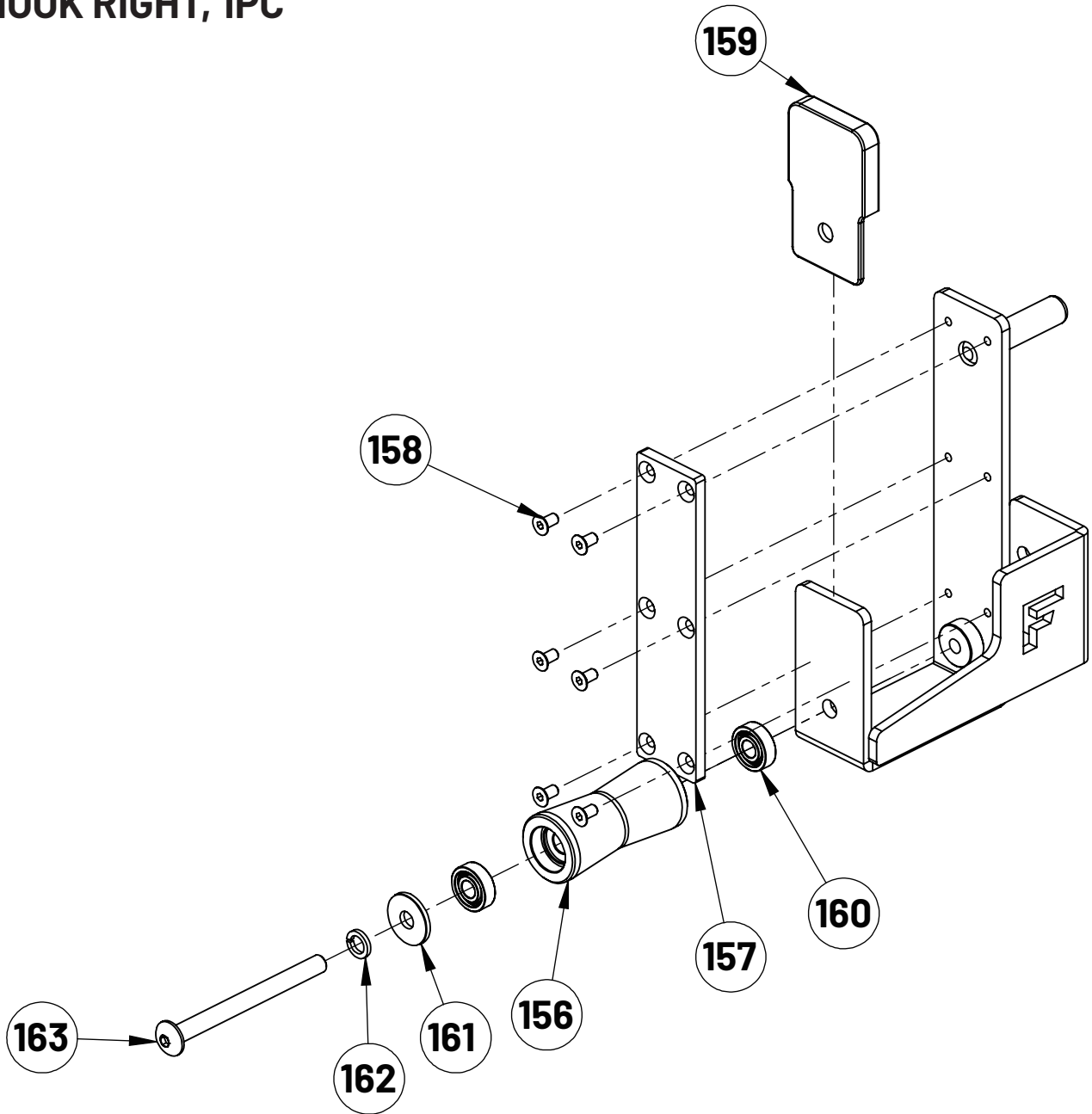

Key No.	Description	Note	Quantity
156	J Hook Roller	φ40*88	1
157	Rubber Sheet	φ190×45×7	1
158	Countersunk Head Hexagon Screw	M6×12	6
159	J Hook Front Rubber Sheet	12.3*96	1
160	Deep Groove Ball Bearing	6000	2
161	Big Flat Washer	φ30*φ10*3	1
162	Spring Washer	φ10	1
163	Hexagon Socket Button Head Screw	M10×115	1

EXPLODED DIAGRAMS

SAFETY SPOTTER RIGHT, 1 PC
SAFETY SPOTTER LEFT, 1 PC

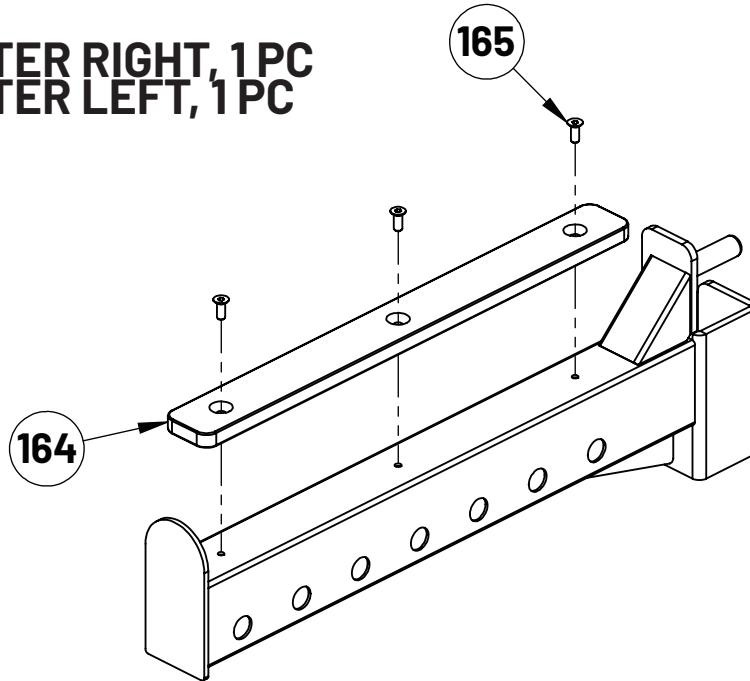

Key No.	Description	Note	Quantity
164	Front Safety Tube Rubber Sheet	T12	1
165	Countersunk Hexagon Socket Button Screw	M6×16	3

PULL LIFT DEVICE, 1 PC

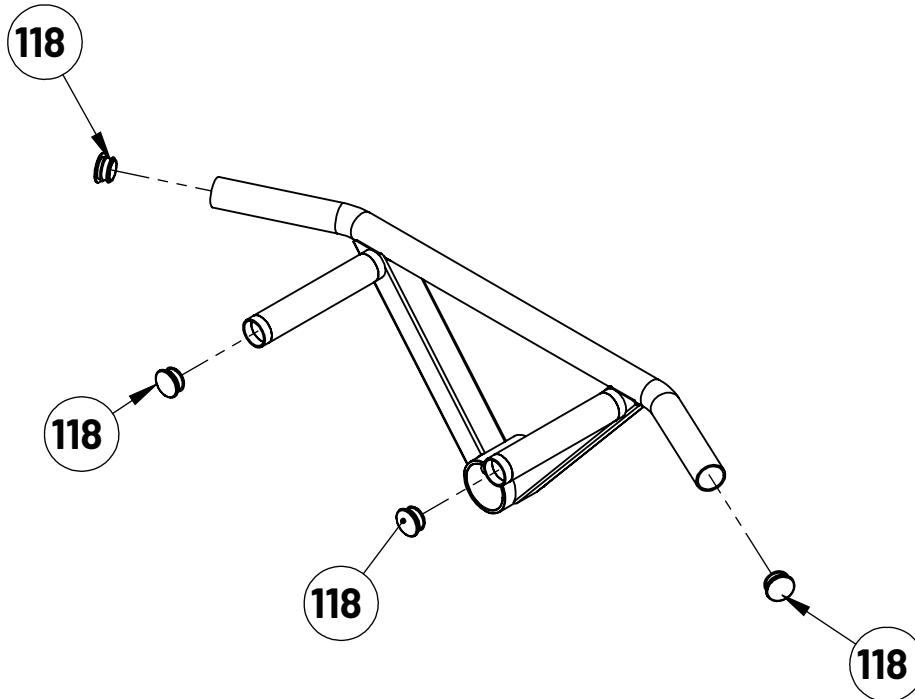

Key No.	Description	Note	Quantity
118	Round Tube Plug	φ32×1.5	4

WARRANTY INFO

For warranty information please contact the dealer nearest to you.



<https://www.forceusa.com/locator>

FORCE **USA**

forceusa.com