

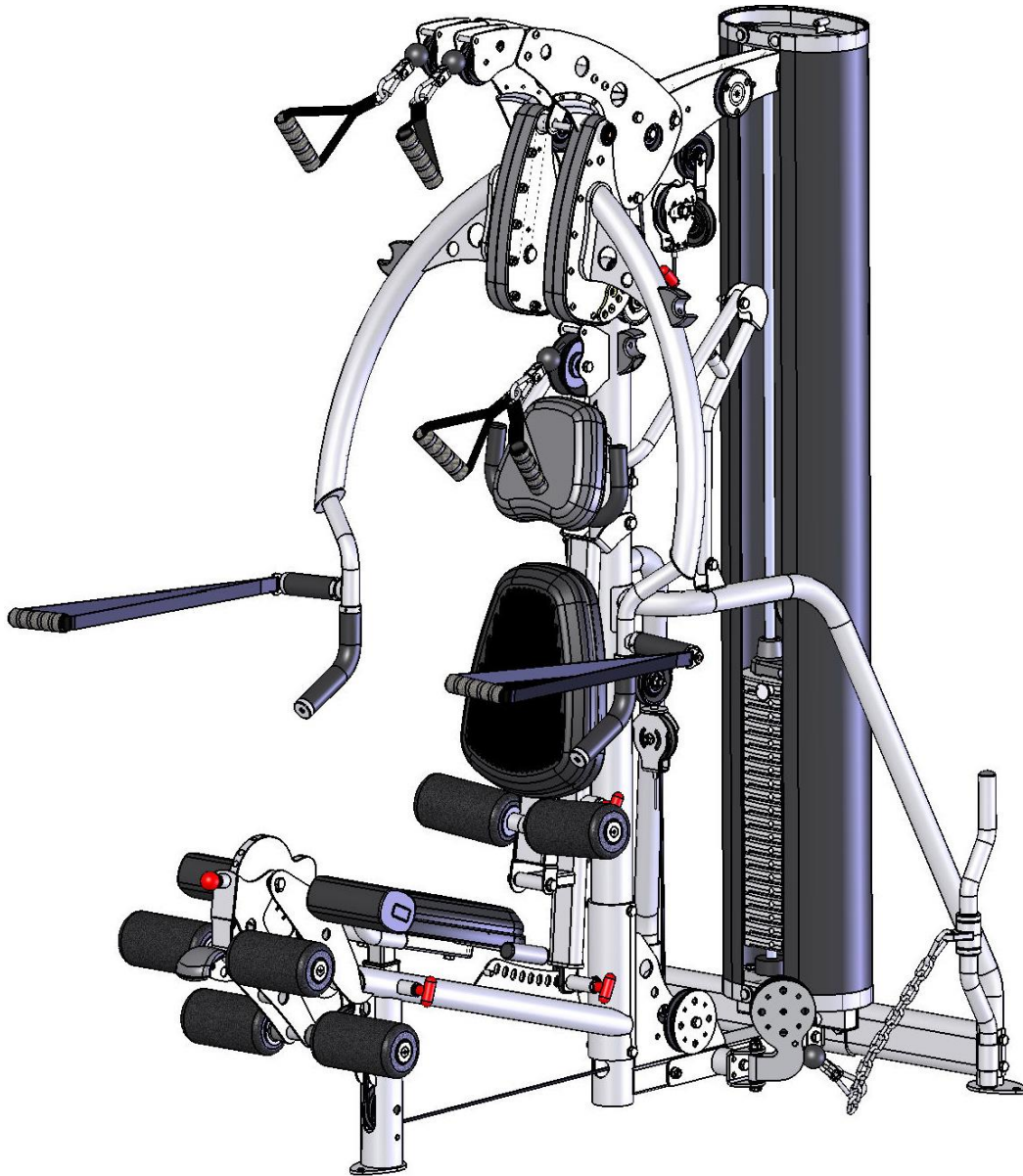

## ASSEMBLY & OPERATION MANUAL



RECORD SERIAL NUMBER HERE

**CONGRATULATIONS...** You've just taken the first step to a healthier and stronger body. This home gym by Inspire Fitness offers the key to unlocking your body's potential. Regular strength training on a home gym has been shown to deliver a host of benefits including: increased muscle tone, decreased body fat, improved energy levels, a reduction in stress, and improved cardiac output. Once again, congratulations, you are on your way to improving your self image, overall health and quality of life.

## **BEFORE ASSEMBLING YOUR HOME GYM**

**IMPORTANT:** Read this entire manual before attempting to build or use this machine. This manual contains step by step instructions for proper assembly.

Use the parts list included in this manual to verify that all parts are accounted for before assembly. If any parts are missing, contact the retailer of this home gym for replacement parts. Or, call Inspire at 877-738-1729.

Make sure that adequate room has been cleared before attempting to build your home gym. A rubber mat is recommended for use under your home gym to protect wood flooring or carpeting from damage during assembly and usage.

This home gym is intended for indoor use only. In addition, garages and screened in porches are not recommended due to high humidity or dust. Certain parts including guide rods can form rust in a humid environment, resulting in impaired function.

Service of your home gym should only be performed by an authorized Inspire Fitness retailer. Service performed by anyone else can result in loss of warranty. If you need help finding an authorized retailer, please contact us directly:

Inspire Fitness  
4945 East Hunter Avenue  
Anaheim, CA 92807  
Ph: 877-738-1729  
Fx: 714-738-1728  
[www.inspirefitness.net](http://www.inspirefitness.net)

# TABLE OF CONTENTS

<b>Section Description.....</b>	<b>Page</b>
Important Safety Instructions.....	1
Tools Required.....	1
Parts List.....	2
Cable Chart .....	3
Assembly Instructions.....	4
Decal Reference.....	29
Decal Placement.....	31
Accessories.....	32
General Maintenance Information.....	33
Maintenance Schedule.....	34
Limited Warranty.....	35

## **IMPORTANT SAFETY INSTRUCTIONS**

Please read this entire manual and familiarize yourself with all decals and warnings before using this multi-gym.

- **WARNING!** It is necessary to inspect this multi-gym regularly to maintain safety and proper function. Please use the maintenance schedule included towards the back of this manual. Immediately replace any and all defective or worn parts. Pay special attention to moving parts such as the cables and pulleys and connections to accessories. See General Maintenance section for complete details.
- Use this multi-gym for its intended purpose as described in this Operation Manual or the exercise chart. Do not use attachments not recommended by the manufacturer.
- **Do not hang from press arm. The press arm is not designed to support human weight.**
- Make sure bystanders are at least 5 feet away from the multi-gym while it is in use.
- Keep children off the multi-gym at all times.
- Keep the multi-gym away from walls and clear of any obstructions and furniture.
- Stop immediately if you experience shortness of breath, pain, or dizziness during your workout. Inspire strongly recommends consulting your doctor before starting an exercise program.

## **TOOLS REQUIRED FOR ASSEMBLY**

- Metric socket set (including 17mm, 18mm, and 19mm sockets)
- Metric 17mm, 18mm, and 19mm wrenches
- 6mm, 5mm, 4mm, and 3mm Allen wrenches (supplied in the hardware packs)
- Adjustable wrench
- Metric Tape Measure
- Rubber Mallet

# M3 PARTS & HARDWARE LIST

Item	Parts Description	Qty	Qty Rec'd
1	Main Upright	1	
2	Rear Base	1	
3	Seat Base Frame	1	
4	Upright Support, Right	1	
5	Upright Support, Left	1	
6	Ab Frame Assy.	1	
7	Ab Arms	2	
8	Backpad Support Frame	1	
9	Backpad Mount	1	
10	Seat Stem	1	
11	Top Beam Plate, Left	1	
12	Top Beam Plate, Right	1	
13	Press Arm Center support	1	
14	Upper swivel Pulley Assy.	1	
15	Press Arm Mount, Left	1	
16	Press Arm Mount, Right	1	
17	Press Arm, Left	1	
18	Press Arm, Right	1	
19	Leg Extension Assy.	1	
20	Leg Extension Cam	1	
21	Backer Plate	1	
22	Swivel Pulley Mount	1	
23	Swivel Pulley Bracket	1	
24	Lower Guide Rod Mount	1	
25	Guide Rod	2	
26	Shroud Plate	1	
27	Shroud Plate Assembly	1	
28	Adjustable Floating Pulley Assy.	1	
29	Floating Double Pulley Assy.	1	
30	Floating Pulley Bracket Assy.	1	
31	Pulley Cover Plates	2	
32	Top Weight/Selector Stem	1	
33	Top Wt Pulley Bracket w/ nut	1	
34	Weight Stack Number	1	
35	Rubber Donut	2	
36	Roller Pad w/out Extension	4	
37	Roller Pad with Extension	2	
38	Thigh Pads	2	
39	Large Plastic Washer	4	
40	Seat Base	2	
41	Head Pad	1	
42	Upper Cable	1	
43	Middle Cable	1	
44	Leg Extension Cable	1	
45	Ab Cable	1	
46	Revolving Aluminum Curl Bar	1	
47	D handle/Ab Strap	4	
48	Ankle Strap	1	
49	Guide Rod Lube	2	
50	Touch-up Paint	2	
51	Wall Chart	1	
52	Curl Bar Holder	2	

Item	Parts Description	Qty	Qty Rec'd
53	4 1/2" Pulley Cover Plate	1	
54	3 1/2" Pulley	8	
55	4 1/2" Pulley	1	

Item	Hardware Description	Qty	Qty Rec'd
1	Bolt, M8 x 15 L	8	
2	Bolt, M10 x 25 L (Flat Head )	6	
3	Bolt, M10 x 25 L	5	
4	Bolt, M10 x 45 L	11	
5	Bolt, M10 x 50 L	10	
6	Bolt, M10 x 60 L	4	
7	Bolt, M10 x 70 L	2	
8	Bolt, M10 x 95 L	2	
9	Bolt, M10 x 100 L	1	
10	Bolt, M10 x 105 L	2	
11	Bolt, M10 x 150 L	2	
12	Bolt, M10 x 155 L	2	
13	Bolt, M12 x 85 L	1	
14	Bolt, M12 x 95 L	2	
15	Bolt, M12 x 110 L	1	
16	M12 Press Arm Shaft	1	

17	M8 Washer	8	
18	M10 Washer	66	
19	M12 Washer	9	
20	M12 Hat Washer	4	
21	M12 Washer, Large OD	2	

22	M6 T-Nut	4	
23	M10 Locknut	22	
24	M12 Locknut	5	
25	M12 Thin Locknut	3	

26	Barrel Spacer, 9/16" Long	2	
27	Plastic Spacer Tube	2	
28	Plastic Dome Caps	4	
29	Aluminum Endcaps	6	
30	Cable Adapter	2	
31	Spring Clip	5	
32	Chain	1	
33	Weight Pin	1	
34	3 mm Hex Wrench	1	
35	4 mm Hex Wrench	1	
36	5 mm Hex Wrench	2	
37	6 mm Hex Wrench	1	
38	Cable Ball	4	
39	Cable "U" Bracket	4	
40	Shroud Plate Connector Pins	6	

## M3 CABLE CHART

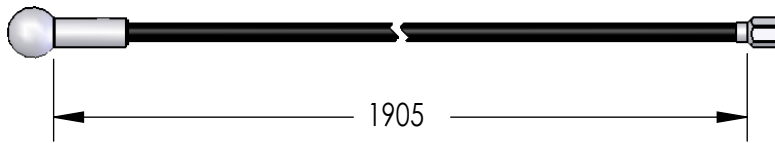

LEG EXTENSION CABLE  
870-500-002

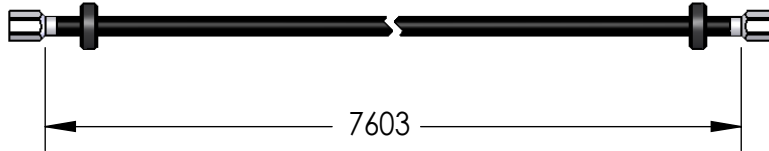

UPPER CABLE  
873-500-



MIDDLE CABLE  
873-500-

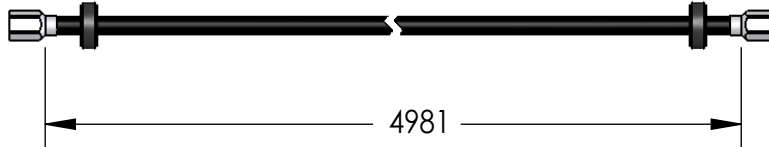

AB CABLE  
873-500-

Cable lengths are in millimeters and for reference only.  
Cable lengths could change at any time without notice.

M3 rev2013  
121913

# ASSEMBLY INSTRUCTIONS

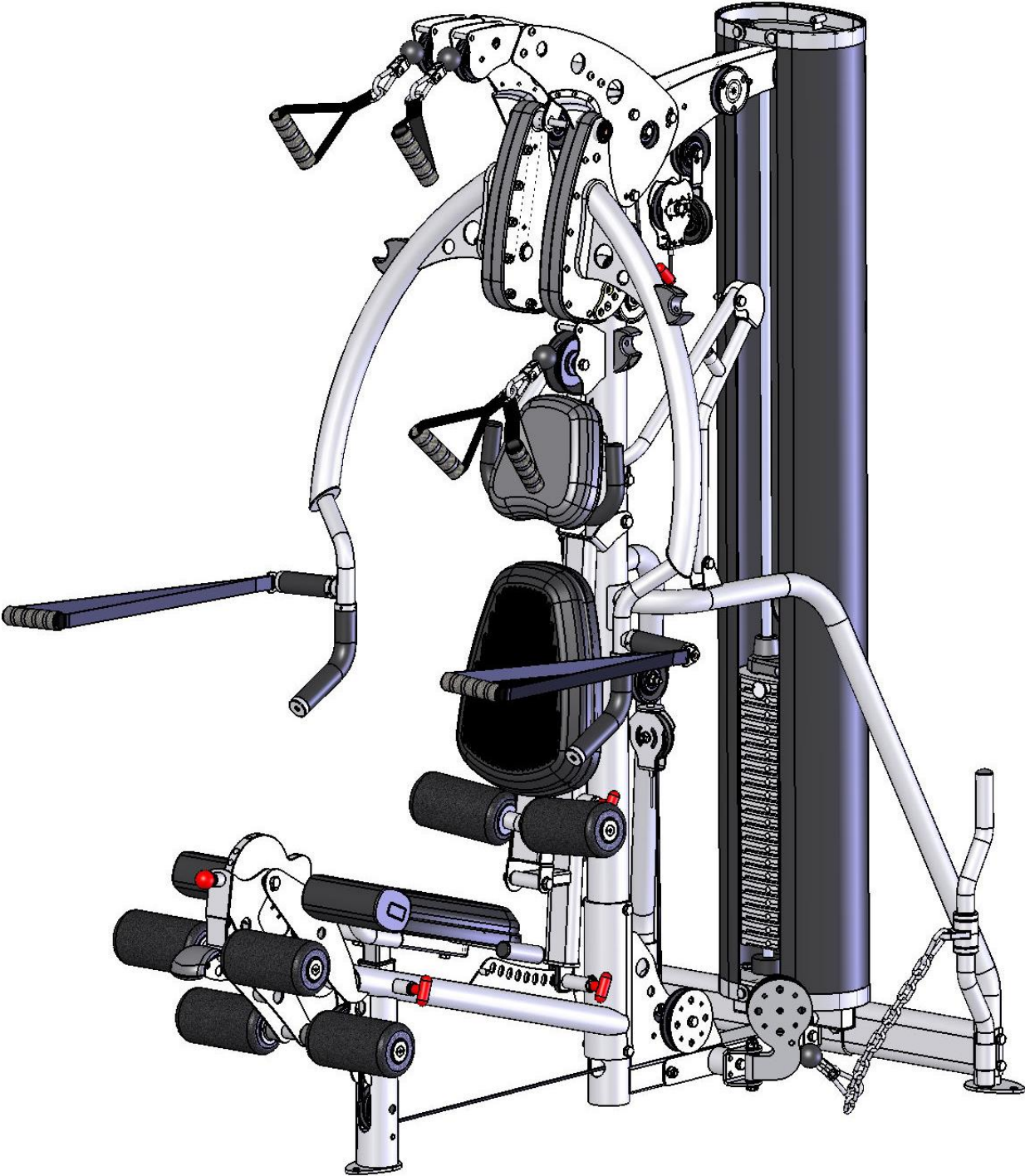

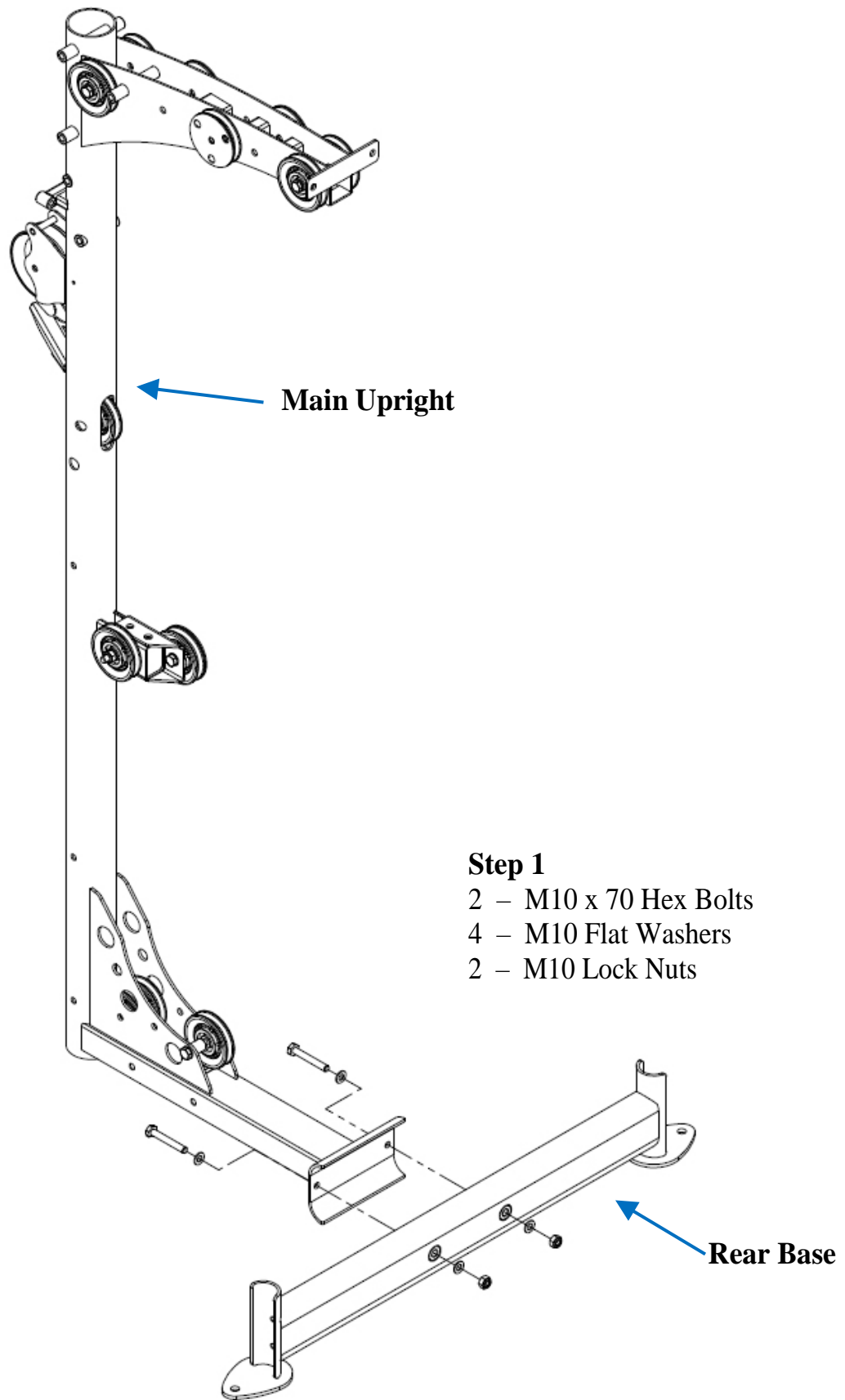

**Step 1:** Attach Rear Base to Main Upright.

**Note: Finger Tighten Only!**



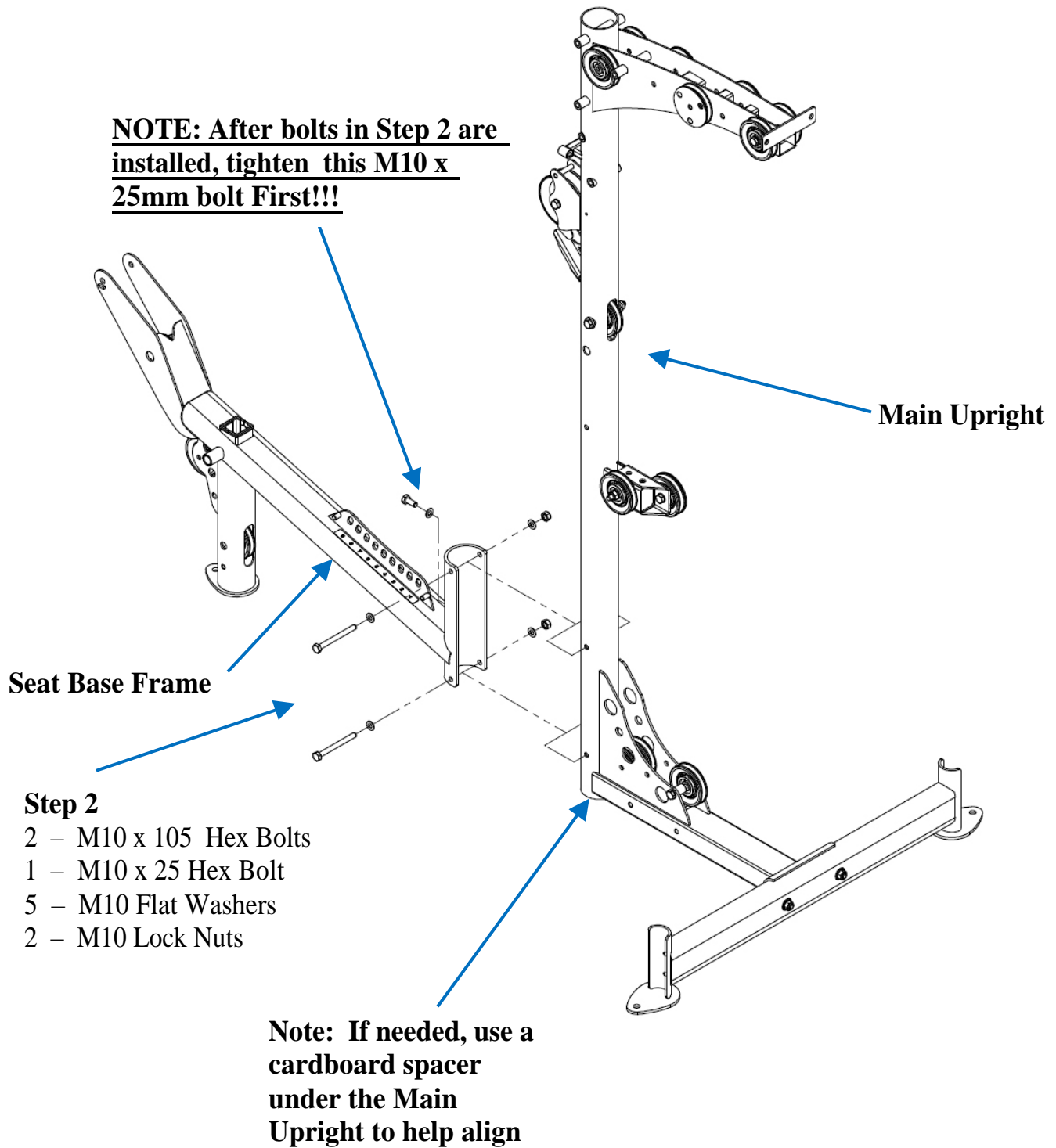

**Step 2:** Attach Seat Base Frame to Main Upright.

**NOTE:** Tighten the 25mm Hex Bolt first, then the two 105mm Hex Bolts in Step 2.

**HINT:** For ease of assembly, place a ½” wood block or folded cardboard under the Main Upright before installing bolts.

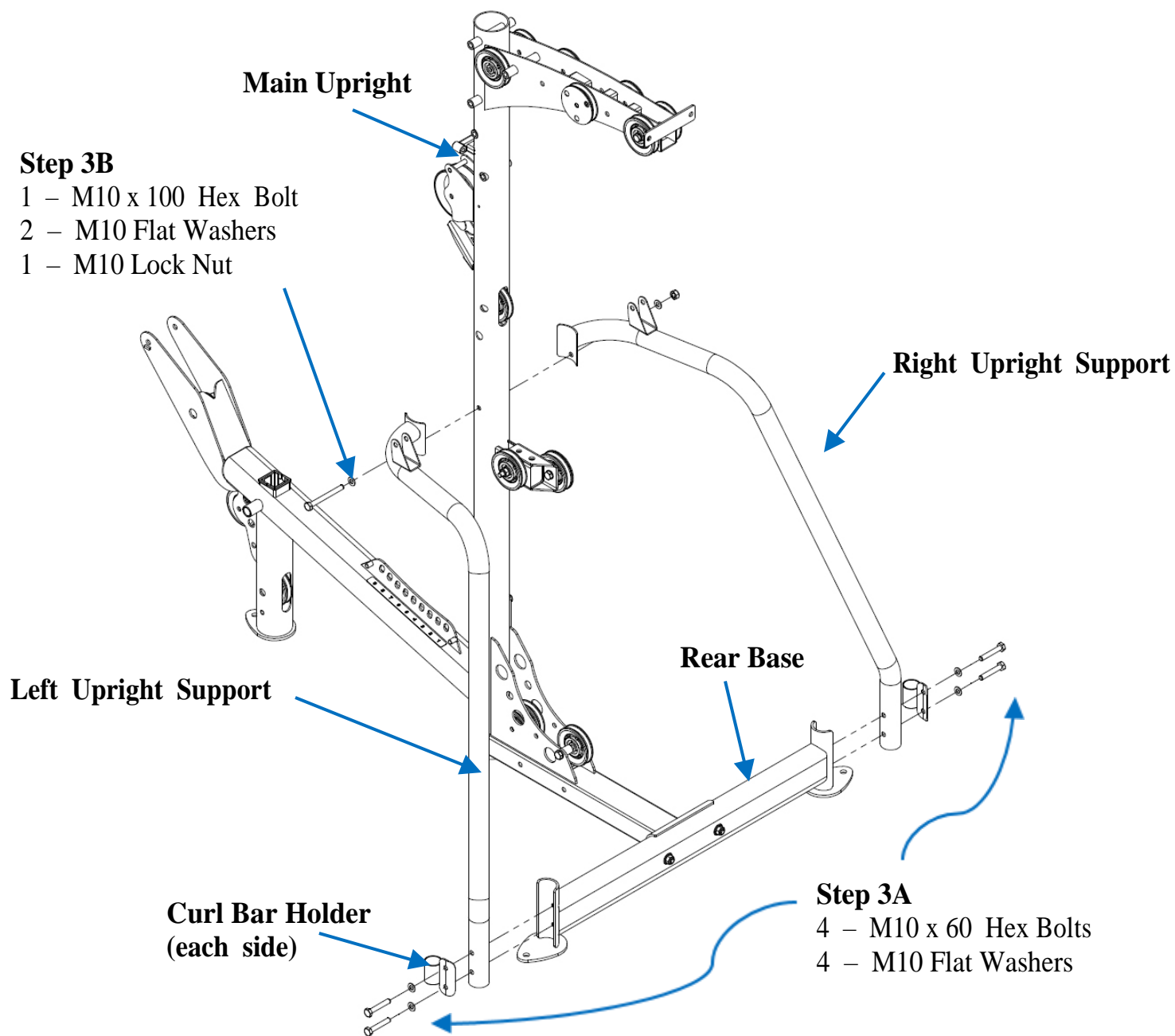

**Step 3A:** Attach Left Upright Support, Right Upright Support, and Curl Bar Holders to Rear Base.

**Step 3B:** Attach Left and Right Upright Supports to Main Upright.

**Next, tighten the bolts in Step 1 (Rear Base to Main Upright), then tighten bolts in Steps 3A and 3B.**

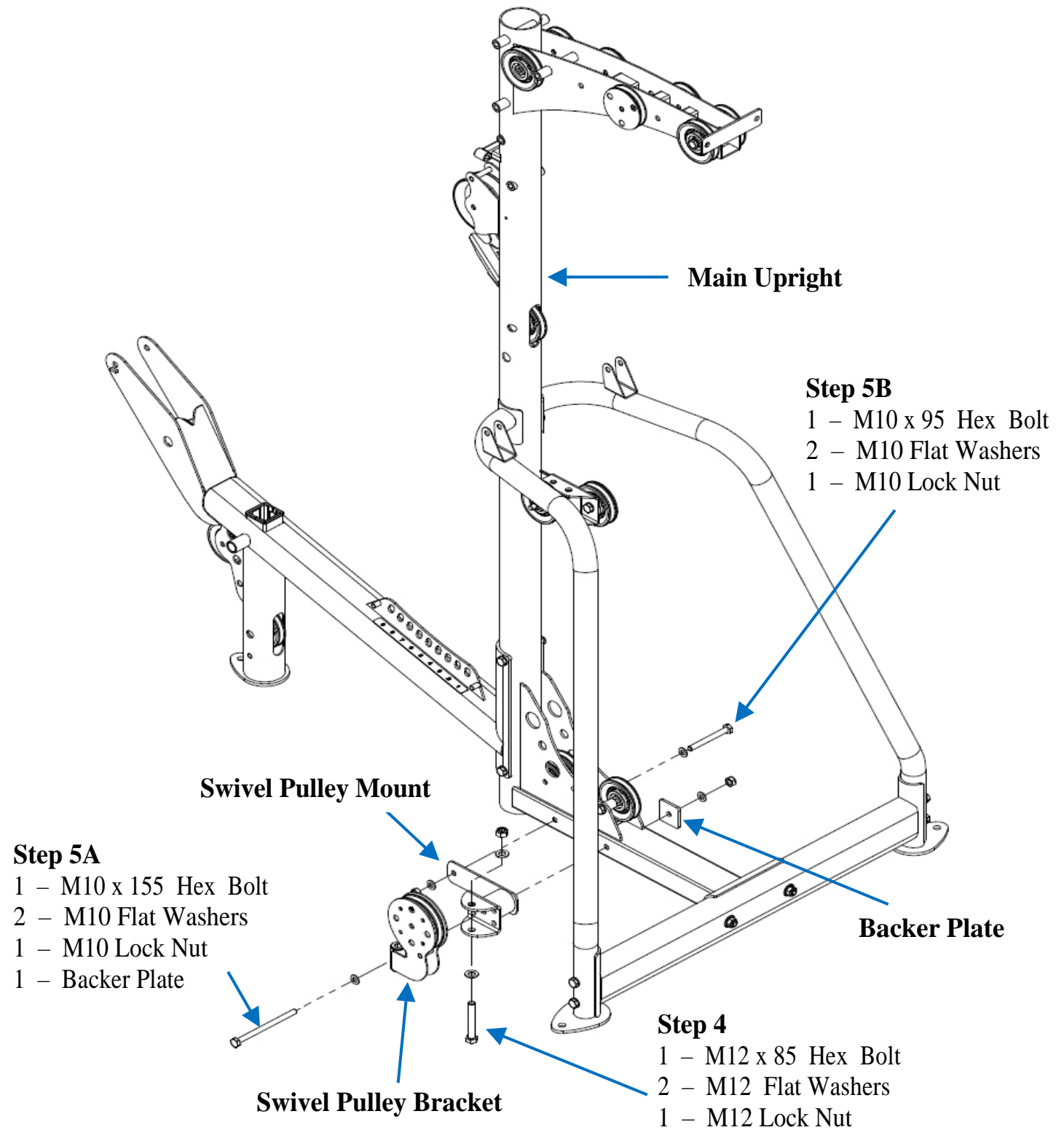

**Step 4:** Attach Swivel Pulley Bracket to Swivel Pulley Mount (insert bolt from bottom).

**NOTE:** Insert M10 x 155 Hex Bolt and Washer into Swivel Pulley Mount in direction shown before attaching Swivel Pulley Bracket to Swivel Pulley Mount.

**Tighten M12 Bolt now so that the Pulley Bracket swivels in the Mount.**

**Step 5A & 5B:** Attach Swivel Pulley Mount to Main Upright. Feed bolts as shown. **Tighten Now.**

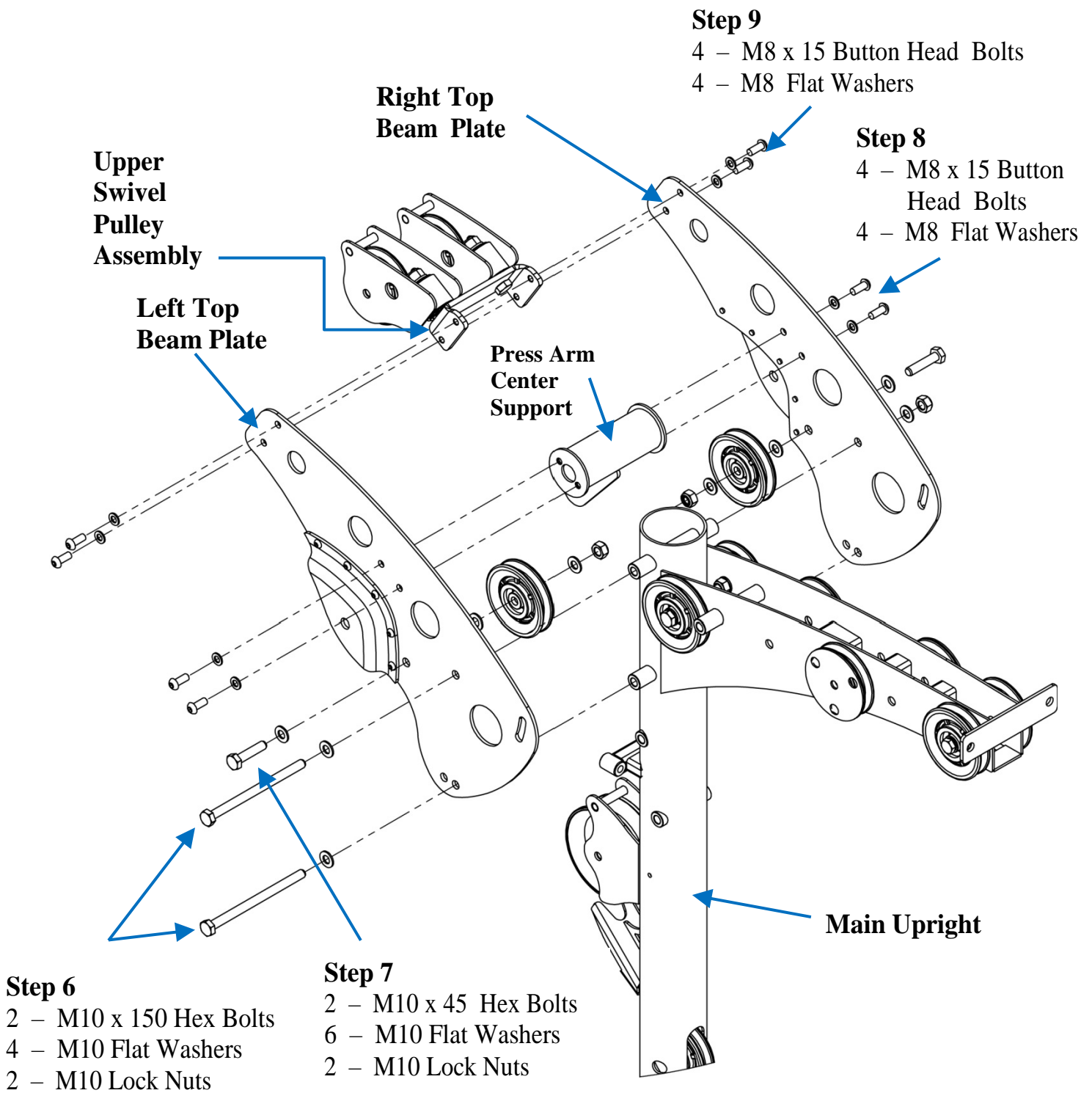

**Step 6:** Attach Left and Right Top Beam Plates to Main Upright. **Finger Tighten Only!!**

**Note:** This shows the high position for the lat pull. Use front hole of bottom 150 bolt for lower position.

**Step 7:** Attach 2 Pulleys to Top Beam Plates. Place a Washer between each Pulley and each Top Beam Plate. **Tighten Now!**

**Step 8:** Attach Press Arm Center Support between the Top Beam Plates. **Finger Tighten Only!!**

**Step 9:** Attach the Upper Swivel Pulley Assembly between the outer ends of the Top Beam Plates. **Finger Tighten Only!!**

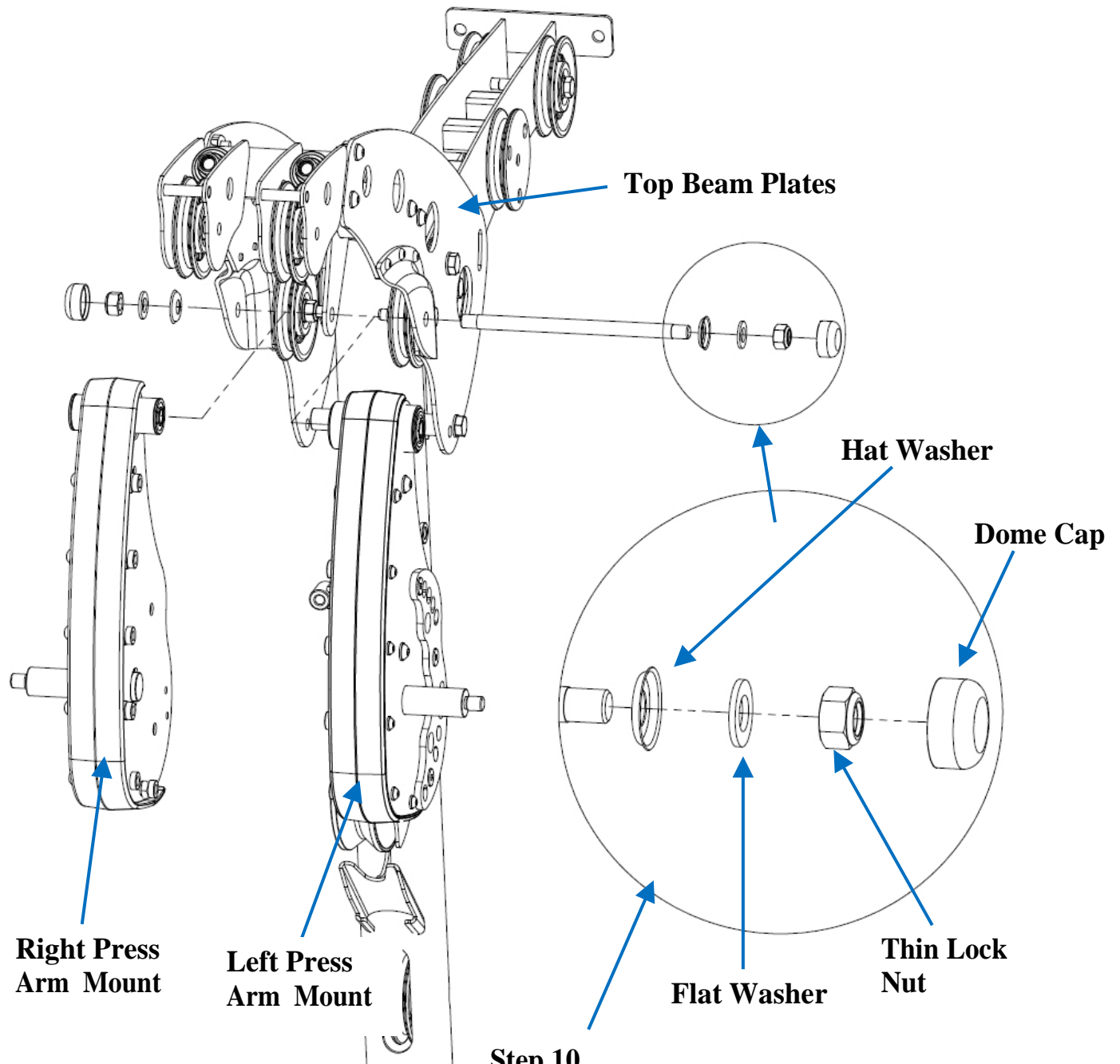

**Step 10**

- 1 – M12 Press Arm Shaft
- 2 – M12 Hat Washers
- 2 – M12 Flat Washers
- 2 – M12 Thin Lock Nuts
- 2 – Plastic Dome Caps

**Step 10:** Attach the Left and Right Press Arm Mounts to the Top Beam Plates. The Press Arm Shaft should go through the hole on the flange of the Press Arm Center Support. **Finger Tighten Only!!**

**NOTE:** Hat Washers must be attached as shown to avoid damage to the Hat Washers. Do not attach Dome Caps until Step 35.

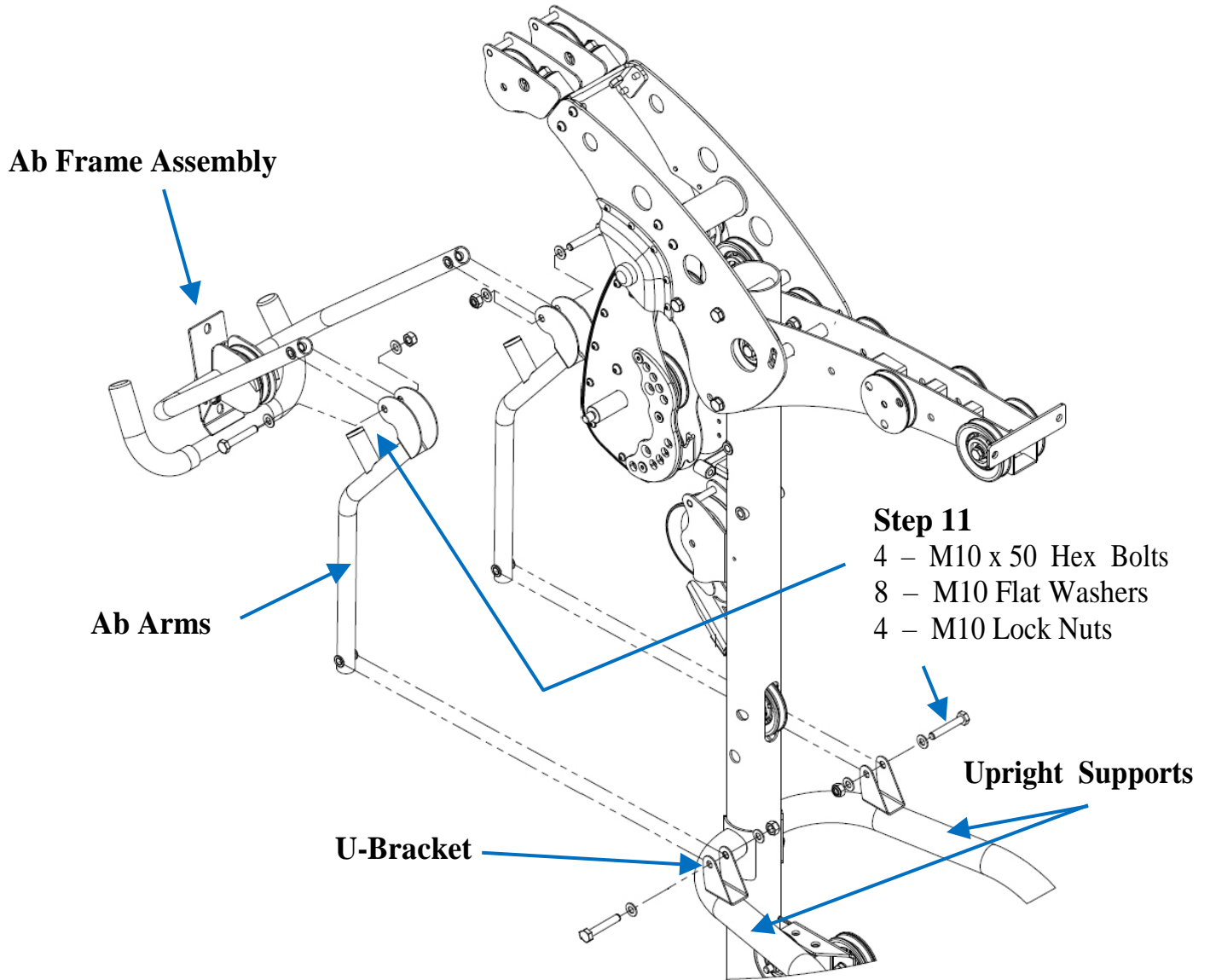

**Step 11:** Attach both Ab Arms to the Ab Frame Assembly, then attach this assembly to the U-Bracket's on the Upright Supports. **Tighten so each joint so they pivot freely!!!**

**Bolt Head must fit snug against Anti-Rotation Tab**

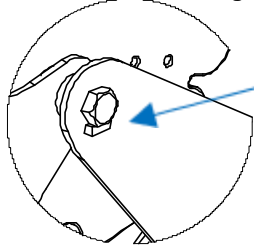

**STEP 13**

- 1 – M12 x 95 Hex Bolt
  - 1 – M12 Flat Washers
  - 1 – M12 Thin Lock Nut
- Note: washer on nut side only.*

**NOTE:** If small cable end won't fit between pre-assembled Pulleys, loosen or remove Lower Pulley, insert cable end between the Upper Pulley and the metal plate, then re-attach the Lower Pulley.

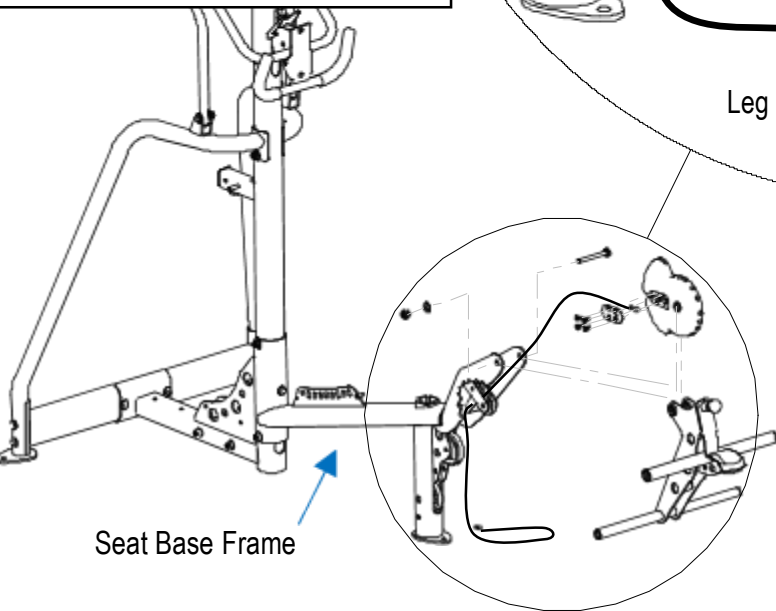

**STEP 12**

- 4 – M6 Flat Head Cap Screws
- 1 – Cam Plate



This large Ball End to be attached to L/E Cam as shown above.

Step 12: Begin by removing the 4 Flat Head Cap Screws and the Cam Plate from the Leg Extension Cam (L/E Cam). Next, using these same 4 Flat Head Cap Screws and the Cam Plate, attach the Leg Extension cable to the L/E Cam, as shown in the above diagram.

Step 13: Attach L/E Cam and L/E Assembly to Seat Base. **NOTE:** Washer on nut side only. **NOTE:** Be sure to thread Leg Extension Cable through pre-assembled pulleys as L/E Cam and L/E Assembly are attached.

**NOTE: Tighten Now, Do Not Over Tighten. L/E Assembly should swivel freely.**

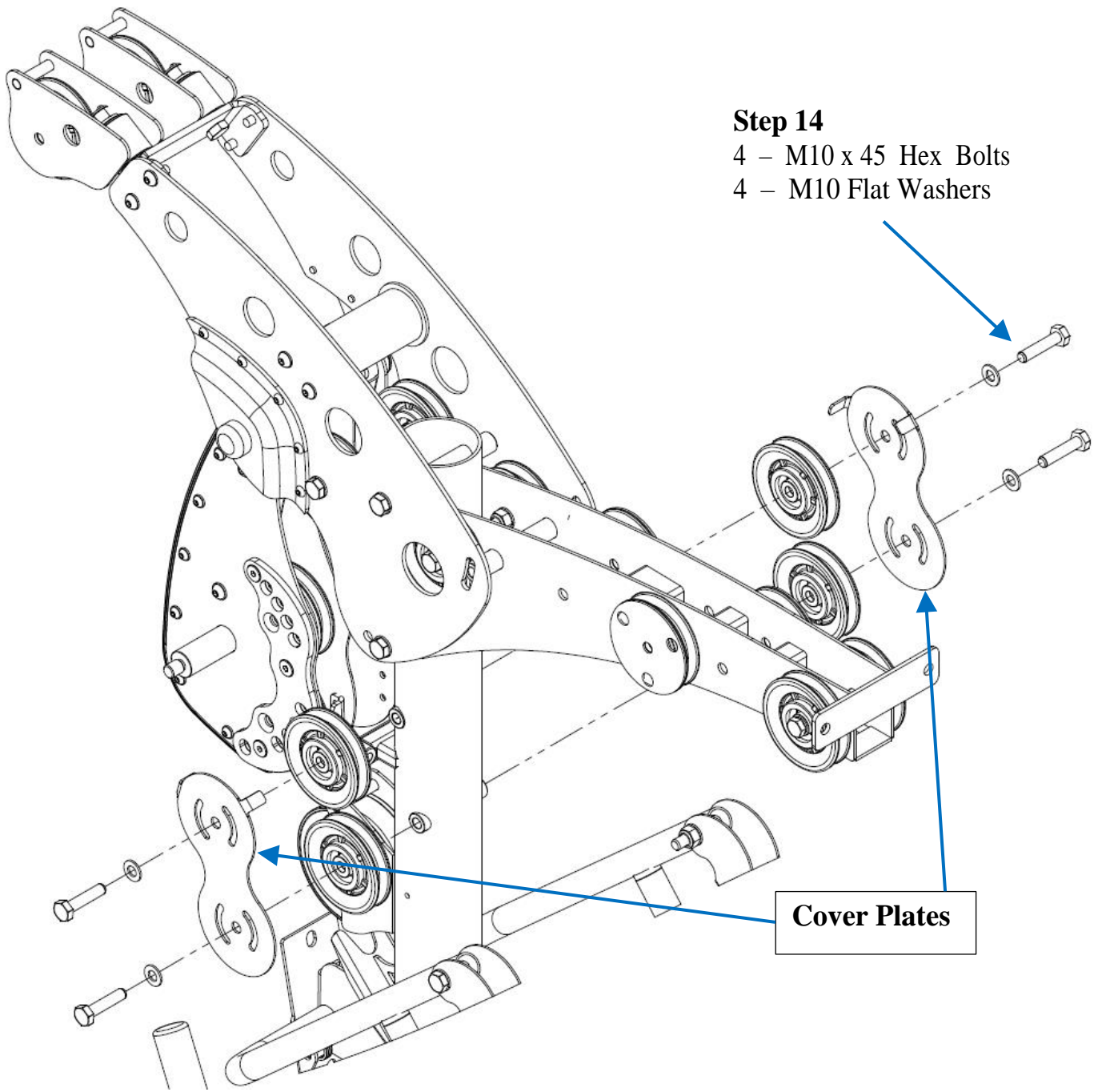

**Step 14:** Attach two 3 ½" pulleys and cover plate to the threaded stubs on each side of the Main Upright. **Tighten now!**



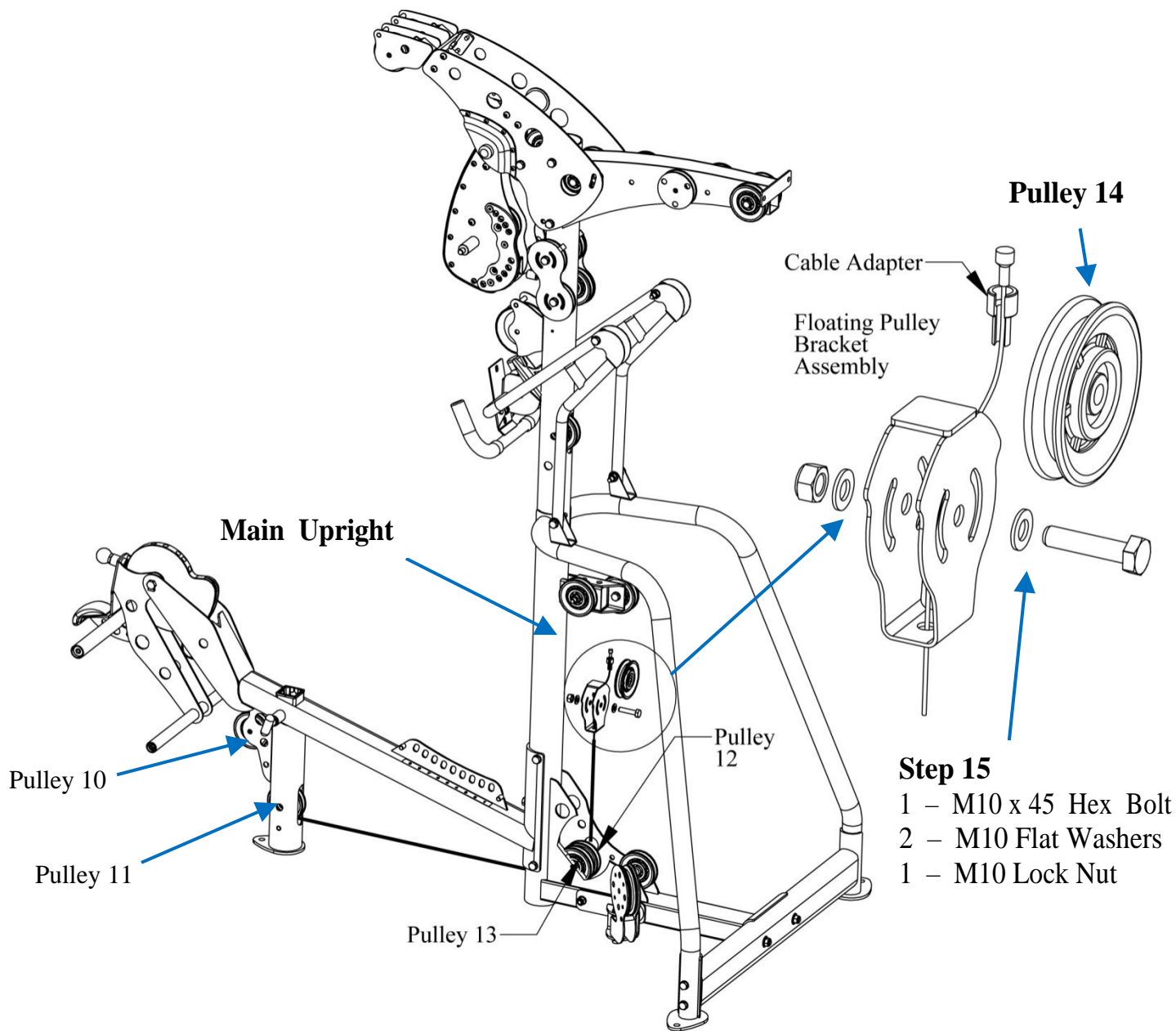

**Step 15:** Bring the L/E Cable from the two small pulleys under the Cam, over and behind Pulley 10, down in front of and under Pulley 11 (make sure the cable is between the pulleys and the cable retainer pins), back through hole in bottom of Main Upright, under Pulley 13 (on the left as sitting on machine) and attach to Floating Pulley Bracket Assembly using the Cable Adapter. Seat Cable and Cable Adapter into hole at bottom of the Floating Pulley Bracket. Next insert pulley 14 into the bracket and secure. **Tighten now!** This may be preassembled, if so, take the pulley out of Bracket and reassemble after cable is inserted.

**Note:** If you purchased the Leg Press Option, these instructions position it on the Right Hand side of the machine. If you would like it on the Left Hand side, go to [www.inspirefitness.net](http://www.inspirefitness.net) to download the addendum.

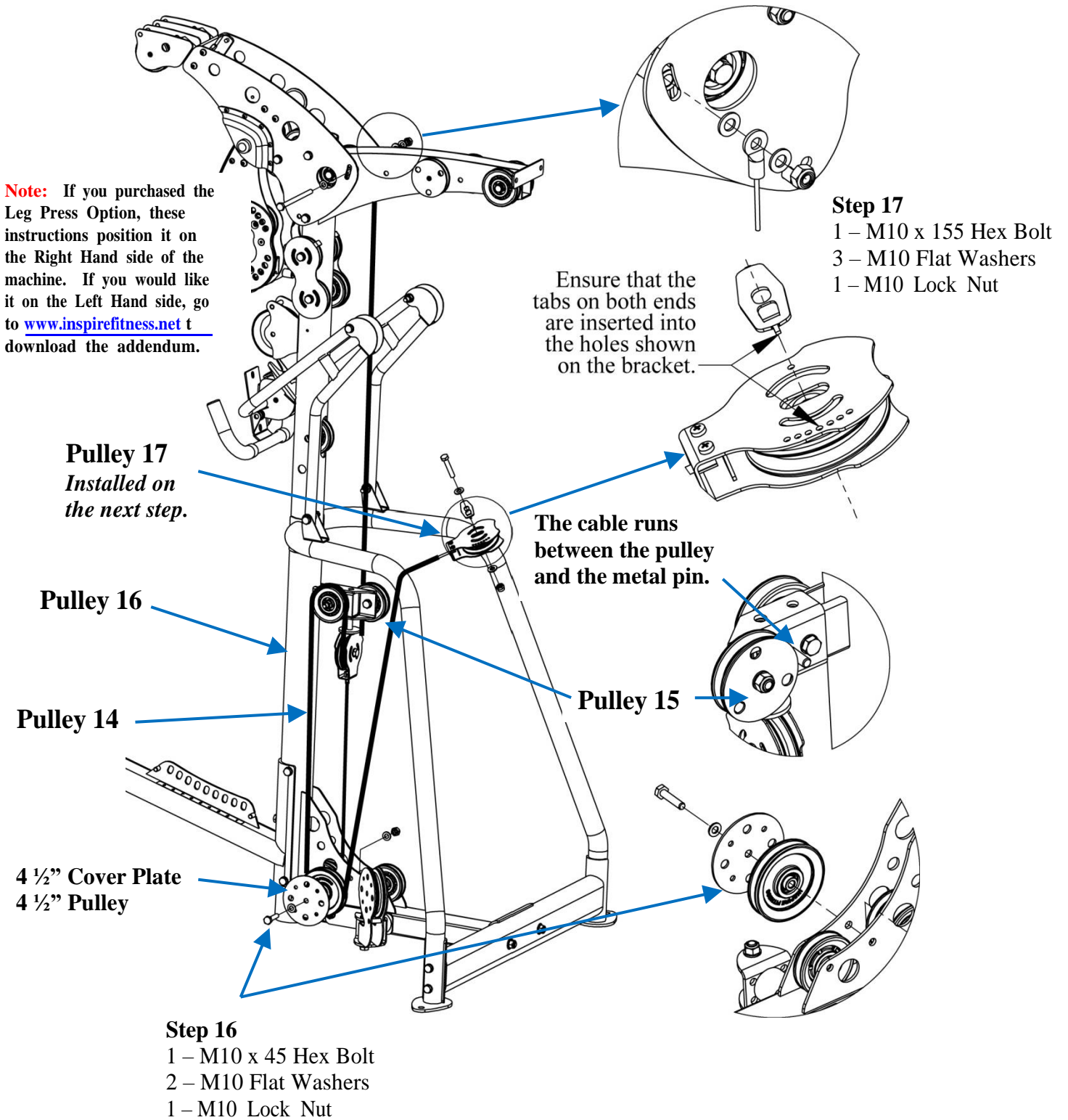

**Pulley 17**  
Installed on the next step.

**Pulley 16**

**Pulley 14**

**4 1/2" Cover Plate**  
**4 1/2" Pulley**

**Step 16**

- 1 – M10 x 45 Hex Bolt
- 2 – M10 Flat Washers
- 1 – M10 Lock Nut

**Step 17**

- 1 – M10 x 155 Hex Bolt
- 3 – M10 Flat Washers
- 1 – M10 Lock Nut

Ensure that the tabs on both ends are inserted into the holes shown on the bracket.

The cable runs between the pulley and the metal pin.

**Pulley 15**

**Step 16:** Attach a 4 1/2" Pulley and 4 1/2" Cover Plate to the base of the Main Upright as shown. **Tighten Now.**  
**Step 17:** Use the Middle Cable with the hole in one eyelet end. Attach eyelet end with hole to the right side, Top Beam Plate. Make sure a washer is on each side of the eyelet end as shown. **Finger tighten only.** Next, route the cable down between Pulley 15 and the retainer pin, under Pulley 14 and up over Pulley 16 towards the front and then down under the 4 1/2" Pulley towards the back, then up and attach the end in the Adjustable Floating Pulley Bracket (with Pulley 17) by taking one screw of the L retainer out and loosening the other screw, tilting the L retainer and slipping cable end through the hole in the bottom of the bracket and securing with the Cable Adapter back in the hole. Next replace L bracket and **Tighten both Screws!!** Set Pulley 17 Bracket aside to be used in the next step.

**Upper Cable:** This section of cable loops down and back up to the other side to continue. This loop will attach to the weight stack pulley later.

**Note: Make sure to route Cable above the press arm stop.**

Left side when sitting on machine.

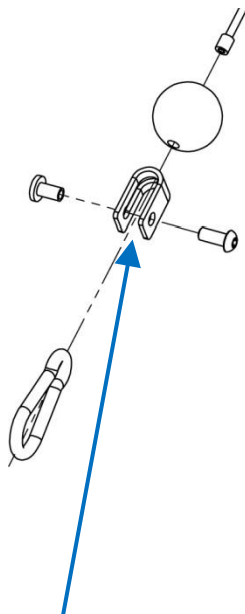

Make sure to route the cable between the pulley and the barrels pointed out by the arrows

Pulley 17  
Adjustable Floating Pulley Assembly

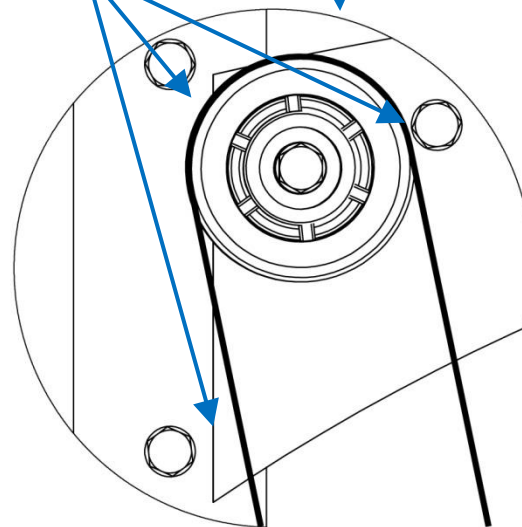

**Step 18**

- 1 – Plastic Ball
- 1 – Cable “U” Bracket
- 1 – M6 x 12 Button Head Bolt
- 1 – Spring Clip
- 1 – M6 T Nut

**Step 18:** Assemble one end of Upper Cable by sliding the plastic ball onto the end of the cable. Next slide the cable end into the side of the U bracket and to the bottom of the U. Attach Spring Clip to U bracket using Button Head Bolt and T nut as shown. Slide the rubber washer against the ball. If both ends are assembled, take one end apart.

Start at one of the lat swivel pulleys (Note if it is the Left or Right side when sitting in the machine. Feed the unassembled end of the cable around pulleys as shown for that side of the machine (may help to slide the rubber washer back 10” (25cm) to feed through press arm mounts). Let a loop hang down in back for use with the weight stack and then continue to route the other side of the machine from back to front. *Continue this process on the next page.*

Right side when sitting on machine.

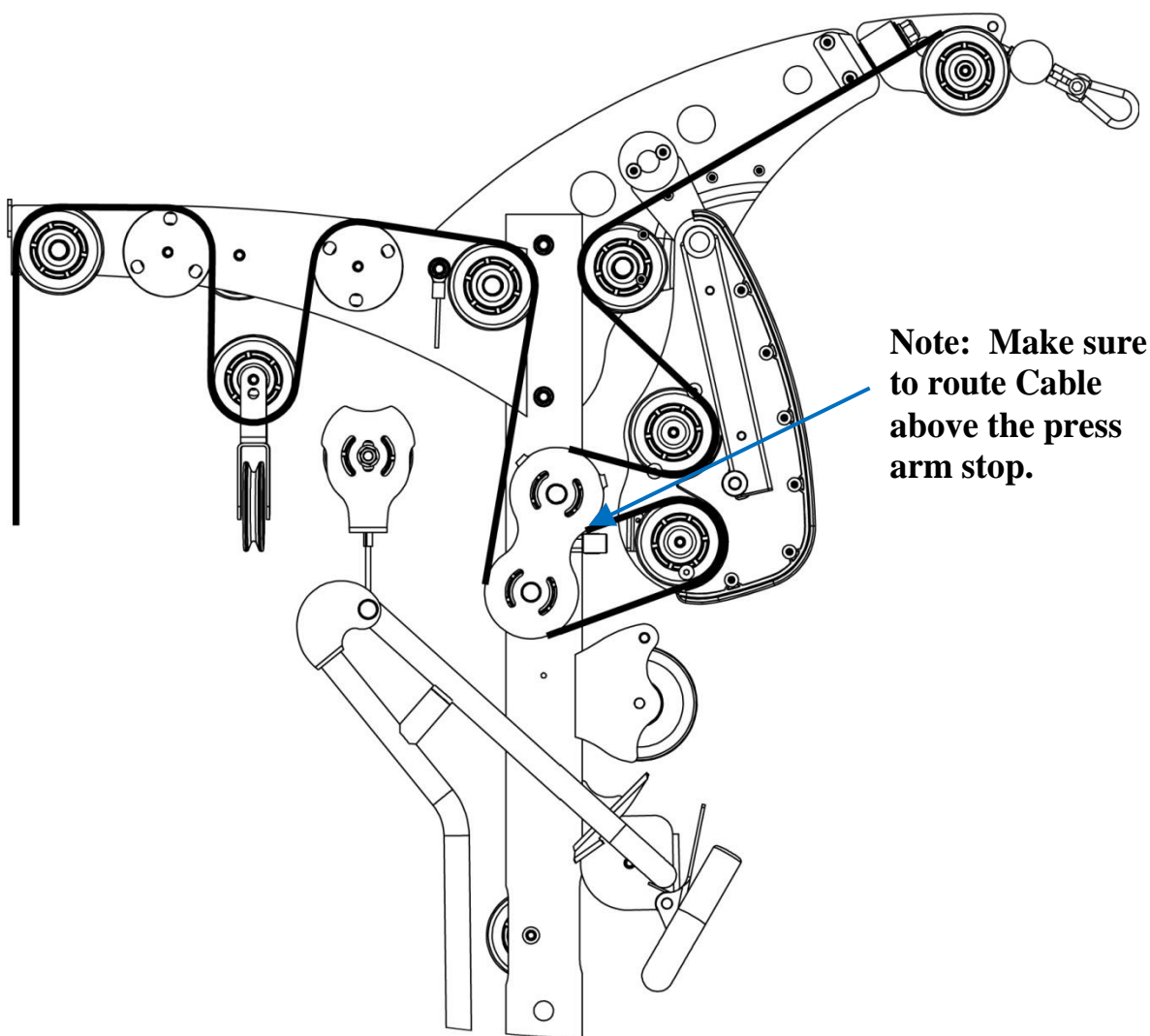

**Step 18:** Rest the 3 ½” pulley in the down loop of the upper cable on the right side of the machine.

When finished feeding out the other lat swivel pulley, assemble the cable end at the start of this step. Slide the rubber washers against each of the plastic balls on the cable ends.

**Tighten both ends of the cable Now.**

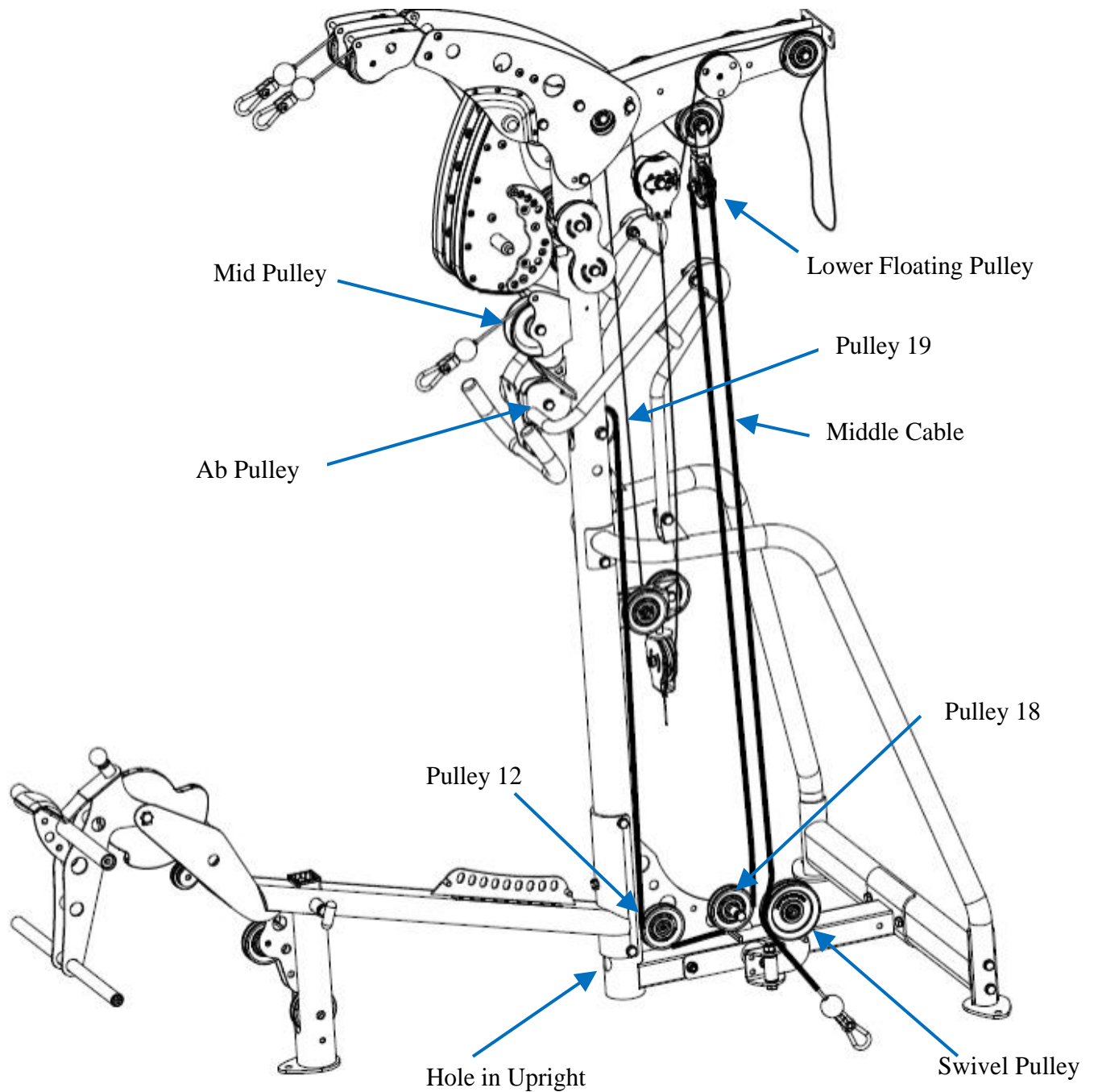

**Step 18b:** Assemble one end of the Middle Cable (as shown in Step 18, page 18) by sliding the plastic ball onto the end of the cable. Next slide the cable end into the side of the U bracket and to the bottom of the U. Attach the Spring Clip to the U bracket using a Button Head Bolt and T nut as shown. Slide the rubber washer against the ball. If both ends are assembled, take one end apart.

Start at the Middle Pulley. Feed the unassembled end of the cable over and behind Mid Pulley, down, in front of and under Ab Pulley, through upright to and over Pulley 19, down in front of Pulley 12. Let cable end sit on base and use a screw driver through the hole in Upright to push the cable end back and under Pulley 12, then under Pulley 18 and up and around the Lower Floating Pulley as shown. Next, go down and under Swivel pulley to outside. Assemble the cable end as at the start of this step. Slide the rubber washers against each of the plastic balls on the cable ends.

**Tighten both ends of the cable Now.**

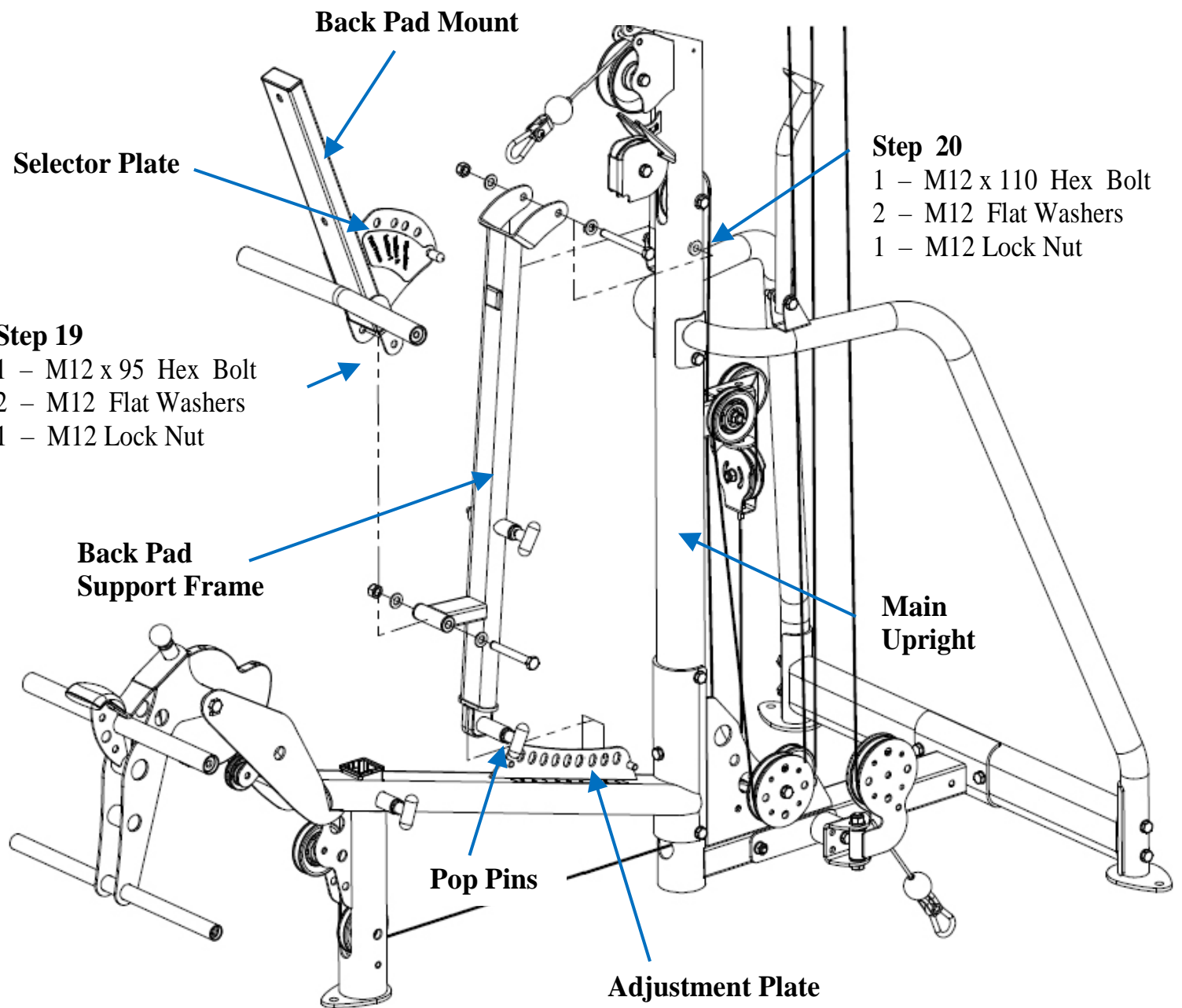

**Step 19:** Attach Back Pad Mount to Back Pad Support Frame (make sure the Pop Pin in the middle of the Back Pad Support Frame is aligned with one of the center holes of the Selector Plate on the Back Pad Mount).  
**Tighten snug so pivots with drag!**

**Step 20:** First, secure the Pop Pin on the bottom of the Back Pad Support Frame to any hole in the Adjustment Plate.

Next, attach Back Pad Support Frame to Main Upright. **Tighten snug so pivots with drag!**

**Note:** To assemble orthopedic pads, place pad on seat base and work the edge of pad into the groove of the seat base on all sides.

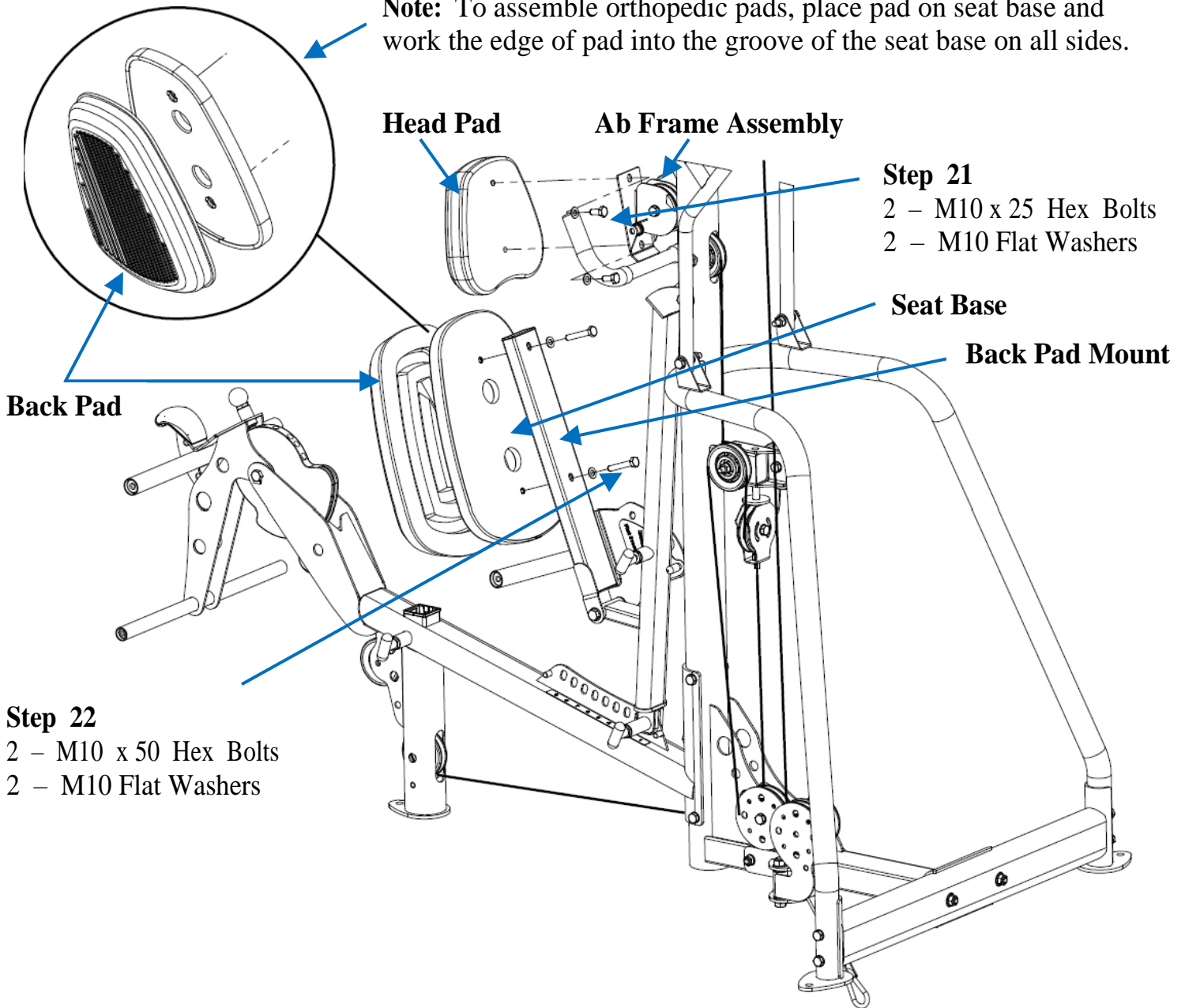

**Step 22**  
2 - M10 x 50 Hex Bolts  
2 - M10 Flat Washers

**Step 21**  
2 - M10 x 25 Hex Bolts  
2 - M10 Flat Washers

**Step 21:** Attach Head Pad to Ab Frame Assembly. **Tighten Now!**

**Step 22:** Attach Seat Base to Back Pad Mount. **Tighten Now!** Insert the Back Pad into Seat Base. **See Note** above.

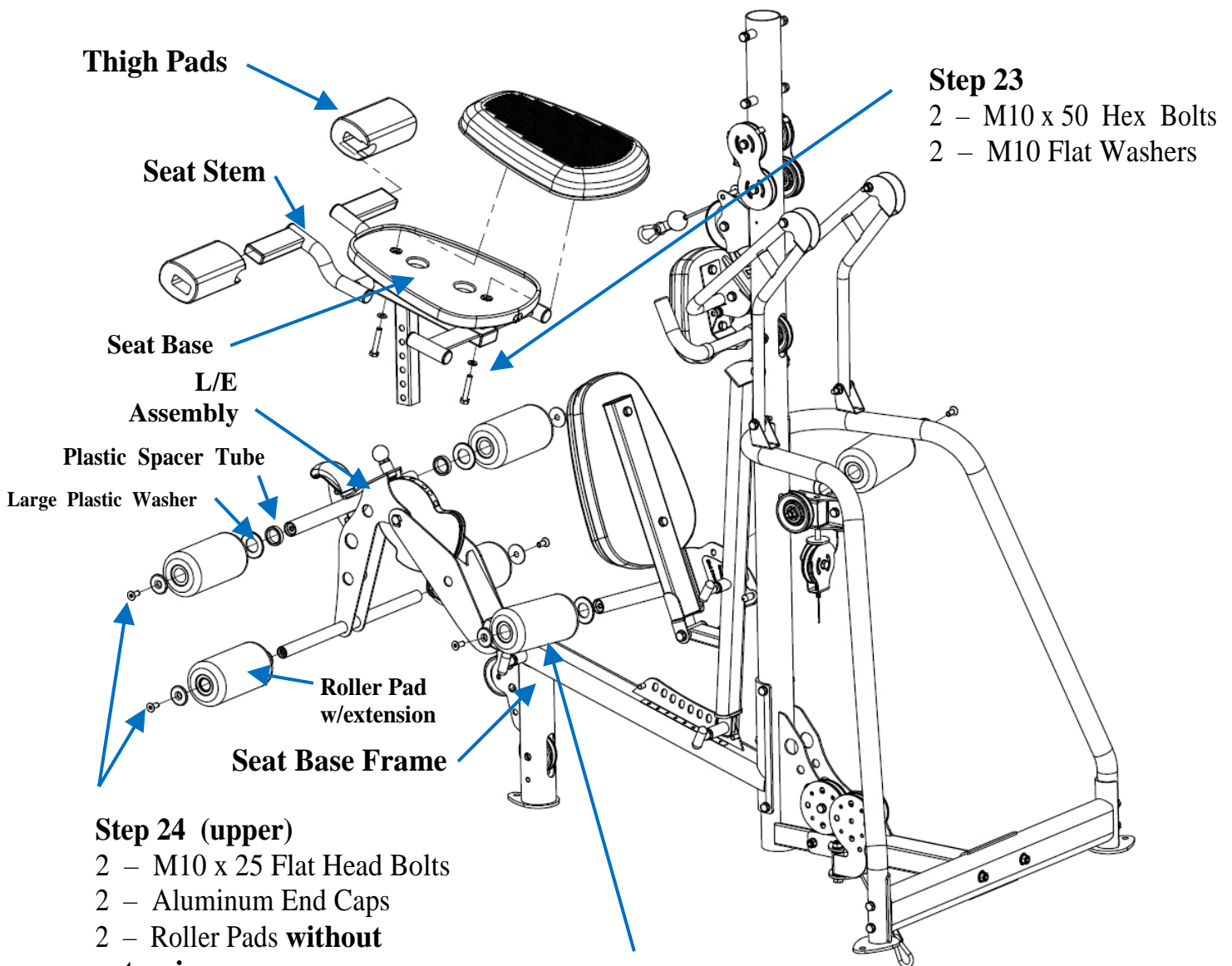

**Step 23**  
 2 – M10 x 50 Hex Bolts  
 2 – M10 Flat Washers

**Step 24 (upper)**  
 2 – M10 x 25 Flat Head Bolts  
 2 – Aluminum End Caps  
 2 – Roller Pads **without extension**  
 2 – Large Plastic Washers  
 2 – Plastic Spacer Tubes

**Step 25 (lower)**  
 2 – M10 x 25 Flat Head Bolts  
 2 – Aluminum End Caps  
 2 – Roller Pads **with extension**

**Step 26**  
 2 – M10 x 25 Flat Head Bolts  
 2 – Aluminum End Caps  
 2 – Roller Pads **without extension**  
 2 – Large Plastic Washers

**Step 23:** Attach Seat Base to Seat Stem. **Tighten Now!** Slide Seat Stem into Seat Base Frame. Insert Orthopedic Pad into Seat Base as Noted in Step 22.

**Step 24:** (Upper Roller Pads) Slide a Plastic Spacer Tube, Large Plastic Washer and Roller Pad on each side of upper L/E shaft. Secure with Aluminum End Caps and Flat Head Bolts as shown. **Tighten Now.**

**Step 25:** Attach lower Roller Pads (with extension on one side) to the L/E Assembly with the Roller Pad extension facing inward. **Tighten Now.**

**Step 26:** Attach Roller Pads to Back Pad Mount. **Tighten Now.**

Next, attach Thigh Pads to Seat Stem by sliding all the way on to rectangular tubes of Seat Stem.



### Step 27

- 2 – Hat Washers
- 2 – M12 Large OD Flat Washers
- 2 – M12 Lock Nuts
- 2 – Dome Caps

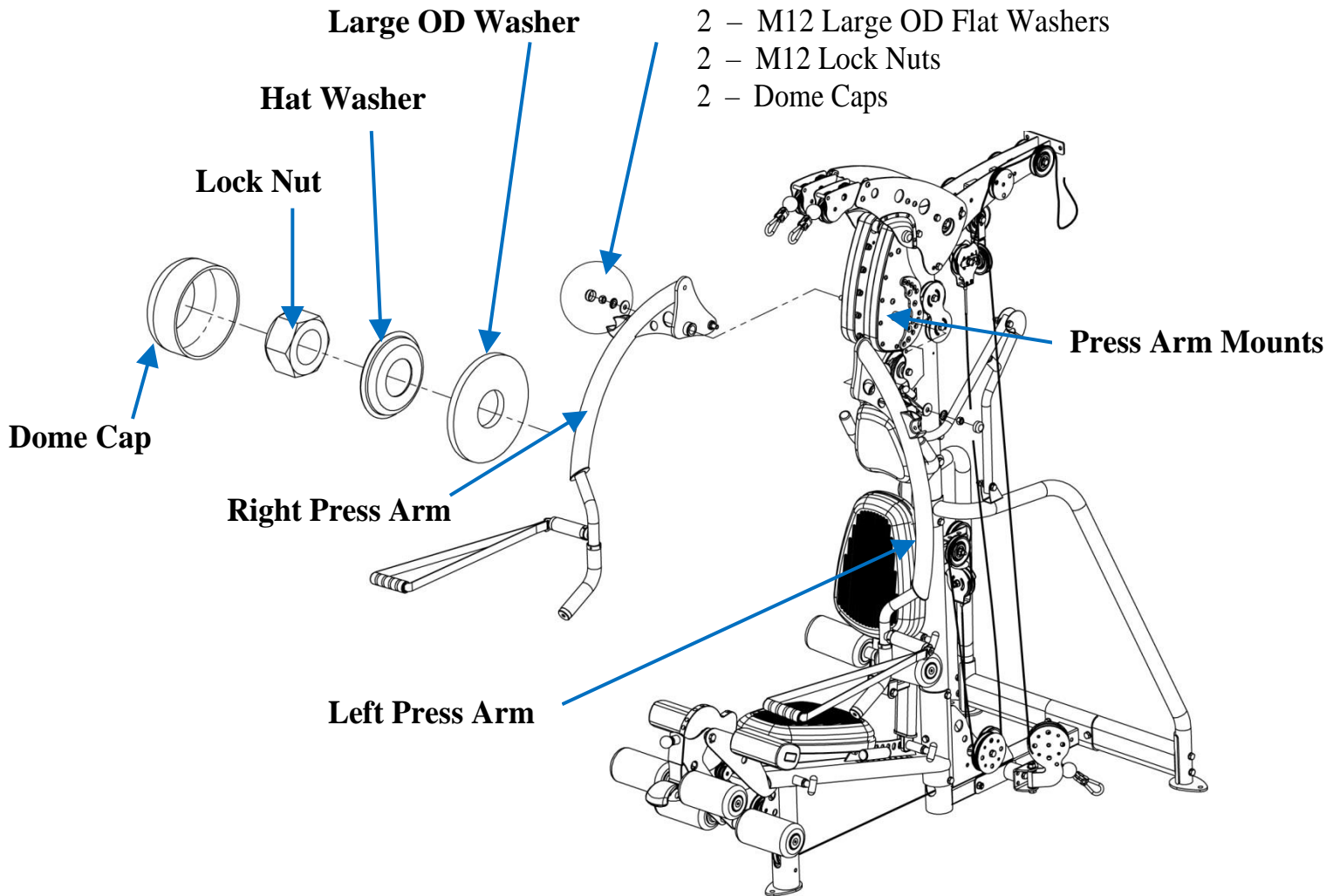

**Step 27:** Slide each Press Arm onto the shaft of its respective Press Arm Mount while aligning the Pop Pin Shaft into a Selector Plate hole. Secure each side with a Large OD Flat Washer, Hat Washer, and M12 Lock Nut. **Tighten until a light resistance is felt when pushing the press arms in and out.**

**NOTE:** Hat Washers must be attached as shown to avoid damage to the Hat Washers.

Next, press a Dome Cap onto each Hat Washer so it covers the shaft end. Make sure it snaps on all around.

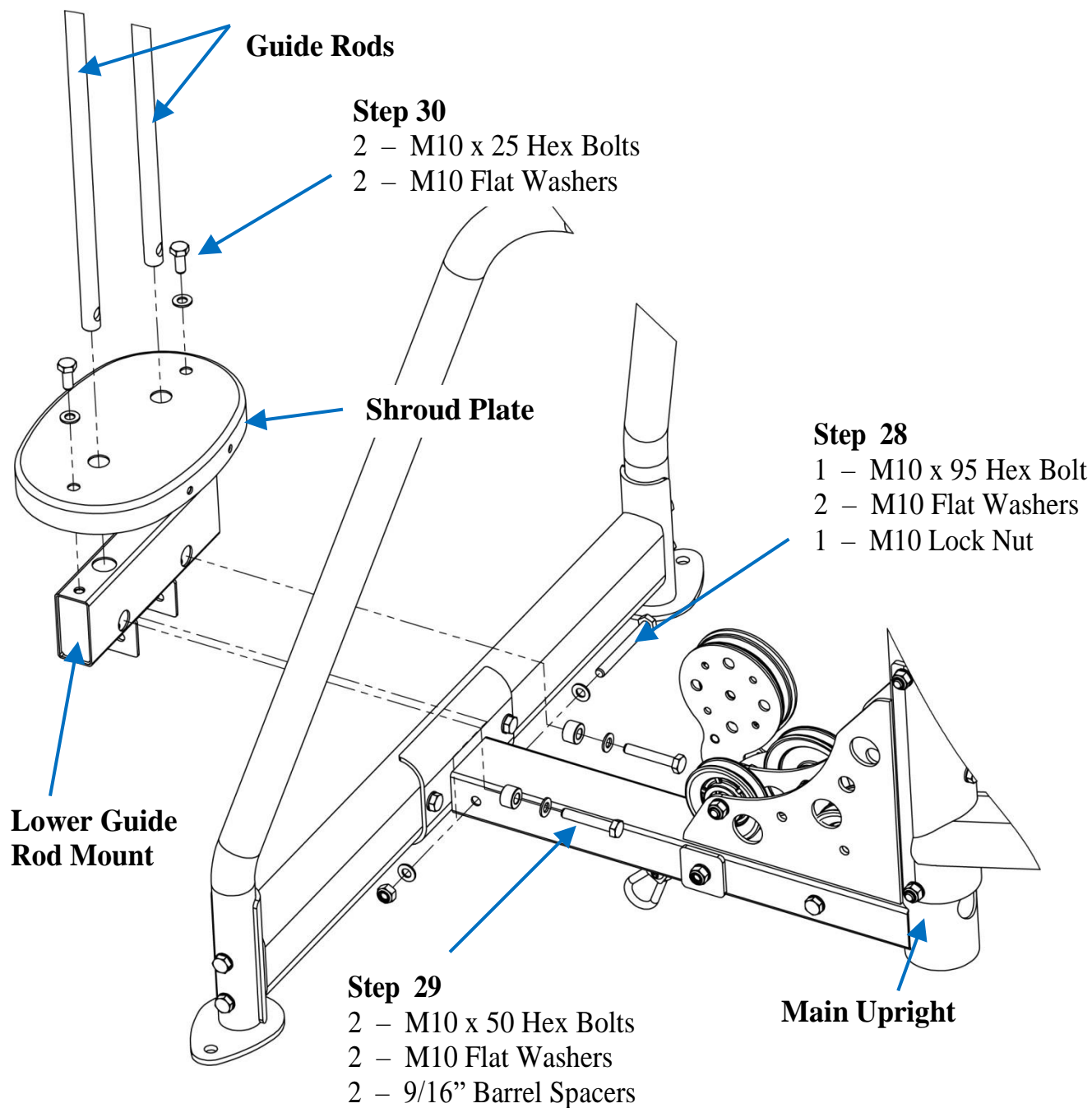

**Step 28:** Attach the Lower Guide Rod Mount to the base of the Main Upright.

**Step 29:** Slide the Guide Rods through the large holes on the Shroud Plate (make sure open side is down and 2 holes are facing forward) and the Lower Guide Rod Mount. Then attach the barrel spacers and hardware indicated to the Guide Rods and Lower Guide Rod Mount.

**Step 30:** Attach the Shroud Plate to the Lower Guide Rod Mount. **Tighten Steps 28, 29 & 30 Now!**

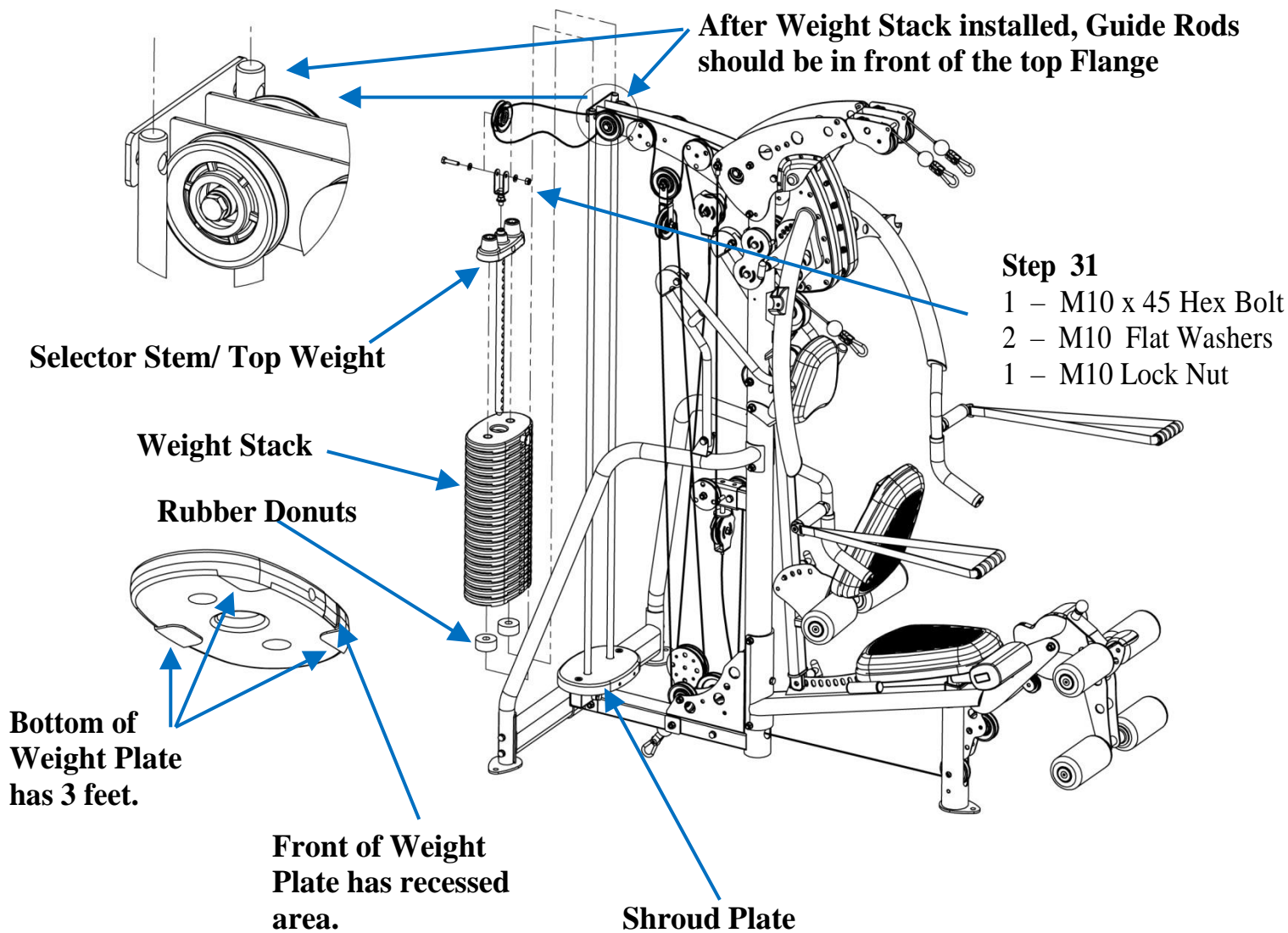

**Step 31:** Tilt Guide Rods back to install Rubber Donuts, 20 Weight Plates (Weight Stack), Top Weight/Selector Stem (**In That Order**). See Note below.

Make sure the U Bracket at the top of the Selector Stem is fully inserted in the stem, turned sideways as shown and **tighten the jam nut under the U Bracket against the Selector Stem.**

Attach pulley (with cable from upper pulleys wrapped around it) to the U bracket on top of the Selector Stem. Make sure cable is not twisted. **Tighten Now!!**

**Note:** If Guide Rods don't tilt back far enough to slide on weights, loosen bolt under Lower Guide Rod Mount slightly. **Tighten again after weights are on.**

### **INSTALL WEIGHT STICKERS NOW**

Front of weight plate has recessed area for weight plate number.

Slide Weight Pin into one of the weights after installed.

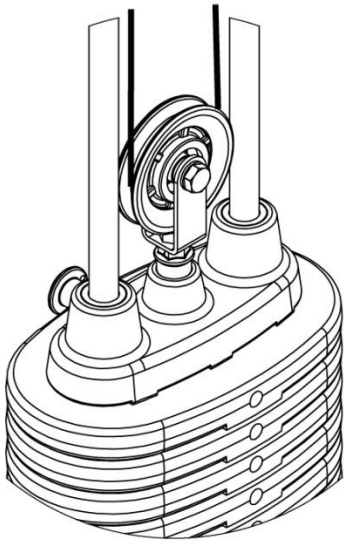

### Step 32

- 2 – M10 x 45 Hex Bolts
- 4 – M10 Flat Washers
- 2 – M10 Lock Nuts

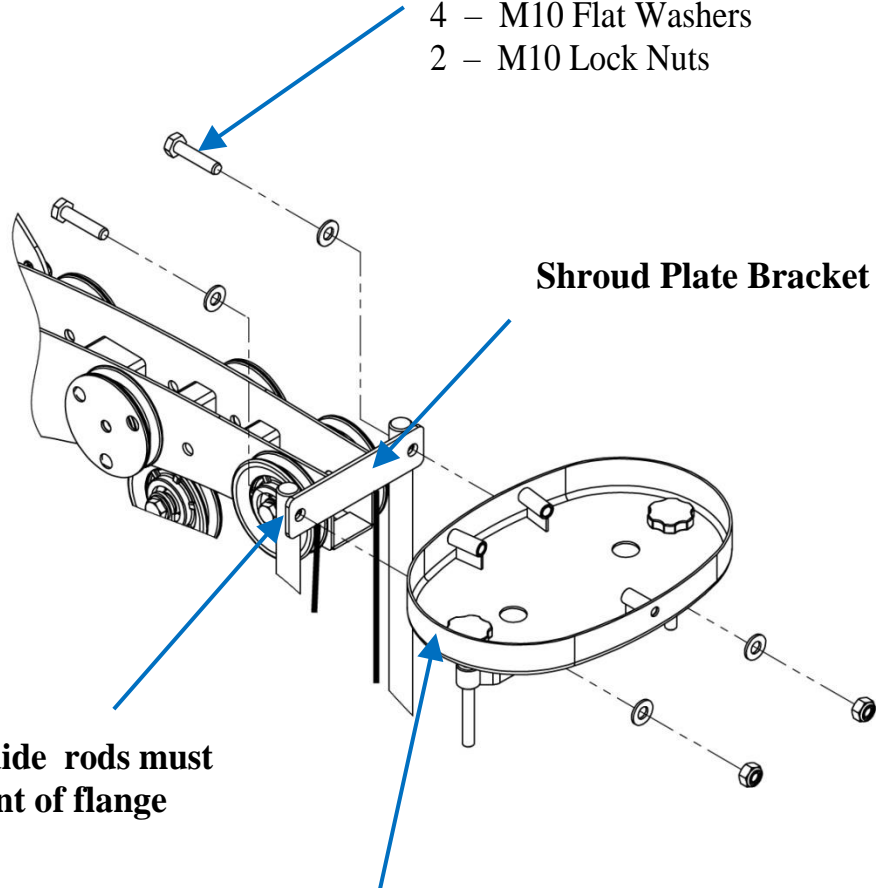

**Shroud Plate Bracket**

**Note: Guide rods must be in front of flange**

**Shroud Plate Assembly**

**Step 32:** Attach the Guide Rods to the **front** of the Shroud Plate Bracket and the Shroud Plate Assembly (open side up and 2 holes facing forward). **Tighten Now!**

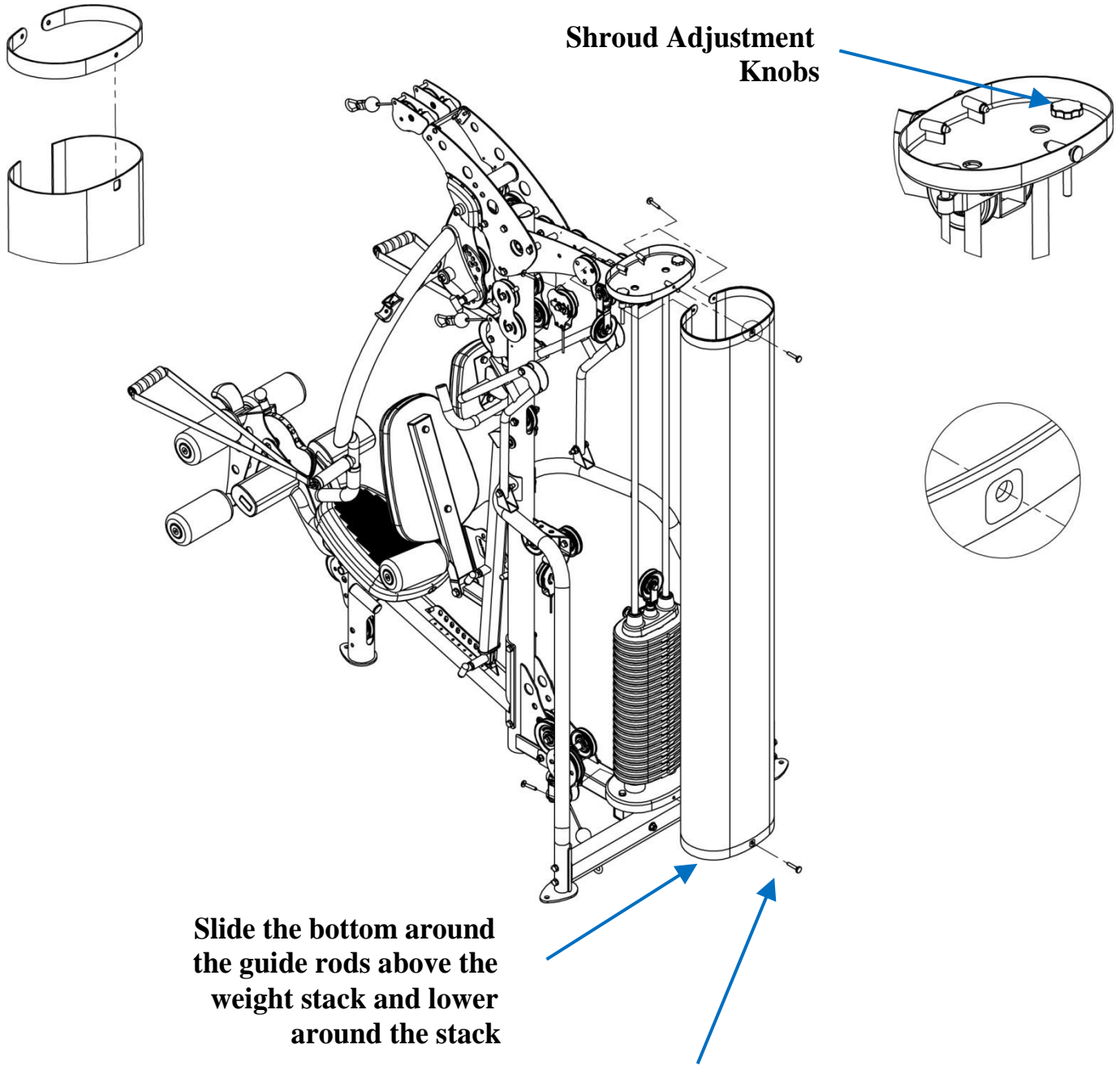

**Slide the bottom around the guide rods above the weight stack and lower around the stack**

**Step 33**  
6 – Shroud Plate Connector Pin

**Step 33:** Slide the C shaped Shroud Bracket into the pocket at one end of Shroud. (**Pocket seam should face the inside**). Work the shroud around the bracket until the opening in the back of the shroud lines up with the hole on the back of the bracket. Repeat this on the other end of the shroud.

Now position this shroud assembly around the upper and lower Shroud Mount Plates by working around the guide rods and stack. Align the holes at the top and bottom brackets with the holes in the plates and insert the Shroud Plate Connector Pin in each hole (3 on top and 3 on bottom).

Next, stretch the shroud tight by using the Shroud Adjustment Knobs at the top. Turn counter clockwise working between the 2 knobs to adjust each side up a little at a time.

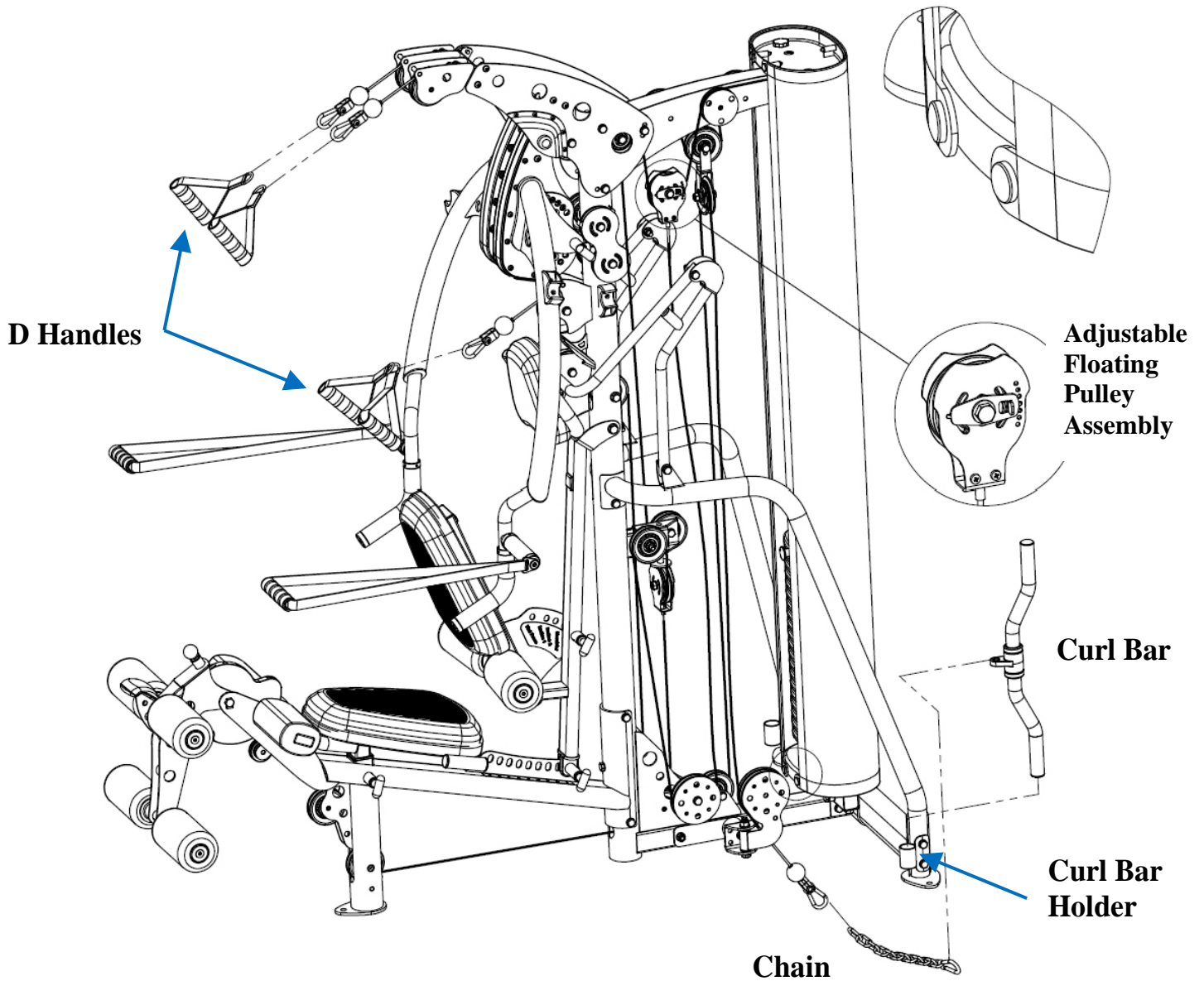

**Step 34:** Eliminate the cable slack at the Upper Floating Pulley Assembly indicated above by loosening the bolt and moving the pulley up or down with the selector plate. **Tighten the bolt when finished.**

Now attach the D Handle straps, Chain, and Curl Bar to the cable ends with Spring Links as shown. Curl Bar should be stored in the round Holder.

**Tighten all Top Beam Plate Bolts Now. Attach Dome Caps from Step 10 to Press Arm Shaft.**

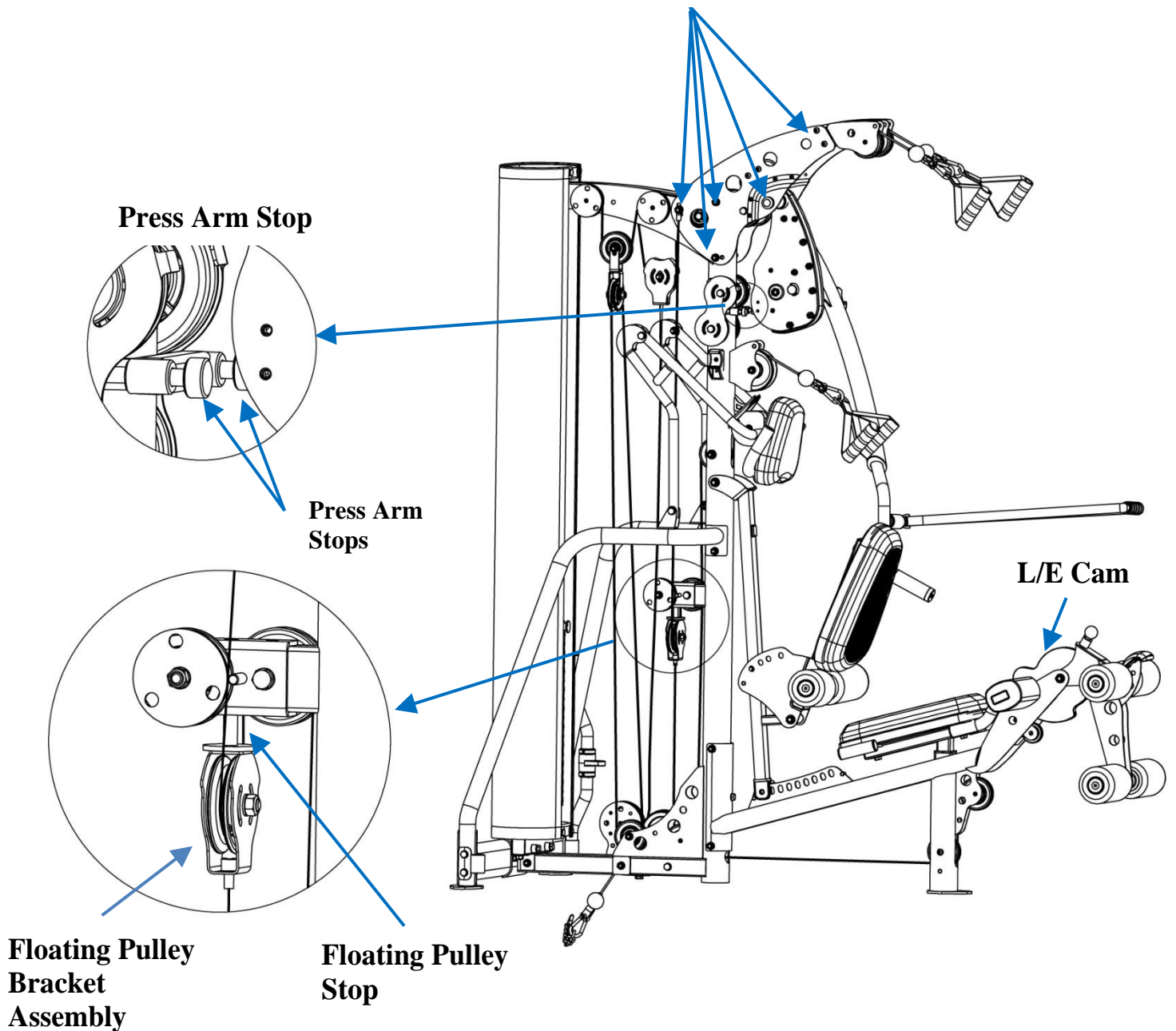

**Step 35: Important**, Make sure Top Beam Plates are level at the top, front, and Press Arms are centered on the Seat. Next, **tighten all bolts on the Top Beam Plates and Press Arm Shaft** from Steps 6, 8, 9, 10, and 17. Attach Dome Caps from Step 10 to Press Arm Shaft.

**NOTE:** At this point it is necessary to seat the cables. Start by verifying that the cables are centered in the grooves of all pulleys. Next, select a weight you can comfortably handle on the bench press. Perform a seated bench press and hold the first repetition at arms length. Now, lightly bounce the weight up and down for about 5 seconds. This will seat the cables into the pulleys and prepare the gym for Step 36.

**Step 36:** Adjust the Stop at the Single Floating Pulley to remove slack from the cable attached to the Leg Extension. Set the Cam on the Leg Extension so that the cable opening is in line with the 2 small pulleys before adjusting. The stop should be down against the top of the Floating Pulley Bracket. **Tighten the Jam Nut when finished.**

The press arm starting position may be adjusted by screwing the Press Arm Stop in or out. Lock using the Jam Nut when finished.

# DECAL REFERENCE

NOTICE				
<i>This INSPIRE product is not intended for commercial use.</i>				
IN HOME MAINTENANCE	Weekly	Monthly	Yearly	Years
Inspect; Links, Pull Pins, Snap Locks, Swivels, Weight Stack Pins	X			
Clean; Upholstery	X			
Inspect; Cables and their fittings	X			
Inspect taughtness of all shrouds	X			
Inspect; Accessory Bars and Handles		X		
Inspect; All Decals		X		
Inspect; All nuts and Bolts Tighten if Needed.		X		
Inspect; Anti-Skid Surfaces		X		
Clean & Lubricate; Guide Rods with a Teflon(PTFE) based lubricant (Superlube)		X		
Lubricate; Seat Sleeves and all plastic slides		X		
Clean & Wax; All Glossy Finishes			X	
Replace; Cables, Belts and Connectin Parts.				X



**INSPIRE™**  
 BY HEALTH IN MOTION LLC  
 877-738-1729  
[www.inspirefitness.net](http://www.inspirefitness.net)  
 Serial # 4-05-05-00001

This product covered by one or more of the following US Patents and others pending: 5,330,405; 5,944,641; 5,961,427; 7,645,217; 7,722,513; 7,837,600; 7,905,818; 8,096,929.

**⚠ WARNING**

USE ONLY GENUINE INSPIRE REPLACEMENT PARTS. FAILURE TO DO SO WILL VOID WARRANTY AND COULD RESULT IN SERIOUS INJURY. THERE IS A RISK ASSUMED BY INDIVIDUALS WHO USE THIS TYPE OF EQUIPMENT. TO MINIMIZE THE RISK, ALWAYS FOLLOW THESE RULES.

1. READ & UNDERSTAND ALL ENCLOSED INSTRUCTIONS BEFORE USING THIS EQUIPMENT.
2. INSPECT EQUIPMENT BEFORE EACH USE. Replace parts that show any wear or damage. If in doubt about a certain part, DO NOT use the equipment until the part is replaced. Failure to replace worn or damaged parts may result in injury.
3. FOLLOW MAINTENANCE SCHEDULE on the "NOTICE" sticker
4. CONSULT YOUR PHYSICIAN BEFORE STARTING ANY EXERCISE PROGRAM. Warm up properly before exercising. Stop exercising if you feel faint or dizzy.
5. TO PREVENT THE POSSIBILITY OF SERIOUS INJURY, KEEP CLEAR OF ALL MOVING PARTS. DO NOT ATTEMPT TO FREE ANY JAMMED PART BY YOURSELF. Obtain assistance in order to avoid possible injury.
6. Take your time and do not rush exercise. Practice proper breathing, NEVER hold your breath.
7. CHILDREN SHOULD NOT BE ALLOWED TO USE THIS EQUIPMENT. To avoid possible injury, children should be kept at a safe distance when this equipment is in use. Teenagers should not use this equipment without adult supervision.
8. CALL YOUR AUTHORIZED INSPIRE DISTRIBUTOR if you have any questions on the proper use or maintenance of this equipment.



## DECAL REFERENCE

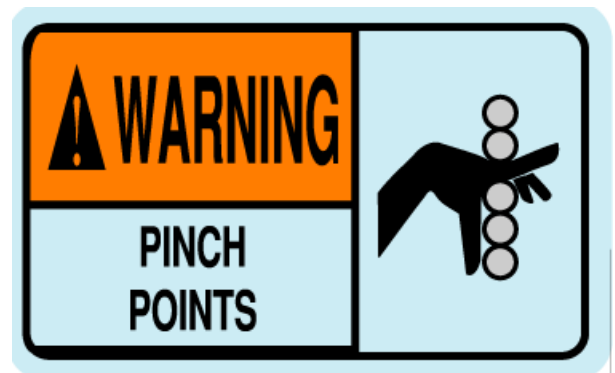
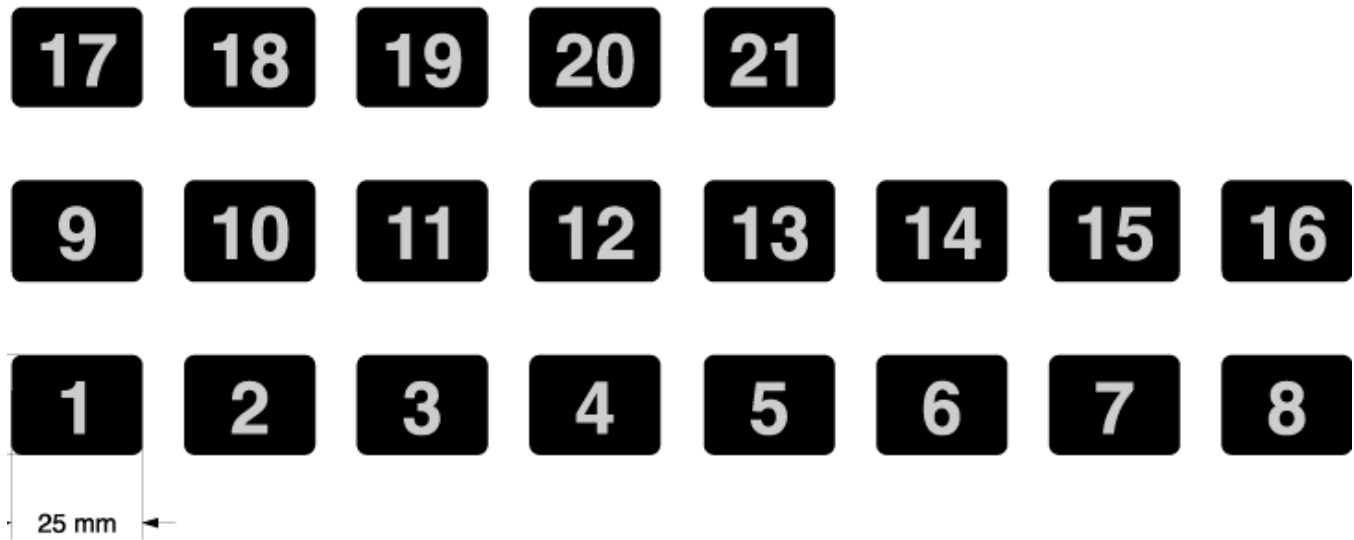

# DECAL PLACEMENT

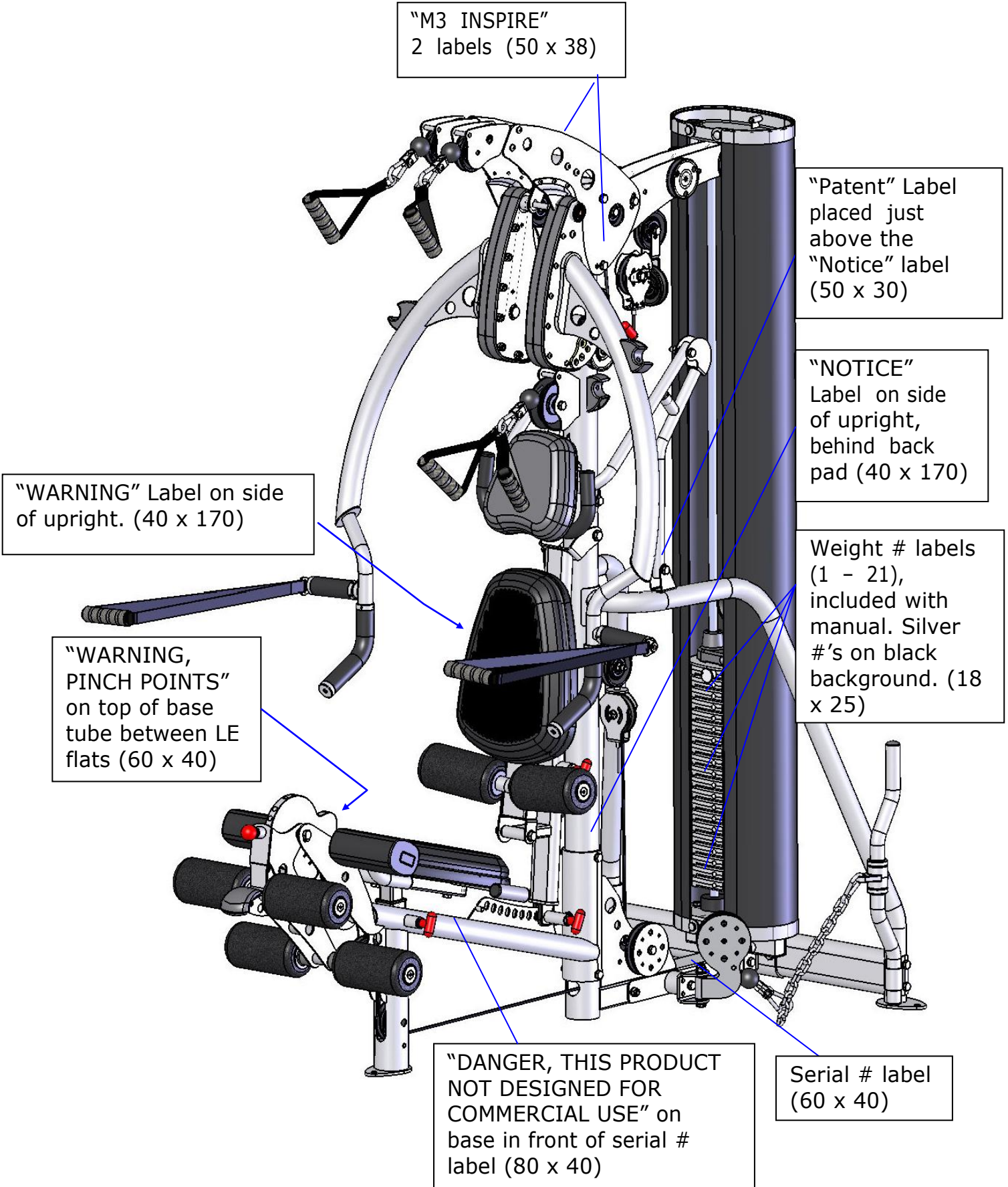

## **ACCESSORIES**

- Exercise Wall Chart
- Revolving Lat Bar
- Revolving EZ Curl Bar
- Ankle Strap
- Abdominal Strap Handle

## **HOME GYM OPTIONS**

- Colored Orthopedic Pads
- Colored Shroud
- Leg Press
- Ab Crunch Bar

## **Training Tips**

*CONSULT A PHYSICIAN BEFORE STARTING ANY EXERCISE PROGRAM*

1. **Always warm up** before you start weight training. This helps get your muscles warm and prevents injury. You can warm up with light cardio or by doing a light set of each exercise before going to heavier weights.
2. **Control the weight.** Always work with a weight that you can handle through a full range of motion. Slow and steady movements are recommended.
3. **Breathe.** Don't hold your breath during your set. Holding your breath builds internal pressure which increases your chance for broken blood vessels, as well as a hernia.
4. **Sit up straight.** Pay attention to your posture and keep everything straight. Engage your abs in every movement to keep balanced and protect your spine.

## **GENERAL MAINTENANCE INFORMATION**

**Warning: DO NOT place styrofoam or printed materials on the orthopedic seat pads. Over time, these may stick to the pads and mar the surface.**

**Do not leave items sitting on the orthopedic seat pads, these pads have a special density that takes shape to objects and small objects will leave imprints in the surface that may take time to come out.**

- Periodically inspect the cables for splitting, cracking or fraying. Also, watch for bulging or flat areas in the cable.
- Immediately replace cables at the first signs of damage or wear. Never use equipment with damaged or worn cables.
- Cables naturally stretch over time, so check cable slack periodically and adjust cable tension as needed. See Step 34 and Step 36 to adjust cable tension.
- Regularly inspect product for loose hardware.
- Do not use or store equipment outdoors.
- Inspect snap links, swivels, handles and weight stack pin for wear or damage. If wear or damage exists, replace immediately.
- Locate and familiarize yourself with all warning decals on the home gym.
- Replace damaged or worn upholstery immediately.
- Periodically wipe down guide rods with a dry cloth and re-apply a thin coat of a teflon-based lubricant.

# MAINTENANCE SCHEDULE

ROUTINE	HOME MAINTENANCE	ENTRY DATE									
Inspect: Links, Pull Pins, Spring Clips, Swivels, Weight Stack Pins	WEEKLY										
Clean: Upholstery	WEEKLY										
Inspect: Cables and their Fittings	WEEKLY										
Inspect: Tautness of all Shrouds	WEEKLY										
Inspect: Accessory Bars and Handles	3 MONTHS										
Inspect: All Decals	3 MONTHS										
Inspect: All Nuts and Bolts. Tighten if Needed	3 MONTHS										
Inspect: Anti-Skid surfaces	3 MONTHS										
Clean and Lubricate: Guide Rods with a Teflon based lubricant	3 MONTHS										
Lubricate: Seat Sleeves and all Plastic Slides	3 MONTHS										
Clean and Wax: All Glossy Finishes	YEARLY										
Replace: Cables, Belts and Connecting Parts	2 YEARS										

# INSPIRE

## Warranty.

This Warranty applies to Inspire Strength products manufactured or distributed by Health In Motion LLC.

### CONSUMER USE:

#### LIMITED LIFETIME FRAME:

Includes Frame and Welds

#### LIMITED LIFETIME PARTS:

Includes Upholstery, Hardware, etc.

#### LIMITED LIFETIME MOVING PARTS:

Includes Pulleys, Cables, etc.

### LIGHT-COMMERCIAL USE:

#### LIMITED LIFETIME FRAME:

Includes Frame and Welds

#### 10 YEAR PARTS:

Includes Upholstery, Hardware, etc.

#### 10 YEAR MOVING PARTS:

Includes Pulleys, Cables, etc.

### PLEASE NOTE THAT NOT ALL INSPIRE PRODUCTS ARE MADE FOR LIGHT-COMMERCIAL USE

Refer to your Owner's Manual or consult with your fitness product dealer to establish if a Product is made for light-commercial use or not. Using a non-commercial product in a commercial setting can result in serious injury or death!

Health In Motion warrants that the Product you have purchased for light-commercial, personal, family or household use from Health In Motion LLC or from an authorized Health In Motion reseller is free from defects in materials or workmanship under normal use during the warranty period. Your sales receipt, showing the date of purchase of the Product, is your proof of the date of purchase. This warranty extends only to you, the original purchaser. It is not transferable to anyone who subsequently purchases the Product from you. It excludes expendable parts such as paint and finish. This Warranty becomes VALID ONLY if the Product is assembled / installed according to the instructions / directions included with the Product.

### Replacement and repair of parts.

During the warranty period Health In Motion will, at no additional charge, repair or replace the Product if it becomes defective, malfunctions, or otherwise fails to conform with this Warranty under normal light-commercial, personal, family, or household use. In repairing the product Health In Motion may replace defective parts with, at the option of Health In Motion, serviceable used parts that are equivalent to new parts in performance, or new parts. All exchanged parts and Products replaced under this warranty will become the property of Health In Motion. Health In Motion reserves the right to change manufacturers and or specification of any part to cover any existing warranty.

### Service procedures.

To obtain warranty parts, you must return the parts to Health In Motion or an authorized Health In Motion retailer in its original container (or equivalent). You must pre-pay any shipping charges, taxes, or any other charges associated with transportation of the Product. In addition, you are responsible for insuring any Product shipped or returned. You assume the risk of loss during shipment. You must present Health In Motion with proof-of-purchase documents (including the date of purchase, Model, and Serial Number). Any evidence of alteration, erasing or forgery of proof-of-purchase documents will be cause to void this Warranty. Register your warranty online visit [www.inspirefitness.net](http://www.inspirefitness.net)

### Conditions and Exceptions.

This Warranty does not extend to any Product not purchased from Health In Motion LLC or from an authorized Health In Motion reseller. This Warranty does not extend to any Product that has been damaged or rendered defective; (a) as a result of accident, misuse, or abuse; (b) by the use of parts not manufactured or sold by Health In Motion; (c) by modification of the Product; (d) as a result of service by anyone other than Health In Motion, or an authorized Health In Motion warranty service provider; (e) product that has not been properly maintained (follow maintenance schedule found on product). Should any product submitted for Warranty service be found to be ineligible, an estimate of repair cost will be furnished and the repair will be made if requested by you upon Health In Motion receipt of payment or acceptable arrangement of payment.

### Disclaimer

EXCEPT AS EXPRESSLY SET FORTH IN THIS WARRANTY HEALTH IN MOTION MAKES NO OTHER WARRANTIES; EXPRESSED OR IMPLIED INCLUDING ANY IMPLIED WARRANTIES OF MERCHANTABILITY AND FITNESS FOR A PARTICULAR PURPOSE. HEALTH IN MOTION EXPRESSLY DISCLAIMS ALL WARRANTIES NOT STATED IN THIS WARRANTY. ANY IMPLIED WARRANTIES THAT MAY BE IMPOSED BY LAW ARE LIMITED TO THE TERMS OF THIS WARRANTY. NEITHER HEALTH IN MOTION NOR ANY OF ITS AFFILIATES SHALL BE RESPONSIBLE FOR INCIDENTAL OR CONSEQUENTIAL DAMAGES. HEALTH IN MOTION IS NOT RESPONSIBLE FOR THE REPAIR OR REPLACEMENT OF ANY PARTS THAT HEALTH IN MOTION DETERMINES HAVE BEEN SUBJECTED AFTER THE DATE OF MANUFACTURE TO ALTERATION, NEGLIGENCE, ABUSE, MISUSE, NORMAL WEAR & TEAR, ACCIDENT, DAMAGE DURING TRANSIT OR INSTALLATION, FIRE, FLOOD, OR ANY ACT OF GOD. SOME STATES DO NOT ALLOW LIMITATIONS ON HOW LONG AN IMPLIED WARRANTY LASTS OR THE EXCLUSION OR LIMITATION OF INCIDENTAL OR CONSEQUENTIAL DAMAGES, SO THE ABOVE LIMITATIONS OR EXCLUSION MAY NOT APPLY TO YOU. This Warranty gives you specific legal rights and you may also have other rights that may vary from state to state. This is the only express warranty applicable to Health In Motion's "Inspire" branded strength products. Health In Motion neither assumes nor authorizes anyone to assume for it any other express warranty.