

# NordicTrack®

## EXP 10i

Model No. NTL15421-INT.4

Serial No. \_\_\_\_\_

Write the serial number in the space above for reference.

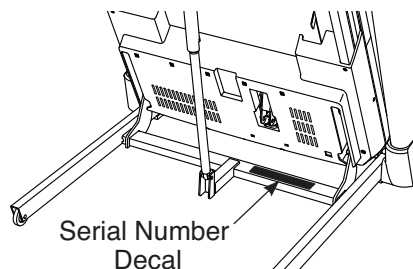

## USER'S MANUAL

### MEMBER CARE

#### UNITED KINGDOM

Call: 0330 123 1045

From Ireland: 053 92 36102

Website: [iconsupport.eu](http://iconsupport.eu)

E-mail: [csuk@iconeurope.com](mailto:csuk@iconeurope.com)

**Write:**

ICON Health & Fitness, Ltd.

Unit 4, Westgate Court

Silkwood Park

OSSETT

WF5 9TT

UNITED KINGDOM

#### AUSTRALIA

Call: 1800 993 770

E-mail: [australiacc@iconfitness.com](mailto:australiacc@iconfitness.com)

**Write:**

iFIT Inc.

PO Box 635

WINSTON HILLS NSW 2153

AUSTRALIA

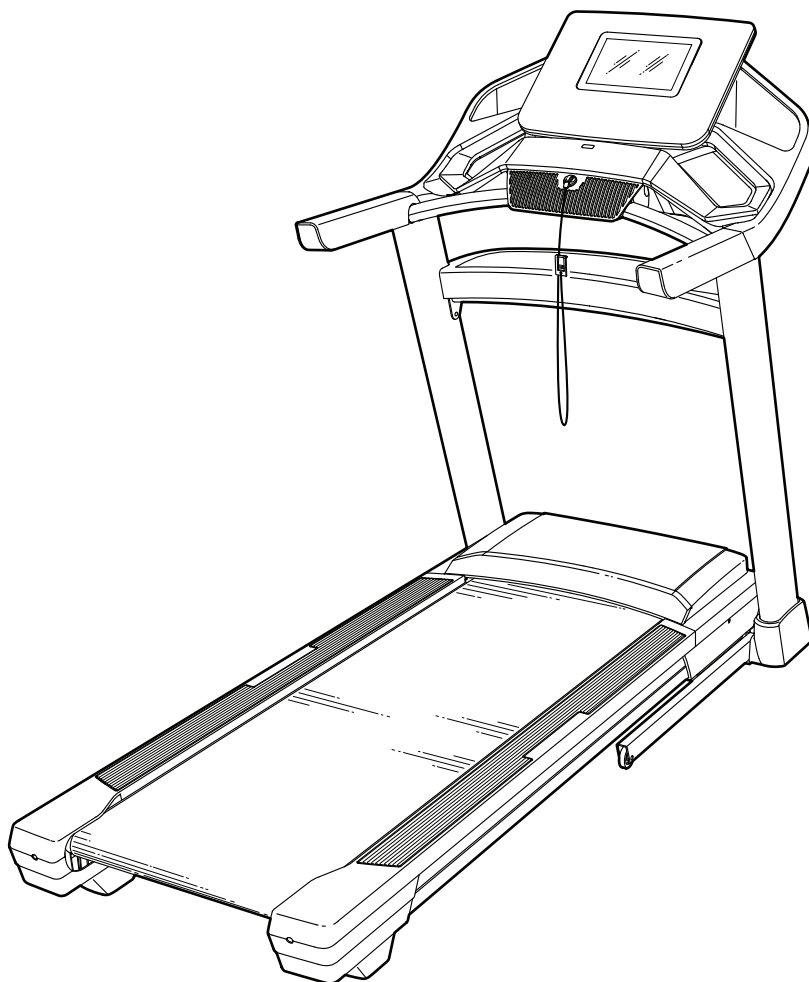

### ⚠ CAUTION

Read all precautions and instructions in this manual before using this equipment. Keep this manual for future reference.

# TABLE OF CONTENTS

WARNING DECAL PLACEMENT ..... 2

IMPORTANT PRECAUTIONS ..... 3

BEFORE YOU BEGIN ..... 5

PART IDENTIFICATION CHART ..... 6

ASSEMBLY ..... 7

HOW TO USE THE TREADMILL ..... 17

HOW TO FOLD AND MOVE THE TREADMILL ..... 30

MAINTENANCE AND TROUBLESHOOTING ..... 31

EXERCISE GUIDELINES ..... 34

PART LIST ..... 38

EXPLODED DRAWING ..... 40

ORDERING REPLACEMENT PARTS ..... Back Cover

RECYCLING INFORMATION ..... Back Cover

## WARNING DECAL PLACEMENT

This drawing shows the locations of the warning decals. **If a decal is missing or illegible, call the telephone number on the front cover of this manual and request a free replacement decal. Apply the decal in the location shown.** Note: The decals may not be shown at actual size.

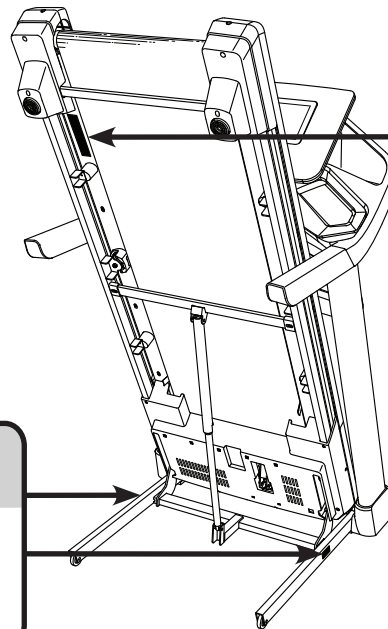

**▲WARNING:**  
Protect yourself and others from risk of serious injury. Read the user's manual, and:

- Stand only on the side rails when starting or stopping treadmill.
- Change speed in small increments.
- Hold handrails to prevent falling, and always wear the safety clip while operating the treadmill.
- Stop if you feel faint, dizzy, or short of breath.
- Fully engage the storage latch before the treadmill is moved or stored.
- Incline should be set to zero before folding the treadmill into a storage position.

• Never allow children on or around the treadmill.

• Remove the safety key when treadmill is not in use.

• Keep clothing, fingers, and hair away from moving parts.

• Never try to adjust or fix the belt while it is moving.

• Always wear athletic shoes while operating the treadmill.

NORDICTRACK and IFIT are registered trademarks of iFIT Inc. Wi-Fi is a registered trademark of Wi-Fi Alliance. WPA and WPA2 are trademarks of Wi-Fi Alliance. The Bluetooth® word mark and logos are registered trademarks of Bluetooth SIG, Inc. and are used under license. Google Play and Google Maps are trademarks of Google LLC.

# IMPORTANT PRECAUTIONS

**⚠️ WARNING:** To reduce the risk of burns, fire, electric shock, or injury to persons, read all important precautions and instructions in this manual and all warnings on your treadmill before using your treadmill. iFIT assumes no responsibility for personal injury or property damage sustained by or through the use of this product.

1. It is the responsibility of the owner to ensure that all users of the treadmill are adequately informed of all warnings and precautions.
2. Keep children under age 16 and pets away from the treadmill at all times.
3. Consult your health care provider before beginning any exercise program. This is especially important for persons over age 35 or persons with pre-existing health problems.
4. Consult your health care provider before beginning or continuing any exercise program during pregnancy. Use the treadmill only as authorized by your health care provider.
5. The treadmill is not intended for use by persons with reduced physical, sensory, or mental capabilities or lack of experience and knowledge unless they have been given supervision or instruction concerning use of the treadmill by someone responsible for their safety.
6. Use the treadmill only as described in this manual.
7. The treadmill is intended for home use only. Do not use the treadmill in any commercial, rental, or institutional setting.
8. Keep the treadmill indoors, away from moisture and dust. Do not put the treadmill in a garage or covered patio, or near water.
9. Place the treadmill on a level surface, with at least 8 ft. (2.4 m) of clearance behind it and 2 ft. (0.6 m) on each side. Do not place the treadmill on any surface that blocks air openings. To protect the floor or carpet from damage, place a mat under the treadmill.
10. Do not operate the treadmill where aerosol products are used or where oxygen is being administered.
11. The treadmill should be used only by persons weighing 300 lbs. (135 kg) or less.
12. Never allow more than one person on the treadmill at a time.
13. Wear appropriate exercise clothes while using the treadmill. Do not wear loose clothes that could become caught in the treadmill. Athletic support clothes are recommended for both men and women. *Always wear athletic shoes. Never use the treadmill with bare feet, wearing only stockings, or in sandals.*
14. When connecting the power cord (see page 17), plug the power cord into an earthed circuit. No other appliance should be on the same circuit. When replacing the fuse in the power cord adapter, insert an ASTA-approved BS1362, 13-amp fuse into the fuse carrier.
15. If an extension cord is needed, use only a 3-conductor, 14-gauge (2 mm<sup>2</sup>) cord that is no longer than 5 ft. (1.5 m).
16. Keep the power cord away from heated surfaces.
17. Never move the walking belt while the power is turned off. Do not operate the treadmill if the power cord or plug is damaged, or if the treadmill is not working properly. (See MAINTENANCE AND TROUBLESHOOTING on page 31 if the treadmill is not working properly.)
18. Read, understand, and test the emergency stop procedure before using the treadmill (see HOW TO TURN ON THE POWER on page 19). Always wear the clip while using the treadmill.
19. Be careful when mounting and dismounting the treadmill. Always stand on the foot rails when starting or stopping the walking belt. Always hold the handrails while using the treadmill.

20. When a person is walking on the treadmill, the noise level of the treadmill will increase.
21. Keep fingers, hair, and clothing away from the moving walking belt.
22. The treadmill is capable of high speeds. Adjust the speed in small increments to avoid sudden jumps in speed.
23. Never leave the treadmill unattended while it is running. Always remove the key, press the power switch into the off position (see the drawing on page 5 for the location of the power switch), and unplug the power cord when the treadmill is not in use.
24. Do not attempt to move the treadmill until it is properly assembled. (See ASSEMBLY on page 7 and HOW TO FOLD AND MOVE THE TREADMILL on page 30.) You must be able to safely lift 45 lbs. (20 kg) to move the treadmill.
25. When folding or moving the treadmill, make sure that the storage latch is holding the frame securely in the storage position. Do not operate the treadmill while it is folded.
26. Do not change the incline of the treadmill by placing objects under the treadmill.
27. Never insert any object into any opening on the treadmill.
28. Inspect and properly tighten all parts each time the treadmill is used. Replace any worn parts immediately. Use only manufacturer-supplied parts.
29. **DANGER:** Always unplug the power cord immediately after use, before cleaning the treadmill, and before performing the maintenance and adjustment procedures described in this manual. Never remove the motor hood unless instructed to do so by an authorized service representative. Servicing other than the procedures in this manual should be performed by an authorized service representative only.
30. Over exercising may result in serious injury or death. If you feel faint, if you become short of breath, or if you experience pain while exercising, stop immediately and cool down.

**SAVE THESE INSTRUCTIONS**

# BEFORE YOU BEGIN

Thank you for selecting the revolutionary NORDICTRACK® EXP 10I treadmill. The EXP 10I treadmill offers an impressive selection of features designed to make your workouts at home more effective and enjoyable. And when you're not exercising, the unique treadmill can be folded up, requiring less than half the floor space of other treadmills.

**For your benefit, read this manual carefully before using the treadmill.** If you have questions after





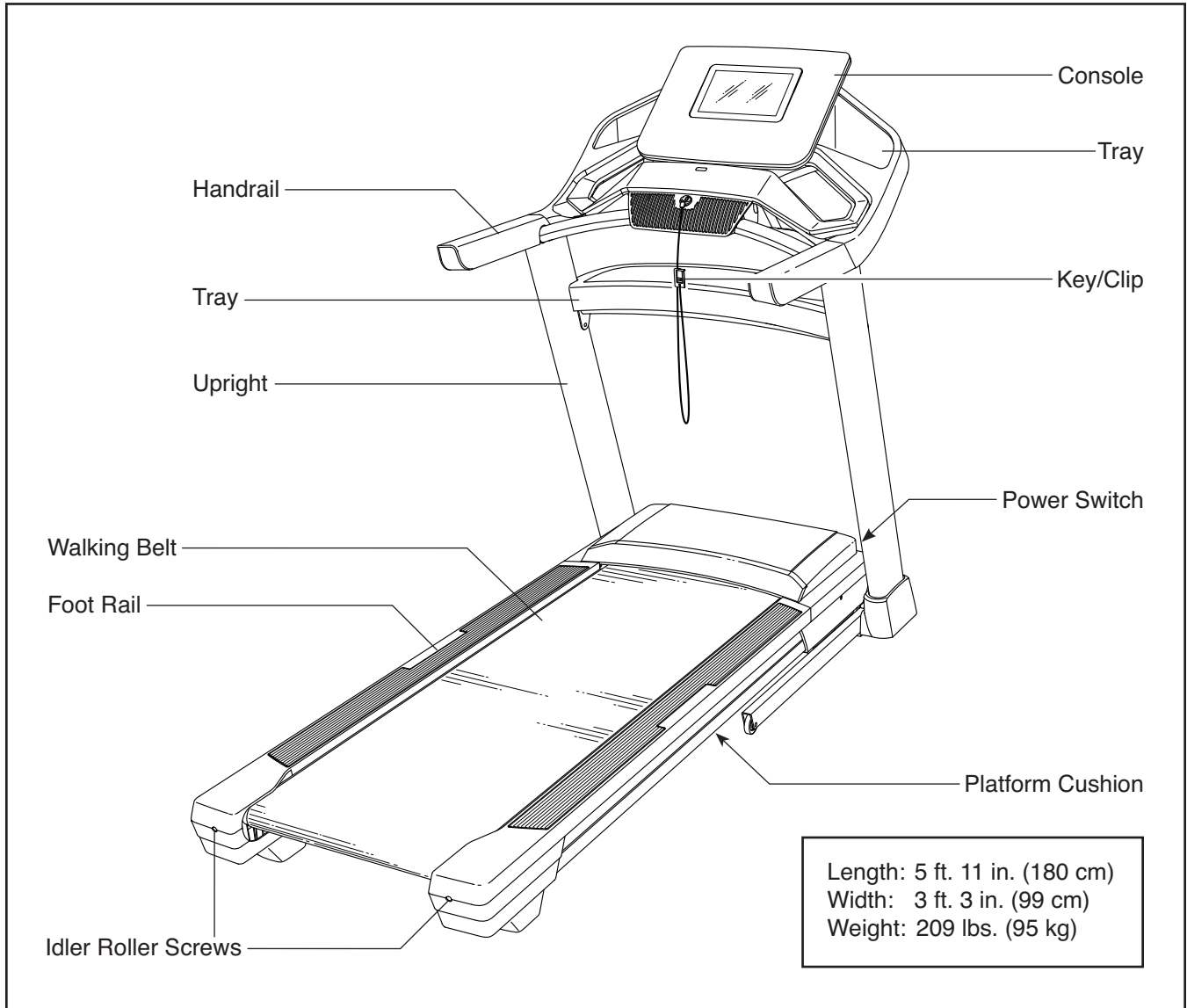

reading this manual, please see the front cover of this manual. To help us assist you, please note the product model number and serial number before contacting us. The model number and the location of the serial number decal are shown on the front cover of this manual.

Before reading further, please review the drawing below and familiarize yourself with the labeled parts.

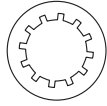
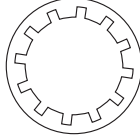

# PART IDENTIFICATION CHART

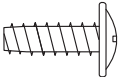
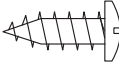
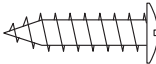
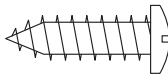
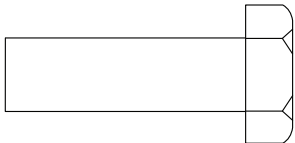
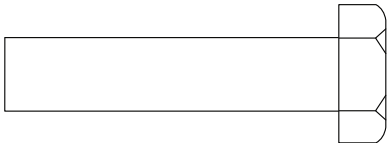
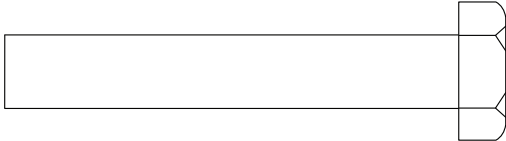
Use the drawings below to identify small parts used for assembly. The number in parentheses below each drawing is the key number of the part, from the PART LIST near the end of this manual. The number following the key number is the quantity used for assembly. **Note: If a part is not in the hardware kit, check to see whether it is preattached. Extra parts may be included.**

				
#10 Star Washer (11)–4	1/4" Star Washer (37)–4	5/16" Star Washer (12)–6	3/8" Star Washer (10)–8	
				
#8 x 3/8" Screw (34)–8	M4 x 13mm Screw (1)–1	#8 x 1/2" Screw (2)–6	#8 x 3/4" Screw (3)–8	#10 x 3/4" Screw (4)–4
				
3/8" x 1 1/4" Screw (7)–2		3/8" x 1 3/4" Screw (6)–2		
				
3/8" x 2 3/8" Screw (5)–4			5/16" x 2 1/2" Screw (8)–4	

# ASSEMBLY

- Assembly requires two persons.
- Place all parts in a cleared area and remove the packing materials. Do not dispose of the packing materials until you finish all assembly steps.
- After shipping, there may be an oily substance on the exterior of the treadmill. This is normal. If there is an oily substance on the treadmill, wipe it off with a soft cloth and a mild, non-abrasive cleaner.
- To identify small parts, see page 6.

- Left parts are marked “L” or “Left” and right parts are marked “R” or “Right.”

- Assembly requires the following tools:

the included hex key



one adjustable wrench



one Phillips screwdriver



To avoid damaging parts, do not use power tools.

1. **To register your product and activate your warranty in the UK**, go to [iconsupport.eu](http://iconsupport.eu). If you do not have internet access, call Member Care (see the front cover of this manual).

**To register your product and activate your warranty in Australia**, email or post the following information to the email address or postal address on the front cover of this manual.

- your receipt (make sure to keep a copy)
- your name, address, and telephone number
- the model number, serial number, and name of your product (see the front cover of this manual)

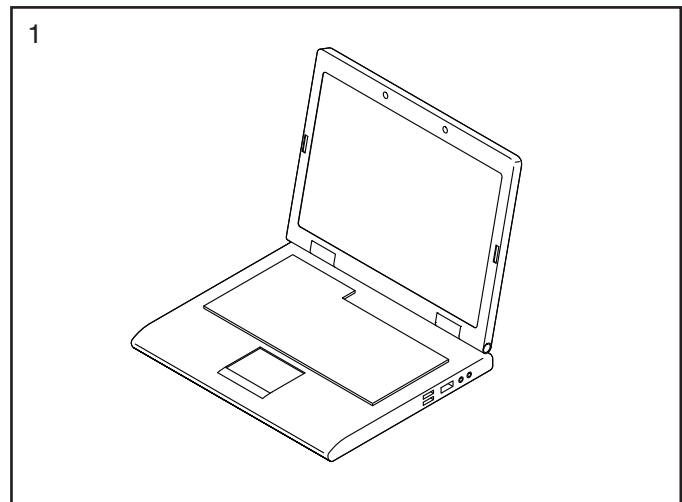

2. **Make sure that the power cord is unplugged.**

Remove the tie securing the Upright Wire (90) to the front of the Base (98).

Next, identify the Right Upright (84). Have a second person hold the Right Upright near the Base (98).

**See the inset drawing.** Tie the wire tie (A) in the Right Upright (84) securely around the end of the Upright Wire (90). Then, insert the Upright Wire into the lower end of the Right Upright, and pull the other end of the wire tie, until the Upright Wire is routed through the Right Upright.

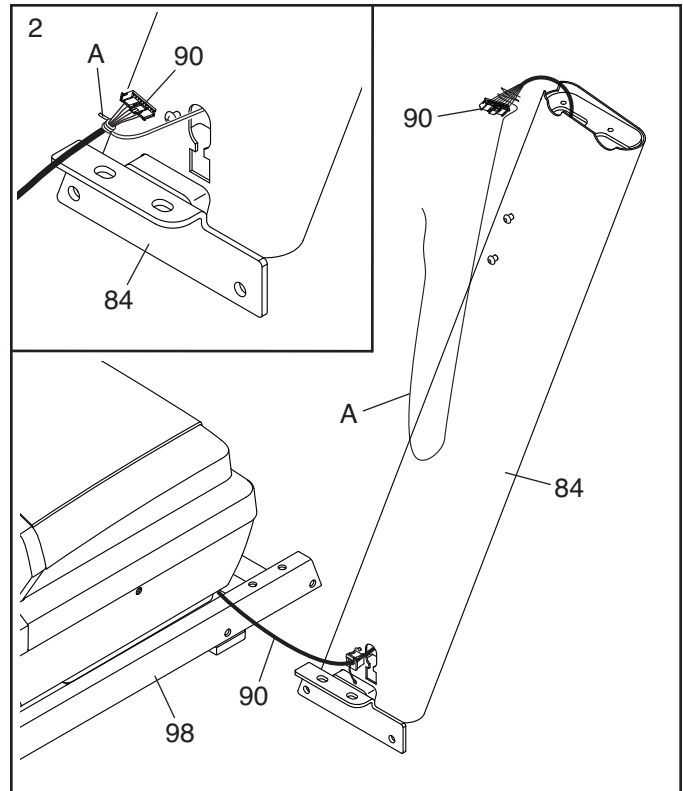

3. Lay the Right Upright (84) near the Base (98). Press the Upright Grommet (91) into the square hole (B) in the Right Upright. **Make sure not to pinch the ground wire (C).**

If there is a screw (D) pre-attached to the Right Upright (84), remove and discard it.

Then, attach the ground wire (C) to the Right Upright (84) with an M4 x 13mm Screw (1).

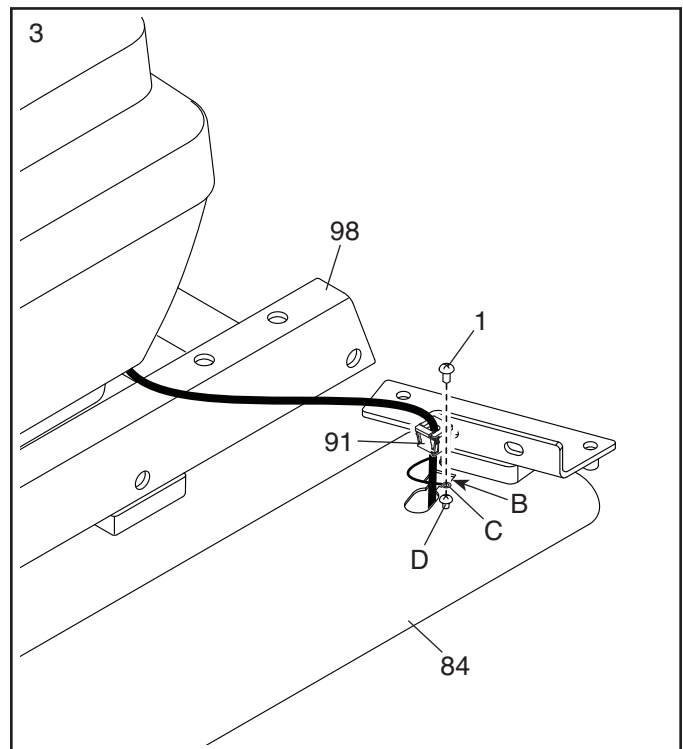



4. Hold the Right Upright (84) against the Base (98). **Make sure not to pinch the Upright Wire (90).**

Attach the Right Upright (84) and a Wheel (99) with two 3/8" x 2 3/8" Screws (5), a 3/8" x 1 1/4" Screw (7), a 3/8" x 1 3/4" Screw (6), and four 3/8" Star Washers (10) as shown; **do not fully tighten the Screws yet.**

**Attach the Left Upright (not shown) and the other Wheel (not shown) in the same way.**

Note: There are no wires on the left side.

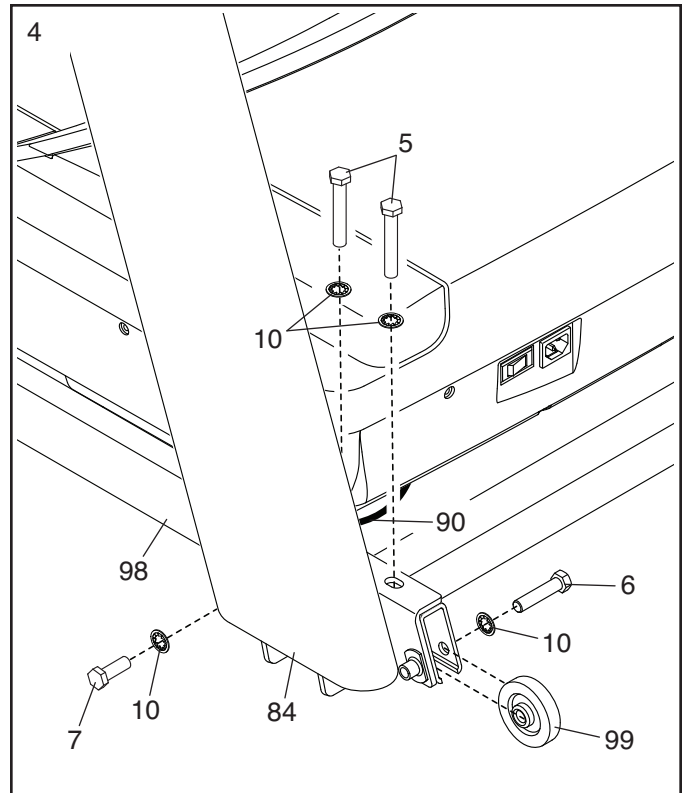

5. **Remove and save the four 5/16" x 3/4" Screws (9).**

Identify the Left and Right Base Covers (94, 93). Slide the Left Base Cover onto the Left Upright (83), and slide the Right Base Cover onto the Right Upright (84); **do not press the Base Covers into place yet.**

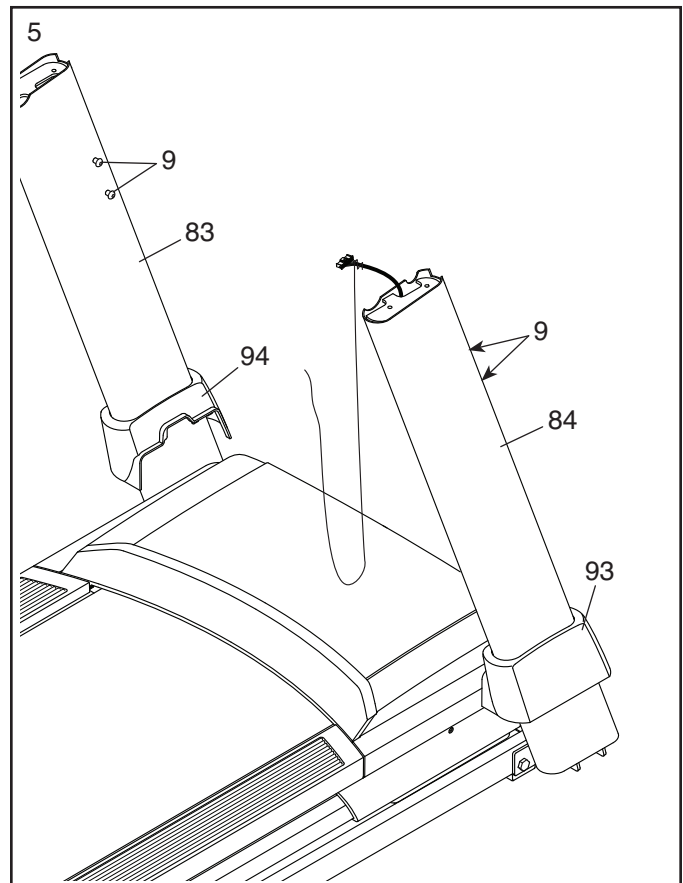

6. Attach the Left and Right Handrails (81, 82) to the Left and Right Uprights (83, 84) with four 5/16" x 2 1/2" Screws (8) and four 5/16" Star Washers (12); **do not fully tighten the Screws yet. Be careful not to pinch the Upright Wire (90) on the right side. Position the Upright Wire in the notch (E) as shown.**

Then, remove and discard the four indicated screws (F).

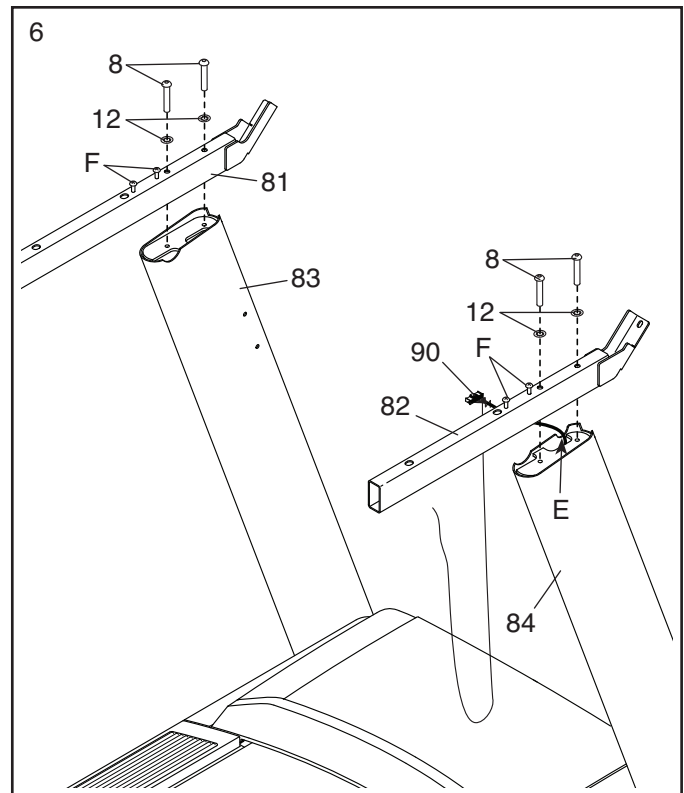

7. Set the console assembly (G) face down on a soft surface to avoid scratching the console assembly. **Remove and save the four 1/4" x 1/2" Screws (21).**

Next, identify the Left and Right Trays (102, 103). Attach the Trays to the console assembly (G) with eight #8 x 3/8" Screws (34); **do not over-tighten the Screws.**

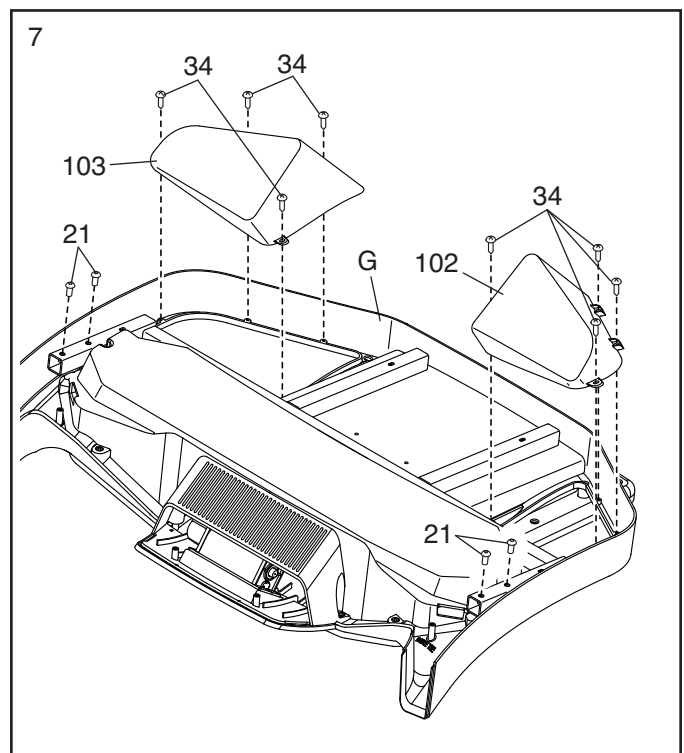

8. **IMPORTANT: To avoid damaging the Crossbar (87), do not use power tools, and do not over-tighten the #10 x 3/4" Screws (4).**

Orient the Crossbar (87) as shown. Attach the Crossbar to the Handrails (81, 82) with four #10 x 3/4" Screws (4) and four #10 Star Washers (11); **start all four Screws, and then tighten them.**

**Then, tighten the four 5/16" x 2 1/2" Screws (8).**

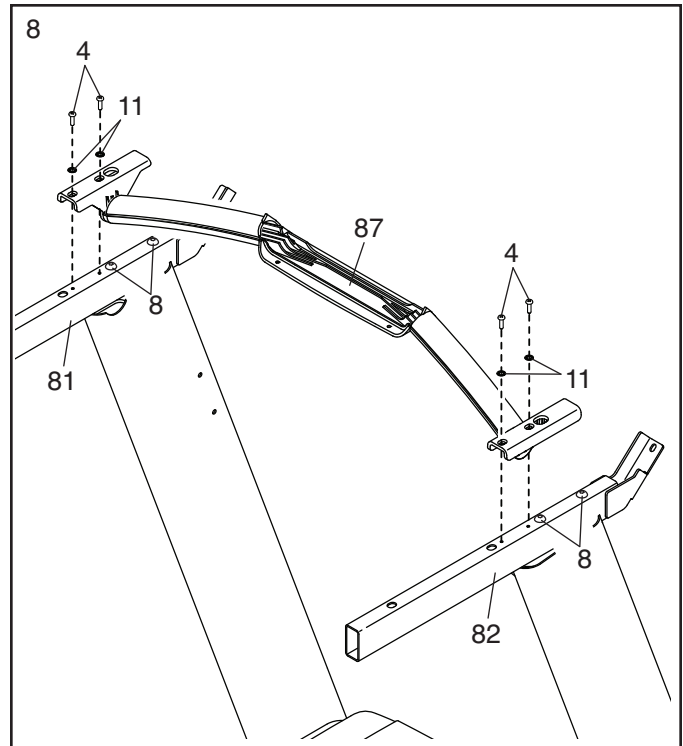

9. With the help of a second person, hold the console assembly (G) near the Right Handrail (82).

Connect the Upright Wire (90) to the console wire (I). **The connectors should slide together easily and snap into place with an audible click. If they do not, turn one connector and try again.**

Then, remove the wire tie (A) from the Upright Wire (90).

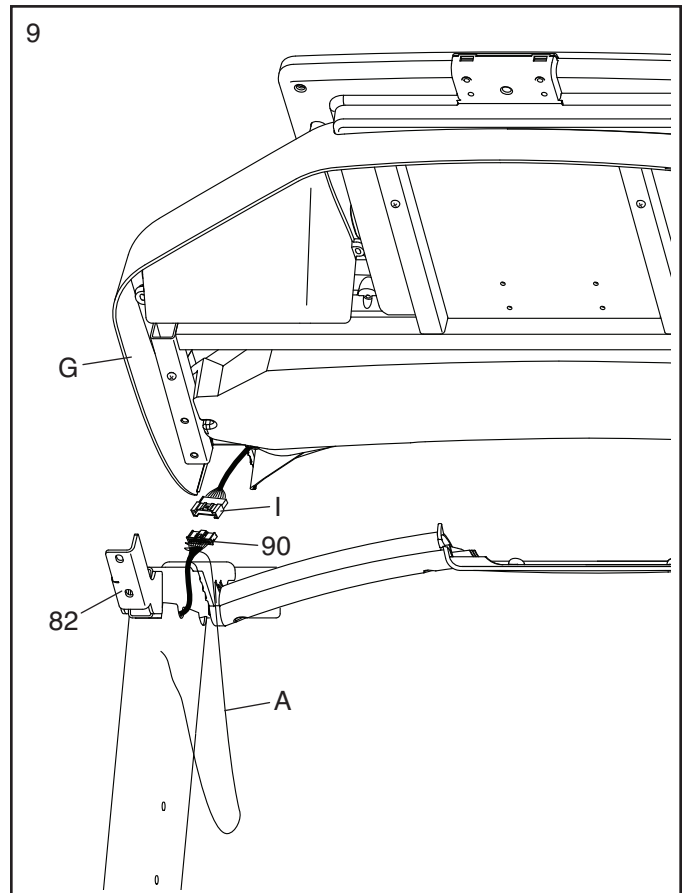

10. Attach the console assembly (G) to the Handrails (81, 82) with four 1/4" x 1/2" Screws (21) that you removed in step 7 and four 1/4" Star Washers (37); **start all four Screws, and then tighten them. Be careful not to pinch the wires (I).**

Insert any excess wire (I) into the top of the Right Upright (84).

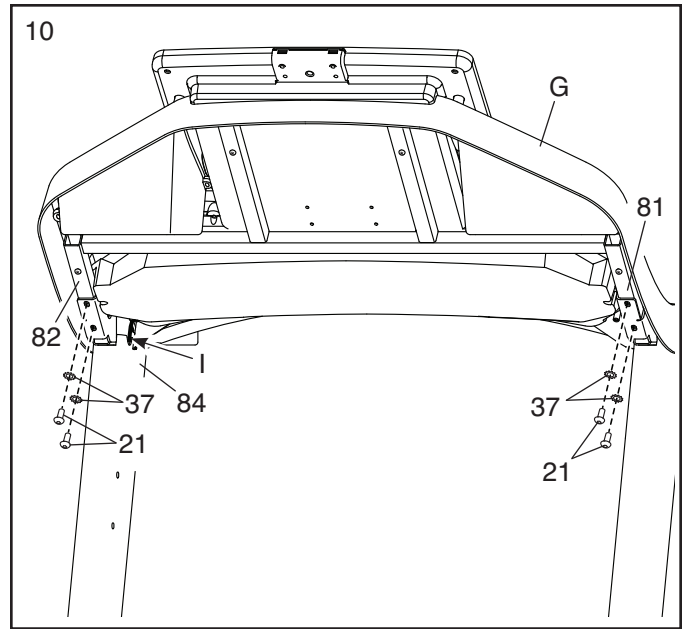

11. Start two #8 x 1/2" Screws (2) into the Crossbar (87), and then tighten them; **do not overtighten the Screws.**

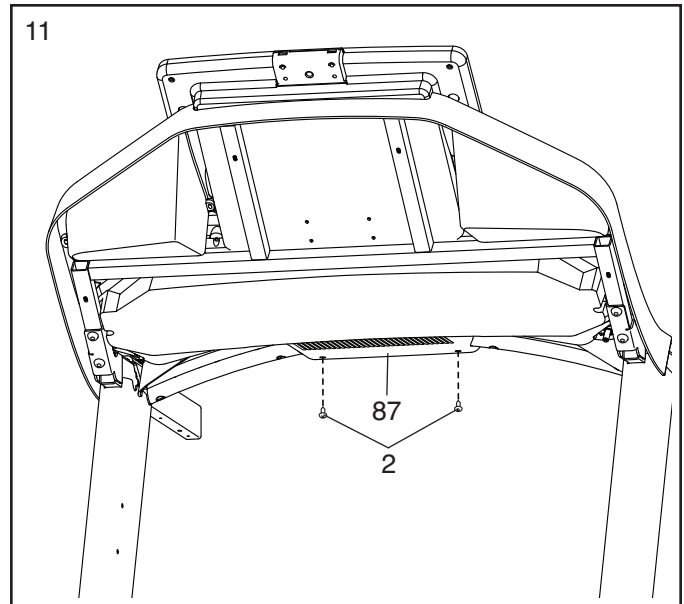

12. Align the Right Top Handrail Cover (78) with the Crossbar (87) and with the holes (J) in the Right Handrail (82). Then, press the Right Top Handrail Cover downward onto the Right Handrail. The front of the Right Top Handrail Cover should flex around the Console Base (101) and snap into place around the Crossbar.

Next, start four #8 x 3/4" Screws (3) into the Right Bottom Handrail Cover (80), the Right Handrail (82), and the Right Top Handrail Cover (78). Then, slide the Right Top and Bottom Handrail Covers forward against the Console Base (101) as shown, and tighten the four Screws.

**Attach the Left Top and Bottom Handrail Covers (77, 79) to the Left Handrail (81) as described above.**

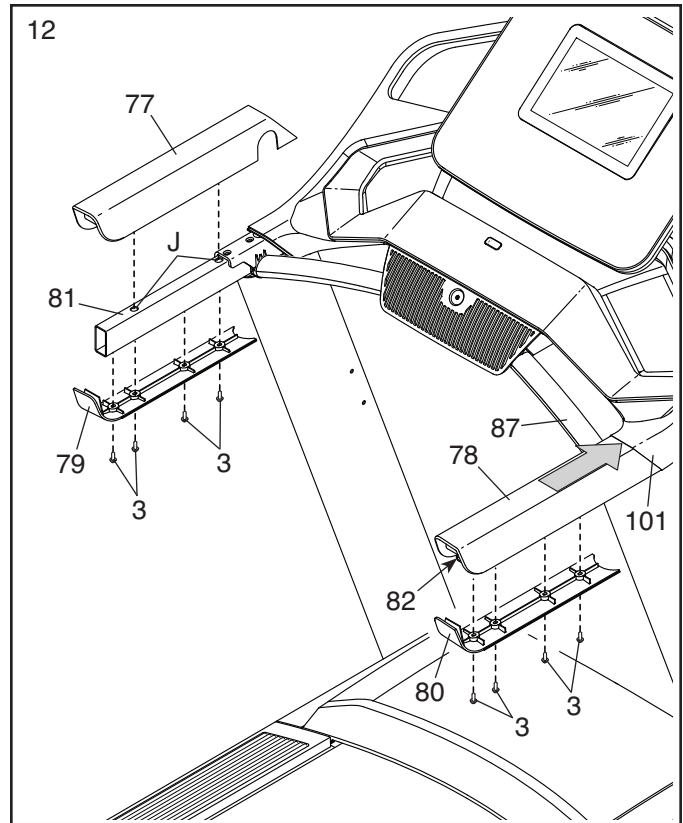

13. Carefully slide the Upright Crossbar (89) between the Right and Left Uprights (84, 83). Attach the Upright Crossbar with the four 5/16" x 3/4" Screws (9) that you removed in step 5; **start all four Screws, and then tighten them.**

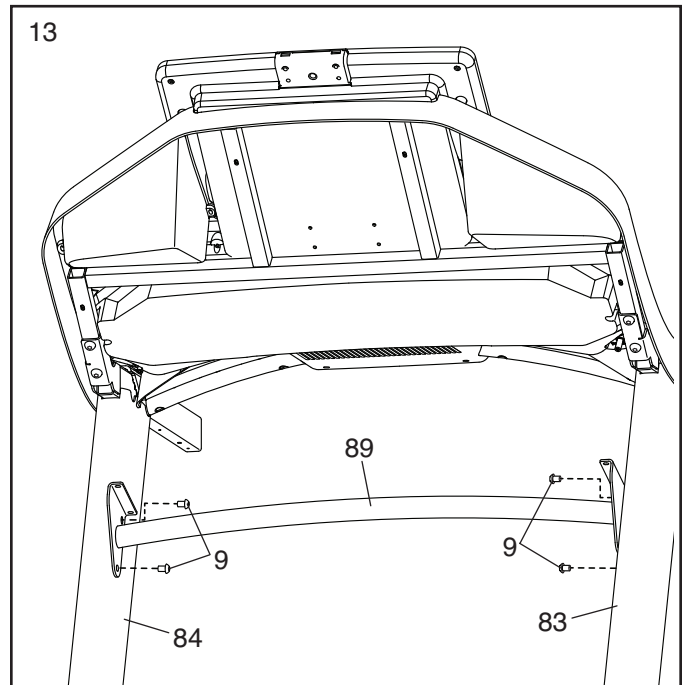

14. Attach the Tray (88) to the Upright Crossbar (89) with four #8 x 1/2" Screws (2); **start all four Screws, and then tighten them. Do not over-tighten the Screws.**

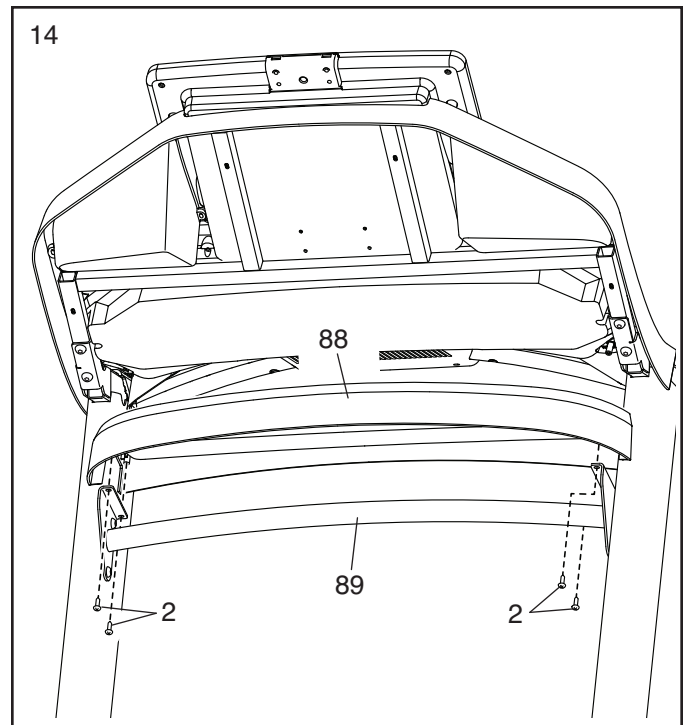

15. **Note: If the treadmill is assembled on a smooth surface, it may roll forward during this step.**

Remove the two 5/16" x 3/4" Screws (9) from the Latch Crossbar (55). Note: The Latch Crossbar is not preattached to the Frame (59).

Raise the Frame (59) to the upright position. **Have a second person hold the Frame until step 17 is completed.**

Orient the Latch Crossbar (55) as shown. **Make sure that the "This side toward belt" sticker (K) is facing the treadmill.** Attach the Latch Crossbar to the brackets (L) on the Frame (59) with the two 5/16" x 3/4" Screws (9) that you just removed and two 5/16" Star Washers (12).

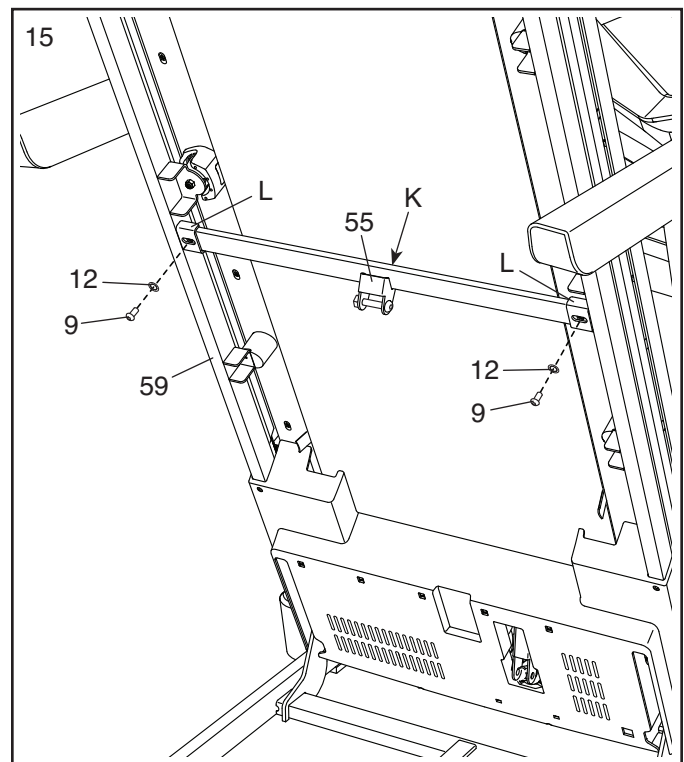

16. Remove the 5/16" Nut (36) and the 5/16" x 1 3/4" Bolt (26) from the bracket on the Base (98).

Next, orient the Storage Latch (58) as shown.

Attach the lower end of the Storage Latch (58) to the bracket on the Base (98) with the 5/16" x 1 3/4" Bolt (26) and the 5/16" Nut (36) as shown.

Then, raise the Storage Latch (58) to a vertical position, and remove the tie (M).

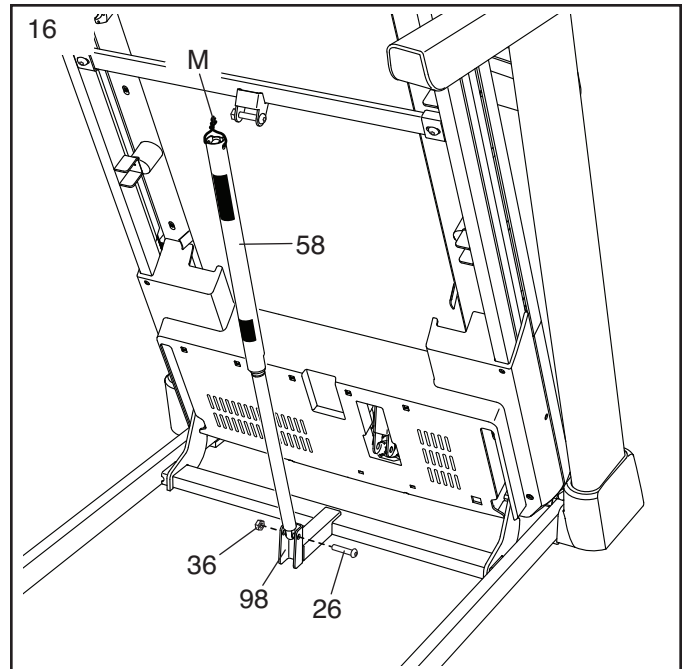

17. Remove the 5/16" Nut (36) and the 5/16" x 2 1/4" Bolt (27) from the bracket on the Latch Crossbar (55).

Align the upper end of the Storage Latch (58) with the bracket on the Latch Crossbar (55), and insert the 5/16" x 2 1/4" Bolt (27) through the bracket and the Storage Latch. **This will push a spacer (N) out of the Storage Latch; discard the spacer.**

Next, tighten the 5/16" Nut (36) onto the 5/16" x 2 1/4" Bolt (27); **do not overtighten the Nut; the Storage Latch (58) must be able to pivot.**

Then, lower the Frame (59) (see HOW TO LOWER THE TREADMILL FOR USE on page 30).

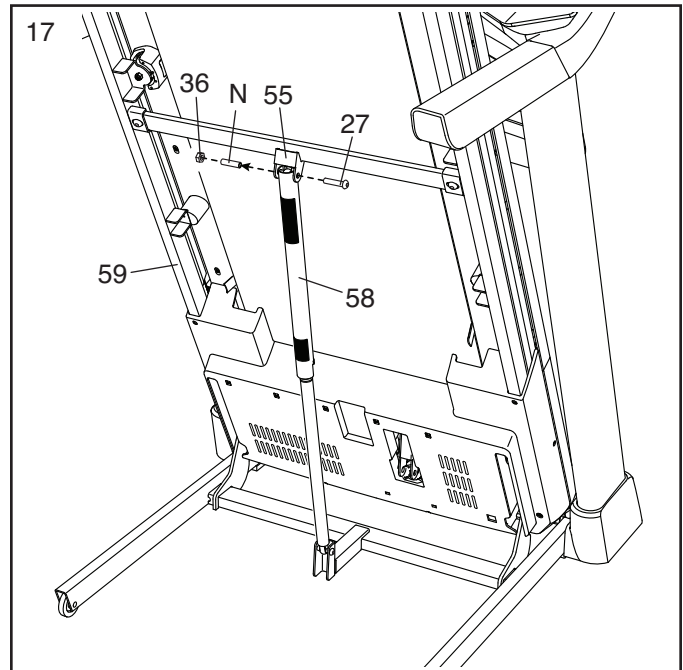

18. **Firmly tighten the four 3/8" x 2 3/8" Screws (5) and the two 3/8" x 1 1/4" Screws (7).**

**Next, tighten the two 3/8" x 1 3/4" Screws (6); make sure that the Wheels (99) turn freely.**

Next, set the Left Inner Base Cover (96) onto the lower end of the Left Upright (83). Slide the Left Base Cover (94) downward and press it onto the Left Inner Base Cover.

Then, set the Right Inner Base Cover (95) onto the lower end of the Right Upright (84). Slide the Right Base Cover (93) downward and press it onto the Right Inner Base Cover.

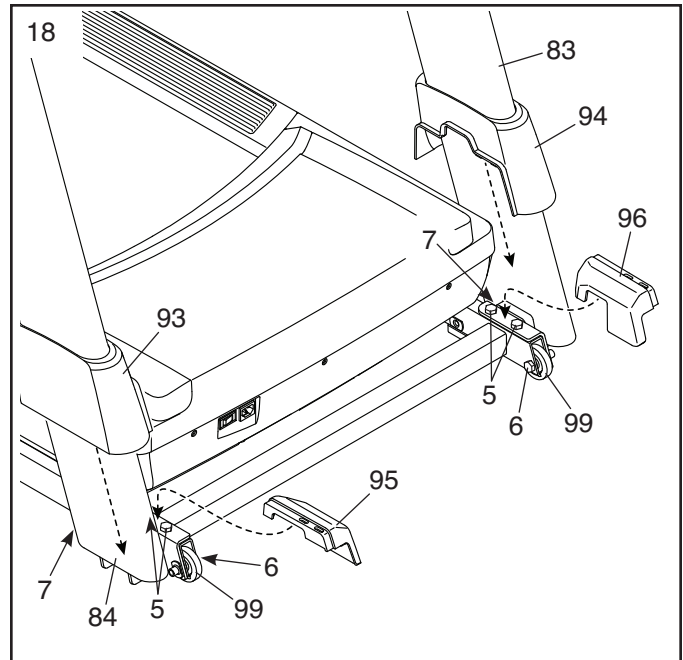

19. **Make sure that all parts are properly tightened before you use the treadmill.** If there are sheets of plastic on the treadmill decals, remove the plastic. To protect the floor or carpet, place a mat under the treadmill. To avoid damage to the console, keep the treadmill out of direct sunlight. Keep the included hex keys in a secure place; one of the hex keys is used to adjust the walking belt (see page 33). Note: Extra parts may be included.



# HOW TO USE THE TREADMILL

## HOW TO PLUG IN THE POWER CORD

**This product must be earthed.** If it should malfunction or break down, earthing provides a path of least resistance for electric current to reduce the risk of electric shock. This product's power cord has an equipment-earthing conductor and an earthing plug. **IMPORTANT: If the power cord is damaged, it must be replaced with a manufacturer-recommended power cord.**

**⚠ DANGER:** Improper connection of the equipment-earthing conductor can result in an increased risk of electric shock. Check with a qualified electrician or serviceman if you are in doubt as to whether the product is properly earthed. Do not modify the plug provided with the product—if it will not fit the outlet, have a proper outlet installed by a qualified electrician.

Follow the steps below to plug in the power cord.

1. Plug the indicated end of the power cord (A) into the socket (B) on the treadmill.

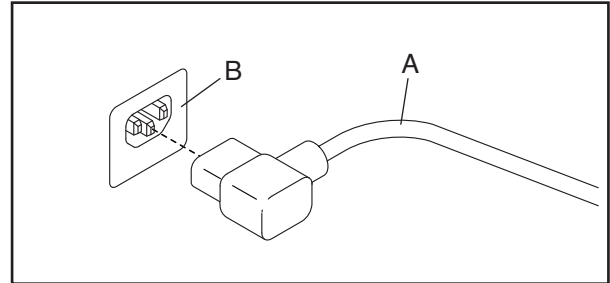

2. Plug the other end of the power cord (A) into an appropriate outlet (C) that is properly installed and earthed in accordance with all local codes and ordinances.

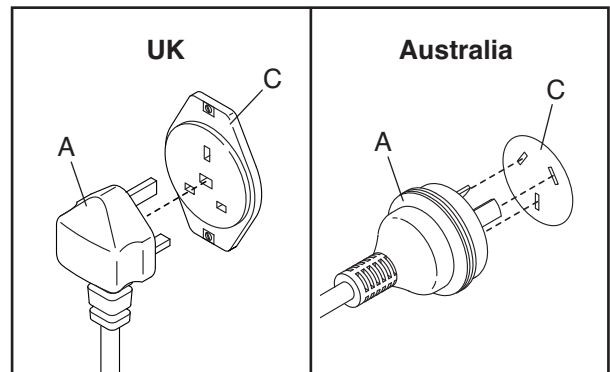

## CONSOLE DIAGRAM

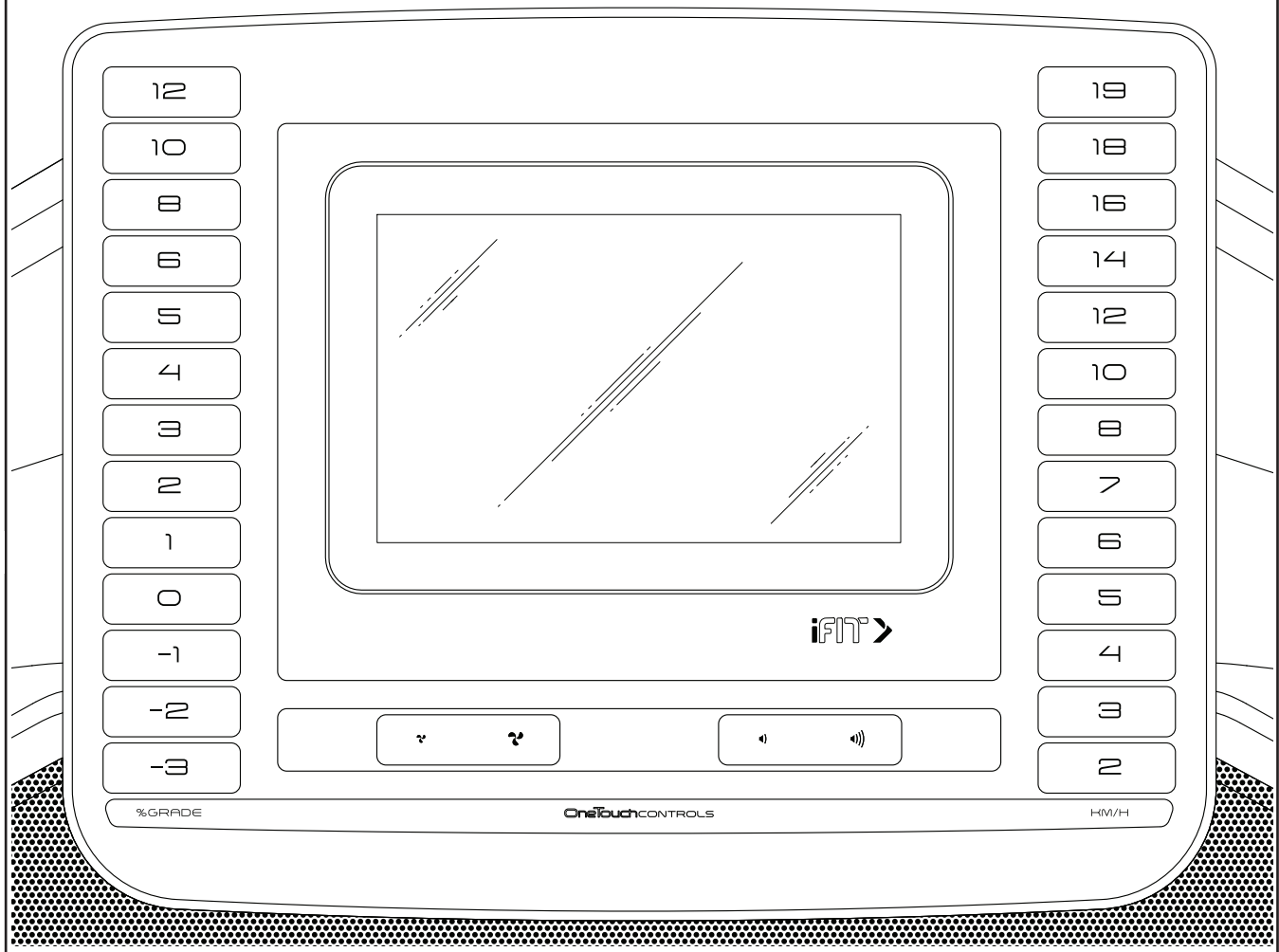

### FEATURES OF THE CONSOLE

The advanced treadmill console offers a selection of features designed to make your workouts more effective and enjoyable.

The console features wireless technology that enables the console to connect to iFIT and provide you with a rotating selection of featured iFIT workouts. Each workout automatically changes the speed and incline of the treadmill as an iFIT coach guides you through the workout.

With an iFIT subscription, you can enjoy unlimited access to iFIT's library of thousands of studio and destination workouts. You can even create your own workouts, record your workout results, set and track fitness goals, and access many other features.

When you use the manual mode of the console, you can change the speed and incline of the treadmill with the touch of a button. As you exercise, the console will display instant exercise feedback.

You can also measure your heart rate when you use a compatible heart rate monitor. **See page 29 to purchase a heart rate monitor.**

**To turn on the power**, see page 19. **To learn how to use the touch screen**, see page 19. **To set up the console**, see page 20.

## HOW TO TURN ON THE POWER

**IMPORTANT:** If the treadmill has been exposed to cold temperatures, allow it to warm to room temperature before you turn on the power. If you do not do this, you may damage the console displays or other electrical components.

Plug in the power cord (see page 17). Next, locate the power switch on the treadmill frame near the power cord. Press the power switch into the reset position (D).

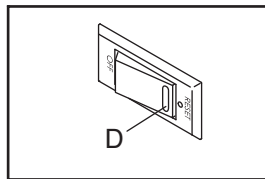

Next, stand on the foot rails of the treadmill. Locate the clip (E) attached to the key (F), and slide the clip securely onto the waistband of your clothes. Then, insert the key into the console.

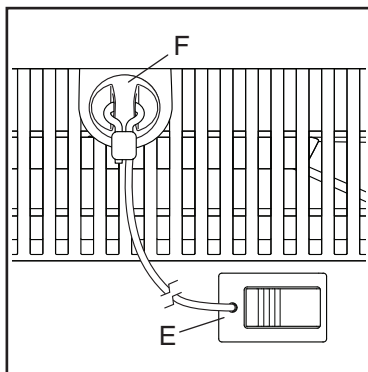

**Note: It may take some time for the console to be ready for use. IMPORTANT: In an emergency, the key can be pulled from the console, causing the walking belt to slow to a stop. Test the clip by carefully taking a few steps backward; if the key is not pulled from the console, adjust the position of the clip.**

Note: The console can display speed and distance in either miles or kilometers. To find which unit of measurement is selected, see HOW TO CHANGE CONSOLE SETTINGS on page 26.

## HOW TO USE THE TOUCH SCREEN

The console features a tablet with a full-color touch screen. The following information will help you become familiar with the tablet's advanced technology:

- The console functions similarly to other tablets. You can slide or flick your finger against the screen to move certain images on the screen, such as the displays in a workout (see step 5 on page 21). However, you cannot zoom in and out by sliding your fingers on the screen.
- The screen is not pressure sensitive. You do not need to press hard on the screen.
- To type information into a text box, first touch the text box to view the keyboard. To use numbers or other characters on the keyboard, touch *?123*. To view more characters, touch *~<*. Touch *?123* again to return to the number keyboard. To return to the letter keyboard, touch *ABC*. To use a capital character, touch the shift button (upward-facing arrow symbol). To use multiple capital characters, touch the shift button again. To return to the lowercase keyboard, touch the shift button a third time. To clear the last character, touch the clear button (backward-facing arrow with an X symbol).

## HOW TO SET UP THE CONSOLE

Before using the treadmill for the first time, set up the console.

### 1. Connect to your wireless network.

To access the internet, download iFIT workouts, and use several other features of the console, you must connect the console to a wireless network. Follow the prompts on the screen to connect the console to your wireless network.

### 2. Customize settings.

Fill in the form on the screen to set the console to display the desired unit of measurement and your time zone. Note: If you need to change these settings later, see HOW TO CHANGE CONSOLE SETTINGS on page 26.

### 3. Log into or create an iFIT account.

Provide your email address, and follow the prompts on the screen to sign up for or log into your iFIT account.

### 4. Check for firmware updates.

First, touch the menu button (three horizontal lines symbol), touch *Settings*, touch *Maintenance*, and then touch *Update*. The console will check for firmware updates. See step 5 on page 27 for more information.

### 5. Calibrate the incline system.

First, touch the menu button (three horizontal lines symbol), touch *Settings*, touch *Maintenance*, touch *Calibrate Incline*, and then touch *Begin* to calibrate the incline system. See step 6 on page 27 for more information.

The console is now ready for you to begin working out. The following pages explain the various workouts and other features that the console offers.

**To use the manual mode**, see page 21. **To use a featured workout**, see page 22. **To create a draw-your-own-map workout**, see page 24. **To use an iFIT workout**, see page 25.

**To view or change console settings**, see page 26. **To connect to a wireless network**, see page 28. **To adjust the platform cushions**, see page 29.

**IMPORTANT: If there are sheets of plastic on the console, remove the plastic. To prevent damage to the walking platform, wear clean athletic shoes while using the treadmill. The first time you use the treadmill, observe the alignment of the walking belt, and center the walking belt if necessary (see page 33).**

## HOW TO USE THE MANUAL MODE

### 1. Insert the key into the console.

See HOW TO TURN ON THE POWER on page 19.

**Note: It may take some time for the console to be ready for use.**

### 2. Select the home screen.

When you turn on the console, the home screen will appear on the screen after the console boots up.

If you are in a workout, touch the screen and follow the prompts to end the workout and return to the home screen. If you are in the settings menus, touch the back button (arrow symbol) to return to the home screen.

Note: If you plan to use a wearable heart rate monitor with the console, you must put on the heart rate monitor **before you start the walking belt**. The console will automatically search for the heart rate monitor for 30 seconds when you start the walking belt at the beginning of each workout. **See page 29 for more information about the wearable heart rate monitor.**

### 3. Start the walking belt and adjust the speed.

Touch *Manual Start* on the screen or press the Start button on the console to start the walking belt. The walking belt will begin to move at a low speed. As you exercise, change the speed of the walking belt as desired by pressing the speed increase and decrease buttons. Each time you press one of the buttons, the speed setting will change in small increments; if you hold down the button, the speed setting will change more quickly.

If you press one of the numbered speed buttons, the walking belt will gradually change speed until it reaches the selected speed setting.

### 4. Change the incline of the treadmill as desired.

To change the incline of the treadmill, press the incline increase and decrease buttons or one of the numbered incline buttons. Each time you press one of the buttons, the incline will gradually change until it reaches the selected incline setting.

**IMPORTANT: The first time you use the treadmill, you must calibrate the incline system (see step 6 on page 27).**

### 5. Follow your progress.

While you walk or run on the treadmill, a selection of workout information will be displayed:

- The incline level of the treadmill
- The elapsed time
- The approximate number of calories you have burned
- The distance that you have walked or run
- The speed of the walking belt

Additional information is also available. To view or browse additional statistics and charts, swipe down from the top of the screen. You can also touch the + button on the screen to view stats or charts.

**Note: If you wear a compatible heart rate monitor (see page 29), your heart rate will also be displayed.**

If desired, adjust the volume by pressing the volume buttons on the console.

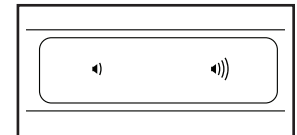

To stop the walking belt, press the Stop button or tap the screen and touch the pause symbol. To restart the walking belt, press the Start button or touch the play symbol on the screen.

## 6. Turn on the fan if desired.

The fan has several speed settings, including an auto mode.

While the auto mode is selected, the speed of the fan will automatically increase or decrease as the walking belt speed increases or decreases. Press the fan increase and decrease buttons repeatedly to select a fan speed or to turn off the fan.

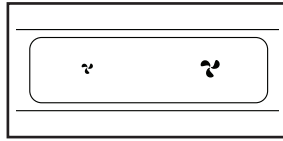

## 7. When you are finished exercising, remove the key from the console.

Step onto the foot rails and press the Stop button on the console or tap the screen and touch the pause symbol. Then, touch the stop symbol on the screen or press the Stop button again. A workout summary will appear on the screen. If you wish to save your workout for future use, you can add it as a favorite by touching the heart icon on the screen. You may also be able to either save or publish your results using one of the options on the screen. Touch *Finish* to exit to the home screen. Then, remove the key from the console and put it in a secure place.

When you are finished using the treadmill, press the power switch into the off position and unplug the power cord. **IMPORTANT: If you do not do this, the treadmill's electrical components may wear prematurely.**

## HOW TO USE A FEATURED WORKOUT

Note: To use a featured workout, the console must be connected to a wireless network (see HOW TO CONNECT TO A WIRELESS NETWORK on page 28).

### 1. Insert the key into the console.

See HOW TO TURN ON THE POWER on page 19.

**Note: It may take some time for the console to be ready for use.**

### 2. Select the home screen or the workout library.

When you turn on the power, the home screen will appear after the console boots up.

If you are in a workout, touch the screen and follow the prompts to end the workout and return to the home screen. If you are in the settings menus, touch the back button (arrow symbol) to return to the home screen.

Touch the buttons at the bottom of the screen to select either the home screen (Home button) or the workout library (Browse button).

### 3. Select a workout.

To select a workout from the home screen or the workout library, simply touch the desired workout button on the screen. Slide or flick the screen to scroll as necessary.

The featured workouts on your console will change periodically. To save one of the featured workouts for future use, you can add it as a favorite by touching the favorites button (heart symbol). You must be logged into your iFIT account to save a featured workout (see step 3 on page 25).

To draw your own map for a workout, see HOW TO CREATE A DRAW-YOUR-OWN-MAP WORKOUT on page 24.

When you select a workout, the screen will show an overview of the workout that includes details such as the duration and distance of the workout and the approximate number of calories you will burn during the workout.

#### 4. Start the workout.

Touch *Start Workout* to start the workout.

During some workouts, an iFIT coach will guide you through a video workout. Tap the screen to select separate music, trainer voice, and volume options for the workout.

During some workouts, the screen will show a map of the route and a marker indicating your progress. Touch the buttons on the screen to select the desired map options.

If the speed or incline is too high or too low, you can press the increase or decrease buttons to activate Smart Adjust and scale the intensity of the workout. **To return to the programmed settings of the workout**, touch the screen, and then turn off Smart Adjust.

**Note: The calorie goal shown in the workout description is an estimate of the number of calories that you will burn during the workout. The actual number of calories that you burn will depend on various factors, such as your weight. In addition, if you manually change the speed or incline during the workout, the number of calories you burn will be affected.**

To pause the workout, simply touch the screen and touch the pause symbol. To continue the workout, touch the play symbol.

To end the workout, touch the screen to pause the workout, and then follow the prompts on the screen to end the workout and return to the home screen.

When the workout ends, a workout summary will appear on the screen. If desired, you can select options such as adding the workout to your schedule (see HOW TO USE AN IFIT WORKOUT on page 25) or adding the workout to your favorites list. Then, touch *Finish* to return to the home screen.

#### 5. Use headphones if desired.

To connect your wireless headphones to the console, first turn on your headphones, place them in pairing mode, and place them near the console. Then, touch the screen in any open space, touch the option to connect your headphones, and select your headphones from the list on the screen.

When your headphones and the console pair successfully, the audio from the console will play through your headphones.

#### 6. Follow your progress.

See step 5 on page 21.

#### 7. Turn on the fan if desired.

See step 6 on page 22.

#### 8. When you are finished exercising, remove the key from the console.

See step 7 on page 22.

## HOW TO CREATE A DRAW-YOUR-OWN-MAP WORKOUT

Note: To create a draw-your-own-map workout, the console must be connected to a wireless network (see HOW TO CONNECT TO A WIRELESS NETWORK on page 28). An iFIT account is also required.

### 1. Insert the key into the console.

See HOW TO TURN ON THE POWER on page 19.

**Note: It may take some time for the console to be ready for use.**

### 2. Select a draw your own map workout.

To select a draw your own map workout, touch *Create* on the screen.

### 3. Draw your map.

Navigate to the area on the map where you want to draw your workout by sliding your fingers on the screen. Tap the screen to add the start point for your workout. Then, tap the screen to add the end point for your workout. Note: If you want to start and end the workout at the same point, use the *Close Loop* or *Out & Back* options. You can also select whether you want your workout to snap to the road.

If you make a mistake, you can touch *Undo*.

The screen will display the elevation and distance for your workout. If desired, you can change the default speed.

### 4. Save your workout.

Touch *Save New Workout* on the screen. If desired, you can change the title of the workout or add a description.

### 5. Start the workout.

Touch *Start Workout* on the screen to start the workout. A moment after you touch the button, the walking belt will begin to move. Hold the handrails and begin walking. See step 4 on page 23 for more information.

### 6. Follow your progress.

See step 5 on page 21.

### 7. Turn on the fan if desired.

See step 6 on page 22.

### 8. When you are finished exercising, remove the key from the console.

See step 7 on page 22.



## HOW TO USE AN iFIT WORKOUT

To use an iFIT workout, the console must be connected to a wireless network (see HOW TO CONNECT TO A WIRELESS NETWORK on page 28). An iFIT account is also required.

### 1. Insert the key into the console.

See HOW TO TURN ON THE POWER on page 19.

**Note: It may take some time for the console to be ready for use.**

### 2. Select the home screen.

When you turn on the console, the home screen will appear on the screen after the console boots up.

If you are in a workout, touch the screen and follow the prompts to end the workout and return to the home screen. If you are in the settings menus, touch the back button (arrow symbol) to return to the home screen.

### 3. Log in to your iFIT account.

If you have not already done so, touch the menu button (three horizontal lines symbol) on the screen and then touch *Log in* to log in to your iFIT account. Follow the prompts on the screen to enter your username and password.

To switch users within your iFIT account, touch the menu button, touch *Settings*, and then touch *Manage Accounts*. If more than one user is associated with the account, a list of users will appear. Touch the name of the desired user.

### 4. Select an iFIT workout from the home screen or the workout library.

Touch the buttons at the bottom of the screen to select either the home screen (Home button) or the workout library (Browse button).

To select an iFIT workout from the home screen or the workout library, simply touch the desired workout button on the screen. Slide or flick the screen to scroll upward or downward if necessary.

The featured iFIT workouts shown on the home screen will change periodically.

The workout library contains all of the iFIT workouts available for the treadmill, organized into categories. To search the workout library, touch the search button (magnifying glass symbol), and select the desired filtering options.

When you select an iFIT workout, the screen will show an overview of the workout that includes details such as the duration of the workout and the approximate number of calories you will burn during the workout.

You can also select options such as adding the workout to your schedule (see step 5) or marking the workout as a favorite (see step 6).

### 5. Schedule an iFIT workout on the calendar if desired.

If desired, you can schedule an iFIT workout for a future date. Simply view the overview or workout summary of the desired iFIT workout, touch *Schedule*, and then select the desired date on the calendar.

When the selected date arrives, the iFIT workout that you scheduled will appear on the home screen.

## 6. Create a list of favorite iFIT workouts if desired.

To mark an iFIT workout as a favorite, simply view the overview or workout summary of the desired iFIT workout and touch the favorites button (heart symbol).

To view a list of iFIT workouts that you have marked as your favorites, select the workout library (Browse button), and then touch *My List*.

## 7. Start the workout.

Touch *Start Workout* on the screen to start the workout. A moment after you touch the button, the walking belt will begin to move. Hold the handrails and begin walking. See step 4 on page 23 for more information.

## 8. Use headphones if desired.

To connect your wireless headphones to the console, first turn on your headphones, place them in pairing mode, and place them near the console. Then, touch the screen in any open space, touch the option to connect your headphones, and select your headphones from the list on the screen.

When your headphones and the console pair successfully, the audio from the console will play through your headphones.

## 9. Follow your progress.

See step 5 on page 21.

## 10. Turn on the fan if desired.

See step 6 on page 22.

## 11. When you are finished exercising, remove the key from the console.

See step 7 on page 22.

**For more information about iFIT, go to [iFIT.com](https://www.ifit.com).**

## HOW TO CHANGE CONSOLE SETTINGS

**IMPORTANT: Some of the settings and features described may not be enabled.** Occasionally, a firmware update may cause your console to function slightly differently.

### 1. Select the settings menu.

First, turn on the power and insert the key into the console (see HOW TO TURN ON THE POWER on page 19). **Note: It may take some time for the console to be ready for use.**

Next, select the home screen. When you turn on the console, the home screen will appear on the screen after the console boots up. If you are in a workout, tap the screen, touch the pause symbol, touch the stop symbol, and then touch *Finish* to return to the home screen.

Next, touch the menu button (three horizontal lines symbol), and then touch *Settings*. The settings menu will appear on the screen.

### 2. Navigate the settings menus and change settings as desired.

Slide or flick the screen to scroll upward or downward if necessary. To view a settings menu, simply touch the menu name. To exit a menu, touch the back button (arrow symbol). You may be able to view and change settings in the following settings menus:

Account

- My Profile
- In Workout
- Manage Accounts

Equipment

- Equipment Info
- Equipment Settings
- Maintenance
- Wi-Fi

About

- Legal

### 3. Customize the time zone and other settings.

To customize the time zone or other settings, touch *Equipment Settings* and then touch the desired settings.

### 4. View machine information.

Touch *Equipment Info* to view app or machine info or to change the unit of measurement.

The console can display speed and distance in either standard or metric units of measurement.

### 5. Update the console firmware.

**For the best results, regularly check for firmware updates.** Touch *Maintenance*, and then touch *Update* to check for firmware updates using your wireless network. The update will begin automatically. **IMPORTANT: To avoid damaging the console, do not turn off or unplug the treadmill while the firmware is being updated.**

The screen will show the progress of the update. When the update is complete, the treadmill will turn off and then turn back on. If it does not, use the power switch (see HOW TO TURN ON THE POWER on page 19) to turn the treadmill off, wait for a few seconds, and then turn it back on again. Note: It may take a few minutes for the console to be ready for use.

Note: Occasionally, a firmware update may cause the console to function slightly differently. These updates are always designed to improve your exercise experience.

### 6. Calibrate the incline system of the treadmill.

Touch *Calibrate Incline*, and then touch *Begin* to calibrate the incline system. The treadmill will automatically rise to the maximum incline level and then return to the starting position. This will calibrate the incline system. When the incline system is calibrated, touch *Finish*. **Note: Occasionally, the incline calibration may run automatically when you turn on the treadmill. Wait for the calibration to be completed before attempting to use the treadmill.**

**IMPORTANT: Keep pets, feet, and other objects away from the treadmill while the incline system is calibrating. In an emergency, pull the key from the console to stop the incline calibration.**

### 7. Exit the settings menu.

If you are in a settings menu, touch the back button (arrow symbol) to exit.

## HOW TO CONNECT TO A WIRELESS NETWORK

The console is Wi-Fi enabled, allowing you to set up a wireless network connection.

### 1. Select the home screen.

See step 2 on page 21.

### 2. Select the wireless network menu.

Touch the menu button (three horizontal lines symbol), and then touch the Wi-Fi® symbol to enter the wireless network menu.

### 3. Enable Wi-Fi.

Make sure that Wi-Fi is enabled. If it is not, touch the Wi-Fi toggle to enable a wireless connection.

### 4. Set up and manage a wireless network connection.

When Wi-Fi is enabled, the screen will show a list of available networks. Note: It may take several seconds for the list of wireless networks to appear.

Note: You must have your own wireless network and an 802.11b/g/n router with SSID broadcast enabled (hidden networks are not supported).

When a list of networks appears, touch the desired network. Note: You will need to know your network name (SSID). If your network has a password, you will also need to know the password.

An information box will ask if you want to connect to the wireless network. Touch *Join* to connect to the network or touch *Cancel* to return to the list of networks. If the network has a password, touch the password entry box. A keyboard will appear on the screen. To view the password as you type it, touch the *Show Password* checkbox.

To use the keyboard, see HOW TO USE THE TOUCH SCREEN on page 19.

When the console is connected to your wireless network, a checkmark will appear next to the wireless network name.

To disconnect from a wireless network, touch and hold the name of the wireless network and then touch *Forget*.

If you are having problems connecting to an encrypted network, make sure that your password is correct. Note: Passwords are case-sensitive.

Note: The console supports unsecured and secured (WEP, WPA™, and WPA2™) encryption. A broadband connection is recommended; performance depends on connection speed.

**Note: If you have questions after following these instructions, go to [support.iFIT.com](http://support.iFIT.com) for assistance.**

### 5. Exit the wireless network menu.

To exit the wireless network menu, touch the back button (arrow symbol) on the screen.

## HOW TO ADJUST THE CUSHIONS

The treadmill features a cushioning system that reduces the impact as you walk or run on the treadmill.

To adjust the cushions, first **remove the key from the console and unplug the power cord**. You may also need to place the treadmill in the storage position (see HOW TO FOLD THE TREADMILL on page 30).

For a more firm walking platform, turn a cushion to the position shown in drawing 1; for a less firm walking platform, turn the cushion to the position shown in drawing 2. Adjust the other cushions in the same way.

**Note: Make sure that the cushions on the left and right sides of the treadmill are set to the same firmness level. The faster you run on the treadmill, or the more you weigh, the firmer the walking platform should be.**

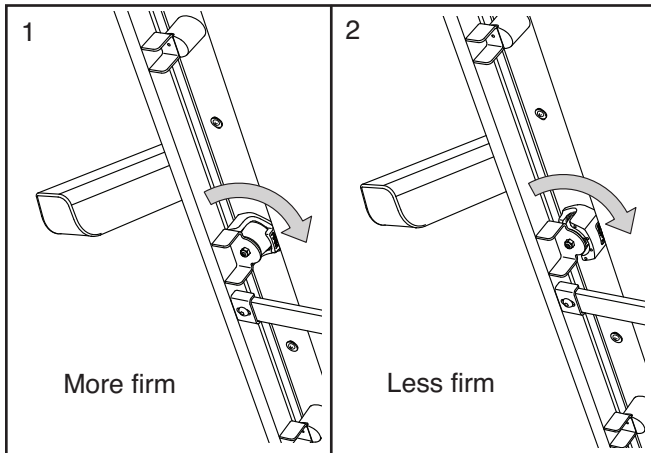

## THE OPTIONAL HEART RATE MONITOR

Whether your goal is to burn fat or to strengthen your cardiovascular system, the key to achieving the best results is to maintain the proper heart rate during your workouts.

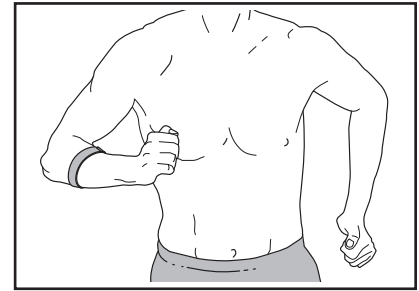

A wearable rate monitor will enable you to continuously monitor your heart rate while you exercise, helping you to reach your personal fitness goals. **To purchase a wearable heart rate monitor, please see the front cover of this manual.**

Note: The console is compatible with all Bluetooth Smart heart rate monitors.

To connect a wearable heart rate monitor to the console, first put it on as directed in its included instructions. Then, begin a workout or start the walking belt in the manual mode. The console will search for the wearable heart rate monitor for 30 seconds and connect automatically.

# HOW TO FOLD AND MOVE THE TREADMILL

## HOW TO FOLD THE TREADMILL

To avoid damaging the treadmill, adjust the incline to zero before you fold the treadmill. Then, remove the key and unplug the power cord. **CAUTION:** You must be able to safely lift 45 lbs. (20 kg) to raise, lower, or move the treadmill.

1. Hold the metal frame (A) firmly in the location shown by the arrow below. **CAUTION: Do not hold the frame by the plastic foot rails. Bend your legs and keep your back straight.**

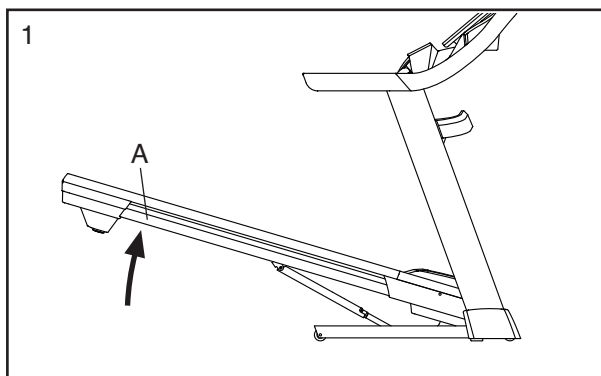

2. Raise the frame (A) until the storage latch (B) locks in the storage position. **CAUTION: Make sure that the storage latch locks.**

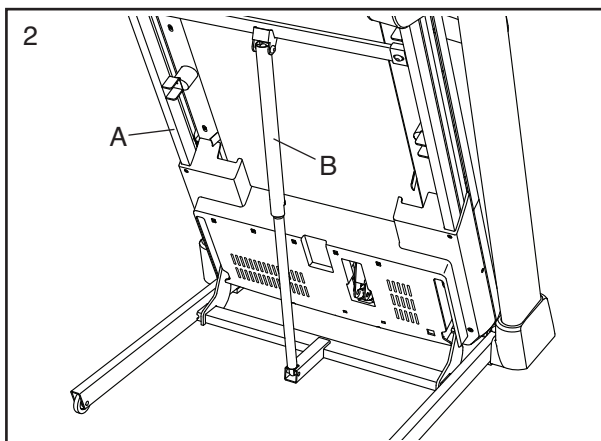

To protect the floor or carpet, place a mat under the treadmill. Keep the treadmill out of direct sunlight. Do not leave the treadmill in the storage position in temperatures above 85°F (30°C).

## HOW TO MOVE THE TREADMILL

Before moving the treadmill, fold it as described at the left. **CAUTION: Make sure that the storage latch is in the locked position. Moving the treadmill may require two people. Take any necessary measures to protect your floor.**

Hold the handrails (C) with both hands and carefully push the treadmill to the desired location. **CAUTION: Do not pull on the frame, and do not move the treadmill over an uneven surface.**

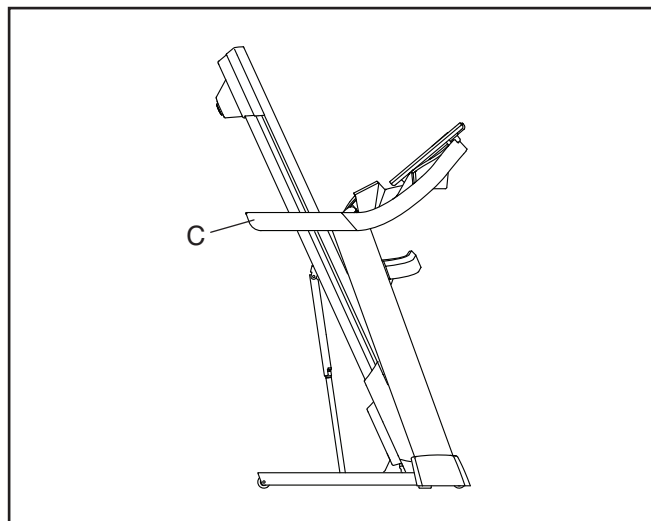

## HOW TO LOWER THE TREADMILL FOR USE

1. Push the upper end of the frame forward, and gently press the footprint decal on the storage latch with your foot at the same time.
2. While pressing the storage latch with your foot, pull the upper end of the frame toward yourself.
3. Step back and let the frame lower to the floor.

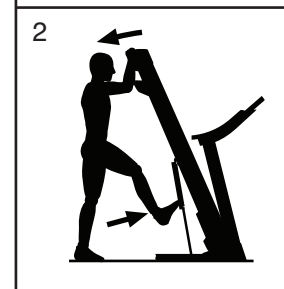
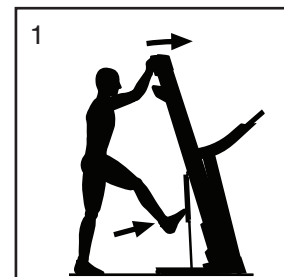

# MAINTENANCE AND TROUBLESHOOTING

## MAINTENANCE

Regular maintenance is important for optimal performance and to reduce wear. Inspect and properly tighten all parts each time the treadmill is used. Replace any worn parts immediately. Use only manufacturer-supplied parts.

Regularly clean the treadmill and keep the walking belt clean and dry. First, **press the power switch into the off position and unplug the power cord.** Wipe exterior parts of the treadmill with a damp cloth and a small amount of mild soap. **IMPORTANT: Do not spray liquids directly onto the treadmill. To avoid damage to the console, keep liquids away from the console.** Then, thoroughly dry the treadmill with a soft towel.

## TROUBLESHOOTING

**Most treadmill problems can be solved by following the simple steps below. Find the symptom that applies, and follow the steps listed. If further assistance is needed, see the front cover of this manual.**

### **SYMPTOM: The power does not turn on**

- If an extension cord is needed, use only a 3-conductor, 14-gauge (2 mm<sup>2</sup>) cord that is no longer than 5 ft. (1.5 m).
- After the power cord has been plugged in, make sure that the key is inserted into the console.
- Check the power switch located on the treadmill frame near the power cord. If the switch protrudes as shown (A), the switch has tripped. To reset the power switch, wait for five minutes and then press the switch back in (B).

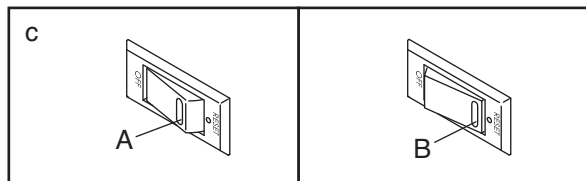

### **SYMPTOM: The power turns off during use**

- Check the power switch (see drawing c at the left). If the switch has tripped, wait for five minutes and then press the switch back in.
- Make sure that the power cord is plugged in. If the power cord is plugged in, unplug it, wait for five minutes, and then plug it back in.
- Remove the key from the console, and then reinsert it.
- If the treadmill still will not run, please see the front cover of this manual.

### **SYMPTOM: The incline of the treadmill does not change correctly**

- Calibrate the incline system (see step 6 on page 27).

### **SYMPTOM: The treadmill will not connect to the wireless network**

- Make sure that the wireless settings on the console are correct (see page 28).
- Make sure that the settings for your wireless network are correct.
- If you still have questions, see the front cover of this manual.

**SYMPTOM: The displays of the console do not function properly**

- a. If the console does not properly record speed or distance, remove the key from the console and **UNPLUG THE POWER CORD**. Next, remove the five #8 x 3/4" Pan Head Screws (13), and carefully pivot off the Motor Hood (65).

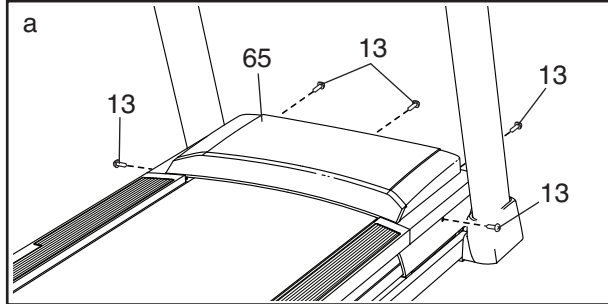

Next, locate the Reed Switch (112) and the Magnet (114) on the left side of the Pulley (51). Turn the Pulley until the Magnet is aligned with the Reed Switch. **Make sure that the gap between the Magnet and the Reed Switch is about 1/8 in. (3 mm).** If necessary, loosen the #8 x 3/4" Screw (3), move the Reed Switch slightly, and then retighten the Truss Head Screw. Reattach the Motor Hood (see above), and walk on the treadmill for a few minutes to check for a correct speed reading.

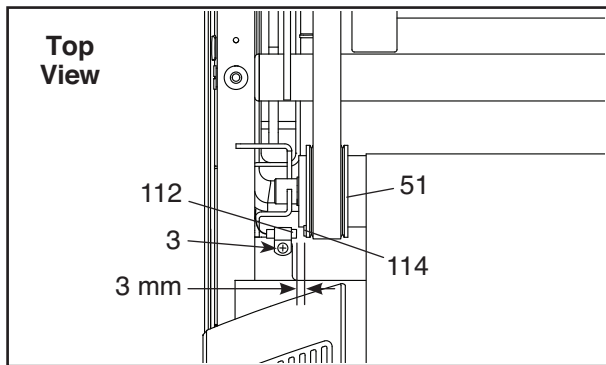

- b. If the console does not boot up properly, or if the console freezes and does not respond, reset the console to the factory default settings.

**IMPORTANT: Doing this will erase all the custom settings you have made to the console.**

Resetting the console requires two people. First, press the power switch into the off position. Next, locate the small reset opening (C) on the back edge of the console. Using a bent paper clip (D), press and hold the reset button inside the opening, and have a second person press the power switch into the on (reset) position. Continue holding the reset button (C) until the console turns on. When the reset operation is complete, the console will turn off and then turn back on. If it does not, use the power switch to turn the treadmill off and then on again. Once the console turns on, check for firmware updates (see step 5 on page 27). Note: It may take a few minutes for the console to be ready for use.

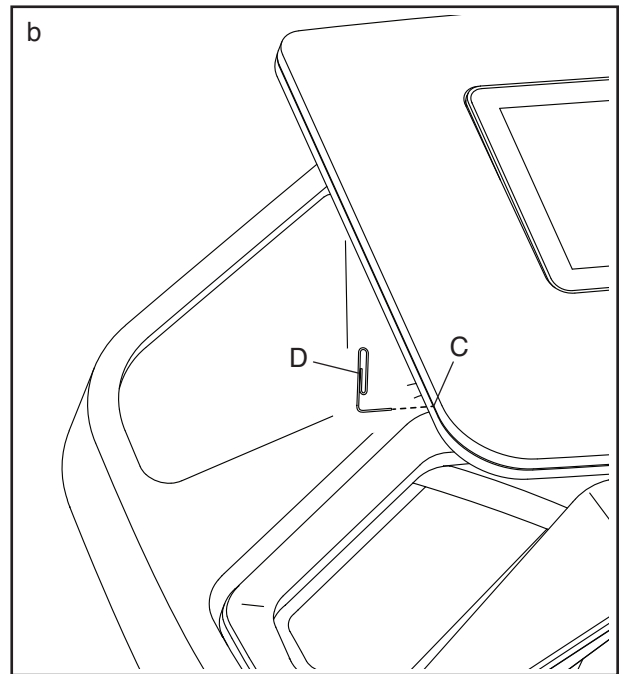



**SYMPTOM: The walking belt slows when walked on**

- a. If an extension cord is needed, use only a 3-conductor, 14-gauge (2 mm<sup>2</sup>) cord that is no longer than 5 ft. (1.5 m).
- b. If the walking belt is overtightened, treadmill performance may decrease and the walking belt may become damaged. Remove the key and **UNPLUG THE POWER CORD**. Using the hex key, turn both idler roller screws (E) counterclockwise, 1/4 of a turn. When the walking belt is properly tightened, you should be able to lift each edge of the walking belt 2 to 3 in. (5 to 7 cm) off the walking platform. Be careful to keep the walking belt centered. Then, plug in the power cord, insert the key, and walk on the treadmill for a few minutes. Repeat until the walking belt is properly tightened.

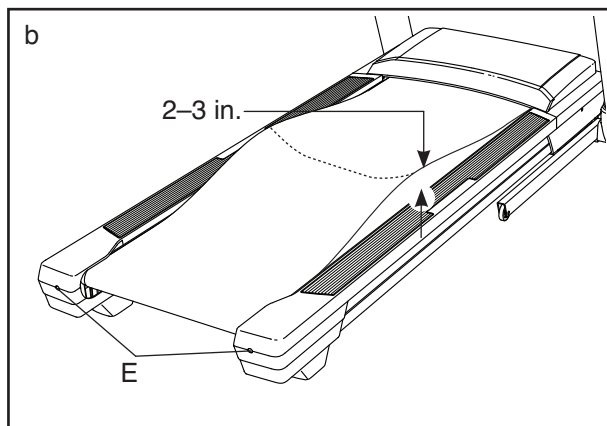

- c. Your treadmill features a walking belt coated with high-performance lubricant. **IMPORTANT: Never apply silicone spray or other substances to the walking belt or the walking platform unless instructed to do so by an authorized service representative. Such substances may deteriorate the walking belt and cause excessive wear.** If you suspect that the walking belt needs more lubricant, see the front cover of this manual.
- d. If the walking belt still slows when walked on, see the front cover of this manual.

**SYMPTOM: The walking belt is not centered between the foot rails**

- a. **IMPORTANT: If the walking belt rubs against the foot rails (F), the walking belt may become damaged.** First, remove the key and **UNPLUG THE POWER CORD**. If the walking belt has shifted to the left, use the hex key to turn the left idler roller screw clockwise 1/2 of a turn; if the walking belt has shifted to the right, turn the left idler roller screw counterclockwise 1/2 of a turn. Be careful not to overtighten the walking belt. Then, plug in the power cord, insert the key, and walk on the treadmill for a few minutes. Repeat until the walking belt is centered.

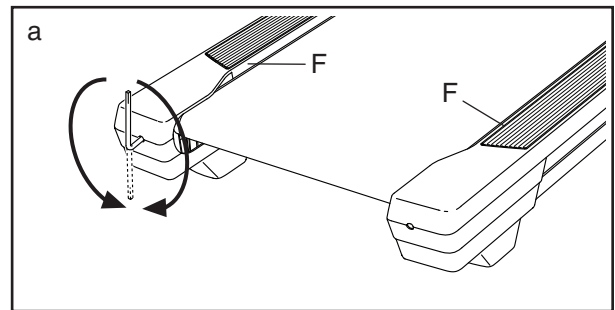

**SYMPTOM: The walking belt slips when walked on**

- a. First, remove the key and **UNPLUG THE POWER CORD**. Using the hex key, turn both idler roller screws clockwise, 1/4 of a turn. When the walking belt is correctly tightened, you should be able to lift each edge of the walking belt 2 to 3 in. (5 to 7 cm) off the walking platform. Be careful to keep the walking belt centered. Then, plug in the power cord, insert the key, and walk on the treadmill for a few minutes. Repeat until the walking belt is properly tightened.

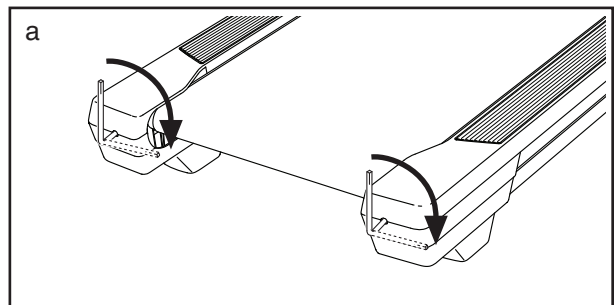

# EXERCISE GUIDELINES

**⚠️ WARNING:** Before beginning this or any exercise program, consult your physician. This is especially important for persons over age 35 or persons with pre-existing health problems.

These guidelines will help you to plan your exercise program. For detailed exercise information, obtain a reputable book or consult your physician. Remember, proper nutrition and adequate rest are essential for successful results.

## EXERCISE INTENSITY

Whether your goal is to burn fat or to strengthen your cardiovascular system, exercising at the proper intensity is the key to achieving results. You can use your heart rate as a guide to find the proper intensity level. The chart below shows recommended heart rates for fat burning and aerobic exercise.

165	155	145	140	130	125	115	♥️
145	138	130	125	118	110	103	♥️
125	120	115	110	105	95	90	♥️
20	30	40	50	60	70	80	

To find the proper intensity level, find your age at the bottom of the chart (ages are rounded off to the nearest ten years). The three numbers listed above your age define your “training zone.” The lowest number is the heart rate for fat burning, the middle number is the heart rate for maximum fat burning, and the highest number is the heart rate for aerobic exercise.

**Burning Fat**—To burn fat effectively, you must exercise at a low intensity level for a sustained period of time. During the first few minutes of exercise, your body uses carbohydrate calories for energy. Only after the first few minutes of exercise does your body begin to use stored fat calories for energy. If your goal is to burn fat, adjust the intensity of your exercise until your heart rate is near the lowest number in your training zone. For maximum fat burning, exercise with your heart rate near the middle number in your training zone.

**Aerobic Exercise**—If your goal is to strengthen your cardiovascular system, you must perform aerobic exercise, which is activity that requires large amounts of oxygen for prolonged periods of time. For aerobic exercise, adjust the intensity of your exercise until your heart rate is near the highest number in your training zone.

## HOW TO MEASURE YOUR HEART RATE

To measure your heart rate, exercise for at least four minutes. Then, stop exercising and place two fingers on your wrist as shown. Take a six-second heartbeat count, and multiply the result by 10 to find your heart rate. For example, if your six-second heartbeat count is 14, your heart rate is 140 beats per minute.

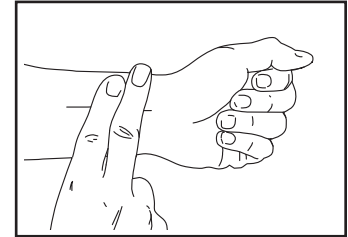

## WORKOUT GUIDELINES

**Warming Up**—Start with 5 to 10 minutes of stretching and light exercise. A warm-up increases your body temperature, heart rate, and circulation in preparation for exercise.

**Training Zone Exercise**—Exercise for 20 to 30 minutes with your heart rate in your training zone. (During the first few weeks of your exercise program, do not keep your heart rate in your training zone for longer than 20 minutes.) Breathe regularly and deeply as you exercise; never hold your breath.

**Cooling Down**—Finish with 5 to 10 minutes of stretching. Stretching increases the flexibility of your muscles and helps to prevent post-exercise problems.

## EXERCISE FREQUENCY

To maintain or improve your condition, complete three workouts each week, with at least one day of rest between workouts. After a few months of regular exercise, you may complete up to five workouts each week, if desired. Remember, the key to success is to make exercise a regular and enjoyable part of your everyday life.

## SUGGESTED STRETCHES

The correct form for several basic stretches is shown at the right. Move slowly as you stretch—never bounce.

### 1. Toe Touch Stretch

Stand with your knees bent slightly and slowly bend forward from your hips. Allow your back and shoulders to relax as you reach down toward your toes as far as possible. Hold for 15 counts, then relax. Repeat 3 times. Stretches: Hamstrings, back of knees and back.

### 2. Hamstring Stretch

Sit with one leg extended. Bring the sole of the opposite foot toward you and rest it against the inner thigh of your extended leg. Reach toward your toes as far as possible. Hold for 15 counts, then relax. Repeat 3 times for each leg. Stretches: Hamstrings, lower back and groin.

### 3. Calf/Achilles Stretch

With one leg in front of the other, reach forward and place your hands against a wall. Keep your back leg straight and your back foot flat on the floor. Bend your front leg, lean forward and move your hips toward the wall. Hold for 15 counts, then relax. Repeat 3 times for each leg. To cause further stretching of the achilles tendons, bend your back leg as well. Stretches: Calves, achilles tendons and ankles.

### 4. Quadriceps Stretch

With one hand against a wall for balance, reach back and grasp one foot with your other hand. Bring your heel as close to your buttocks as possible. Hold for 15 counts, then relax. Repeat 3 times for each leg. Stretches: Quadriceps and hip muscles.

### 5. Inner Thigh Stretch

Sit with the soles of your feet together and your knees outward. Pull your feet toward your groin area as far as possible. Hold for 15 counts, then relax. Repeat 3 times. Stretches: Quadriceps and hip muscles.

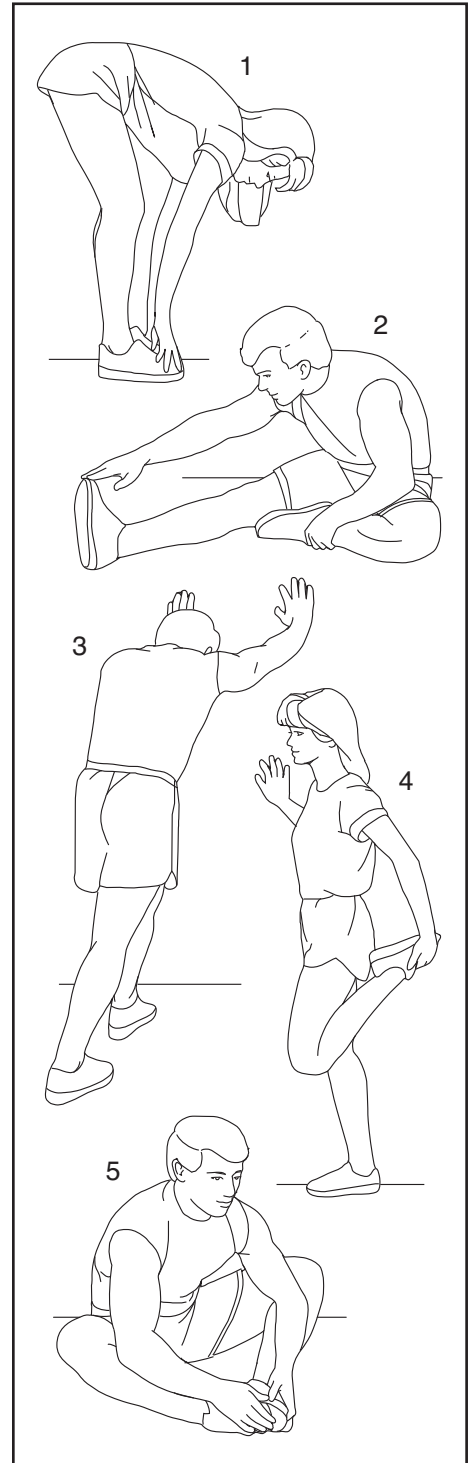

---

# NOTES

---

# NOTES

# PART LIST

Model No. NTL15421-INT.4 R1121A

Key No.	Qty.	Description	Key No.	Qty.	Description
1	1	M4 x 13mm Screw	51	1	Idler Roller/Pulley
2	6	#8 x 1/2" Screw	52	1	Controller Clamp
3	9	#8 x 3/4" Screw	53	1	Controller Plate
4	4	#10 x 3/4" Screw	54	4	Plastic Tie
5	4	3/8" x 2 3/8" Screw	55	1	Latch Crossbar
6	2	3/8" x 1 3/4" Screw	56	1	Drive Motor
7	2	3/8" x 1 1/4" Screw	57	1	Motor Belt
8	4	5/16" x 2 1/2" Screw	58	1	Storage Latch
9	6	5/16" x 3/4" Screw	59	1	Frame
10	8	3/8" Star Washer	60	1	Right Rear Foot
11	4	#10 Star Washer	61	1	Left Rear Foot
12	6	5/16" Star Washer	62	2	Rear Foot
13	38	#8 x 3/4" Pan Head Screw	63	1	Idler Roller
14	2	3/8" x 1 3/8" Bolt	64	1	Hood Accent
15	3	1/4" x 2 1/2" Screw	65	1	Motor Hood
16	2	3/8" x 1 1/8" Bolt	66	2	Incline Frame Spacer
17	2	1/4" x 1 1/4" Screw	67	4	3/8" Plastic Bushing
18	4	1/4" x 1" Bolt	68	2	Frame Spacer
19	16	#8 x 3/4" Tek Screw	69	1	Incline Motor
20	8	#8 x 5/8" Screw	70	1	Incline Frame
21	4	1/4" x 1/2" Screw	71	2	Incline Motor Spacer
22	1	3/8" x 1 3/4" Bolt	72	1	Power Cord
23	1	3/8" x 1 1/2" Bolt	73	1	Receptacle
24	2	5/16" Motor Screw	74	1	Controller
25	4	#8 x 7/16" Screw	75	1	Power Switch
26	5	5/16" x 1 3/4" Bolt	76	1	Belly Pan
27	1	5/16" x 2 1/4" Bolt	77	1	Left Top Handrail Cover
28	5	#8 x 1/2" Washer Head Screw	78	1	Right Top Handrail Cover
29	1	#8 x 1/2" Machine Screw	79	1	Left Bottom Handrail Cover
30	2	3/8" Washer	80	1	Right Bottom Handrail Cover
31	4	#8 Star Washer	81	1	Left Handrail
32	4	5/16" Flat Washer	82	1	Right Handrail
33	5	1/4" Nut	83	1	Left Upright
34	8	#8 x 3/8" Screw	84	1	Right Upright
35	6	3/8" Nut	85	1	Left Crossbar Cover
36	6	5/16" Nut	86	1	Right Crossbar Cover
37	4	1/4" Star Washer	87	1	Crossbar
38	2	Adjustable Cushion	88	1	Upright Tray
39	4	Cushion	89	1	Upright Crossbar
40	1	Warning Decal	90	1	Upright Wire
41	1	Walking Platform	91	2	Upright Grommet
42	1	Walking Belt	92	2	Base Foot
43	1	Left Frame Cover	93	1	Right Base Cover
44	1	Right Frame Cover	94	1	Left Base Cover
45	1	Left Foot Rail	95	1	Right Inner Base Cover
46	1	Right Foot Rail	96	1	Left Inner Base Cover
47	2	Belt Guide	97	2	Caution Decal
48	4	Rubber Cushion	98	1	Base
49	2	3/8" Pin	99	4	Wheel
50	2	9/32" Plastic Bushing	100	1	Console

Key No.	Qty.	Description	Key No.	Qty.	Description
101	1	Console Base	111	5	Hood Clip
102	1	Left Tray	112	1	Reed Switch
103	1	Right Tray	113	1	Clip
104	1	Fan	114	1	Magnet
105	4	Fan Screw	115	2	Motor Bushing
106	2	Console Frame Cap	116	1	Filter
107	1	Console Frame	117	3	#8 Nut
108	1	Console Ground Wire	118	3	#8 x 1/2" Machine Screw
109	3	Cable Tie	119	1	Motor Isolator
110	1	Key/Clip	*	–	User's Manual

Note: Specifications are subject to change without notice. For information about ordering replacement parts, see the back cover of this manual. \*These parts are not illustrated.

# EXPLODED DRAWING A

Model No. NTL15421-INT.4 R1121A

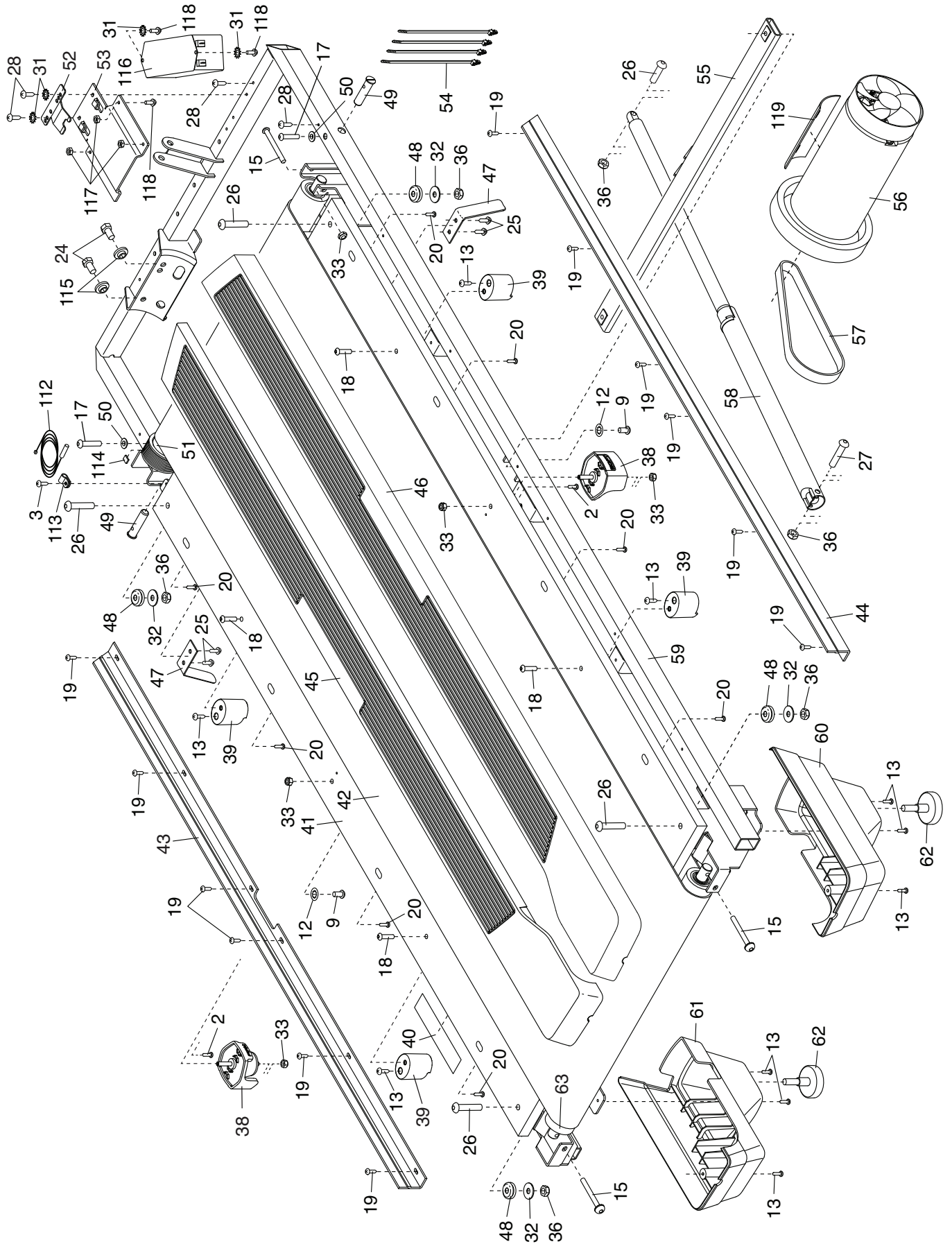



# EXPLODED DRAWING B

Model No. NTL15421-INT.4 R1121A

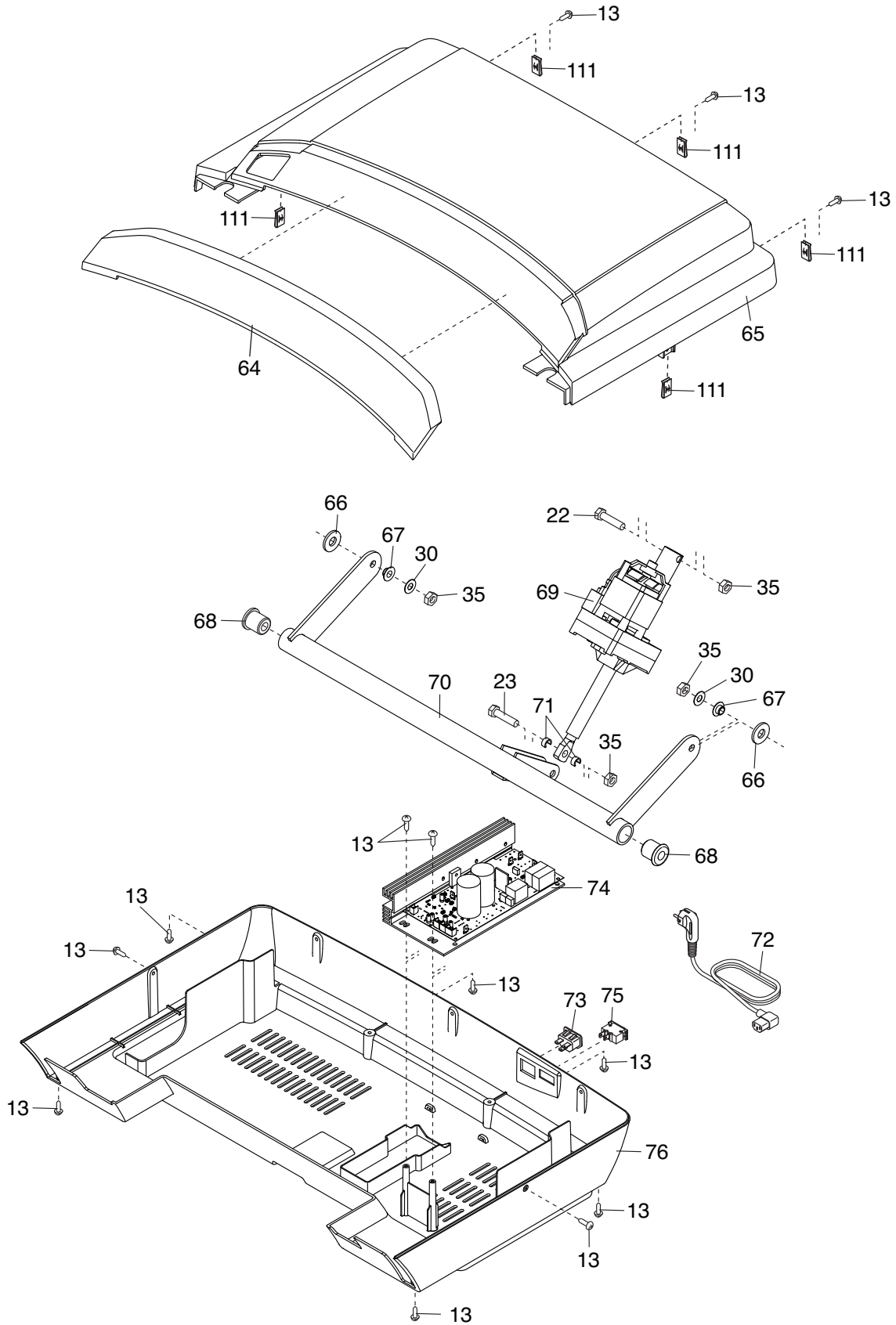

# EXPLODED DRAWING C

Model No. NTL15421-INT.4 R1121A

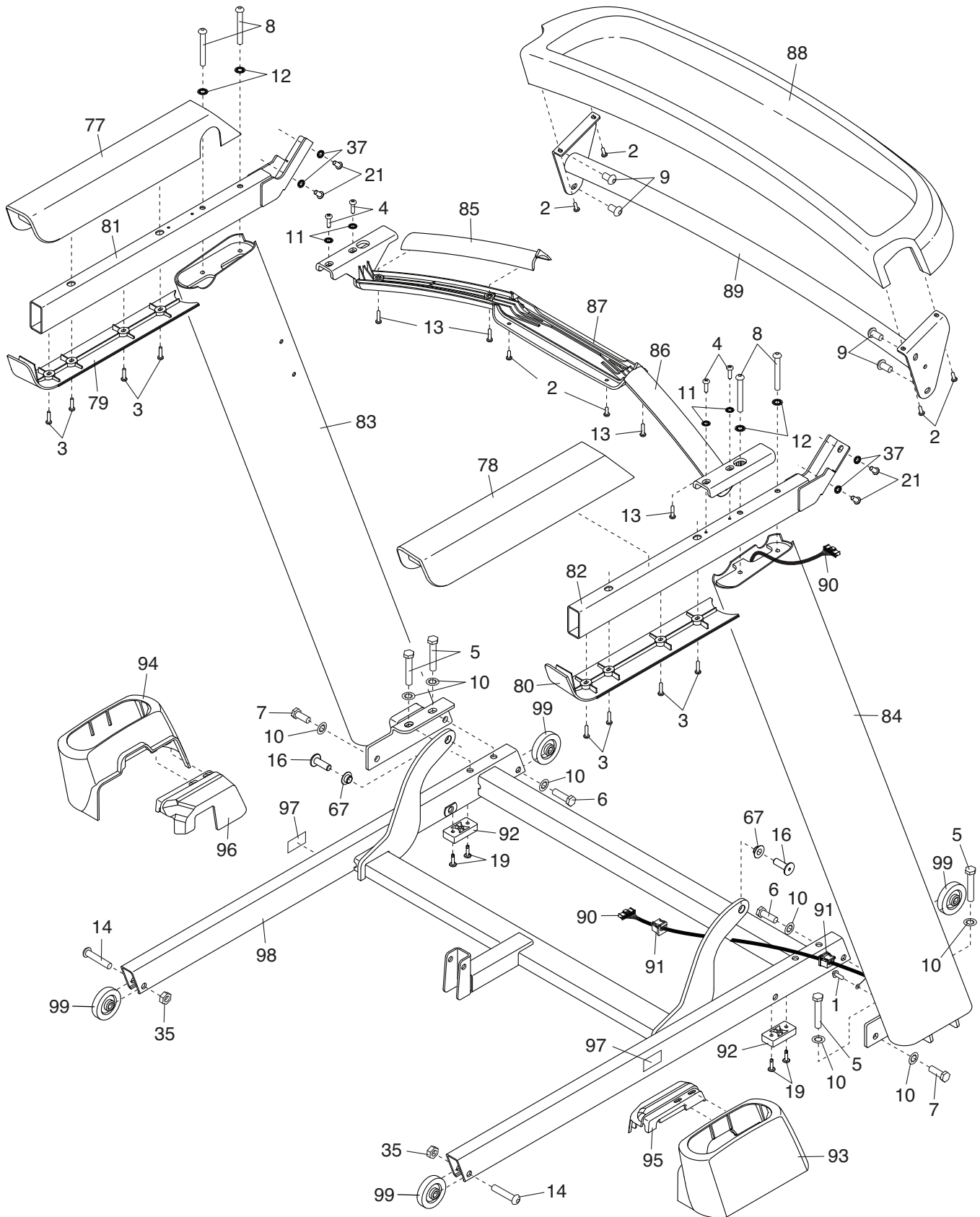

# EXPLODED DRAWING D

Model No. NTL15421-INT.4 R1121A

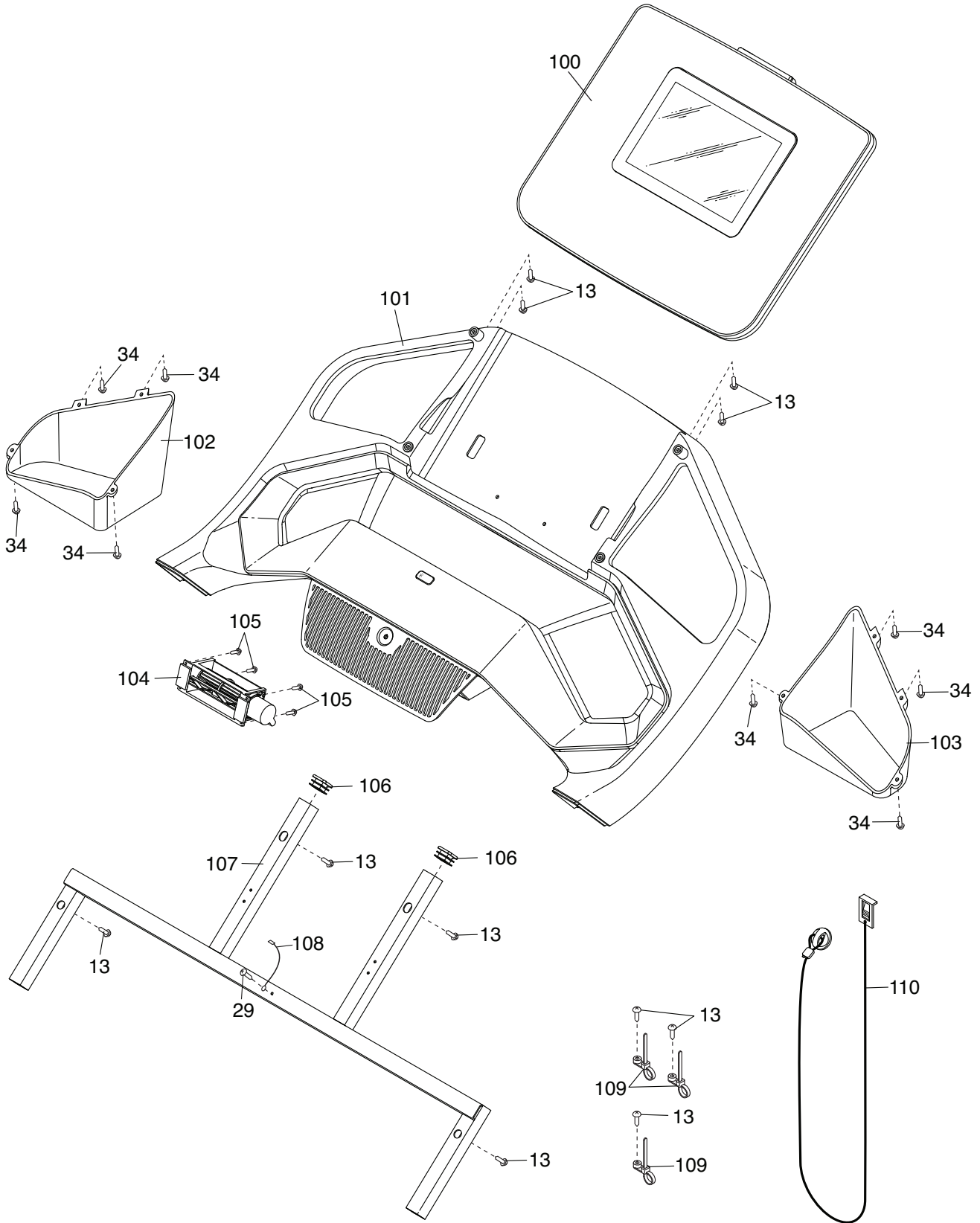

---

## ORDERING REPLACEMENT PARTS

To order replacement parts, please see the front cover of this manual. To help us assist you, be prepared to provide the following information when contacting us:

- the model number and serial number of the product (see the front cover of this manual)
- the name of the product (see the front cover of this manual)
- the key number and description of the replacement part(s) (see the PART LIST and the EXPLODED DRAWING near the end of this manual)

---

## RECYCLING INFORMATION

**This electronic product must not be disposed of in municipal waste. To preserve the environment, this product must be recycled after its useful life as required by law.**

Please use recycling facilities that are authorized to collect this type of waste in your area. In doing so, you will help to conserve natural resources and improve European standards of environmental protection. If you require more information about safe and correct disposal methods, please contact your local city office or the establishment where you purchased this product.

