

TAURUS®

Assembly and Operating Instructions



Art. No. TF-UF



Art. No. TF-UF-PRO



max. 135 kg



~ 150 Min. 



 80 kg

L 134 | W 165 | H 208

TFUF.01.05

Multi-gym Ultra Force

Content

1	GENERAL INFORMATION	7
1.1	Technical Data	7
1.2	Personal Safety	8
1.3	Set-Up Place	9
2	ASSEMBLY	10
2.1	General Instructions	10
2.2	Scope of Delivery	10
2.3	Parts Overview	12
2.4	Warning notes/warning sticker	13
2.5	Assembly	17
3	STORAGE AND TRANSPORT	32
3.1	General Instructions	32
3.2	Transportation Wheels	32
4	WORKOUT INSTRUCTIONS	33
4.1	General training instructions	33
4.2	Exercise and safety notes	34
4.3	Exercise manual	35
4.4	Equipment settings	35
4.5	Stretching exercises for leg & chest muscles	37
4.6	Workout journal	39
5	TROUBLESHOOTING, CARE AND MAINTENANCE	40
5.1	General Instructions	40
5.2	Faults and Fault Diagnosis	40
5.3	Maintenance and Inspection Calendar	41
6	DISPOSAL	41
7	RECOMMENDED ACCESSORIES	42

8	ORDERING SPARE PARTS	43
8.1	Serial Number and Model Name	43
8.2	Parts List	44
8.3	Exploded Drawing	48
9	WARRANTY	49
10	CONTACT	51

Dear customer,

Thank you for choosing a high-quality equipment of the brand Taurus®. Taurus® offers sports and fitness equipment for the sophisticated home sport and the equipment of fitness studios and business customers. With Taurus® fitness equipment, the focus is on what sport is all about: maximum performance! Therefore, the equipment is developed in close consultation with athletes and sports scientists. Because athletes know best what makes perfect fitness equipment.

Further information can be found at www.sport-tiedje.com.

Intended Use

The equipment may only be used for its intended purpose.

The equipment is only suitable for home use. The equipment is not suitable for semi-professional (e.g. hospitals, associations, hotels, schools, etc.) and commercial or professional use (e.g. fitness studios).

Legal Notice

Sport-Tiedje GmbH
Europe's No. 1 for home fitness

International Headquarters
Flensburger Straße 55
24837 Schleswig
Germany

Management:
Christian Grau
Sebastian Campmann
Dr. Bernhard Schenkel
No. HRB 1000 SL
Local Court Flensburg
European VAT Number: DE813211547

Disclaimer



©2011 Taurus® is a registered brand of the company SportTiedje GmbH. All rights reserved. Any use of this trademark without the explicit written permission of Sport-Tiedje is prohibited.

Product and manual are subject to change. Technical data can be changed without advance notice.

ABOUT THIS MANUAL

Please carefully read the entire manual before installation and first use. The manual will help you to quickly set up the system and explains how to safely use it. Make sure that all people exercising with the equipment (especially children and people with physical, sensory, mental or motor disabilities) are informed about this manual and its contents in advance. In case of doubt, responsible people must supervise the use of the equipment.

Due to ongoing changes and software optimisations, the manual may have to be updated. If you notice any discrepancies during assembly or use, please refer to the manual uploaded to the webshop. The latest manual is always available there.

This equipment has been manufactured according to the latest safety knowledge. As far as possible, potential safety hazards which could cause injury have been eliminated. Make sure to carefully follow the instructions and that all parts are securely in place. If required, read through the instructions again to correct any mistakes.



Please pay close attention to the safety and maintenance instructions given here. The contract partner cannot be held liable for damage to health, accidents or damage to the equipment when it is not used in accordance with these instructions.

The following safety instructions may appear in this manual:

► **ATTENTION**

This notice indicates potentially hazardous situations which, if not avoided, may result in property damage.

⚠ **CAUTION**

This notice indicates potentially hazardous situations which, if not avoided, may result in slight or minor injuries!

⚠ **WARNING**

This notice indicates potentially hazardous situations which, if not avoided, may result in death or serious injuries!

⚠ **DANGER**

This notice indicates potentially hazardous situations which, if not avoided, will result in death or serious injuries!

ⓘ **NOTICE**

This notice indicates further useful information.

Retain these instructions in a safe place for future reference, maintenance or when ordering replacement parts.

1.1 Technical Data

TF-UF

Weight and Dimensions:

Article weight (gross, incl. packaging): 88.6 kg

Article weight (net, without packaging): 80 kg

Packaging dimensions (L x W x H) and weight:

Box 1 approx. 151 cm x 49 cm x 22 cm 42 kg

Box 2 approx. 116 cm x 85 cm x 16 cm 46.6 kg

Set-up dimensions (L x W x H): approx. 134 cm x 165 cm x 208 cm

Maximum user weight: 135 kg

Resistance system: Hydraulic

Maximum resistance: 100 kg, adjustable in 1.25 kg increments

TF-UF-PRO

Weight and Dimensions:

Article weight (gross, incl. packaging): 87 kg

Article weight (net, without packaging): 80 kg

Packaging dimensions (L x W x H) and weight:

Box 1 approx. 151 cm x 52 cm x 22 cm 42 kg

Box 2 approx. 116 cm x 85 cm x 16 cm 45 kg

Set-up dimensions (L x W x H): approx. 134 cm x 165 cm x 208 cm

Maximum user weight: 135 kg

Resistance system: Hydraulic

Maximum resistance: 125 kg, adjustable in 1.25 kg increments

1.2 Personal Safety

DANGER

- + Before you start using the equipment, you should consult your physician that this type of exercise is suitable for you from a health perspective. Particularly affected are people who: have a hereditary disposition to high blood pressure or heart disease, are over the age of 45, smoke, have high cholesterol values, are overweight and/or have not exercised regularly in the past year. If you are under medical treatment that affects your heart rate, medical advice is absolutely essential.
- + Note that excessive training can seriously endanger your health. Please also note that heart rate monitoring systems can be inaccurate. If you notice any signs of weakness, nausea, dizziness, pain, shortness of breath, or other abnormal symptoms, stop exercising immediately and seek advice from your doctor if necessary.

WARNING

- + This equipment may not be used by children under the age of 14.
- + Children should not be allowed unsupervised access to the equipment.
- + People with disabilities must have a medical license and must be under strict observation when using the equipment.
- + The equipment is strictly for use by one person at a time.
- + If your equipment provides a safety key, the clip of the safety key must be attached to your clothing before starting your training. In the event of a fall, the EMERGENCY STOP of the equipment can be initiated.
- + Keep your hands, feet and other body parts, hair, clothing, jewellery and other objects well clear of moving parts.
- + During use, wear suitable sports clothing rather than loose or baggy clothing. When wearing sports shoes, make sure they have suitable soles, preferably made of rubber or other non-slip materials. Shoes with heels, leather soles, studs or spikes are unsuitable. Never exercise barefoot.

CAUTION

- + If your equipment needs to be connected to the power supply with a mains cable, make sure that the cable is not a potential tripping hazard.
- + Make sure that nobody is within the range of motion of the equipment during training so as not to endanger you or other people.

ATTENTION

- + Do not insert any objects of any kind into the openings of the device.

1.3 Set-Up Place

WARNING

- + Do not place the equipment in main corridors or escape routes.

CAUTION

- + Choose a location in which to place the equipment such that there is enough free space/clearance to the front, the rear and to the sides of the equipment.
- + The training room should be well ventilated during training and not be exposed to any draughts.
- + Choose the place in which to set up the equipment such that there is enough free space/clearance to the front, the rear and to the sides of the equipment.
- + The set-up and mounting surface of the equipment should be flat, loadable and solid.
- + If your device is to be mounted on the wall/ceiling, make sure that you use the appropriate assembly material to avoid possible damages or personal injuries. The contractual partner accepts no liability for this.

ATTENTION

- + The device may only be used in one building, in sufficiently tempered and dry rooms (ambient temperatures between 10°C and 35°C). The equipment should not be used outdoors or in rooms with high humidity (over 70%) like swimming pools.
- + A floor protective mat/equipment underlay can help to protect high-quality floor coverings (parquet, laminate, cork, carpets) from dents and sweat and can help to level out slight unevenness.

2.1 General Instructions



DANGER

- + Do not leave any tools, packaging materials such as foils or small parts lying around, as otherwise there is a danger of suffocation for children. Keep children away from the equipment during assembly.



WARNING

- + Pay attention to the instructions attached to the equipment in order to reduce the risk of injuries.



CAUTION

- + Ensure to have sufficient room for movement in each direction during assembly.
- + The assembly of the equipment must be carried out by at least two adults. If in doubt, seek the help of a third technically skilled person.



ATTENTION

- + To prevent damage to the equipment and the floor, assemble the equipment on a mat or packaging board.



NOTICE

- + In order to make the assembly as simple as possible, some screws and nuts to be used can already be pre-assembled.
- + Ideally, assemble the equipment at its later set-up place.

2.2 Scope of Delivery

The scope of delivery consist of the following parts. At the beginning, check whether all parts and tools belonging to the device are included in the scope of delivery and whether damage has occurred. In the event of complaints, the contractual partner must be contacted directly.



CAUTION

If parts of the scope of delivery are missing or damaged, the assembly must not be carried out.



NOTICE

The graphics shown in these assembly and operating instructions may differ slightly from the product you have purchased (Ultra Force or Ultra Force Pro). The graphics used in these assembly and operating instructions refer to the "Ultra Force" variant. However, the assembly procedure remains identical.

BOX 1



Fastener Pack

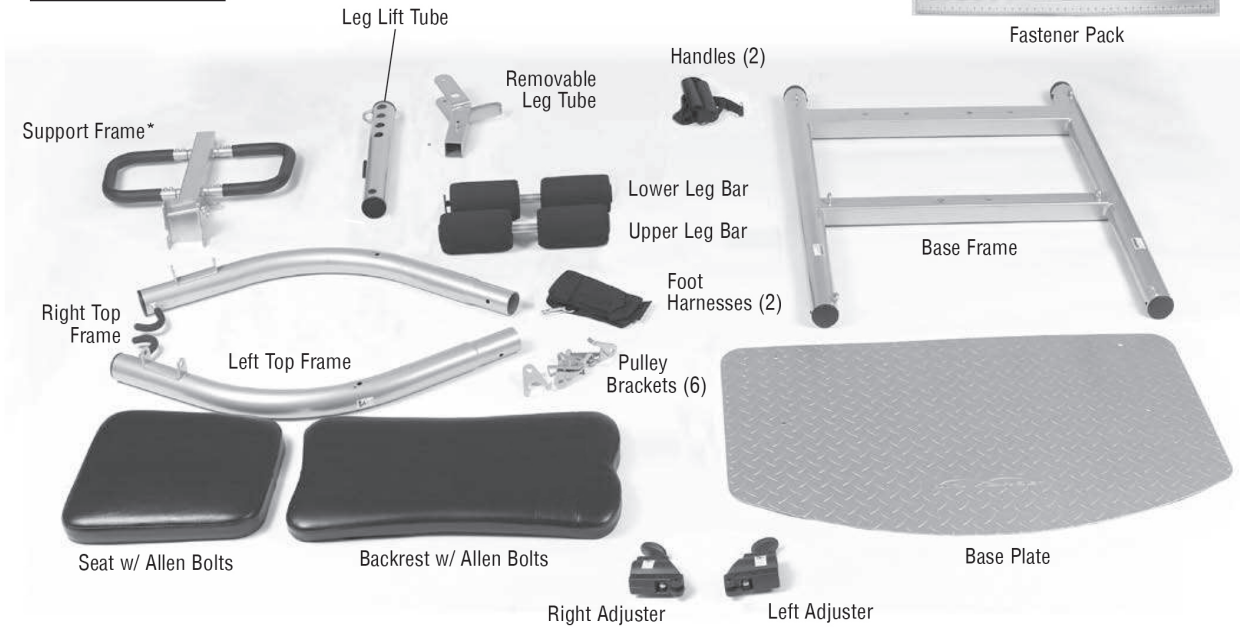

*Important: The Left and Right Seat Handlebars are attached to the Support Frame

BOX 2

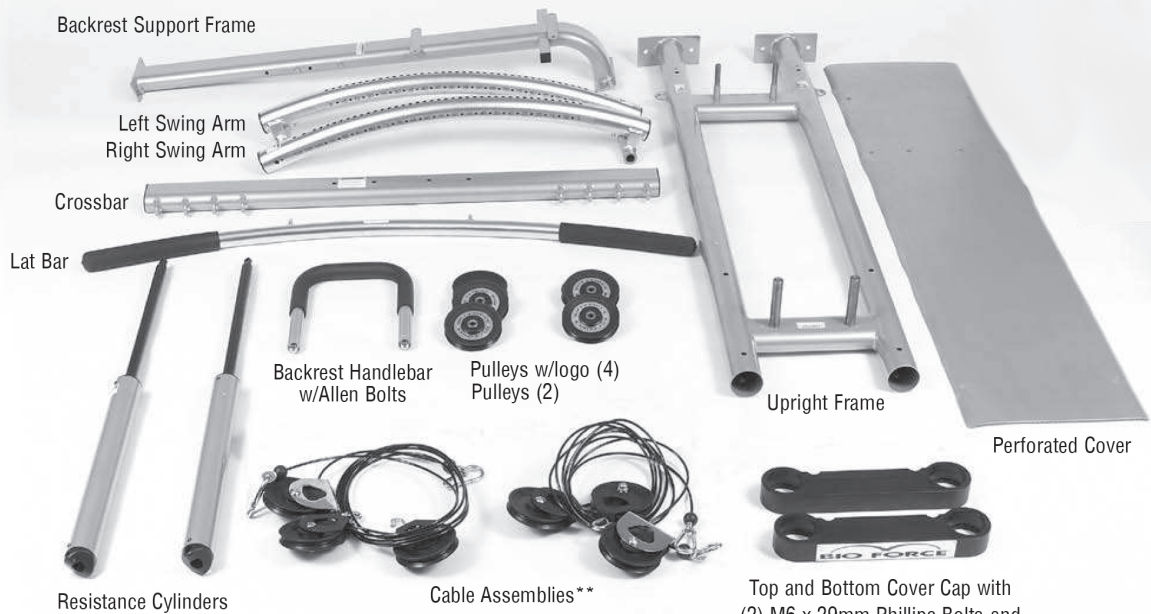

**Important: Each Cable Assembly consists of the Cable, 1 Chrome Pulley and 2 Padded Pulleys

2.3 Parts Overview

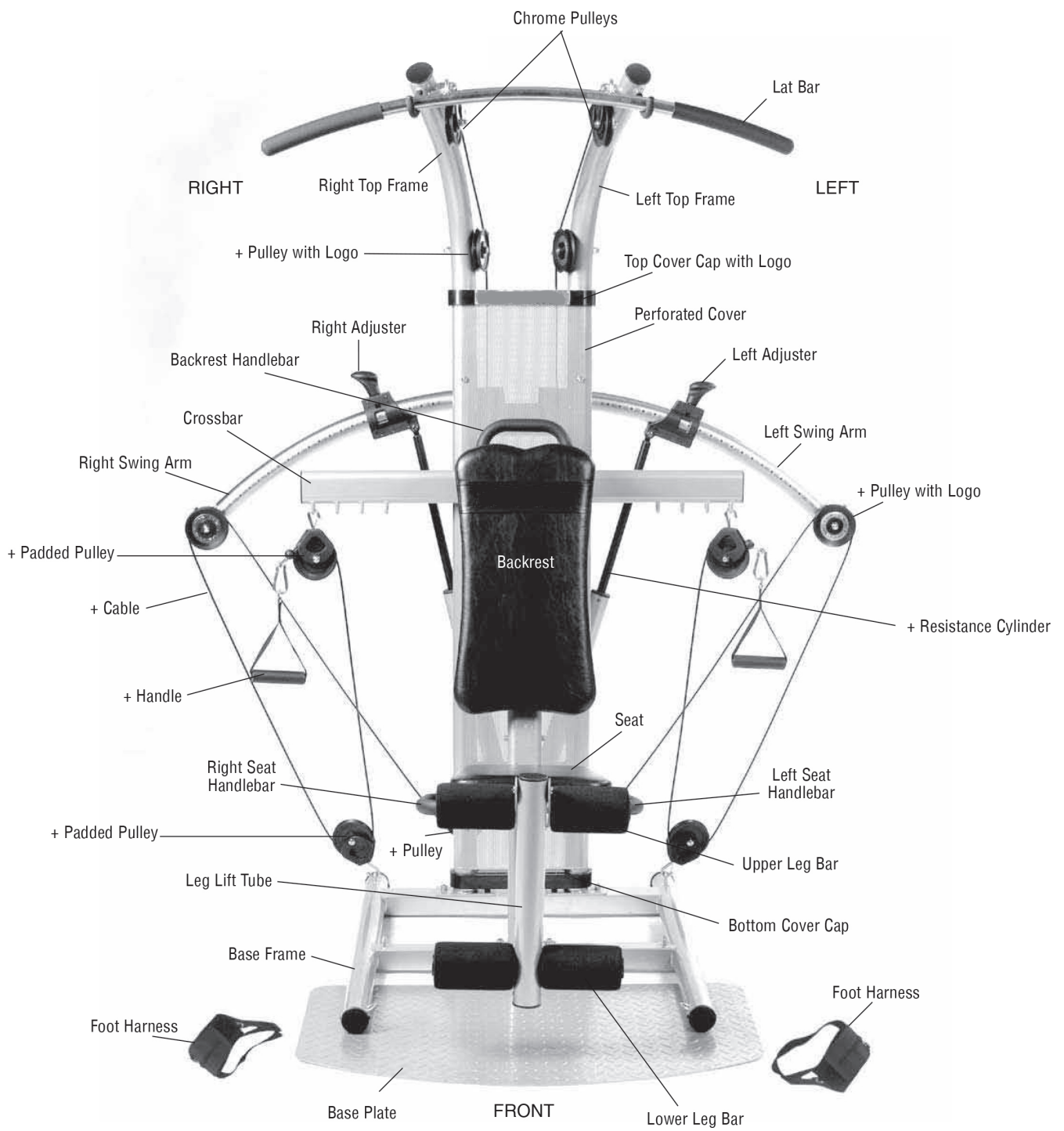

2.4 Warning notes/warning sticker



IMPORTANT: Please observe the attachment of the following warning and attention stickers on your equipment:

CAUTION LABEL 1

If you are not using the lat bar, always hang it in the holder.

WARNING LABEL 1

If you do not read and follow the safety instructions provided in the user instructions and video, this MAY RESULT IN SERIOUS INJURIES OR DEATH. KEEP AWAY FROM CHILDREN. Maximum user weight: 330 lbs/150 kg. Replace this sticker if it is damaged, illegible or was removed. Class HC.

WARNING LABEL 2

Crushing hazard: Keep hands away during assembly and disassembly.

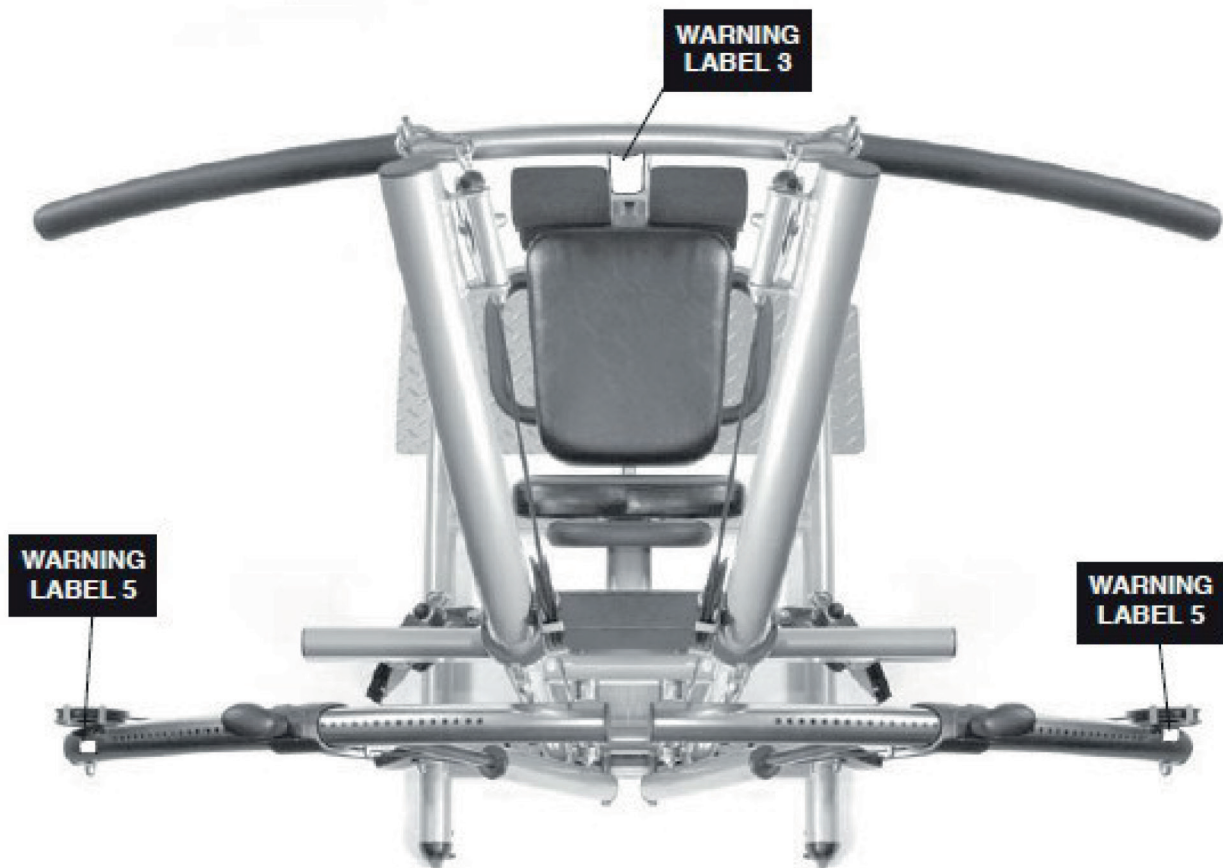

WARNING LABEL 3

WARNING LABEL 5

WARNING LABEL 5

WARNING LABEL 3

Crushing hazard! Keep hands away while using!

WARNING LABEL 5 (6 positions)

Do not touch the pulleys and mobile parts.

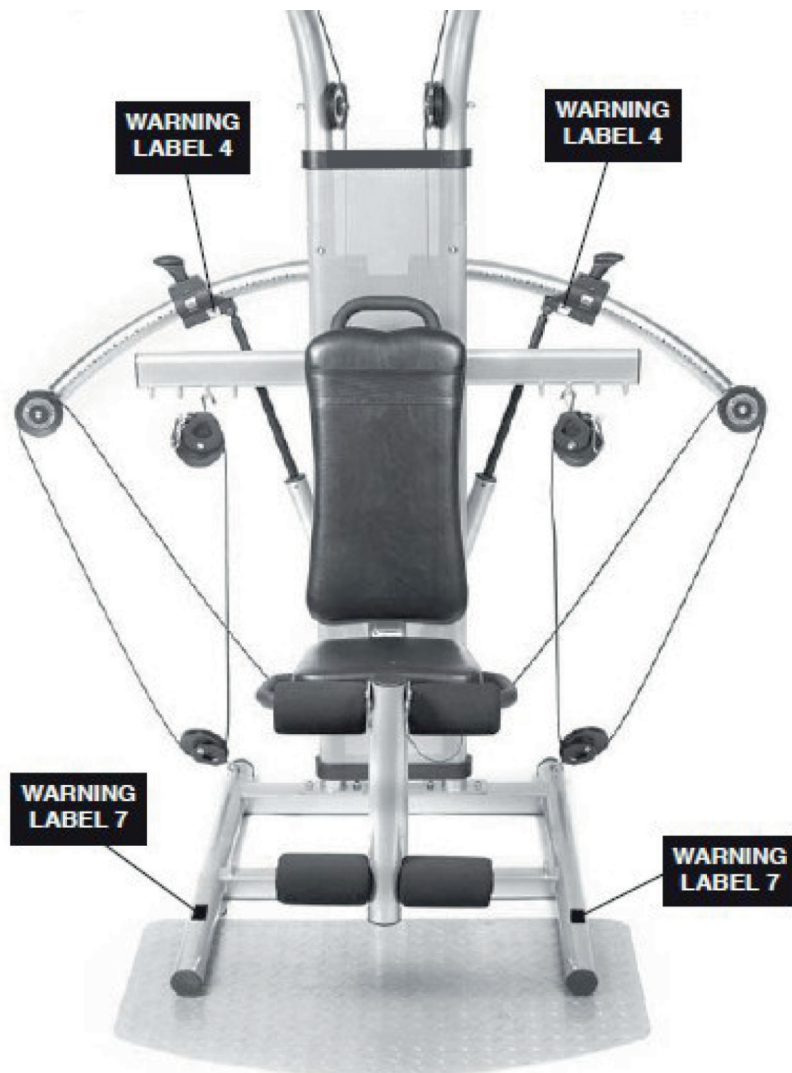

WARNING LABEL 4 (2 positions)

WARNING! Make sure that the pin is locked in the position before you begin the exercise.

WARNING LABEL 7 (2 positions)

WARNING! When you do exercises while standing, keep your feet on the ground plate.

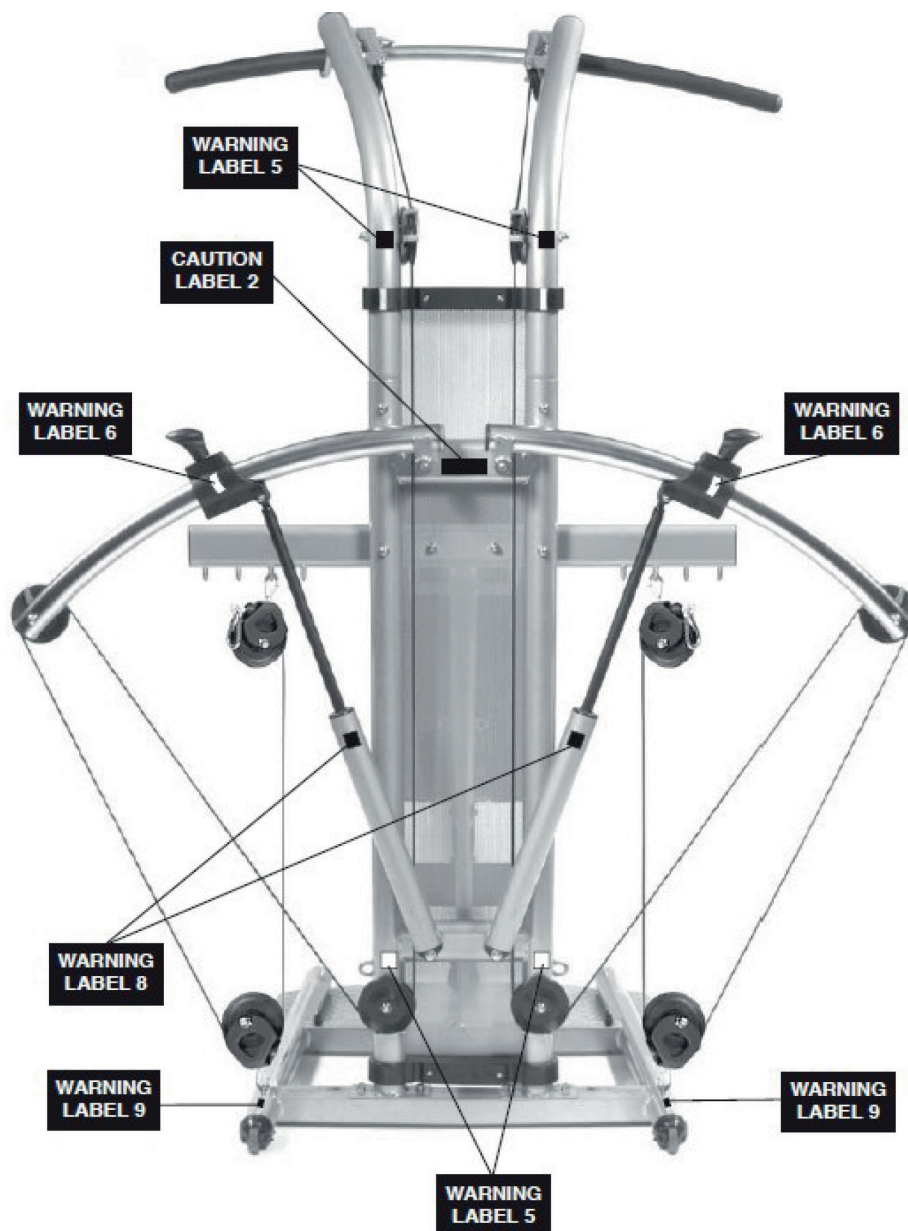

CAUTION LABEL 2

NOTE! In order to transport the equipment, we recommend doing this with two people.

WARNING LABEL 5 (6 positions)

WARNING! Do not touch the pulleys and mobile parts.

WARNING LABEL 6 (2 positions)

WARNING! Crushing hazard - only use adjusting arm with free hands.

WARNING LABEL 8 (2 positions)

WARNING! Content under pressure; DO NOT OPEN. Keep away from heat and fire.

WARNING LABEL 9 (2 positions)

WARNING! Do not remove pulley form this position after the equipment has been assembled.

2.5 Assembly

Before assembly, take a close look at the individual assembly steps shown and carry out the assembly in the order given.

① NOTICE

- + First loosely screw all parts together and check that they fit properly. Tighten the screws using the tool only when you are instructed to do so.
- + If you have difficulty recognising the graphics, we recommend that you open and/or download the PDF instructions stored in the webshop on your end device (e.g. smartphone, tablet or PC). There you have the option of zooming in closer. Please note that the Adobe Acrobat Reader programme must be installed on your end device in order to open the file.

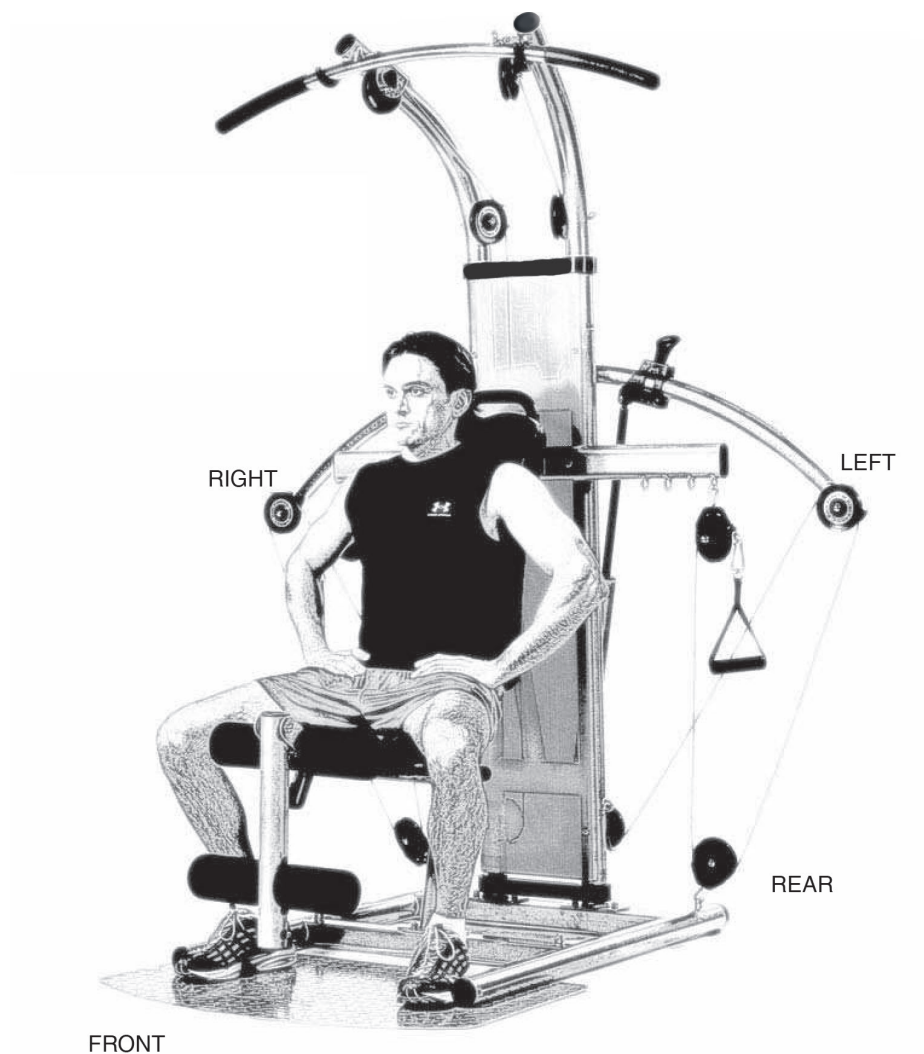

Required parts for step 1:

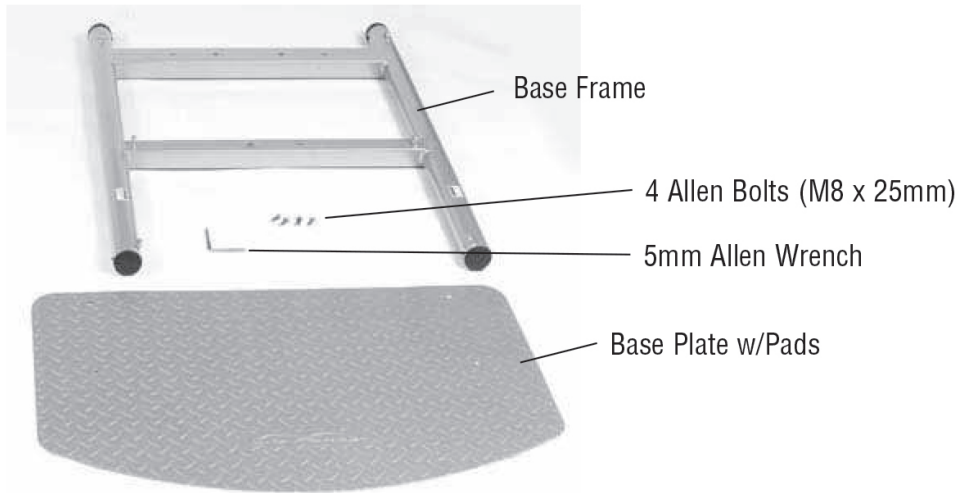

Step 1: Assembly base frame

1. Turn the main frame with the warning notes downward.
2. Position the ground plate on the main frame on the opposite side of the transport wheels and make sure that the bent side of the ground plate shows outward.
3. Align the holes in the ground plate with the main frame and attach the parts with the four screws.

Turn the assembled frame upwards (warning notes point upwards).

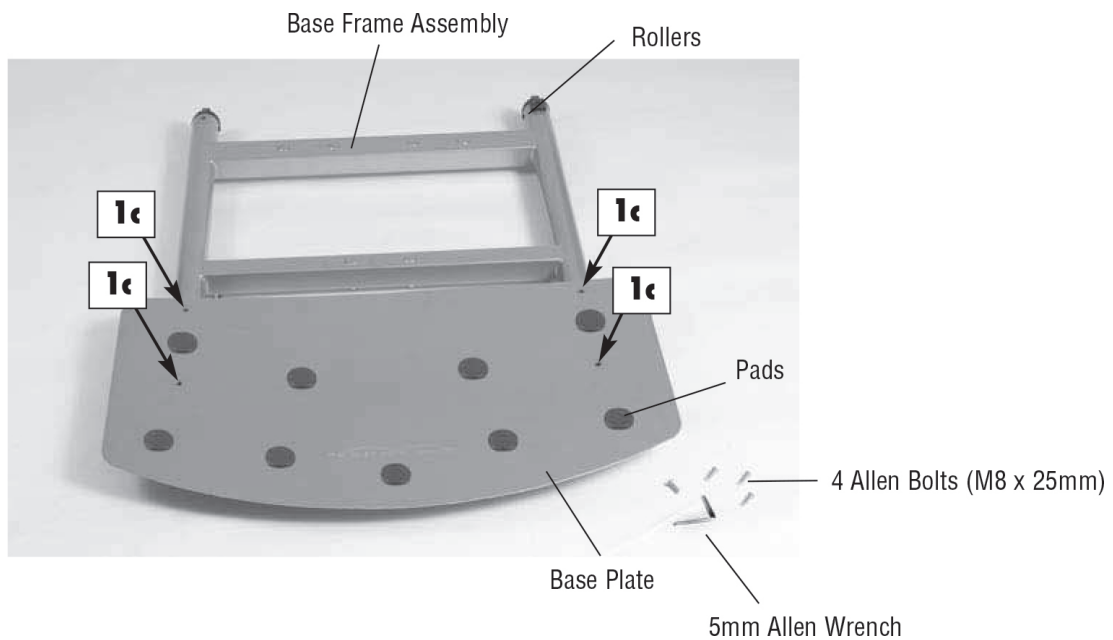

Required parts for step 2:

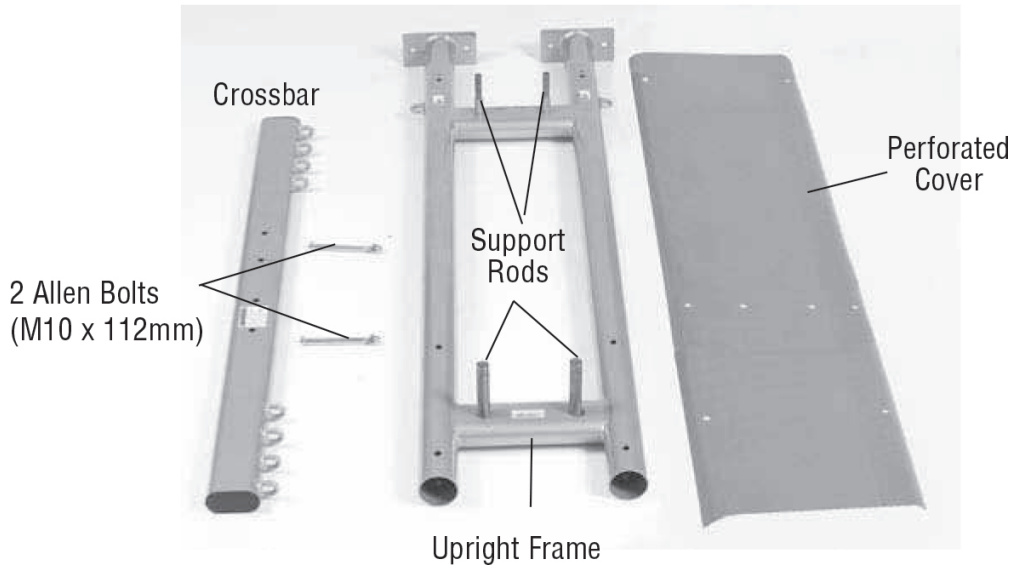

Step 2: Assembly of rear frame

1. Turn around the rear frame so that it is on the auxiliary strut and the warning notes point downwards.
2. Place the perforated cover and the crossbar on the frame and align the holes. The warning notes on the crossbar should point in your direction.
3. Attach the parts by placing the two screws through the exterior holes of the crossbar, the perforated cover and the frame and tighten with two nuts.

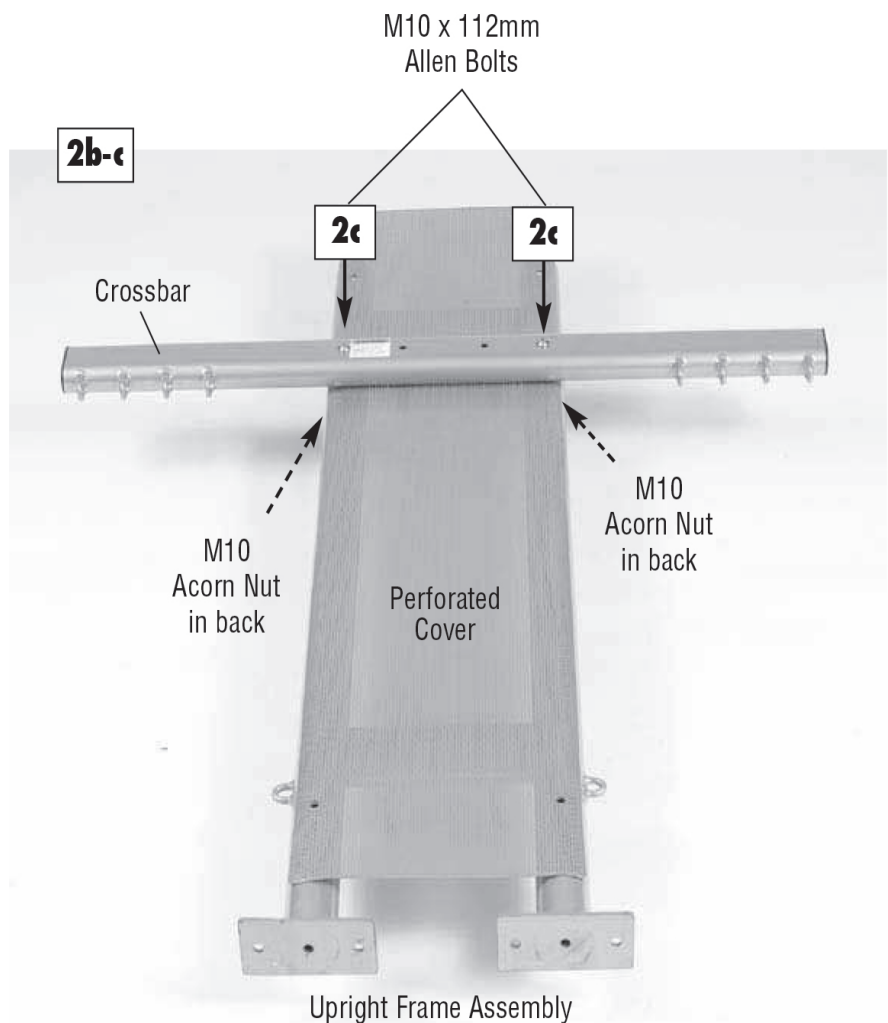

Required parts for step 4:

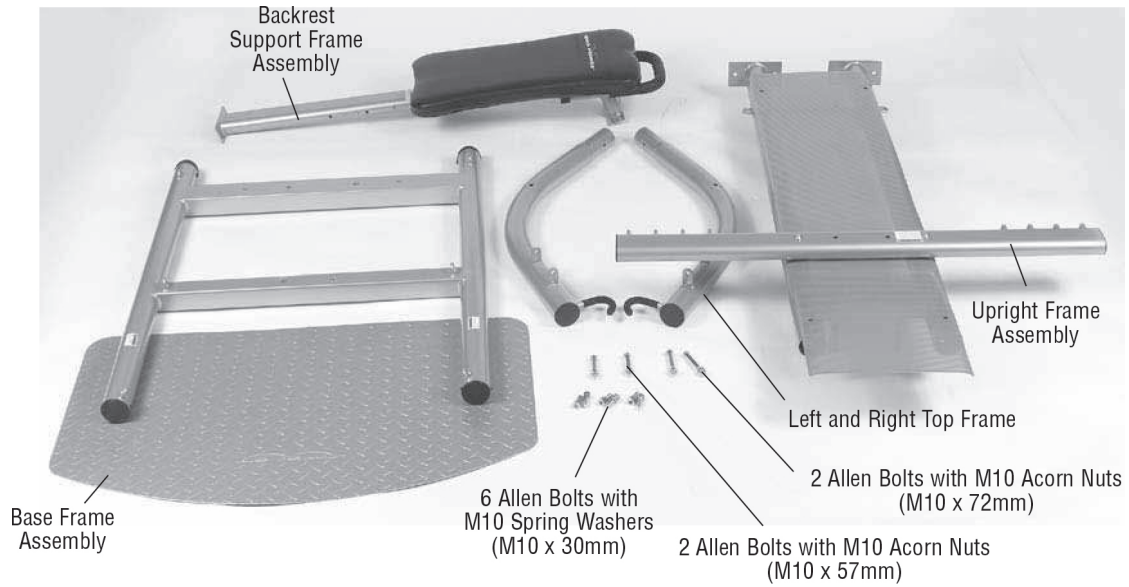

Step 4: Assembly frame components

1. Carefully straighten up the rear frame and place it on the rear traverse of the main frame. The crossbar and the perforated cover point forward. Mount the parts with four screws and spring washers and tighten these by hand.

► **ATTENTION:**

This step must be executed with two people.

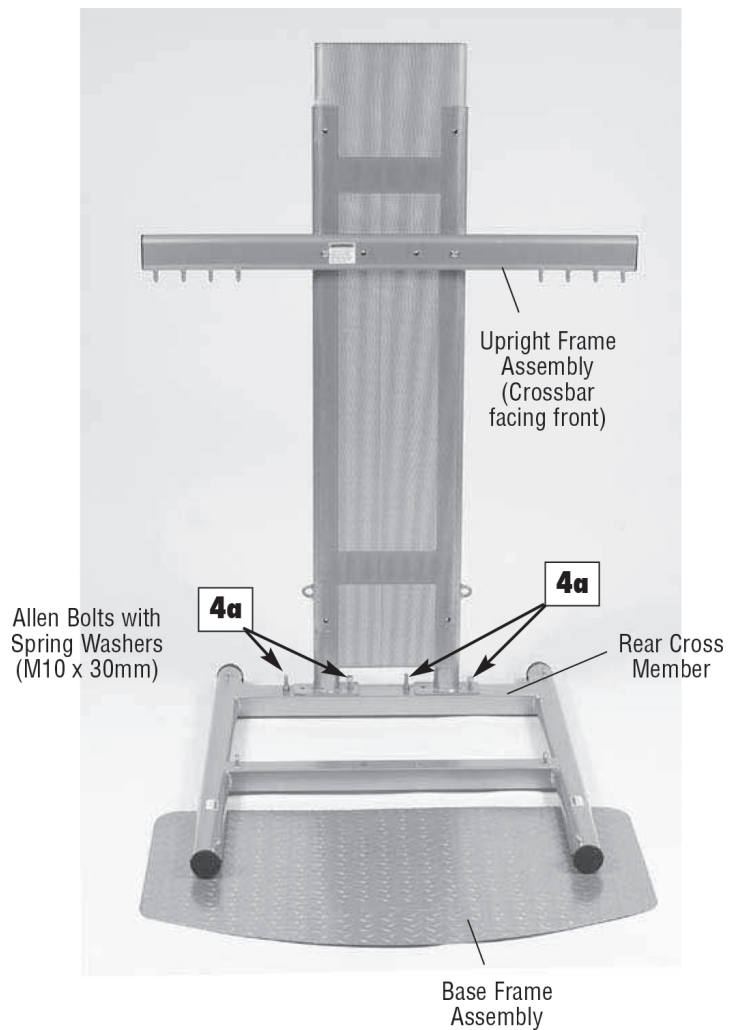

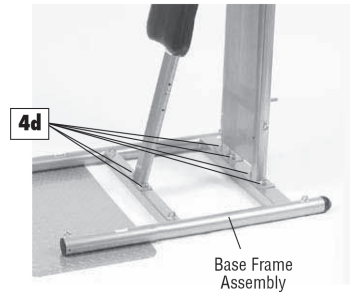
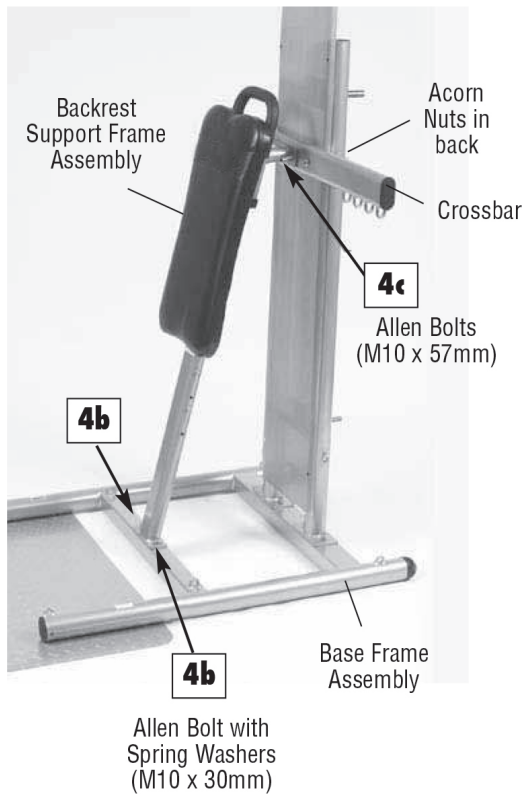

d. With the Allen Wrench, tighten the 6 Base Frame Bolts at this time.

2. Position the frame with the backrest by aligning the holes of the main frame with the holes of the frame with the backrest. Tighten the parts with two screws and spring washers.
3. Align the holes on the upper end of the backrest with the central holes in the crossbar. Mount the two Allen screws and two cap nuts and tighten these by hand.
4. Now tighten the six screws in the base frame with a wrench.
5. Slide the left and right upper frames into the upper end of the main frame, whereby the chrome pulley brackets point inward. Mount the parts with two Allen screws and cap nuts and tighten these by hand.

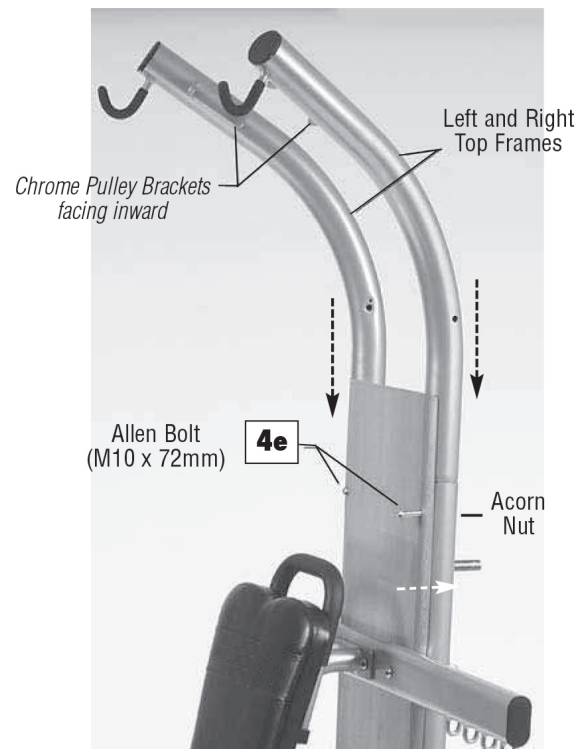

Required parts for step 5:

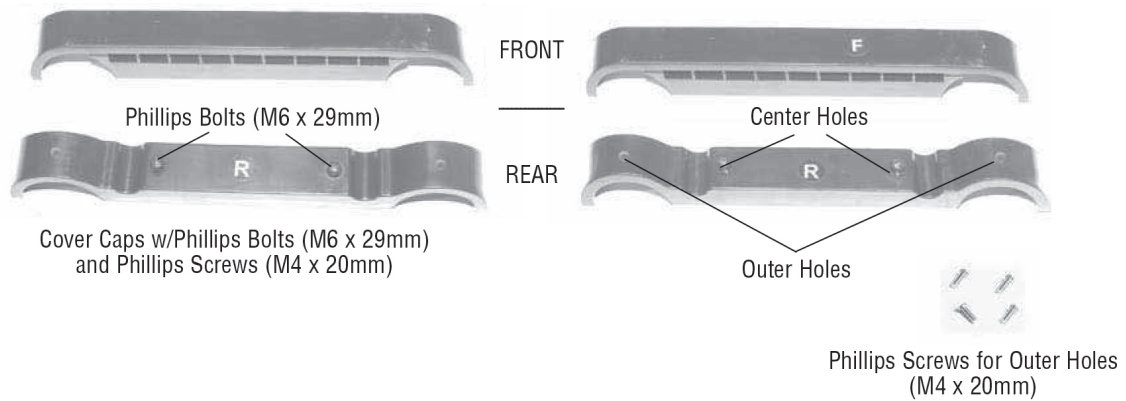

Step 5: Assembly covers

1. Remove the two (M6 x 29mm) hex head screws from the upper cover plates of the perforated metal plate with the Phillips wrench (included in delivery) and separate the front and back sides.

ⓘ NOTICE

The cover plate with the UltraForce logo belongs on the top on the front side.

2. Mount the front side of the upper cover plate by moving it onto the frame on the edge of the perforated metal plate. The cover plate may have to be pressed down slightly. Then mount the backside of the upper cover plate. Mount the two parts with the previously loosened hex head screws. Mount the backside of the upper cover on the frame with two hex head screws (M4 x 20mm) through the external drill holes. Tighten the screws with the Phillips wrench.
3. Repeat steps 1 and 2 for the lower cover plates.

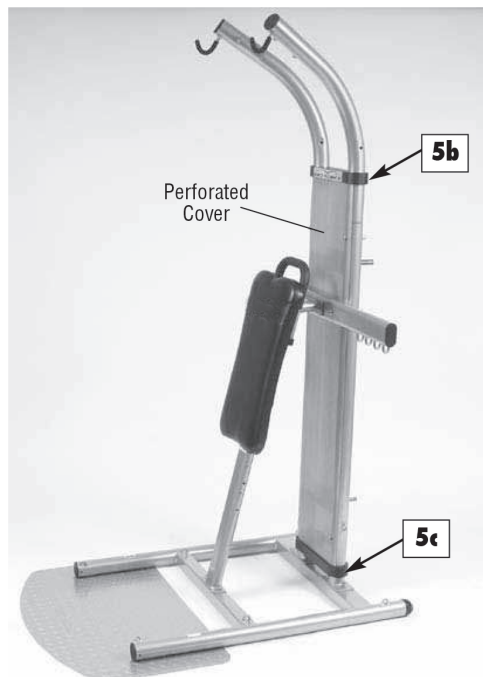

Required parts for steps 6 and 7:

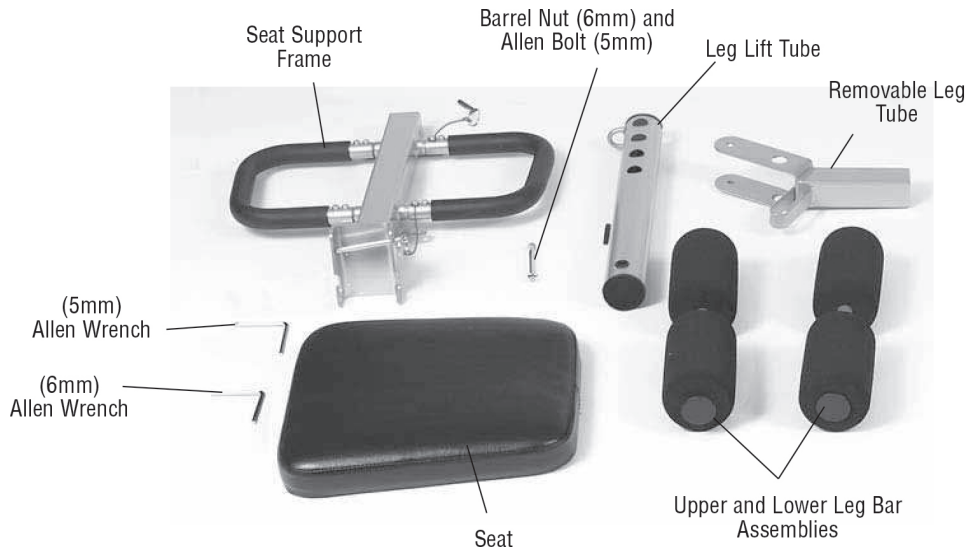

Step 6: Assembly of seat

1. Loosen the screws from the underside of the seat. Place the seat frame on the backside of the seat and make sure that the long socket pin and the bracket are in the same direction as the small end of the seat. Mount the parts with the four previously loosened Allen screws and the 5mm Allen wrench.
2. Remove the long socket pin from the seat frame. Hang the seat on the upper dowel pin from the backrest.

▶ ATTENTION

- + Make sure that the bracket on the seat frame is securely placed on the dowel pin.
 - + Secure the seat by sliding the long socket pin through the holes under the dowel pin.
3. Remove the short socket pin from the seat frame. Slide the removable leg extension unit in the seat frame as in the figure to the left. Secure the parts by sliding the short socket pin through the seat frame and the leg extension unit.

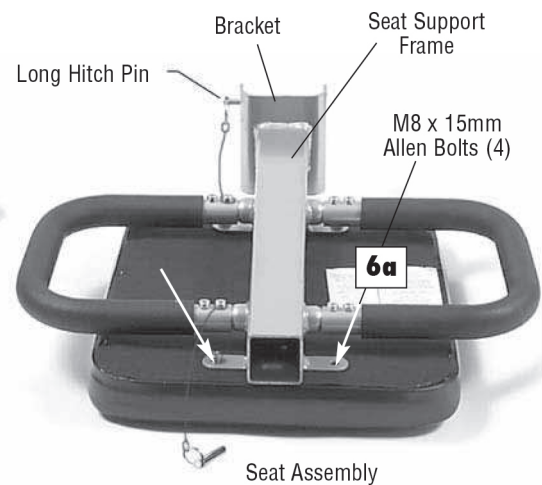
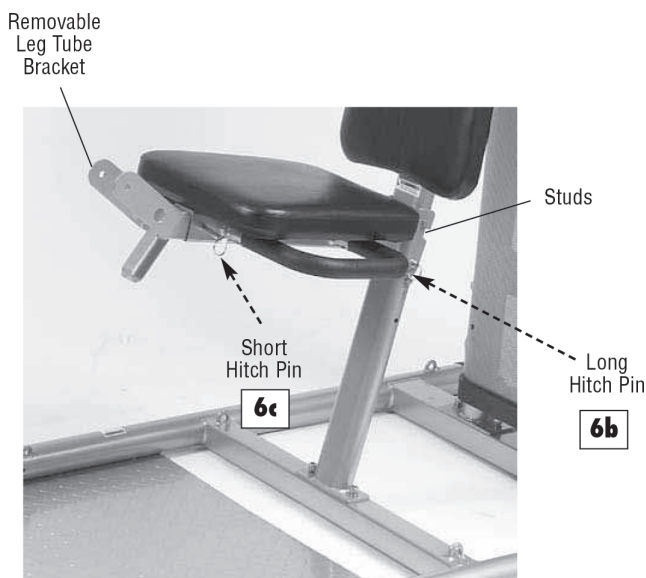

Step 7: Assembly of leg extension

1. Place the upper end of the leg extension tube on the bracket from the removable leg extension unit.

① NOTICE

The warning note points towards the seat. Slide the barrel nut through the removable leg extension unit and the leg extension tube. Mount the parts with the Allen screw and the Allen wrench (5&6mm).

2. Remove the cover cap and a foam cushion and slide the upper leg extension bar through the opening in the middle of the bracket of the removable leg extension unit. Slide the foam cushion and the cover cap back on to the leg extension bar.

▶ ATTENTION

Make sure that the cover cap is correctly placed on the bar.

① NOTICE

The upper leg extension bar is longer than the lower one.

3. Remove the cover cap and a foam cushion and slide the lower leg extension bar through the openings on the lower end of the leg extension tube. Slide the foam cushion and the cover cap back on to the leg extension bar.

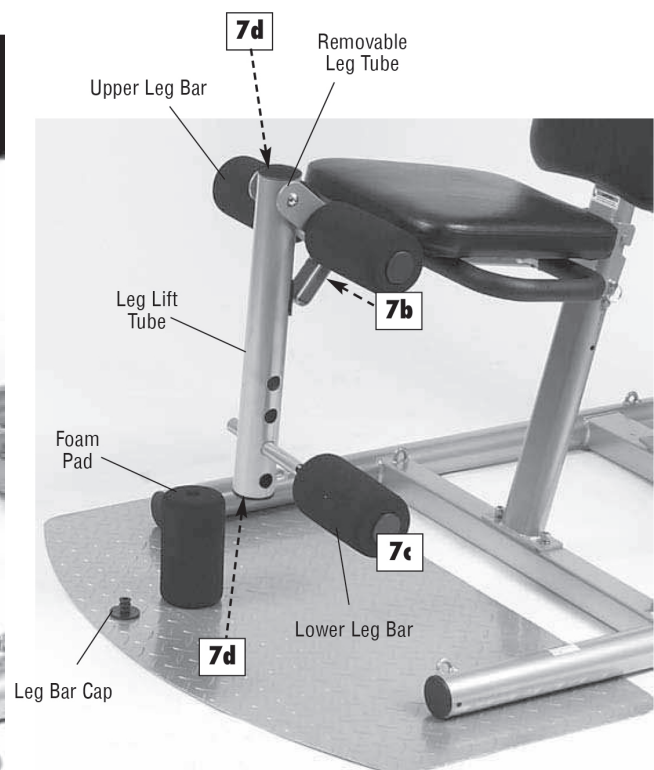

Required parts for step 8:

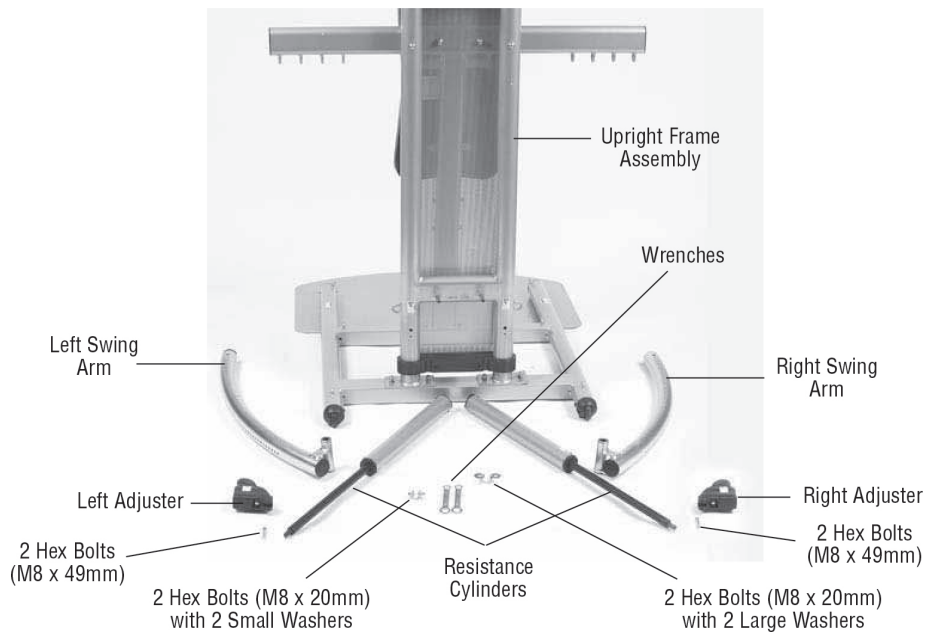

Step 8: Assembly swivel arms and cylinder

Place yourself behind the station.

1. Slide the right swivel arm on the supportive bar on the upper crossbar of the main frame. The label from the swivel arm points forward. Mount the right swivel arm with a large washer and a hex head screw.
2. Lift the knob from the right adjusting unit while you slide it to the swivel arm to number 20. The markings are located on the front side of the swivel arm. The adjusting unit is displayed to the right and left under the knob on the backside. The markings for setting the weight must be visible through the opening on the front side of the adjusting unit.
3. Place the lower end of the resistance cylinder on the supporting bar of the lower crossbar from the main frame. Place the upper end of the cylinder to the outer right. Mount the lower end of the cylinder with a small washer and a hexagon screw.

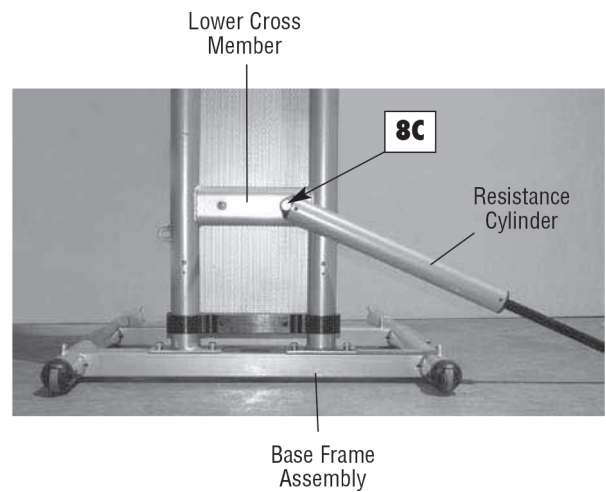
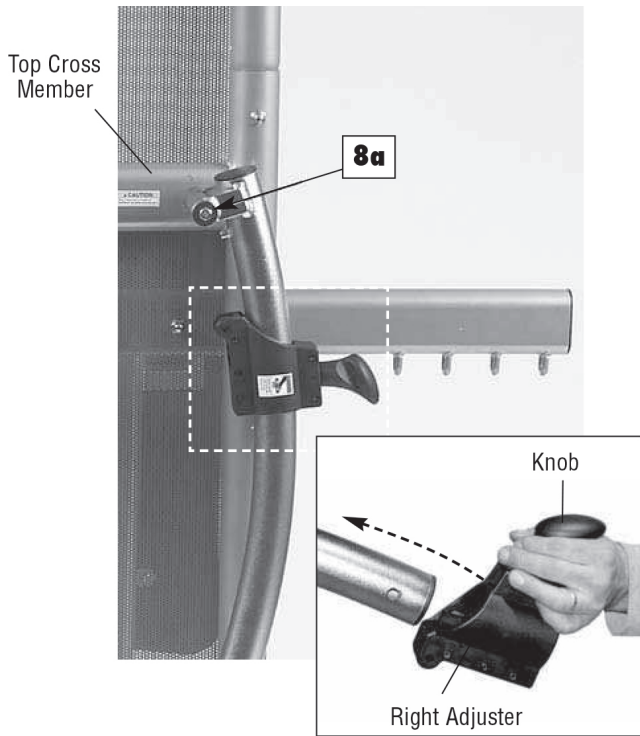

NOTICE

All nuts and screws are brought in from the front to back - with the nut on the backside.

4. Lift the right swivel arm and the resistance cylinder. Mount the upper end of the cylinder with the lower part of the right adjusting unit with a cap nut and a hex head screw. The nut is located on the backside here.
5. Repeat steps 1 to 4 for the left side.

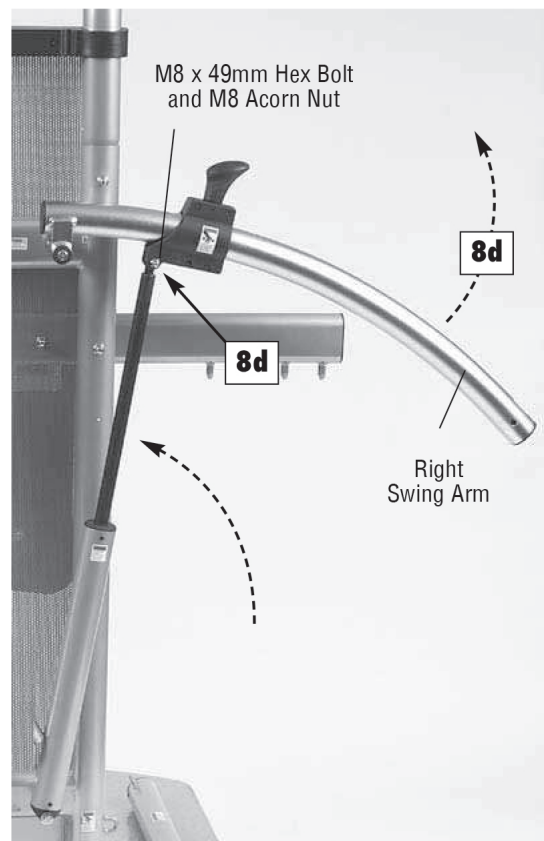

Required parts for step 9:

6 Pulley Brackets
(marked by their
position on the unit)

6 Pulleys

6 Allen Bolts
(M10 x 95mm)

6 Acorn Nuts (M10)



Step 9: Assembly pulleys

1. Determine the positions of the individual pulley holders, see markings.
2. Take the two pulleys without the UltraForce logo and the two pulley brackets, which are designated for the lower end of the main frame. Mount the pulleys on the lower backside of the main frame with two Allen screws and two cap nuts. Do not tighten the screws yet!
3. Take the two pulley brackets for the upper end of the main frame and the two pulleys with UltraForce logos. Mount these parts on the upper main frame with two Allen screws and two cap nuts. The logos are facing each other.
4. Take the two pulley brackets for the swivel arms and the two pulleys with UltraForce logos. Mount these parts on the end of the swivel arms with two Allen screws and two cap nuts. The logos point forward.

Notes for steps 9-2 to 9-4:

- + **All nuts and screws are brought in from the front to back - with the nut on the backside.**
- + **Make sure that the bracket pins are properly anchored.**
- + **The nuts must first be tightened slightly in order to attach the rope.**

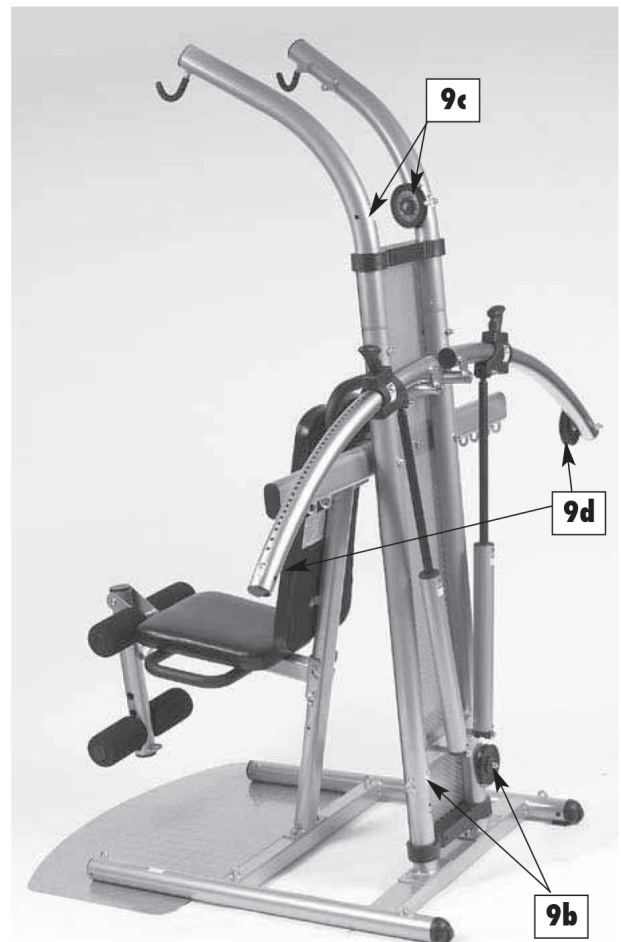
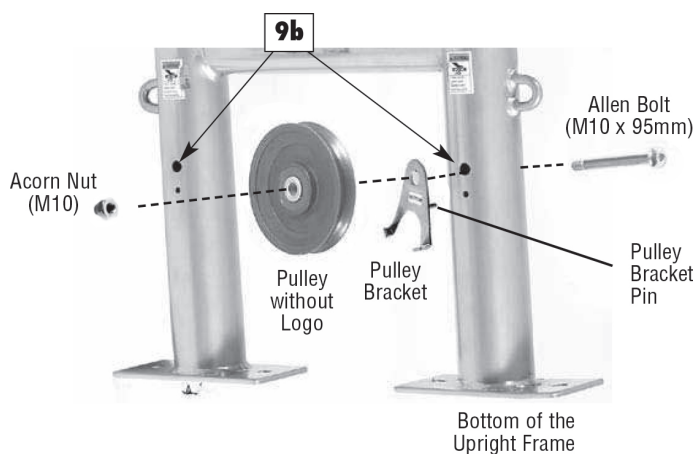

Required parts for step 10:

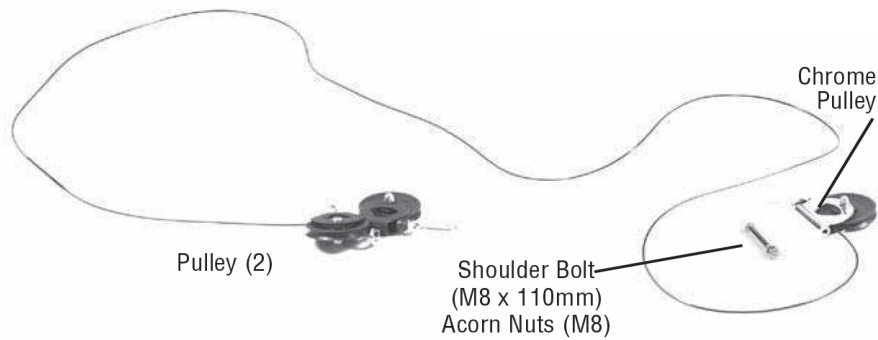

Step 10: Assembly of the cable

1. Lay out and unwind cable. Slide the chrome pulley to one end of the cable. Slide the other two pulleys to the other end of the cable. This keeps the cable unwind during installation.
2. Mount the chrome pulley with bracket on the upper right frame with a thread screw and a cap nut, see image. The large snap hook must be in front and the nut in the back. You must be able to spin the pulley. Note: You may need a ladder for this step.
3. Moving the cable.

ⓘ NOTICE

If you attach the cable to previously assembled pulleys, it may be easier if you loosen the nuts and pull out the pulley. After you have guided through the cable, mount the pulley and the bracket again before you continue.

- a. Guide the cable downward through the pulley above the perforated sheet.
 - b. Guide the cable from the outside passing the upper and lower supporting bars and then inside to the lower pulley.
 - c. Guide the cable upward around the pulley to the inner side of the pulley on the swivel arm.
 - d. Guide the cable downward through the pulley on the swivel arm to the hook on the rear side of the main frame.
Hook the pulley on the cable set on the hook on the rear end of the base frame by loosening the Phillips screw until the hook can be mounted on the pulley on the hook from the main frame. Tighten the Phillips screw so that the pulley can not loosen from the hook.
4. Repeat steps 1-3 for the left side.
 5. Now tighten all screws and nuts. Make sure that the cable does not get stuck.

▶ ATTENTION

Now tighten all screws and nuts that were only slightly tightened in the previous steps. The corresponding screws are marked in the figure with a black dot.

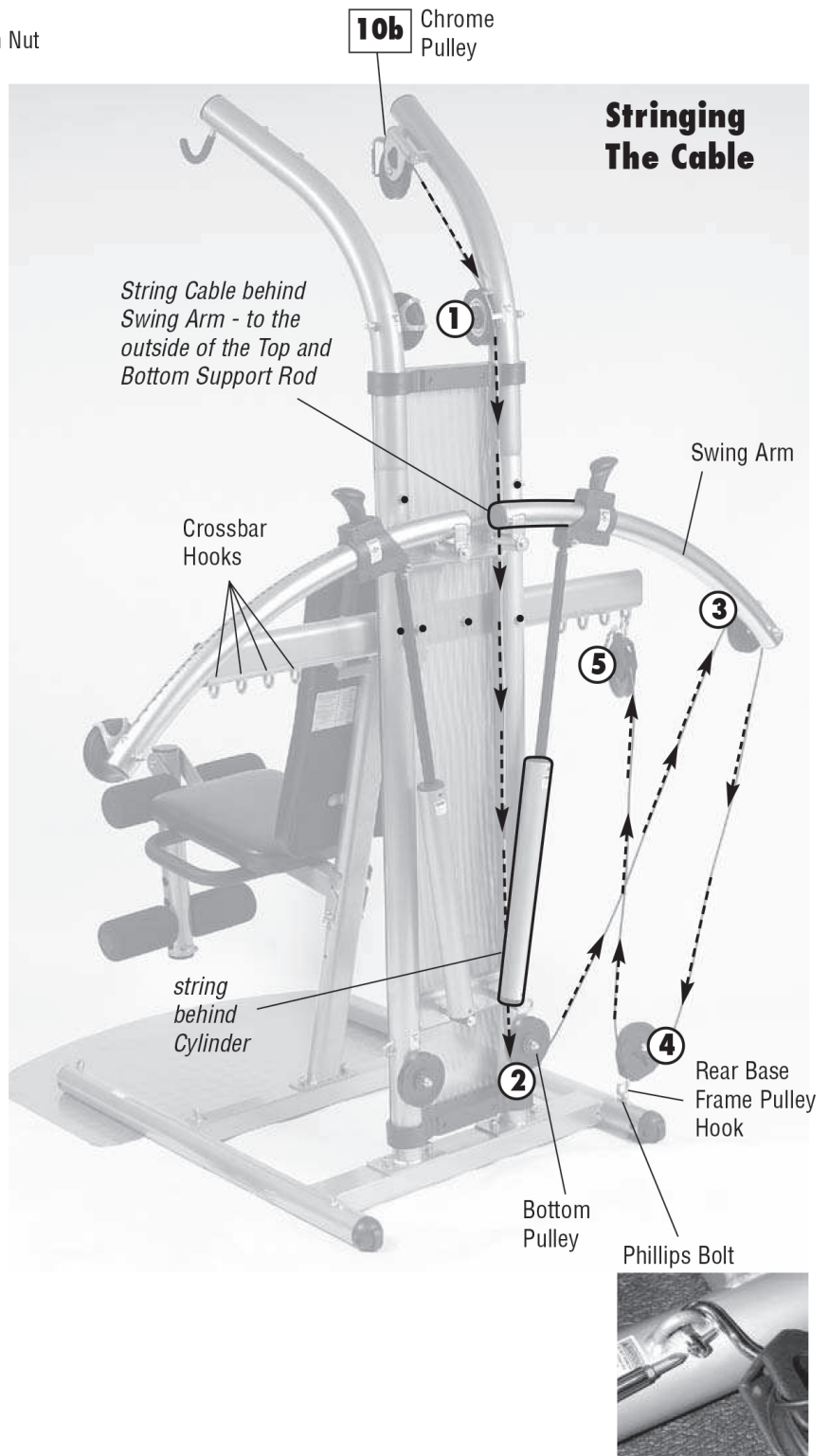
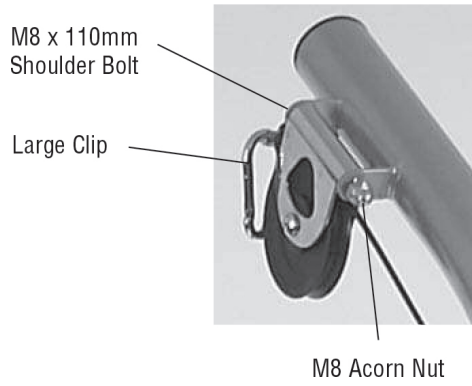

Step 11:

1. Mount the lat bar on the large snap hook on the upper frame. Then place the lat bar in the designated hook on the upper frame.
2. Mount the handles with the large snap hook on the end of the cable on the crossbar.

NOTICE

The foot loops can now be suspended on the hook from the leg extension unit.

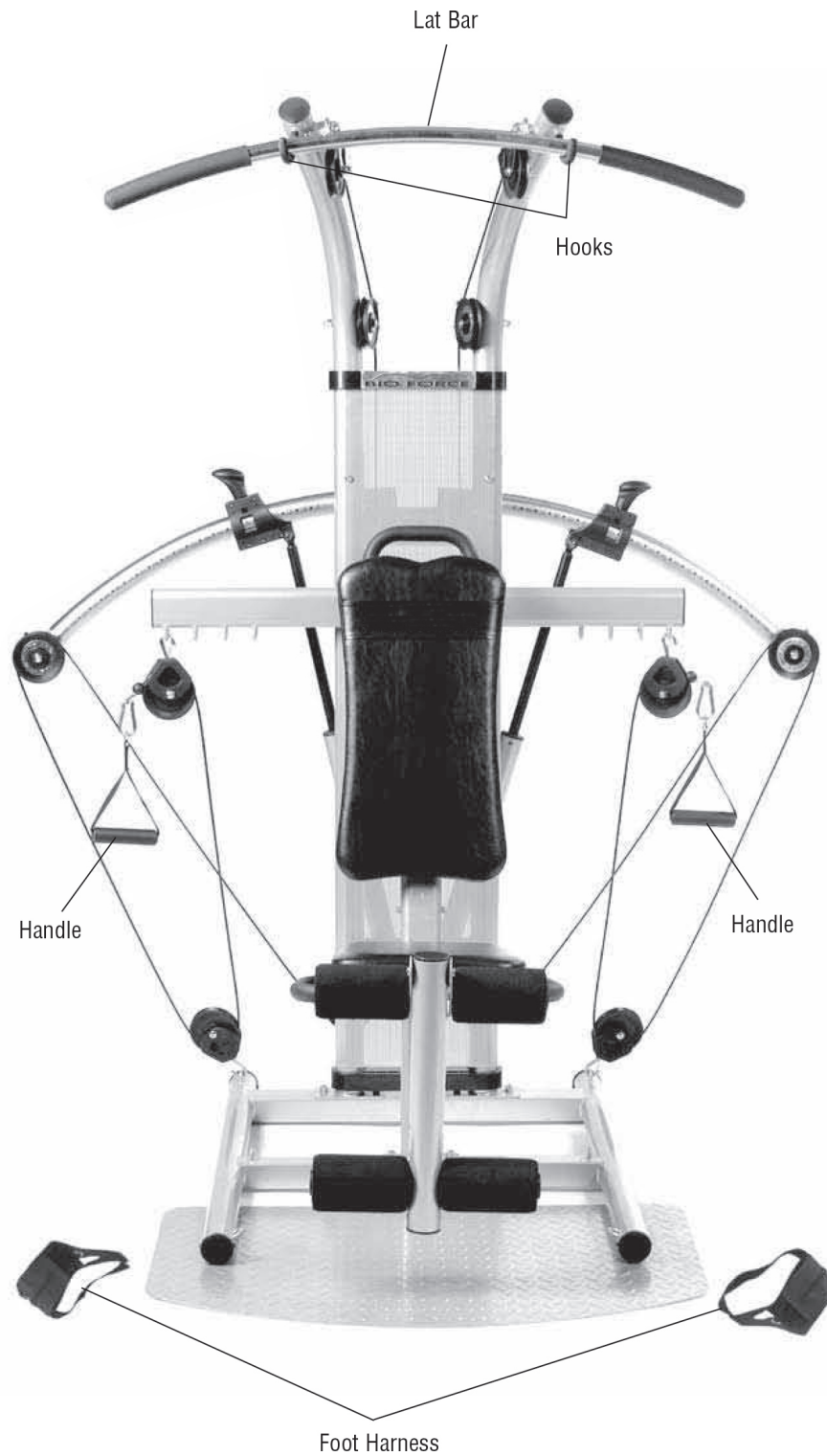

3.1 General Instructions

WARNING

- + The storage location should be chosen so that improper use by third parties or children can be prevented.
- + If your equipment does not have transportation wheels, the equipment must be disassembled before transportation.

▶ ATTENTION

- + Make sure that the equipment is protected from moisture, dust and dirt in the selected storage location. The storage location should be dry and well ventilated and have a constant ambient temperature between 10°C and 35°C.

3.2 Transportation Wheels

▶ ATTENTION

If you want to transport your equipment over particularly sensitive and soft floor coverings, such as parquet, planks or laminate, lay out the transport route with cardboard or similar to avoid possible floor damage.

1. Stand behind the equipment and lift it until the weight is transferred to the transportation wheels. After that, you easily can move the equipment to a new position. For long transport distances the equipment should be disassembled and safely packed.
2. Select the new location by following the instructions in the section 1.3 of this manual.



figure 1



figure 2

The Taurus UltraForce is a multi-functional multi-gym for achieving many training targets. Muscle toning and tightening are possible as well as an improvement of strength-endurance and an effective support in losing weight. We have compiled some important training tips for you so you can achieve your training targets as effectively, safely and lastingly as possible.

4.1 General training instructions

► ATTENTION

- + Please read through this section before you begin training.
- + If you are older than 35 years and have not trained for several years, consult your physician and they will recommend an assessment test. Your physician can support you in determining the target heart rate zone corresponding to your age and fitness level as well.

You should also consult your physician in the event of:

- + High blood pressure
- + High cholesterol values
- + Asthma
- + Heart problems
- + (Death through) strokes or heart attacks in your family history
- + Frequent cases of dizziness
- + Extreme breathing problems after slight strain
- + Arthritis or other bone problems
- + Serious muscle/ligament/or tendon problems
- + Other known or presumed illnesses
- + If you feel pain or tension in the breast, feel an irregular heart beat or are short of breath, stop training immediately. Consult your physician before you continue.
- + Pregnancy
- + Balance impairments
- + Taking medicine that affects your heart rate.

Warm-up

We recommend starting every training session by warming up in order to prevent injuries and to maximize performance. Your warm-up phase prepares your muscles softly for the load. Begin with five to 10 minutes of soft exercises (e. g., walking) that gradually increase your heart rate and loosen up your muscles. The warm-up phase should be aerobic and require a slight, unconstrained range of movement. This should be followed by five to 10 minutes of stretching (see page 38 in these instructions or in the included training instructions). Never bring your body beyond the point of soft tension or strain. Make sure to have soft, rhythmic, controlled movements.

Clothing

All training clothing should sit loosely and comfortably (for enough freedom of movement) and give self-confidence. Never wear rubber and synthetic clothing; such materials impair the evaporation of sweat and may cause a dangerous increase in body temperature. Wear comfortable, supportive sport shoes with anti-slip soles like running or aerobic shoes.

Motivation tips

1. Create a plan and write it down.
2. Set realistic goals and remind yourself of them often.
3. Keep a journal in order to record your progress and update it regularly. See tables in these instructions.
4. Write down your weight and/or body fat percentage measurements in the journal.
5. Get support and participation from family and friends.
6. Keep other people up to date about your success.
7. Avoid injuries through adjustments including warm up and cool down phases as a part of your daily workout.
8. Reward yourself in regular intervals for a job well done!

4.2 Exercise and safety notes

1. Carefully and completely go through these user instructions and the included training instructions before you start a training program. Remember to follow the instructions exactly. These were developed with your health and safety in mind.

2. Execute all exercises in a slow and controlled manner. Execute all exercises at the speed specified in the training instructions in order to achieve the best results. Training at a high pace is not recommended and may impair your safety and results.

3. You may not be able to completely finish all sets and repetitions at first. If you feel fatigue in your muscles or if you cannot train in a good condition and with the corresponding techniques, lower the resistance level or take a short break and cool down.

4. Record the number of sets and repetitions that you can initially do for each exercise. You will be surprised how fast you can make progress. Within a few weeks, it will be possible for you to execute all sets and repetitions at your selected resistance level.

5. Take it slow. If you are tired and emaciated after training, you are training at a level that is too high. You can achieve good results with training that challenges you, but does not cause pain or excessive tiredness.

6. Make sure you know how to execute safe and appropriate training. These safety measures are for your benefit and you should follow them exactly in order to maximize the effectiveness of your training routine.

7. You will feel the results of your training with this equipment within one to two weeks. Pay attention to a better posture and you will find more power and effectiveness in your muscles.

4.3 Exercise manual

A detailed description of all exercises can be found in the included training instructions.

4.4 Equipment settings

Set resistance with glide-n-lock technology

The resistance setting is done quickly. Simply pull up the glide-n-lock slider to unlock it from its current position. Hold the slider up and move it into the desired weight setting and then let go of the slider. Make sure that the locking mechanism has locked in the new resistance position. Make sure that the resistance indicator is red.

Seat adjustment

The UltraForce seat allows for two sitting heights. If you are tall, you may prefer the lower position in order to reach the complete range of movement of the exercises with the lat tower. If you are smaller, you may prefer the higher position in order to be able to grab the lat bar easier. You can choose. If you would like to change the position, remove the long socket pin and pull the seat up in order to unlock it from the position pins. Set it to the new position and place the seat back on the position pins. As soon as it is at the desired position, insert the long socket pin again to lock it.

► ATTENTION

Do not use the seat if the long socket pin is not inserted.

Adjust leg piece

The lower foam upholstery on the leg extension tube has four positions. These are adjusted to the user's leg length and comfort.

In order to change the foam upholstery, simply remove the leg bar cap at the end of the upholstery. Remove the foam cushion on the side. Now push the tube and remaining upholstery from the leg assembly hole. Set it to the new desired position. Attach the leg bar cap and the first foam upholstery again. Make sure that the leg bar cap is installed securely again.

UltraForce positions of the pulleys

The UltraForce equipment uses a simple system of cables, pulleys and hooks in order to be able to execute over 100 exercises. Below you can see a diagram that shows you the possibilities for the mobile positions of the pulleys and accessory hooks.

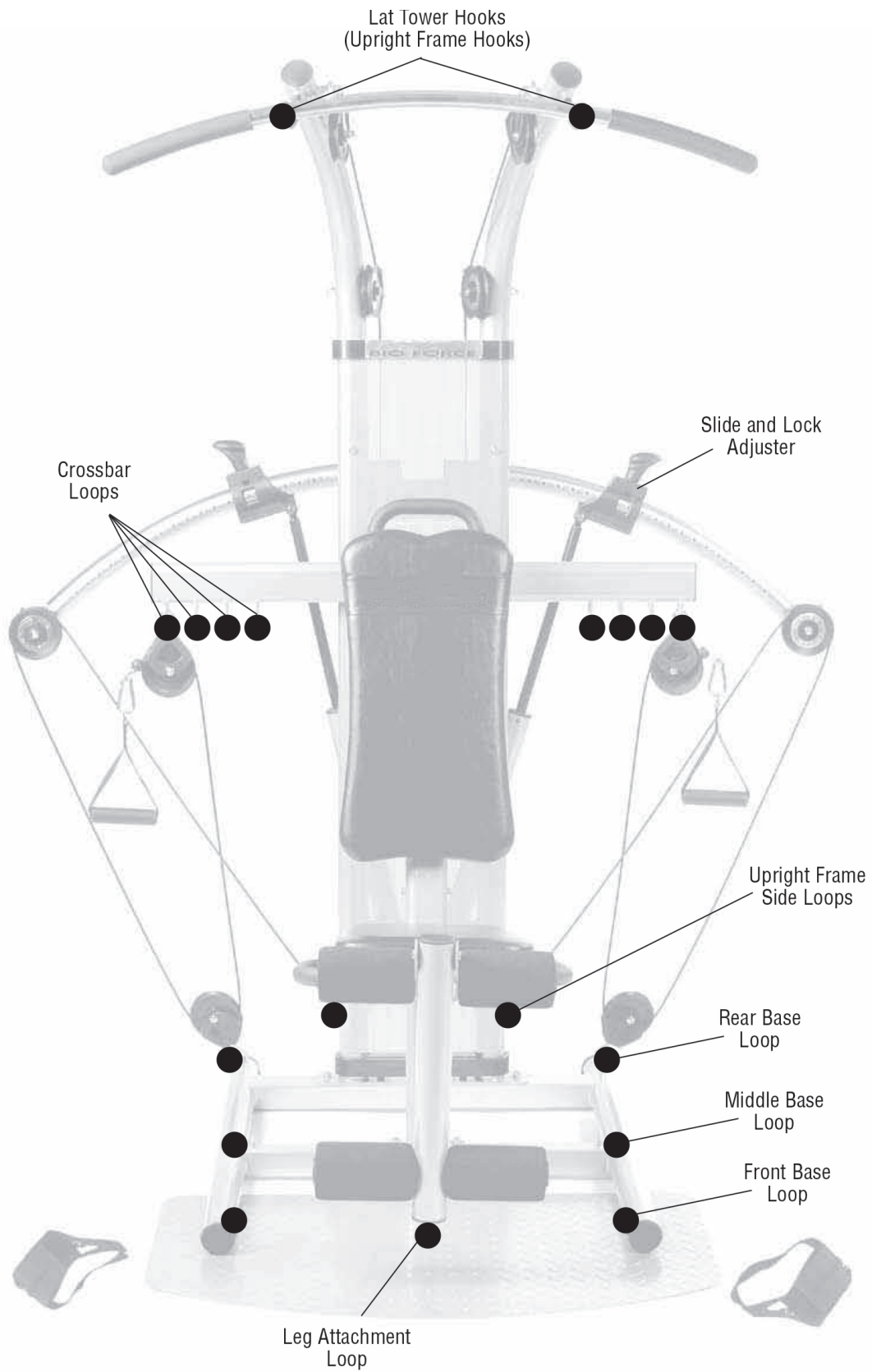

4.5 Stretching exercises for leg & chest muscles

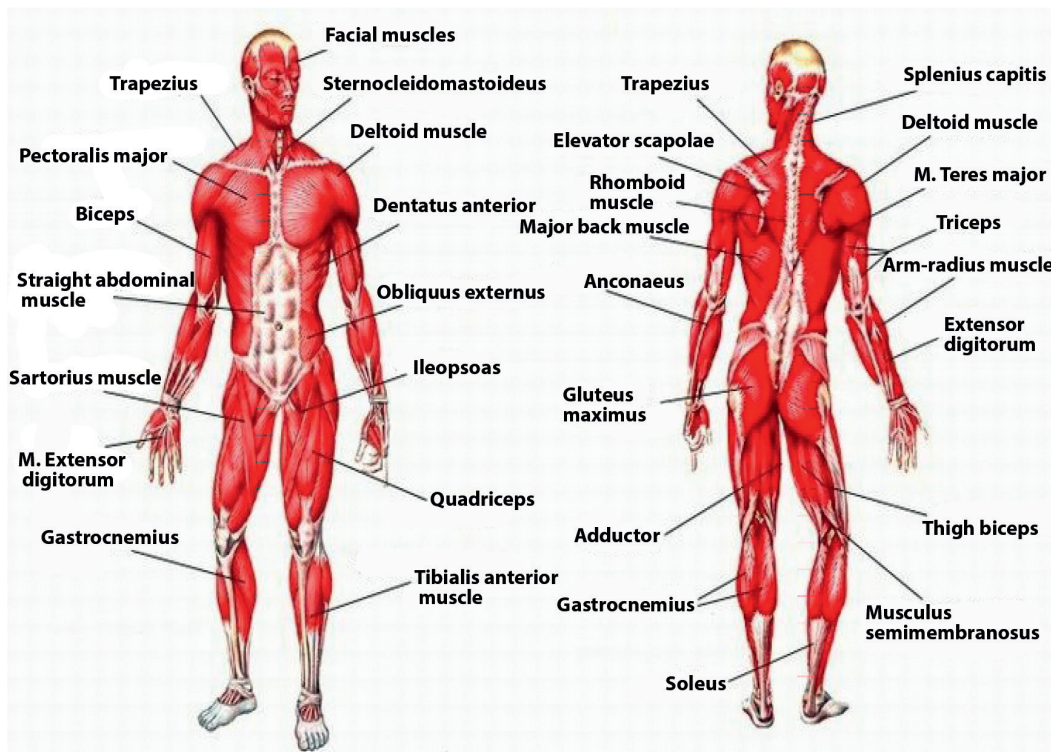

1. Exercise: Stretching of front thigh / leg extension (quadriceps)

- + Stable position, grab arches of feet
- + Pull heel towards buttocks, knee points downwards (no abduction)
- + Straight upper body, avoid tilting the pelvic forward (hollow back) by tensing the abdominal muscles
- + Change legs

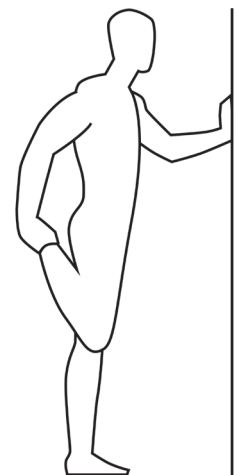

2. Exercise: Stretching the back thigh / leg curl (hamstring)

- + Pull thigh towards upper body with both hands
- + Stretch through increased stretching in the knee joint
- + The lower leg maintains contact with the floor, keep hips bent
- + Change legs

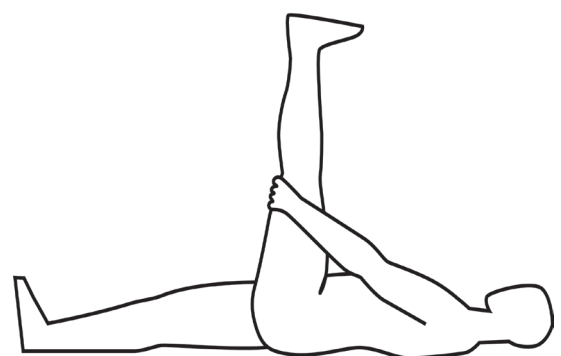

3. Exercise: Stretching the calf muscles (gastrocnemius)

- + Place feet parallel to each other pointing forward, the heels touch the floor
- + Support yourself on a chair coming from a lunge
- + Move your body weight to the front leg, press your heel from the rear leg towards the floor and hold the contact
- + Slowly stretch your knee of the rear leg until you feel the stretch in your calves
- + Change legs

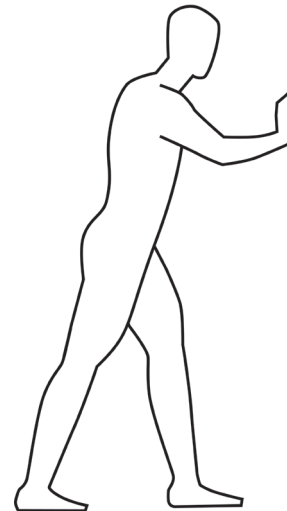

4. Exercise: Stretching the chest muscles (pectoralis major)

- + Stand parallel to a wall
- + Place your forearm at 90° to the wall with the elbow just above shoulder height
- + Turn your head and upper body gradually to the opposite sides until you feel a stretch in the front chest, of the shoulder being leaned on
- + Pay attention to tension in your abdominal and gluteal muscles
- + Your weight is on your front leg
- + Change legs

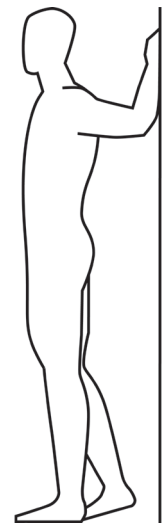

All recommendations of these instructions apply solely to healthy people and are not suitable for those with heart or cardiovascular problems. All of the tips are intended only as a guide to help you create a workout. Your physician can offer appropriate advice for particular, personal requirements.

We hope you enjoy your workout and have a lot of success!

5.1 General Instructions



WARNING

- + Do not make any improper changes to the equipment.



CAUTION

- + Damaged or worn components may affect your safety and the life of the equipment. Therefore, immediately replace damaged or worn components. In such a case, contact the contract partner. The equipment must not be used until it has been repaired. If necessary, use only original spare parts.



ATTENTION

- + In addition to the instructions and recommendations for maintenance and care given here, additional service and/or repair work may be necessary; this must only be carried out by authorised service technicians.

5.2 Faults and Fault Diagnosis

The equipment undergoes regular quality controls during production. Nevertheless, faults or malfunctions may occur. Frequently, individual parts are responsible for these disturbances, an exchange is usually sufficient. Please refer to the following overview for the most common errors and how to correct them. If the equipment still does not function properly, contact your contract partner.

Fault	Cause	Solution
Grinding noises	Cables or pulleys do not run smoothly or are damaged	+ Visual inspection of the cable routing or the pulley guide + If damaged, replace the defective part
No resistance	Defective cylinder	Check the cylinder for resistance
Squeaking & cracking noises	Screw connections loosened or too tight	Check screw connections

5.3 Maintenance and Inspection Calendar

To avoid damage from body sweat, the equipment must be cleaned with a damp towel (no solvents!) after each training session.

The following routine tasks must be performed at the specified intervals:

Part	Weekly	Monthly	Quarterly
Screw connections		I	
Pulleys and cable routing		I	
Wheels and rope guide		I	
Legend: C = clean; I = inspect			

6 DISPOSAL

At the end of its operational life, this equipment cannot be disposed of in normal household waste. Instead, it must be disposed of via an recycling centre. Further information can be obtained from your local authority's recycling service.



The materials can be recycled as per their symbols. Through the reuse, recycling of materials or other forms of recovery of old equipment, you make an important contribution to the protection of the environment.

7 RECOMMENDED ACCESSORIES

To make your training experience even more efficient and pleasant, we recommend that you add suiting accessories to your fitness equipment. For training equipment like smith machines, weight benches or racks this could for example be a **floor mat**, which makes your fitness equipment stand more securely and also protects the floor from sweat but it could be also **additional weights, handles, foot straps** for leg exercises or **triceps ropes**. For some smith machines, there are also optional add-ons such as **leg presses** that make your workout even more intense and comprehensive.

Our range of accessories offers the highest quality and makes training even better. If you would like to find out more about compatible accessories, please go to the detail page of the product in our webshop (the easiest way is to enter the article number in the search field above) and go to the recommended accessories on this page. Alternatively, you can use the QR code provided. Of course, you can also contact our customer service: by telephone, e-mail, in one of our branches or via our social media channels. We will be happy to advise you!



floor mat



chest strap



triceps rope



weight block extension

8.1 Serial Number and Model Name

In order to provide you with the best possible service, please have the model name, article number, serial number, exploded drawing and parts list ready. The corresponding contact options can be found in chapter 10 of this operating manual.

NOTICE

The serial number of your equipment is unique. It's located on a white sticker.

Enter the serial number in the appropriate field.

Serial number:

Brand / Category:

Model Name:

Article Number:

8.2 Parts List

No.	Name	Qty.
1	UPRIGHT FRAME	1
2	PULLEY WHEEL WITH LOGO PLATE	4
3	TAPPING SCREW q;2x4mm	12
4	PULLEY WHEEL	8
5	REARING	12
6	PLASTIC PULLEY COVER	12
7	OIL BEARING	24
8	BOTTOM PULLEY BRACKET	2
9	PERFORATED COVER	1
10A	FRONT TOP COVER CAP	1
10B	FRONT BOTTOM COVER CAP	1
11	REAR COVER CAP	2
12	ALUMINIUM LOGO PLATE	1
13	M4X10 PHILLIPS BOLT (TAPPING SCREW q;3.5x10mm)	12
14	M60 ROUND TUBE CAP	6
15	PHILLIPS BOLT M6x29mm	4
16	BACKREST SUPPORT FRAME	1
17	CROSS BAR	1
18	BACKREST HANDLEBAR	1
19	FOAM GRIP q;31.4xq;25.4x450	1
20	ALLEN BOLT M8x40mm	2
21	1" SQUARE TUBE CAP	2
22	OVAL END CAP	2
23	RUBBER PADDER-PULLEY SHROUD	4
24	BOLT M10x47mm(THREAD LENGTH 12mm)	4
25	ACORN NUT M10	20
26	BASE FRAME	1
27	BASE PLATE	1
28	BASE PLATE PAD	3
29	ROLLER	2
30	PLASTIC ROLLER CAP(L)	1

31	PLASTIC ROLLER CAP(R)	1
32	ALLEN BOLT M8x46mm(THREAD LENGTH 10mm)	2
33	PHILLIPS SCREW M6x20mm	1
34	BASE FRAME PAD	2
35	PHILLIPS SCREW M4X20mm (TAPPING SCREW q;4x20mm)	6
36	TOP FRAME TUBE (L)	1
37	PULLEY WHEEL(A) WITH LOGO PLATE	4
38	CHROME PULLEY ASSEMBLY	2
39	ALLEN BOLT M10x38mm(THREAD LENGTH 10mm)	2
40	TOP FRAME TUBE (R)	1
41	TOP PULLEY WHEEL BRACKET (L)	1
42	FOAM GRIP <t14x<t12x125	2
43	SWING ARM ASSEMBLY BRACKET (L)	1
44	OIL BEARING	4
45L	CALIBRATION STICKER(L)	1
45R	CALIBRATION STICKER(R)	1
46	TUBE CAPq;50.8mm	4
47	LEFT ADJUST SHROUD (LF)	1
48	LEFT ADJUST SHTOUD (LR)	1
49	ADJUSTER PLASTIC WHEEL	12
50	ADJUSTER PLASTIC WHEEL	4
51	SPRING LOADED ADJUST KNOB	2
52	SPRING SEAT BLOCK	2
53	ADJUSTER SPRING	2
54	AXLE PIN	2
55	IRON STRIP PIN	2
56	ADJUSTER PULLEY	2
57	ADJUSTER IRON STRIP AXLE PIN	6
58	ALLEN BOLT M5x32mm	10
59	NYLON NUT M5	10
60	ADJUSTER T SHAPED SEAT BUSHING	2
61	SWING ARM ASSEMBLY BRACKET (R)	1
62	SWING ARM PULLEY WHEEL BRACKET WITH BUSHING(L)	1
63	SWING ARM PULLEY WHEEL BRACKET WITH BUSHING(R)	1

64	TOP PULLEY WHEEL BRACKET(R)	1
65	RESISTANCE CYLINDER	2
66	RESISTANCE IRON CORE	2
67	CYLINDER HOUSING TUBE	2
68	RESISTANCE PLASTIC CAP	2
69	RESISTANCE PLASTIC CAP W/PIVOT	2
70	CABLE	2
71	LARGE CLIP	4
72	HANDLES	2
73	SEAT SUPPORT FRAME	1
74	SEAT HANDLE BAR	2
75	SEAT HANDLE BAR GRIPS <t31.4x<t25.4x470	2
76	ALLEN BOLT M6x12mm	8
77	SPRING WASHER	8
78	REMOVABLE LEG TUBE	1
79	BUMPER	1
80+118	SHORT HITCH PIN WITH LANYARD	1
81+118	LONG HITCH PIN W/LANYARD	1
82	LEG LIFT TUBE	1
83	LOWER LEG BAR(SHORT)	1
84	UPPER LEG BAR(LONG)	1
85	FOAM PADS <t90x<t22.2x165	4
86	LEG BAR CAP <t22.2	4
87	PLASTIC BUSHING	2
88	LAT BAR	1
89	LAT BAR CAP <t31.8	2
90	LAT BAR FOAM GRIP <t31.8x<t37.8x275	2
91	RIGHT ADJUSTER SHROUD (RF)	1
92	LEFT ADJUSTER SHROUD (RR)	1
93	ALLEN BOLT M8x15mm(SEAT BACK REST)	8
94	FOOT HARNESS	2
95	SMALL CLIP	2
96	ALLEN Bolt M10x72mm(THREAD LENGTH 15mm)	2
97	ALLEN Bolt M10x112mm(THREAD LENGTH 20mm)	2

98	ALLEN Bolt M10x57mm(THREAD LENGTH 15mm)	2
99	ALLEN Bolt M10x30mm	6
100	SPRING WASHER M10x2.5t	6
101	HEX BOLT M8x20mm	4
102	M9 LARGE WASHER q;30xq;9x2.0t	2
103	M9 SMALL WASHER q;20xq;9x2.0t	2
104	HEX BOLT M8x49mm(THREAD LENGTH 10mm)	2
105	ACORN NUT M8	2
106	ALLEN SPACER BOLT	1
107	ALLEN BOLT 5mm	1
108	ALLEN BOLT M10x98mm(THREAD LENGTH 15mm)	6
109	ALLEN BOLT M10x115mm(THREAD LENGTH 15mm)	2
110	ALLEN BOLT M8x25	4
111	ALLEN WRENCH 6mm	1
112	ALLEN WRENCH 8mm	1
113	ALLEN WRENCH+SCREW DRIVER 5mm	1
114	SEAT	1
115	BACKREST	1
116	HEX WRENCH	2
118	LANYARD	2
119	PHILLIPS BOLT M5*4	2
120	RUBBER PADDING PULLEY SHROUND	2
121	PHILLIPS BOLT M5*20	2

8.3 Exploded Drawing

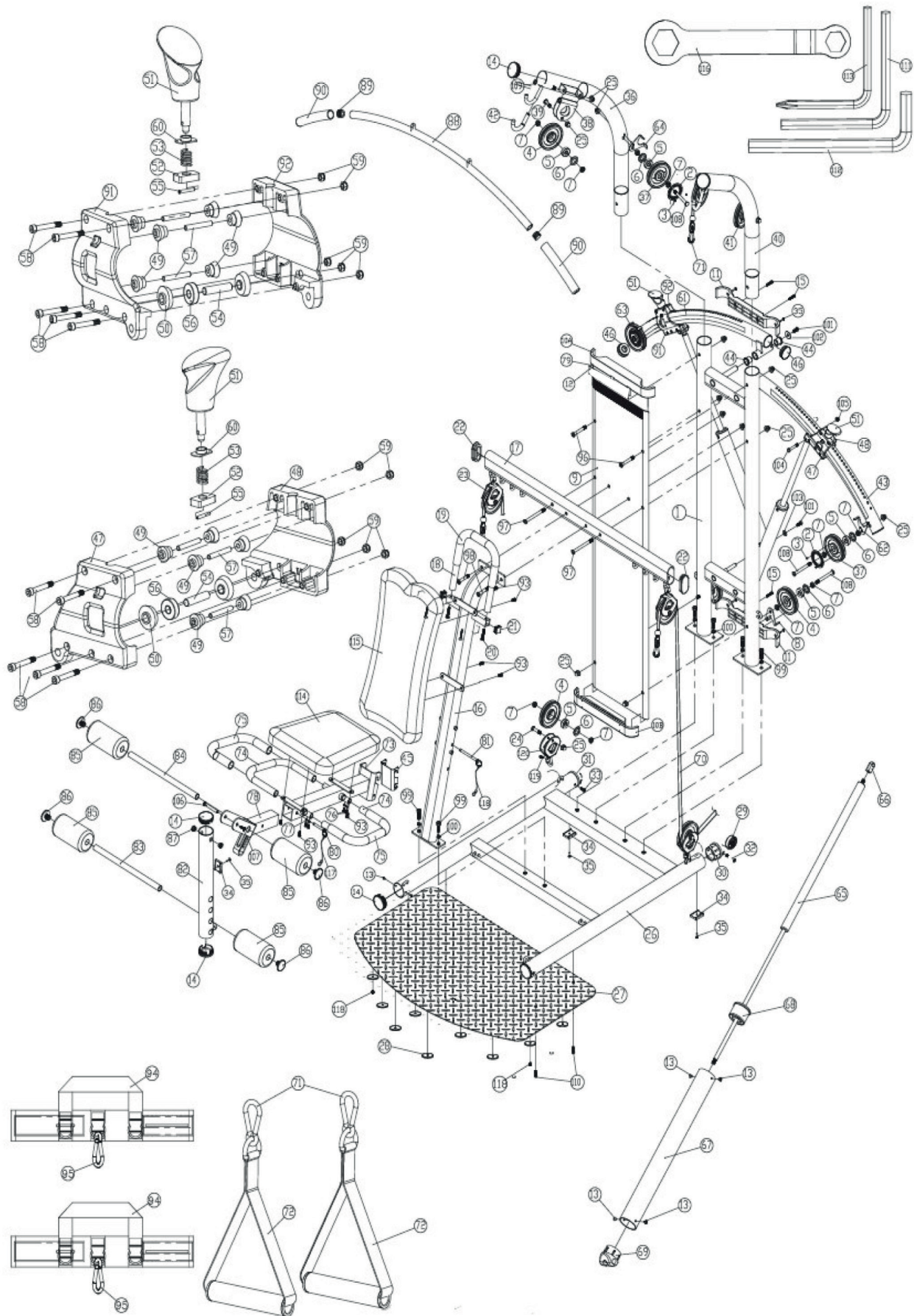

Training equipment from Taurus® is subject to strict quality control. However, if a fitness equipment purchased from us does not work perfectly, we take it very seriously and ask you to contact our customer service as indicated. We are happy to help you by phone via our service hotline.

Error Descriptions

Your fitness equipment is developed for long-term, high-quality training. However, should a problem arise, please first read the operating instructions. For further assistance, please contact your contract partner or call our service hotline. To ensure your problem is solved as quickly as possible, please describe the defect as exactly as possible.

In addition to the statutory warranty, we provide a warranty for every fitness equipment purchased from us according to the following provisions.

Your statutory rights are not affected.

Warranty

The warranty is the first/original buyer and/or any person who received a newly purchased product as a gift from the original buyer.

Warranty period

The warranty periods, shown on our web shop, begin on delivery of the fitness equipment. The respective warranty periods for your equipment can be found on its product website.

Repair Costs

According to our choice, there will either be a repair, a replacement of individual damaged parts or a complete replacement. Spare parts, that have to be mounted while assembling the equipment, have to be replaced by the warranty personally and are not a part of repair. After the expiration of the warranty period for repair costs, a pure parts warranty applies, which does not include the repair, installation and delivery costs.

The terms of use are defined as follows:

- + Home use: solely for private use in private households up to 3 hours per day
- + Semi-professional use: up to 6 hours per day (e. g. rehabilitation centres, hotels, clubs, company gyms)
- + Professional use: more than 6 hours per day (e. g. commercial gyms)

Warranty Service

Within the warranty period, equipment which develops faults as a result of material or manufacturing defects, will be repaired or replaced at our discretion. Ownership of equipment or parts of equipment which have been replaced is transferred to us. The warranty period is not extended nor does a new warranty period begin following repair or replacement under the warranty.

Warranty Conditions

For the warranty to be valid, the following steps must be taken:

Please contact our customer service by email or phone. If the product under warranty has to be sent in for repair, the seller bears costs. After expiry of the warranty, the buyer bears the costs of transport and insurance. If the fault is covered by our warranty, you will receive a new or repaired equipment in return.

Warranty claims are invalid in case of damage resulting from:

- + misuse or improper handling
- + environmental influences (moisture, heat, electrical surge, dust, etc.)
- + failure to follow the current safety measures for the equipment
- + failure to follow the operating instructions
- + use of force (e. g. hitting, kicking, falling)
- + interventions which were not carried out by one of our authorized service centres
- + unauthorised repair attempts

Proof of Purchase and Serial Number

Please make sure that you are able to provide the appropriate receipt when claiming on your warranty. So that we can clearly identify the model of your equipment, and for the purposes of our quality control, you will need to give the serial number of your equipment, when contacting the service team. Where possible please have your serial number and your customer number ready when you call our service hotline. It will help us to deal with your request swiftly.

If you cannot find the serial number on your fitness equipment, our service team is at your disposal to offer further information.







































Service outside of the Warranty Period

We are also happy to issue an individual cost estimate if there is a problem with your fitness equipment after the warranty has expired, or in cases which do not fall under the terms of the warranty, e. g. normal wear and tear. Please contact our customer service team to find a quick and cost-effective solution to your problem. In such a case you will be responsible for the delivery costs.

Communication

Many problems can be solved just by speaking to us as your specialist supplier. We know how important it is to you as a user of the fitness equipment to have problems solved quickly and simply, so you can enjoy working out with minimal interruption. For that reason, we also want to resolve your queries quickly and in a straightforward manner. Thus, please always keep your customer number and the serial number of the faulty equipment handy.

10 CONTACT

DE	DK	FR
<p>TECHNIK</p> <p> +49 4621 4210-900</p> <p> +49 4621 4210-698</p> <p> technik@sport-tiedje.de</p> <p> Öffnungszeiten entnehmen Sie unserer Homepage.</p>	<p>TEKNIK OG SERVICE</p> <p> 80 90 16 50</p> <p>+49 4621 4210-945</p> <p> info@fitshop.dk</p> <p> Åbningstider kan findes på hjemmesiden.</p>	<p>TECHNIQUE & SERVICE</p> <p> +33 (0) 189 530984</p> <p>+49 4621 42 10 933</p> <p> info@fitshop.fr</p> <p> Vous trouverez les heures d'ouverture sur notre site Internet.</p>
<p>SERVICE</p> <p> 0800 20 20277 (kostenlos)</p> <p> 04621 4210 - 0</p> <p> info@sport-tiedje.de</p> <p> Öffnungszeiten entnehmen Sie unserer Homepage.</p>	<p>PL</p> <p>DZIAŁ TECHNICZNY I SERWIS</p> <p> 22 307 43 21</p> <p>+49 4621 42 10-948</p> <p> info@fitshop.pl</p> <p> Godziny otwarcia można znaleźć na stronie głównej.</p>	<p>BE</p> <p>TECHNIQUE & SERVICE</p> <p> 02 732 46 77</p> <p>+49 4621 4210 933</p> <p> info@fitshop.be</p> <p> Vous trouverez les heures d'ouverture sur notre site Internet.</p>
UK	NL	INT
<p>CUSTOMER SUPPORT</p> <p> 00800 2020 2772</p> <p>+494621 4210 944</p> <p> info@sport-tiedje.co.uk</p> <p> You can find the opening hours on our homepage.</p>	<p>TECHNISCHE DIENST & SERVICE</p> <p> +31 172 619961</p> <p> service@fitshop.nl</p> <p> De openingstijden vindt u op onze homepage.</p>	<p>TECHNICAL SUPPORT & SERVICE</p> <p> +49 4621 4210-944</p> <p> service-int@sport-tiedje.de</p> <p> You can find the opening hours on our homepage.</p>
ES	AT	CH
<p>TECNOLOGÍA Y SERVICIOS</p> <p> 911 238 029</p> <p> info@fitshop.es</p> <p> Consulta nuestro horario de apertura en la página web.</p>	<p>TECHNIK & SERVICE</p> <p> 0800 20 20277 (Freecall)</p> <p>+49 4621 42 10-0</p> <p> info@sport-tiedje.at</p> <p> Öffnungszeiten entnehmen Sie unserer Homepage.</p>	<p>TECHNIK & SERVICE</p> <p> 0800 202 027</p> <p>+49 4621 42 10-0</p> <p> info@sport-tiedje.ch</p> <p> Öffnungszeiten entnehmen Sie unserer Homepage.</p>

Please find a detailed overview including address and opening hours for all stores of the Sport-Tiedje Group in Germany and abroad on the following website:

www.sport-tiedje.com/en/stores

WE LIVE FITNESS

WEBSHOP AND SOCIAL MEDIA

Sport-Tiedje is Europe's largest specialist store for home fitness equipment with currently over 70 stores and one of the world's most renowned online mail order companies for fitness equipment. Private customers order via the 25 web shops in the respective national language or have their desired equipment assembled on site. In addition, the company supplies fitness studios, hotels, sports clubs, companies and physio practices with professional equipment for endurance and strength training.

Sport-Tiedje offers a wide range of fitness equipment from renowned manufacturers, high-quality in-house developments and comprehensive services, such as a build-up service and sports scientific advice before and after the purchase. The company employs numerous sports scientists, fitness trainers and competitive athletes.

Visit us also on our social media platforms or our blog!



www.sport-tiedje.co.uk
www.sport-tiedje.de/blog



www.facebook.com/SportTiedje



www.instagram.com/sporttiedje



www.youtube.com/user/sporttiedje

TAURUS

 cardiostrong

BODYCRAFT

 cardiojump

 **DUKEFITNESS**

DARWIN

Notes

Notes

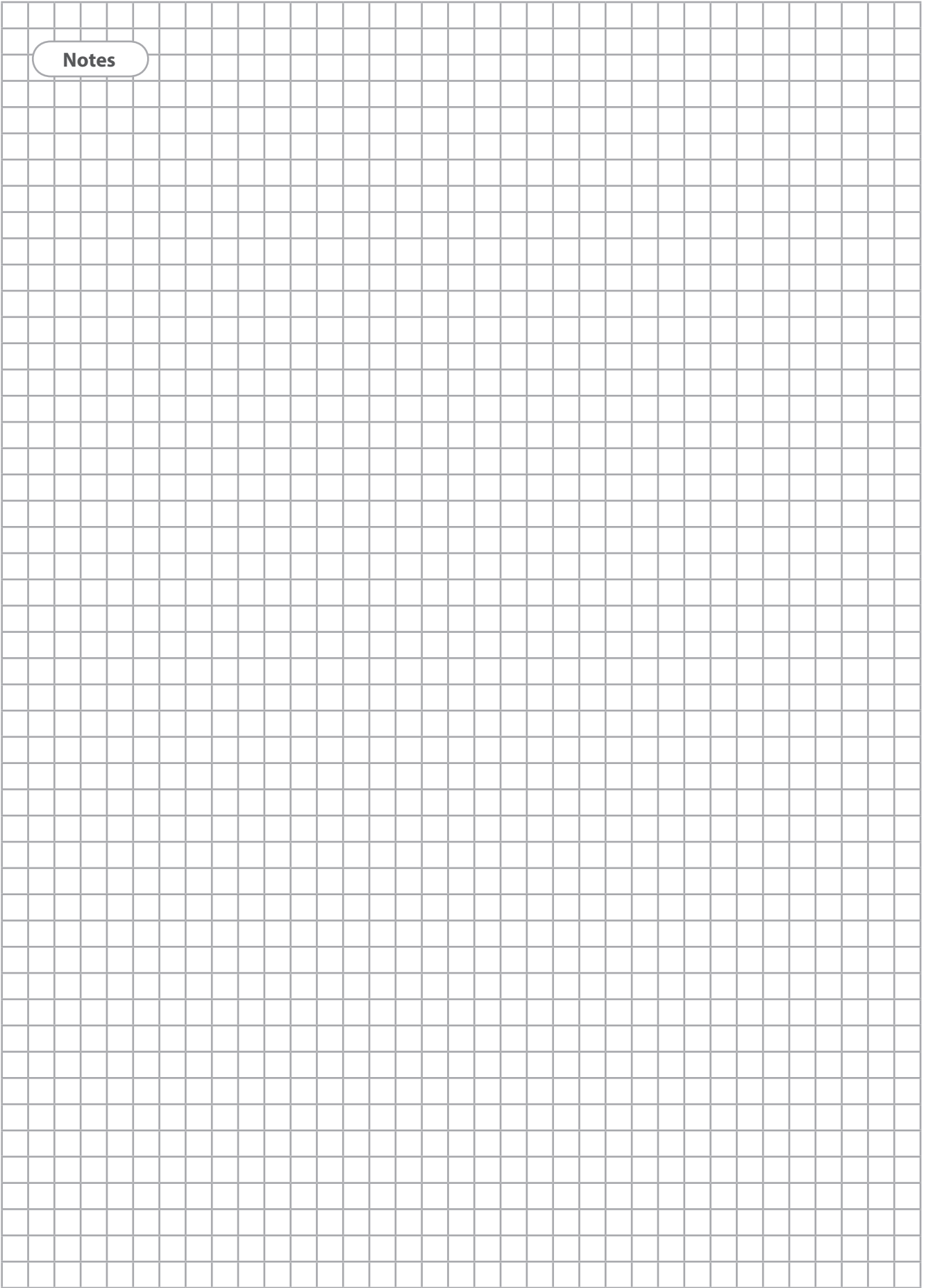

TAURUS[®]

Multi-gym Ultra Force