

TAURUS®

Assembly and Operating Instructions



max. 200 kg



~ 30-60 Min.



145 kg

TFT10.03.06

Art. No. TF-T10.3PRO-3

Treadmill T10.3 Pro

Content

1	GENERAL INFORMATION	7
1.1	Technical Data	7
1.2	Personal Safety	8
1.3	Electrical Safety	9
1.4	Set-Up Place	10
2	ASSEMBLY	11
2.1	General Instructions	11
2.2	Scope of Delivery	12
2.3	Assembly	13
3	OPERATING INSTRUCTIONS	18
3.1	Console display	18
3.2	Button functions	19
3.3	Fitness programmes	20
3.3.1	Quick Start	20
3.3.2	Manual programme	21
3.3.3	Low speed programme	21
3.3.4	Pre-set programmes	22
3.3.5	User-defined programmes	24
3.3.6	Heart rate-oriented programmes	25
3.3.7	Training programme	26
3.4	Body fat test	27
4	STORAGE AND TRANSPORT	28
4.1	General Instructions	28
4.2	Transportation Wheels	28
5	TROUBLESHOOTING, CARE AND MAINTENANCE	29
5.1	General Instructions	29
5.2	Faults and Fault Diagnosis	29
5.3	Care and Maintenance	30
5.3.1	Adjusting the Running Mat	30
5.3.2	Re-tensioning the Running Mat	31
5.3.3	Lubricating the Running Mat	31
5.4	Maintenance and Inspection Calendar	32
6	DISPOSAL	32

7	RECOMMENDED ACCESSORIES	33
8	ORDERING SPARE PARTS	34
8.1	Serial Number and Model Name	34
8.2	Parts List	35
8.3	Exploded Drawing	40
9	WARRANTY	41
10	CONTACT	43

Dear customer,

Thank you for choosing a high-quality equipment of the brand Taurus®. Taurus® offers sports and fitness equipment for the sophisticated home sport and the equipment of fitness studios and business customers. With Taurus® fitness equipment, the focus is on what sport is all about: maximum performance! Therefore, the equipment is developed in close consultation with athletes and sports scientists. Because athletes know best what makes perfect fitness equipment.

Further information can be found at www.sport-tiedje.com.

Intended Use

The equipment may only be used for its intended purpose.

This fitness equipment is suitable for home use, semi-professional use and commercial or professional use. The semi-professional sector includes, for example, institutional facilities such as hospitals, schools, hotels and associations. Professional use refers to commercial use, e.g. in a fitness studio.

Legal Notice

Sport-Tiedje GmbH
Europe's No. 1 for home fitness

International Headquarters
Flensburger Straße 55
24837 Schleswig
Germany

Management:
Christian Grau
Sebastian Campmann
Dr. Bernhard Schenkel
No. HRB 1000 SL
Local Court Flensburg
European VAT Number: DE813211547

Disclaimer



©2010 Taurus® is a registered brand of the company SportTiedje GmbH. All rights reserved. Any use of this trademark without the explicit written permission of Sport-Tiedje is prohibited.

Product and manual are subject to change. Technical data can be changed without advance notice.

ABOUT THIS MANUAL

Please carefully read the entire manual before installation and first use. The manual will help you to quickly set up the system and explains how to safely use it. Make sure that all persons exercising with the equipment (especially children and persons with physical, sensory, mental or motor disabilities) are informed about this manual and its contents in advance. In case of doubt, responsible persons must supervise the use of the equipment.



Due to ongoing changes and software optimisations, the manual may have to be updated. If you notice any discrepancies during assembly or use, please refer to the manual uploaded to the webshop. The latest manual is always available there.

This equipment has been manufactured according to the latest safety knowledge. As far as possible, potential safety hazards which could cause injury have been eliminated. Make sure to carefully follow the instructions and that all parts are securely in place. If required, read through the instructions again to correct any mistakes.

Please pay close attention to the safety and maintenance instructions given here. The contract partner cannot be held liable for damage to health, accidents or damage to the equipment when it is not used in accordance with these instructions.

The following safety instructions may appear in this manual:

► **ATTENTION**

This notice indicates potentially hazardous situations which, if not avoided, may result in property damage.

⚠ **CAUTION**

This notice indicates potentially hazardous situations which, if not avoided, may result in slight or minor injuries!

⚠ **WARNING**

This notice indicates potentially hazardous situations which, if not avoided, may result in death or serious injuries!

⚠ **DANGER**

This notice indicates potentially hazardous situations which, if not avoided, will result in death or serious injuries!

ⓘ **NOTICE**

This notice indicates further useful information.

Retain these instructions in a safe place for future reference, maintenance or when ordering replacement parts.

1.1 Technical Data

LED display of

- + speed in km/h
- + training time in min
- + training distance in km
- + calories burnt in kcal
- + heart rate (when using the hand sensors or a chest strap)
- + incline in %

Motor output:	3.5 HP continuous output (AC motor)
Speed range:	0.5 - 24 km/h
Speed hot keys:	8
Incline range:	0 - 15 %
Incline hot keys:	8
Total number of training programmes:	33
Pre-set programmes:	20
Manual programmes:	1
Heart rate-oriented programmes:	3
User-defined programmes:	4
Running surface size (L x W):	160 cm x 56 cm

Weight and dimensions:

Article weight (gross, including packaging):	163 kg
Article weight (net, without packaging):	145 kg
Packaging dimensions (L x W x H):	226 cm x 90 cm x 41.5 cm
Set-up dimensions (L x W x H):	215 cm x 85 cm x 139 cm
Maximum user weight:	200 kg

1.2 Personal Safety

DANGER

- + Before you start using the equipment, you should consult your physician that this type of exercise is suitable for you from a health perspective. Particularly affected are persons who: have a hereditary disposition to high blood pressure or heart disease, are over the age of 45, smoke, have high cholesterol values, are overweight and/or have not exercised regularly in the past year. If you are under medical treatment that affects your heart rate, medical advice is absolutely essential.
- + Note that excessive training can seriously endanger your health. Please also note that heart rate monitoring systems can be inaccurate. If you notice any signs of weakness, nausea, dizziness, pain, shortness of breath, or other abnormal symptoms, stop exercising immediately and seek advice from your doctor if necessary.

WARNING

- + This equipment may not be used by children under the age of 14.
- + Children should not be allowed unsupervised access to the equipment.
- + Persons with disabilities must have a medical license and must be under strict observation when using the equipment.
- + The equipment is strictly for use by one person at a time.
- + If your equipment provides a safety key, the clip of the safety key must be attached to your clothing before starting your training. In the event of a fall, the EMERGENCY STOP of the equipment can be initiated.
- + Keep your hands, feet and other body parts, hair, clothing, jewellery and other objects well clear of moving parts.
- + During use, wear suitable sports clothing rather than loose or baggy clothing. When wearing sports shoes, make sure they have suitable soles, preferably made of rubber or other non-slip materials. Shoes with heels, leather soles, studs or spikes are unsuitable. Never exercise barefoot.

CAUTION

- + If your equipment needs to be connected to the power supply with a mains cable, make sure that the cable is not a potential tripping hazard.
- + Make sure that nobody is within the range of motion of the equipment during training so as not to endanger you or other persons.

ATTENTION

- + Do not insert any objects of any kind into the openings of the device.

1.3 Electrical Safety

DANGER

- + In order to reduce the risk of an electric shock, always unplug the equipment from the mains socket immediately after your workout, before assembly or dismantling, and before maintenance or cleaning. Do not pull on the cable.

WARNING

- + Do not leave the equipment unattended while the mains cable is plugged into the mains socket. During your absence, the mains cable must be removed to prevent improper use by third parties or children.
- + If the mains cable or plug is damaged or defective, contact your contract partner. In the meantime, the equipment must not be used.

ATTENTION

- + The equipment requires a mains connection of 220-230 V with 50 Hz mains voltage.
- + The equipment may only be connected directly to an earthed socket using the supplied mains cable. Extension cables must conform to VDE guidelines. Always completely unwind the mains cable.
- + The socket must be protected by a fuse with a minimum fuse rating of "16 A, slow blow".
- + Do not make any changes to the mains cable or the mains plug.
- + Keep the mains cable away from water, heat, oil and sharp edges. Do not route the mains cable underneath the equipment or under a carpet or rug, and do not place any objects on top of it.
- + If your purchased item is equipped with a TFT console, software updates must be carried out regularly. Follow the instructions on the console to perform the update(s).
- + The software systems on gym equipment with TFT consoles are set up only for the pre-installed apps. Do not install any additional apps.

NOTICE

- + The pre-installed apps on TFT consoles are produced and provided by external manufacturers. Sport-Tiedje does not take any responsibility for the availability, functionality or contents of these apps.

1.4 Set-Up Place



WARNING

+ Do not place the equipment in main corridors or escape routes.



CAUTION

+ The training room should be well ventilated during training and not be exposed to any draughts.

+ Choose the place in which to set up the equipment such that there is enough free space/clearance to the front, the rear and to the sides of the equipment.

+ The set-up and mounting surface of the equipment should be flat, loadable and solid.

ATTENTION

+ The device may only be used in one building, in sufficiently tempered and dry rooms (ambient temperatures between 10°C and 35°C). The equipment should not be used outdoors or in rooms with high humidity (over 70%) like swimming pools.

+ A floor protective mat/equipment underlay can help to protect high-quality floor coverings (parquet, laminate, cork, carpets) from dents and sweat and can help to level out slight unevenness.

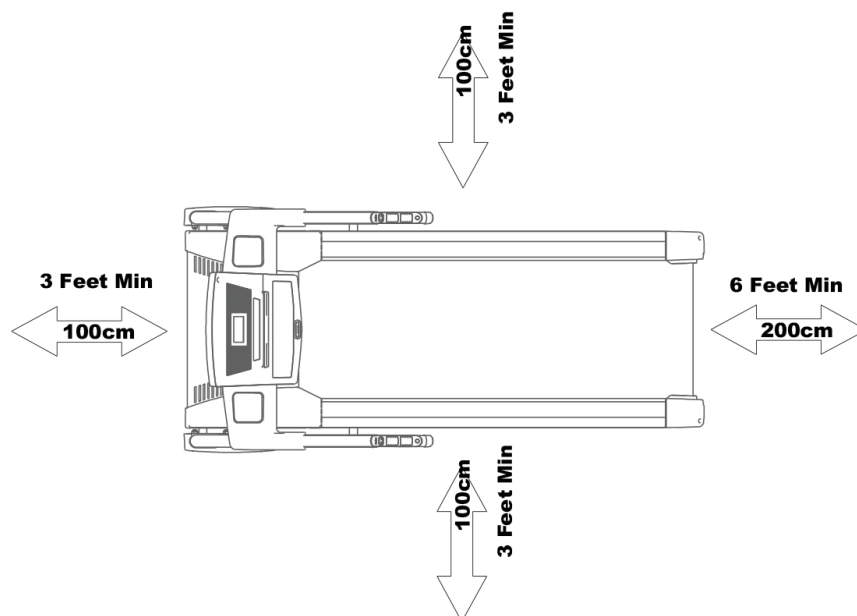

2.1 General Instructions



DANGER

- + Do not leave any tools, packaging materials such as foils or small parts lying around, as otherwise there is a danger of suffocation for children. Keep children away from the equipment during assembly.



WARNING

- + Pay attention to the instructions attached to the equipment in order to reduce the risk of injuries.



CAUTION

- + Do not open the packaging when it is lying on its side.
- + Ensure to have sufficient room for movement in each direction during assembly.
- + The assembly of the equipment must be carried out by at least two adults. If in doubt, seek the help of another technically skilled person.



ATTENTION

- + To prevent damage to the equipment and the floor, assemble the equipment on a mat or packaging board.



NOTICE

- + In order to make the assembly as simple as possible, some screws and nuts to be used can already be pre-assembled.
- + Ideally, assemble the equipment at its later set-up place.

2.2 Scope of Delivery

The scope of delivery consist of the following parts. At the beginning, check whether all parts and tools belonging to the device are included in the scope of delivery and whether damage has occurred. In the event of complaints, the contractual partner must be contacted directly.

⚠ CAUTION

If parts of the scope of delivery are missing or damaged, the assembly must not be carried out.

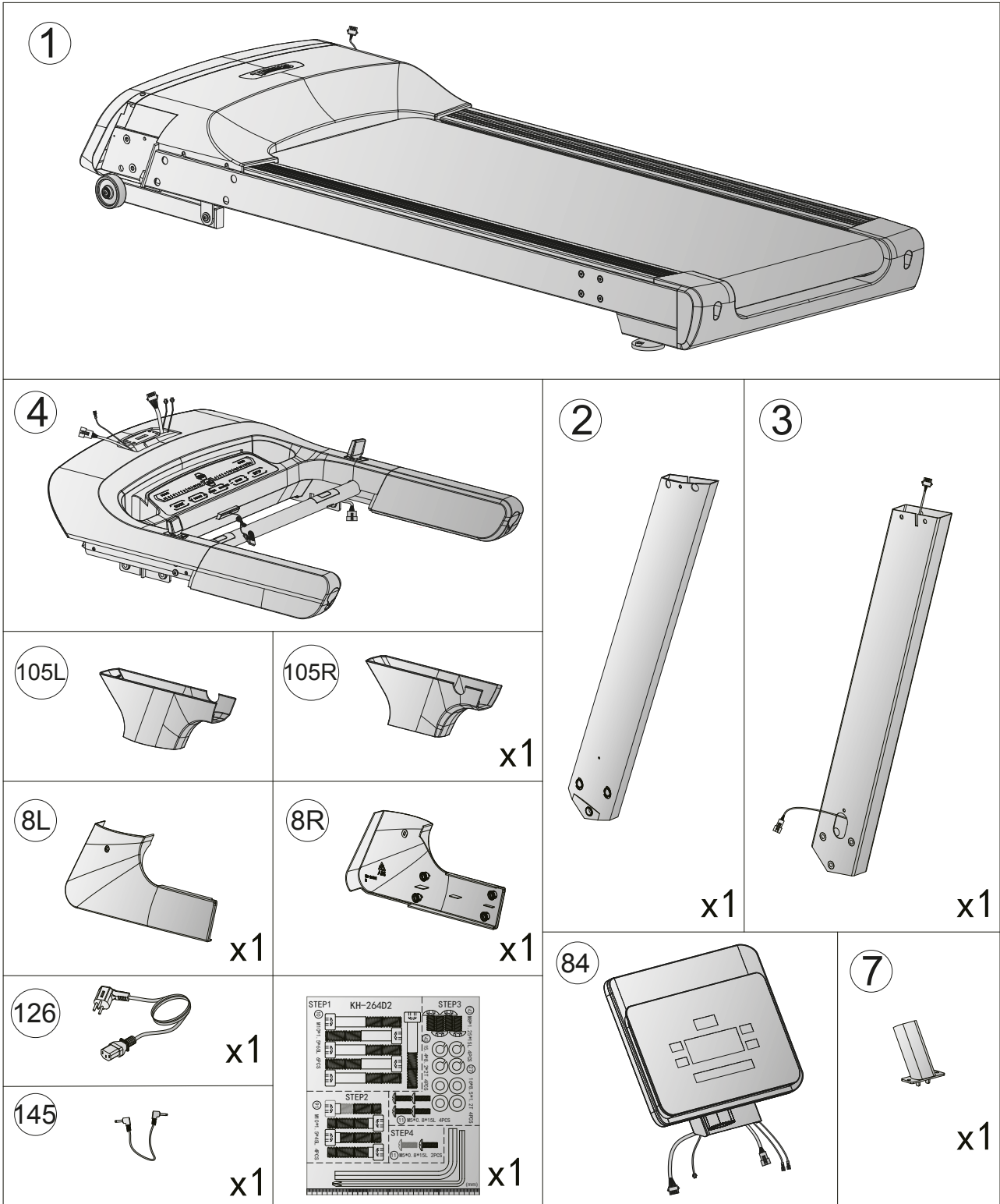

2.3 Assembly

Before assembly, take a close look at the individual assembly steps shown and carry out the assembly in the order given.

NOTICE

- + First loosely screw all parts together and check that they fit properly. Tighten the screws using the tool only when you are instructed to do so.
- + If you have difficulty recognising the graphics, we recommend that you open and/or download the PDF instructions stored in the webshop on your end device (e.g. smartphone, tablet or PC). There you have the option of zooming in closer. Please note that the Adobe Acrobat Reader programme must be installed on your end device in order to open the file.

Step 1: Assembly of the handlebar posts

1. Connect the two cables (121 and 122) with one another.

ATTENTION

Be careful not to pinch the cables in the following step.

2. Fix the two handlebar posts (2 and 3) to the main frame (1) with six allen bolts (10).

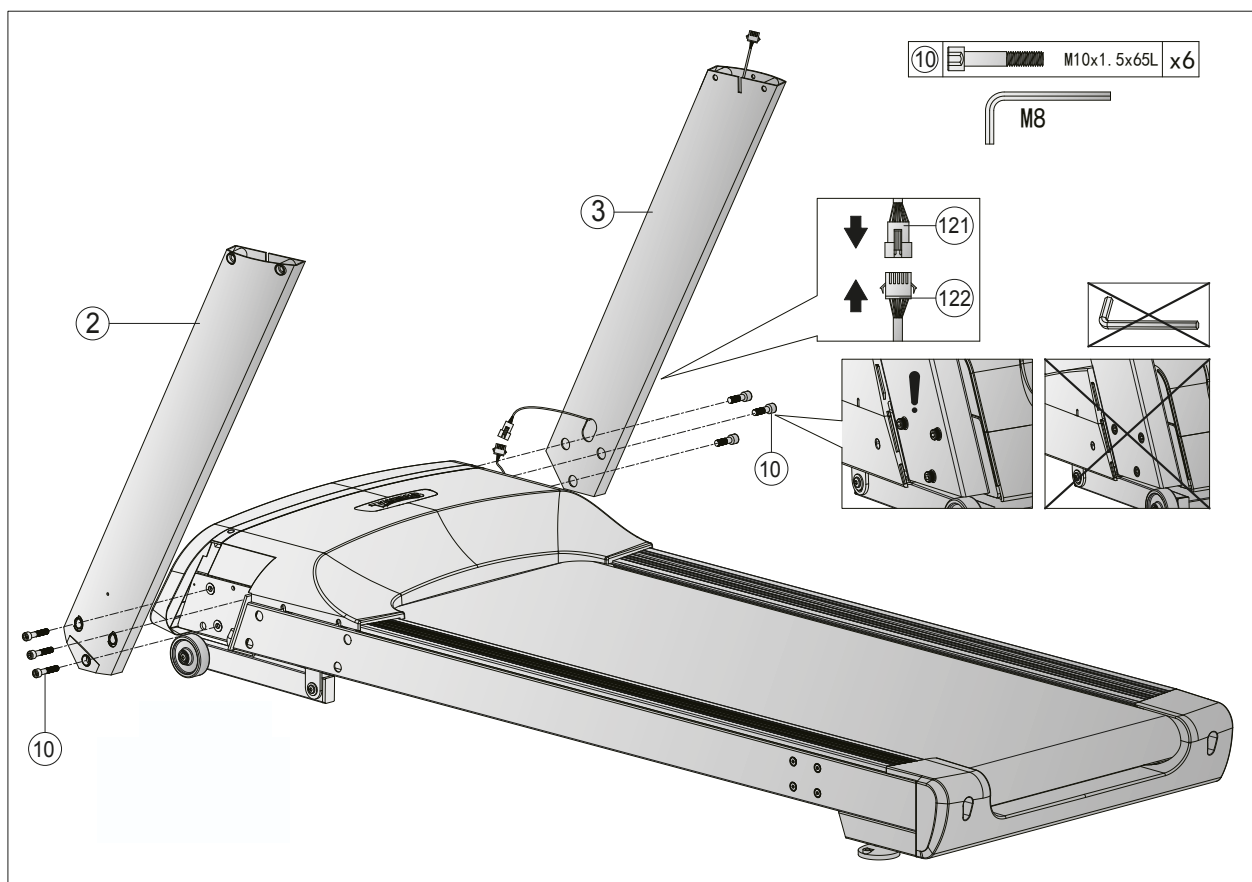

Step 2: Assembly of the handlebar

1. Slide the two covers (105L and 105R) downwards.
2. Connect the two cables (120 and 121) with one another.

► **ATTENTION**

Be careful not to pinch the cables in the following step.

3. Fix the handlebar (4) to the two handlebar posts (2 and 3) with four allen screws (91).

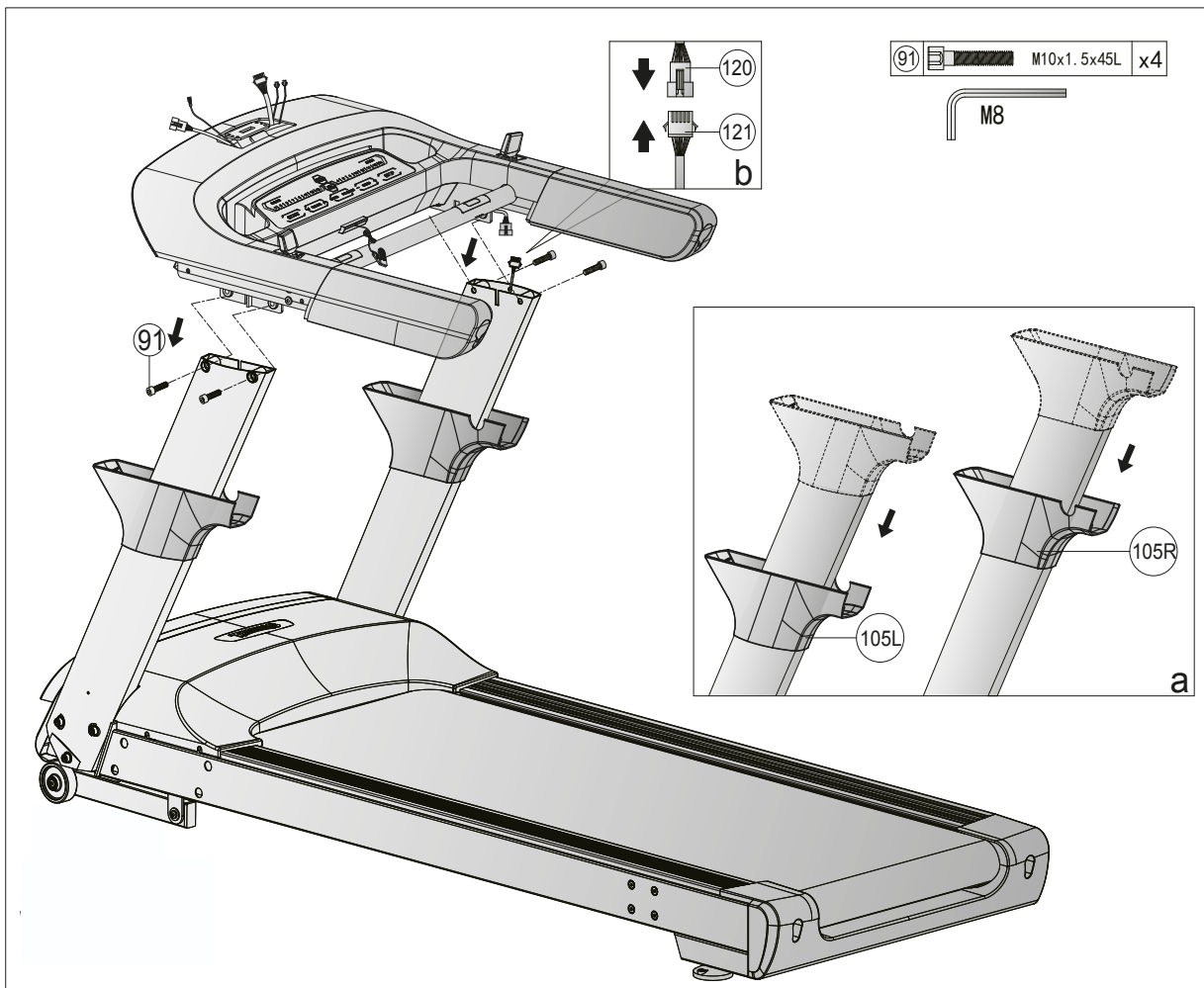

Step 3: Assembly of the console

1. Fix the supporting tube (7) to the handlebar (4) with two allen bolts (142), two spring washers (143) and two flat washers (27).
2. Connect the cables (93, 98, 118 and 120) with their counterparts of the console (84).

► **ATTENTION**

Be careful not to pinch the cables in the following step.

3. Fix the console (84) to the supporting tube (7) with two allen bolts (142), two spring washers (143) and two flat washers (27).
4. Slide the covers (105L and 105R) upwards again and fix them to the handlebar (4) with four cross bolts (11).

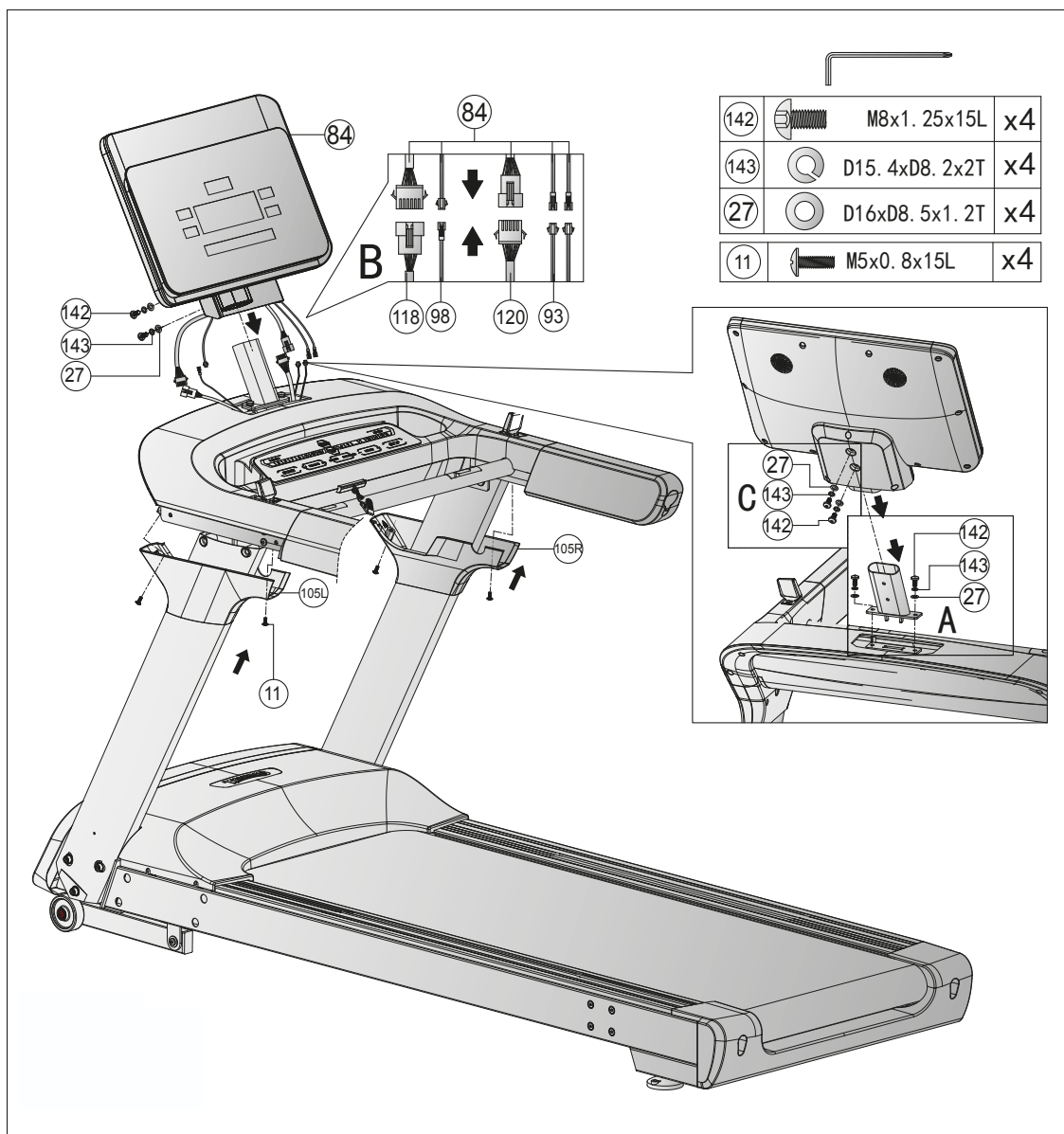

Step 4: Finish the assembly

1. Tighten the six allen bolts (10).
2. Fix the covers (8L and 8R) to the main frame (1) by pressing the lugs on the inside of the covers into the corresponding drill holes of the main frame until they engage audibly.
3. Finally fix the covers (8L and 8R) to the handlebar posts (2 and 3) with two cross bolts (11).

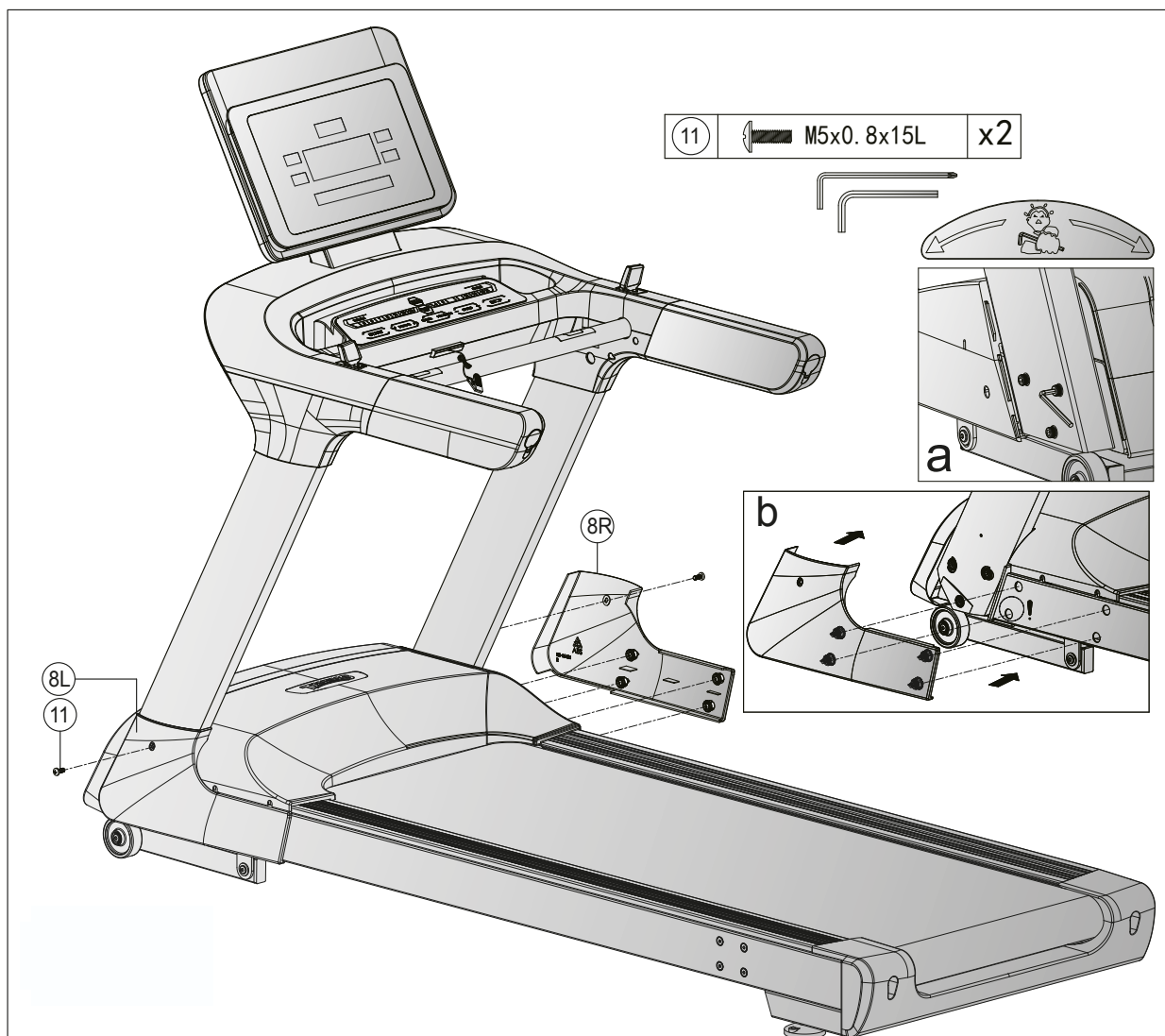

Step 5: Alignment of the feet

If the floor is uneven, you can stabilize the treadmill by turning the two setting screws under the main frame.

1. Lift the treadmill on the desired side and rotate the setting screws under the main frame.
2. Rotate the screws clockwise in order to remove them and to raise the running surface.
3. Rotate them counterclockwise in order to lower the running surface.

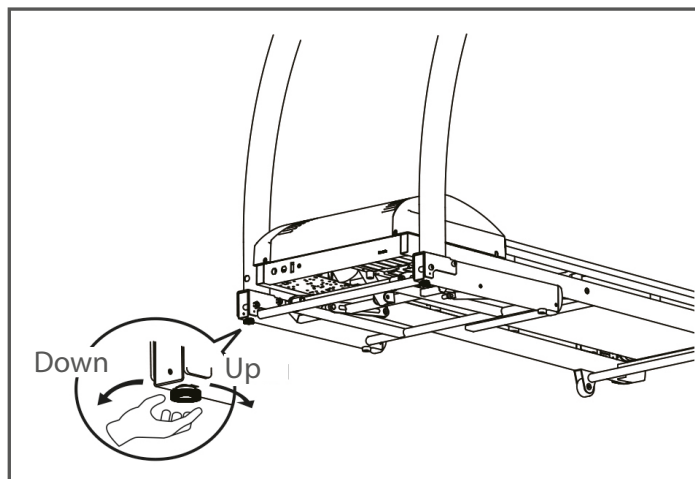

Step 6: Connecting the equipment to the mains supply

► ATTENTION

The equipment must not be connected to a multiple socket, otherwise it cannot be guaranteed that the equipment will be supplied with sufficient power. Technical errors can result.

Plug the power plug into a wall outlet that complies with the instructions in the chapter on electrical safety.

Step 7: Using the holder for mobile devices

1. Place your mobile device onto the holder (C) above the console (84).
2. Pull out the fixing hook (A) that is located on the back of the console cover and fix it at the top of your device.

ⓘ NOTICE

The scope of delivery contains a buffer strap. This can optional be stuck between your device and the console cover if there is knocking sound during workout. The buffer strap has to be stuck onto the top of the console cover.

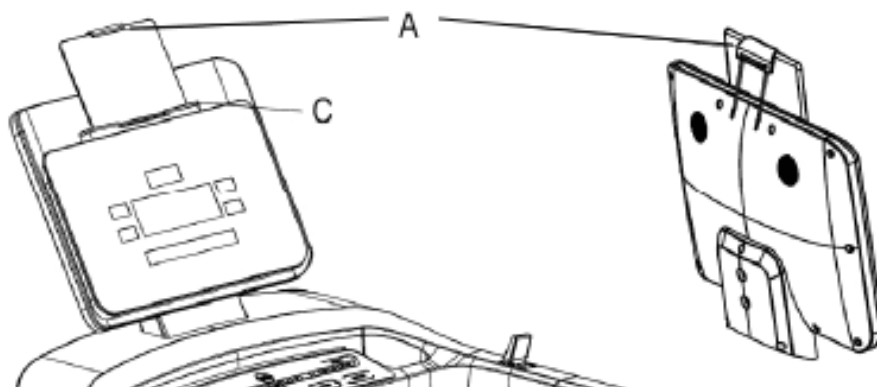

3 OPERATING INSTRUCTIONS

① NOTICE

Familiarise yourself with all the functions and setting options of the device before starting training. Have the proper use of this product explained to you by a specialist.

SAFETY KEY

⚠ WARNING

- + For your safety, the device is equipped with an EMERGENCY STOP function. The equipment can only be operated if the safety key is correctly attached to the contact point of the cockpit. If the safety key is no longer on the contact point, the equipment automatically stops. Therefore, the Safety Key cord with the clip must be attached to your clothing before every training session. If you want to quickly stop the treadmill, if you can no longer control the speed, or if another emergency occurs, remove the safety key from the cockpit using the cord.
- + To enable the safety key to detach from the contact point of the cockpit in the event of a fall, the safety key clip must be firmly attached to your clothing!
- + Make sure that the safety key is not accessible to children.

3.1 Console display

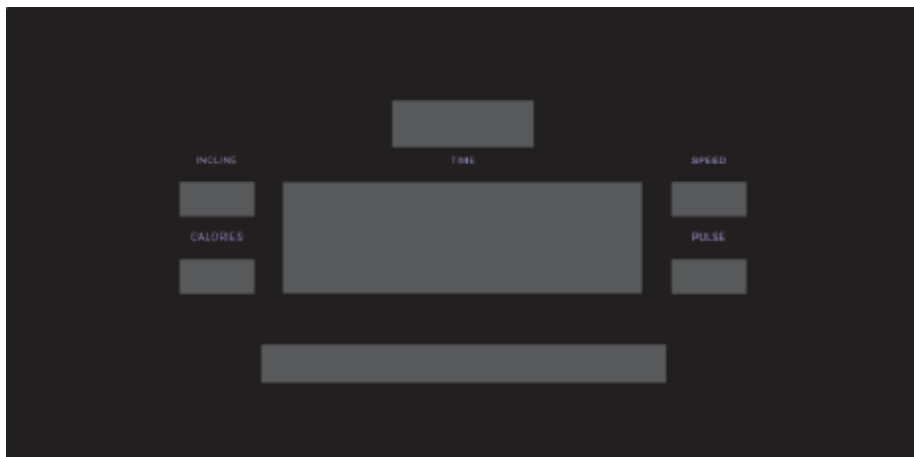

INCLINE	Indicates the current incline level between 1 - 15 %.
DISTANCE	Indicates the covered distance between 0.0 - 9999 km.
TIME	Indicates the already elapsed or remaining training time between 00:00 – 99:59 minutes.
PULSE	Indicates your current heart rate between 40 - 220 bpm.
CALORIES	Indicates the burnt calories between 0 – 999 Kcal.
HR	Indicates the current heart rate accounts in dependence of the target heart rate percentage.
SPEED	Indicates the current speed between 0.5 - 24 km/h.

3.2 Button functions

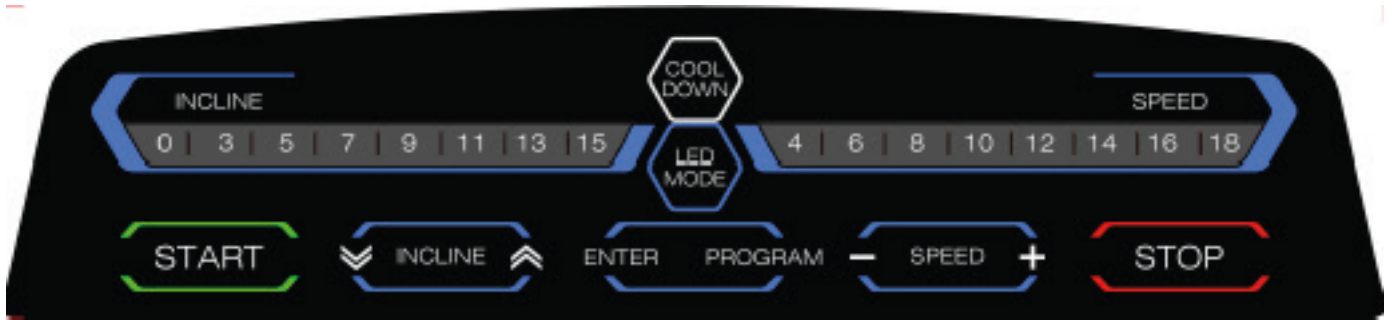

START	With this button you can start a training programme. When you are in the main menu, you can start your training via quick start. When your training is paused, you can continue with your training by pressing this button.
STOP	With this button you can pause or end your training and return to the main menu.
SPEED	With these buttons you can adjust the speed. You can adjust the speed in four ways: <ol style="list-style-type: none"> 1. The eight quick keys on the console (18/16/14/12/10/8/6/4). For example, when you press on the 12 the treadmill will adjust the speed to exact 12 km/h. 2. The buttons on the console (+ and -) 3. The switch on the right handrail. <p>ⓘ NOTICE If you tap on the little icon between the buttons on the touch screen, you will be able to type in your desired speed.</p>
INCLINE	With these buttons you can adjust the incline. You can adjust the incline in three ways: <ol style="list-style-type: none"> 1. The eight quick keys on the console (15/13/11/9/7/5/3/0). When you press on the 11 the treadmill will adjust the incline to exact 11%. 2. The arrow buttons on the console. 3. The switch on the left handrail. <p>ⓘ NOTICE If you tap on the little icon between the buttons on the touch screen, you will be able to type in your desired incline.</p>
COOL DOWN	With this button you can start the cool down phase at any time. Speed and incline will be reduced until the treadmill has come to a stop and has returned to its original position.
ENTER	With this button you confirm your entries.

LED MODE	<p>With this button you enter the LED settings.</p> <p>Running Mode: In this mode, the LED lights glow in different colours depending on the speed level: 0-6 KPM - Yellow, 6.1-12 KPM - Green, >12 KPM - Red</p> <p>Neutral Mode: In this mode, the LED lights glow in a neutral white colour.</p> <p>Multi Color Mode: Here you can choose the colour yourself. Use the SPEED and INCLINE buttons and confirm your choice with the ENTER button. You can choose between the following colours: red, blue, green, orange, pink or purple.</p> <p>OFF: Switch off the LED lights.</p>
PROGRAM	In the main menu, this button will take you directly to the pre-set programmes.

3.3 Fitness programmes

In the main menu you can choose from many different programmes. This includes a manual programme, pre-set programmes, heart rate-oriented programmes, a training programme and a body fat test.

3.3.1 Quick Start

When you are in the main menu, press the START button to start a training session via quick start. Alternatively you can also press the SPEED- or INCLINE buttons or use the switches on the handrails to select the quick start programme manually. Press the ENTER button to confirm.

3.3.2 Manual programme

1. When you are in the main menu, use the SPEED- or INCLINE buttons or the switches on the handrails to select the manual programme (MANUAL). Confirm with the ENTER button.
2. Use the SPEED- or INCLINE buttons or the switches on the handrails to set your desired training time, distance or calories. Press the ENTER button to confirm.

Speed and incline can be adjusted manually during your training.

3. Press the START button to start the programme.
4. Press the STOP button to pause your training.

The speed will be reduced slowly until the treadmill comes to a stop. In case an incline level has been set, the treadmill will remain in that position.

- 4.1. Press the STOP button again to end your training. Press the STOP button one more time to return to the main menu.
- 4.2. Press the START button to continue with your training.

→ *Upon completion of the programme the console will start the cool down phase automatically.*

3.3.3 Low speed programme

1. When you are in the main menu, use the SPEED- or INCLINE buttons or the switches on the handrails to select the manual programme (LOW SPEED). Confirm with the ENTER button.
2. Use the SPEED- or INCLINE buttons or the switches on the handrails to set your desired training time, distance or calories. Press the ENTER button to confirm.

Speed and incline can be adjusted manually during your training.

3. Press the START button to start the programme.
4. Press the STOP button to pause your training.

The speed will be reduced slowly until the treadmill comes to a stop. In case an incline level has been set, the treadmill will remain in that position.

- 4.1. Press the STOP button again to end your training. Press the STOP button one more time to return to the main menu.
- 4.2. Press the START button to continue with your training.

→ *Upon completion of the programme the console will start the cool down phase automatically.*

3.3.4 Pre-set programmes

1. When you are in the main menu, use the SPEED- or INCLINE buttons or the switches on the handrails to select the pre-set programmes (PROGRAM). Confirm with the ENTER button.
2. Use the SPEED- or INCLINE buttons or the switches on the handrails to set your desired training time, distance or calories. Press the ENTER button to confirm.
3. Use the SPEED- or INCLINE buttons or the switches on the handrails to choose one of the pre-set programme. Confirm with the ENTER button.
4. Press the START button to start the programme.

The speed and the incline can be adjusted manually during your training. But only in the respective segment.

5. Press the STOP button to pause your training.

The speed will be reduced slowly until the treadmill comes to a stop. In case an incline level has been set, the treadmill will remain in that position.

- 5.1. Press the STOP button again to end your training. Press the STOP button one more time to return to the main menu.

- 5.2. Press the START button to continue with your training.

→ *Upon completion of the programme the console will start the cool down phase automatically.*

Program		Setting time / 16 = period in each section															
		1	2	3	4	5	6	7	8	9	10	11	12	13	14	15	16
P1	SPD	2	2	4	4	3	3	4	3	5	4	2	2	5	5	3	3
	INC	1	1	2	2	3	3	3	1	2	2	3	3	2	2	2	2
P2	SPD	2	2	5	5	4	4	6	4	6	4	2	2	4	4	2	2
	INC	1	1	2	2	3	3	3	2	2	3	4	4	2	2	2	2
P3	SPD	2	2	5	5	4	4	5	4	5	4	2	2	3	3	2	2
	INC	1	1	2	2	2	2	3	1	2	2	2	2	2	2	1	1
P4	SPD	3	3	6	6	7	7	5	8	5	9	6	6	4	4	3	3
	INC	2	2	2	2	3	3	3	2	2	4	6	6	2	2	2	2
P5	SPD	3	3	6	6	7	7	5	8	6	7	6	6	4	4	3	3
	INC	1	1	2	2	4	4	3	2	2	4	5	5	2	2	1	1
P6	SPD	2	2	8	8	6	6	4	5	9	7	5	5	4	4	3	3
	INC	2	2	2	2	6	6	2	3	4	2	2	2	2	2	1	1

P7	SPD	2	2	6	6	7	7	4	4	7	4	2	2	4	4	2	2
	INC	4	4	5	5	6	6	6	9	9	10	12	12	6	6	3	3
P8	SPD	2	2	4	4	6	6	8	7	8	6	2	2	3	3	2	2
	INC	3	3	5	5	4	4	4	3	4	4	3	3	3	3	2	2
P9	SPD	2	2	4	4	5	5	5	6	5	6	3	3	3	3	2	2
	INC	3	3	5	5	3	3	4	2	3	4	2	2	3	3	2	2
P10	SPD	2	2	3	3	5	5	3	3	5	3	6	6	3	3	3	3
	INC	4	4	4	4	3	3	6	7	8	8	6	6	3	3	3	3
P11	SPD	3	3	5	5	8	8	8	9	5	7	6	6	3	3	2	2
	INC	4	4	5	5	6	6	6	9	9	10	12	12	6	6	3	3
P12	SPD	2	2	5	5	5	5	4	4	6	4	2	2	3	3	4	4
	INC	3	3	5	5	6	6	7	12	9	11	11	11	6	6	3	3
P13	SPD	4	4	2	2	6	6	8	6	3	2	6	6	2	2	2	2
	INC	3	3	4	4	6	6	2	3	7	9	5	5	2	2	2	2
P14	SPD	3	3	4	4	4	4	3	5	5	6	3	3	3	3	2	2
	INC	3	3	5	5	4	4	4	3	4	3	2	2	2	2	4	4
P15	SPD	4	4	2	2	4	4	6	8	7	8	6	6	2	2	3	3
	INC	4	4	3	3	4	4	4	3	4	2	3	3	2	2	5	5
P16	SPD	3	3	2	2	5	5	7	3	5	6	7	7	2	2	1	1
	INC	7	7	12	12	9	9	11	11	4	3	3	3	2	2	4	4
P17	SPD	5	5	10	10	8	8	10	8	12	10	5	5	12	12	8	8
	INC	1	1	4	4	6	6	6	1	4	4	6	6	4	4	4	4
P18	SPD	5	5	12	12	10	10	12	10	12	10	10	10	10	10	5	5
	INC	1	1	4	4	4	4	6	1	4	4	6	6	8	8	4	4
P19	SPD	3	3	7	7	5	5	7	6	10	7	3	3	10	10	5	5
	INC	1	1	2	2	4	4	5	1	2	2	4	4	3	3	3	3
P20	SPD	3	3	10	10	7	7	12	7	12	7	7	7	7	7	3	3
	INC	1	1	2	2	4	4	5	2	2	4	6	6	3	3	2	2

3.3.5 User-defined programmes

1. When you are in the main menu, use the SPEED- or INCLINE buttons or the switches on the handrails to select the user-defined programmes (USER). Confirm with the ENTER button.
2. Use the SPEED- or INCLINE buttons or the switches on the handrails to choose one of the four user profiles (U1-U4). Confirm with the ENTER button.
3. Enter your gender, age, weight and the desired training time with the SPEED- or INCLINE buttons or the switches on the handrails. Confirm all your entries with the ENTER button.
4. Now set the speed for all the individual segments with the SPEED buttons or the switch on the right handrail and confirm each entry with the ENTER button. Continue until you have set a speed value for all the segments.
5. Now set the incline for all the individual segments with the INCLINE buttons or the switch on the left handrail and confirm each entry with the ENTER button. Continue until you have set an incline value for all the segments.
6. Press the START button to start the programme.

Speed and incline can be adjusted again during your training. But only in the respective segment.

7. Press the STOP button to pause your training.

The speed will be reduced slowly until the treadmill comes to a stop. In case an incline level has been set, the treadmill will remain in that position.

- 7.1. Press the STOP button again to end your training. Press the STOP button one more time to return to the main menu.
- 7.2. Press the START button to continue with your training.

→ *Upon completion of the programme the console will start the cool down phase automatically.*

3.3.6 Heart rate-oriented programmes

WARNING

Your training equipment is not a medical device. The heart rate measurement of this equipment may be inaccurate. Various factors can affect the accuracy of the heart rate measurement. The heart rate measurement serves only as a training aid.

There are three different heart rate-oriented programmes. Either choose one of the pre-set target heart rates (60% or 80% of your maximum heart rate) or choose „Target HR“ to set a target heart rate yourself. Your maximum heart rate is calculated depending on your age. We recommend a chest strap for these programmes.

1. When you are in the main menu, use the SPEED- or INCLINE buttons or the switches on the handrails to select the heart rate-oriented programmes (HRC). Confirm with the ENTER button.
2. Enter your gender, age, weight and the desired training time with the SPEED- or INCLINE buttons or the switches on the handrails. Confirm all your entries with the ENTER button.
3. Choose either 60%, 80% or THR.
- 3.1. If you have chosen THR you will be able to set the target value yourself (between 72-168).

Speed and incline can be adjusted again during your training.

4. Press the START button to start the programme.
5. Put your hands around the hand pulse sensors or use a chest strap.

NOTICE

In case the console does not receive a signal for 15 seconds the programme will be stopped.

6. Press the STOP button to pause your training.

The speed will be reduced slowly until the treadmill comes to a stop. In case an incline level has been set, the treadmill will remain in that position.

- 6.1. Press the STOP button again to end your training. Press the STOP button one more time to return to the main menu.
- 6.2. Press the START button to continue with your training.

→ *Upon completion of the programme the console will start the cool down phase automatically.*

3.3.7 Training programme

In this programme you are able to set a specific distance that must be covered in a fixed time.

1. When you are in the main menu, use the SPEED- or INCLINE buttons or the switches on the handrails to select the training programme (TRAINING). Confirm with the ENTER button.
2. Set the desired time with the SPEED- or INCLINE buttons or the switches on the handrails and confirm your entry with the ENTER button.
3. Set the desired distance with the SPEED- or INCLINE buttons or the switches on the handrails and confirm your entry with the ENTER button.

Speed and incline can be adjusted again during your training.

4. Press the START button to start the programme.
5. Press the STOP button to pause your training.

The speed will be reduced slowly until the treadmill comes to a stop. In case an incline level has been set, the treadmill will remain in that position.

- 5.1. Press the STOP button again to end your training. Press the STOP button one more time to return to the main menu.
- 5.2. Press the START button to continue with your training.

→ *Upon completion of the programme the console will display a summary of the collected training data.*

3.4 Body fat test

1. When you are in the main menu, use the SPEED- or INCLINE buttons or the switches on the handrails to select the body fat test (FAT). Confirm with the ENTER button.
2. Put your hands around the hand pulse sensors.
3. In 10 seconds the console will calculate your body fat percentage and will display the result in form of a rating.

Possible results:

SEX	Male	Female
AGE	10-99	
HEIGHT	100-200	
WEIGHT	30-150 Kg , 40-400LB	
FAT	<19	UNDERWEIGHT
FAT	=(20-25)	NORMAL WEIGHT
FAT	=(26-29)	OVER WEIGHT
FAT	>30	OBESITY

4.1 General Instructions

► **ATTENTION**

- + Make sure that the equipment is protected from moisture, dust and dirt in the selected storage location. The storage location should be dry and well ventilated and have a constant ambient temperature between 5°C and 45°C.

⚠ **WARNING**

- + The storage location should be chosen so that improper use by third parties or children can be prevented.
- + If your equipment does not have transportation wheels, the equipment must be disassembled before transportation.

4.2 Transportation Wheels

► **ATTENTION**

If you want to transport your equipment over particularly sensitive and soft floor coverings, such as parquet, planks or laminate, lay out the transport route with cardboard or similar to avoid possible floor damage.

1. Stand behind the equipment and lift it until the weight is transferred to the transportation wheels. After that, you easily can move the equipment to a new position. For long transport distances the equipment should be disassembled and safely packed.
2. Select the new location by following the instructions in the section 1.4 of this manual.

5.1 General Instructions



WARNING

+ Do not make any improper changes to the equipment.



CAUTION

+ Damaged or worn components may affect your safety and the life of the equipment. Therefore, immediately replace damaged or worn components. In such a case, contact the contract partner. The equipment must not be used until it has been repaired. If necessary, use only original spare parts.

► ATTENTION

+ In addition to the instructions and recommendations for maintenance and care given here, additional service and/or repair work may be necessary; this must only be carried out by authorised service technicians.

5.2 Faults and Fault Diagnosis

The equipment undergoes regular quality controls during production. Nevertheless, faults or malfunctions may occur. Frequently, individual parts are responsible for these disturbances, an exchange is usually sufficient. Please refer to the following overview for the most common errors and how to correct them. If the equipment still does not function properly, contact your contract partner.

Fault	Cause	Solution
Console only shows lines	Safety key missing	Check if the safety key is inserted and place it in
Running belt tilted	Running belt not aligned	Align running belt in accordance with the instructions
Running belt slips through/stops	Belt tension/lubrication not ok	Check belt tension/lubrication in accordance with the instructions
Scraping noises	Running belt scrapes, because it is not aligned	Align running belt in accordance with the instructions
Display does not show anything	Check plug connections (cables)	Mains switch on "on", make sure that the safety key is inserted
No pulse display	<ul style="list-style-type: none"> + Sources of interference in the room + Unsuitable chest strap + Position of the chest strap incorrect + Batteries empty 	<ul style="list-style-type: none"> + Remove sources of interference (e. g. mobile phone, speakers, WLAN, mover- and cleaning robot, etc.) + Use suitable chest strap (see recommended accessories) + Reposition chest strap and/or moisten electrodes + Change batteries

5.3 Care and Maintenance

The most important maintenance measure is the care of the running mat. This includes adjustment, re tensioning and lubrication of the running mat. Damage resulting from insufficient or neglected care is not covered by the warranty. You should therefore carry out maintenance checks at regular intervals. Be very careful when adjusting and tightening the running mat, as a strong over voltage or under voltage can cause damage to the equipment. The running mat is adjusted at the factory according to the regulations before delivery. However, it may happen that the running mat slips during transport.

By scanning the QR code with the camera function or QR code scanner app of your smartphone/tablet, a video on general maintenance of a treadmill opens on YouTube. The video serves to illustrate the maintenance points described in this manual.

Please note that the video may not be available in your language or with appropriate subtitles.

If you cannot scan QR codes, you can access all Sport-Tiedje videos on YouTube by first opening YouTube and entering "Sport-Tiedje" in the search field.



5.3.1 Adjusting the Running Mat

During training, the running mat should run as centrally and straight as possible. The alignment of the running mat can change depending on the stress and load. Another reason can be the positioning of the equipment on an uneven surface.

CAUTION

During the following maintenance nobody must be on the treadmill!

1. Let the treadmill run at a speed of 5 km/h.
2. If the running mat deviates to the left, turn the left adjusting screw at the rear end of the device max. one $\frac{1}{4}$ turn clockwise and the right adjusting screw max. one $\frac{1}{4}$ turn anticlockwise.
3. If the running mat deviates to the right, turn the right adjusting screw at the rear end of the device max. $\frac{1}{4}$ turn clockwise and the left adjusting screw max. $\frac{1}{4}$ turn anticlockwise.
4. Then observe the mat for about 30 seconds, as the change is not immediately visible.
5. Repeat this procedure until the running mat is straight again. If the running mat cannot be adjusted, please contact your contract partner.

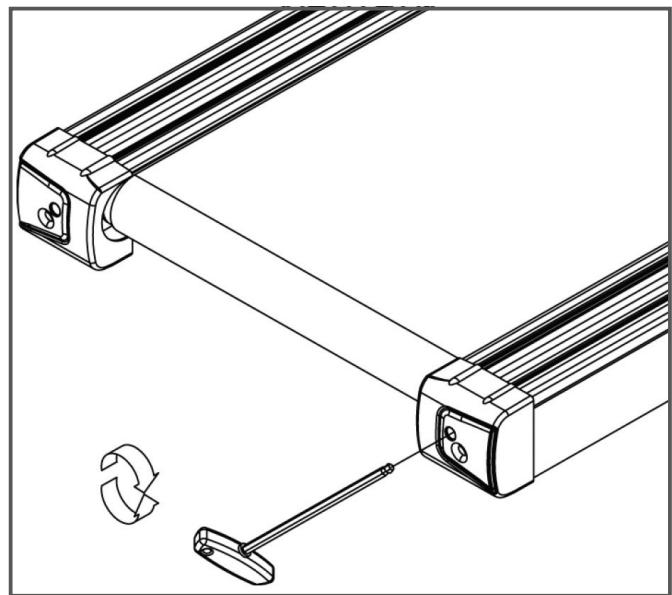

5.3.2 Re-tensioning the Running Mat

If the running mat slips over the rollers during operation (if this is the case, there is a noticeable jerk during running), the running mat must be re tightened.

In most cases, the slipping is caused by stretching of the mat through use. This is perfectly normal.

ⓘ NOTICE

Re-tensioning is carried out using the same adjusting screws that are used for adjustment.

1. Let the treadmill run at a speed of 5km/h.
2. Turn the left and right adjusting screws directly one after the other, max. one ¼ turn clockwise.
3. Then check whether the running mat continues to slip. If this is the case, you must perform the described procedure again.

5.3.3 Lubricating the Running Mat

If the running mat is not sufficiently lubricated, friction increases significantly and this leads to heavy wear of the endless belt, running plate, motor and circuit board. If you feel an increased friction of the running mat, this is an indication that you should lubricate the mat. However, lubrication should be carried out at least every 3 months or every 50 operating hours. Whichever case comes first.

ⓘ NOTICE

If your treadmill is equipped with a folding mechanism, you can also lubricate it when it is folded.

1. Raise the running mat slightly.
2. Apply some lubricating oil or silicone spray to the entire deck and distribute evenly.
3. Continue turning the belt by hand so that the entire surface between the endless belt and the running plate is lubricated.
4. Wipe off the excess lubricating oil or silicone spray.

ⓘ NOTICE

This maintenance must also be carried out after prolonged non-use of the equipment.

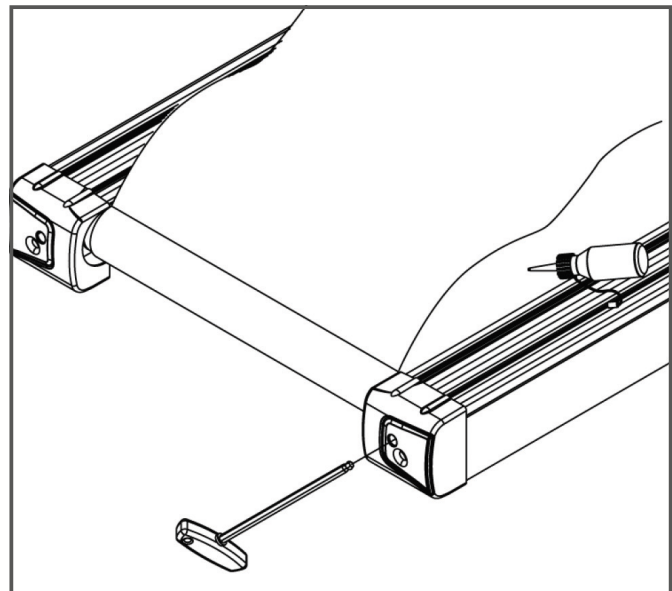

5.4 Maintenance and Inspection Calendar

To avoid damage from body sweat, the equipment must be cleaned with a damp towel (no solvents!) after each training session.

The following routine tasks must be performed at the specified intervals:

Part	Weekly	Monthly	Quarterly	Half-yearly	Yearly
Display console	C	I			
Tension of the running mat				I	
Lubrication of the running mat			I		
Plastic covers	C	I			
Screws and cable connections		I			
Legend: C = clean; I = inspect					

By scanning the QR code with the camera function or QR code scanner app of your smartphone/tablet, a video on general maintenance of a treadmill opens on YouTube. The video serves to illustrate the maintenance points described in this manual.

Please note that the video may not be available in your language or with appropriate subtitles.

If you cannot scan QR codes, you can access all Sport-Tiedje videos on YouTube by first opening YouTube and entering "Sport-Tiedje" in the search field.



6 DISPOSAL

At the end of its operational life, this equipment cannot be disposed of in normal household waste. Instead, it must be disposed of via an electricals recycling centre. Further information can be obtained from your local authority's recycling service.



The materials can be recycled as per their symbols. Through the reuse, recycling of materials or other forms of recovery of old equipment, you make an important contribution to the protection of the environment.

7 RECOMMENDED ACCESSORIES

To make your training experience even more efficient and pleasant, we recommend that you add suiting accessories to your fitness equipment. This could be a **floor mat**, for example, which makes your fitness equipment stand more securely and also protects the floor from falling sweat, but it could also be additional handrails on some treadmills or **silicone spray** to keep moving parts in good shape.

If you have purchased a fitness machine with pulse training and want to train your heart rate, we strongly recommend that you use a compatible chest strap, as this ensures optimum transmission of the heart rate. You may want to buy additional **grips or weights** for multi gyms.

Our range of accessories offers the highest quality and makes training even better. If you would like to find out more about compatible accessories, please go to the detail page of the product in our webshop (the easiest way is to enter the article number in the search field above) and go to the recommended accessories on this page. Alternatively, you can use the QR code provided. Of course, you can also contact our customer service: by telephone, e-mail, in one of our branches or via our social media channels. We will be happy to advise you!



floor mat



chest strap



chest strap contact gel



towels



silicone spray

8.1 Serial Number and Model Name

In order to provide you with the best possible service, please have the model name, article number, serial number, exploded drawing and parts list ready. The corresponding contact options can be found in chapter 10 of this operating manual.

NOTICE

The serial number of your equipment is unique. It's located on a white sticker. The exact position of this sticker is shown in the following illustration.

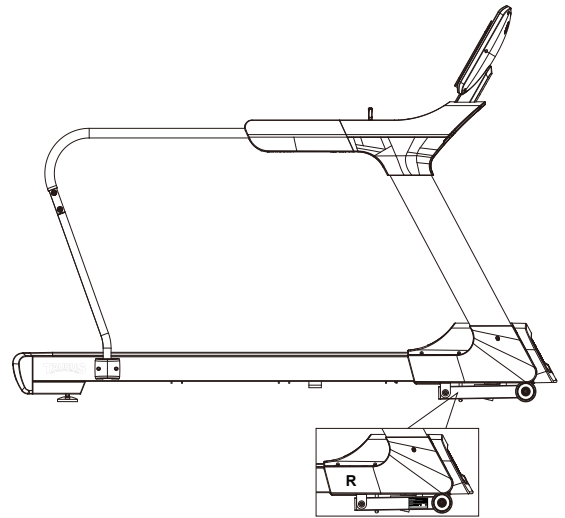

Enter the serial number in the appropriate field.

Serial number:

Brand / Category:

Model Name:

Article Number:

8.2 Parts List

No.	Name	Supplier Parts No.	Specification	Qty.
1	Main frame	264A1-3-1000-J0		1
2	Left handlebar post	264A1-3-1300-J0		1
3	Right handlebar post	264A1-3-1400-J0		1
4	Handlebar set	264A1-3-1500-J1		1
5	Front handlebar set	264A1-3-1550-J0		1
6	Stabilizer	26200-3-1600-J1		1
7	Computer supporting tube	264A1-3-2000-J0		1
8L	Lower cover for handlebar post(-left)	264A1-6-1371-B0	520.7*225.6*52.3	1
8R	Lower cover for handlebar post(right)	264A1-6-1471-B0	520.7*225.6*52.3	1
9	Open plug	264A1-6-2420-B0	D22.5*13.5	8
10	Allen bolt	54010-8-0065-CU7	M10*1.5*65L	6
11	Cross bolt	52605-2-0015-F0	M5*0.8*15L	13
12	CSK inner hexagon bolt	51608-5-0035-F0	M8*1.25*35L	8
13	Wooden board	26200-6-1073-B1	1445*695*25T	1
14	Buffer bar	26200-6-1084-B0	25*2T*1435L	2
15	CSK inner hexagon bolt	51608-5-0025-F0	M8*1.25*25L	8
16	Flat washer	55104-1-1210-NA	D12*D4.3*1.0T	4
17	Running belt	264A1-6-1072-B0	560*3.1T*3410L	1
20	Pedaling plate	264A1-6-1076-00	105*21.4*1455L	2
23	Cross self-tapping screw	52842-2-0015-F0	ST4.2*15L	62
24	Metal clip	26000-6-1086-FC0	D27*D4.3*2T	8
25	Buffer(4)	26100-6-1088-F0	D30*37L*M8	2
26	Buffer(3)	26100-6-1083-B0	D30*37L*M8,95degree	2
27	Flat washer	55108-1-1612-FA	D16*D8.5*1.2T	10
28	Nylon nut	55208-1-2008-FA	M8*1.25*8T	6
29	Allen bolt	50308-5-0020-UF0	M8*1.25*20L	4
30	Rear roller set	26200-3-1200-01	D25*D75*686L	1
27	Flat washer	55108-1-1612-FA	D16*D8.5*1.2T	11
28	Nylon nut	55208-1-2008-FA	M8*1.25*8T	6
29	Allen bolt	50308-5-0020-UF0	M8*1.25*20L	4
30	Rear roller set	26200-3-1200-01	D25*D75*686L	1
31	Inner hex head screw	54010-8-0080-F0	M10*1.5*80L	3

32	Rear cover	264A1-6-2406-B0	789.6*164.7*164.6	1
33	Buffer(1)	26100-6-1081-R0	D30*37L*M8,45degree	2
34	Nylon universal adjusting feet	26200-6-1094-B0	D80*81L	2
35	Front roller set	26200-3-1100-01	D25*D75*694L	1
36	Inner hex head screw	54010-5-0045-F4	M10*1.5*45L	1
37	Multi-groove belt	58004-6-1100-00	250/PJ10	1
38	Motor	261A3-6-1085-00	AC3.5HP	1
39	Nylon nut	55210-1-2010-CA	M10*1.5*10T	6
40	Flat washer	55110-1-2020-CA	D20*D11*2T	12
41	Inner hex head screw	54010-5-0030-C0	M10*1.5*30L	4
42	Flat washer	551E1-1-2820-NA	D28*D14*2T	4
43	Insulating sleeve(1)	26200-6-1063-B0	D20*D10*8T	5
44	Motor buffer	26200-6-1093-B0	65*40*5T	4
45	Fixing plate	26200-6-1071-N0	30*20*4T	3
46	Bolt	50108-5-0060-N0	M8*1.25*60L	1
47	Fixing bracket for motor cover	26100-6-1090-00	32*18*18	4
48	cable tie base	26100-6-1089-00	15*10	2
49	Cross screw	50904-2-0015-N0	ST4*1.41*15L	2
51	Upper motor cover	264A1-6-2401-B0	800*486*129.5	1
52	Al plate with logo on motor cover	264A1-6-2404-B0		1
53	Socket	26100-6-2413-00		1
54	Cross screw	53329-2-0009-D0	ST2.9x9.5L	31
55	Power supplier board	26100-6-2414-B0	130*45*6T	1
56	Switching mode power supplier	261D8-6-2411-00		1
57	Buffer	55308-4-0020-G9	D10.5*20L	2
58	overcurrent protector	261D1-6-2412-00	15A	1
59	Flat washer	55105-1-1208-DA	D12*D5.2*0.8T	2
60	Nylon nut	55205-1-2005-DA	M5*0.8*5T	2
60	Nylon nut	55205-1-2005-DA	M5*0.8*5T	2
61	Lower motor cover	264A1-6-2402-B0	812.5*237.2*180.6	1
62	Allen bolt	54010-8-0050-C4	M10*1.5*50L	1
63	Plastic flat washer	55110-1-2404-BF	D10*D24*0.4T	4
64	Incline	26200-6-1975-02	JS19-B	1
65	Allen bolt	54010-8-0065-C4	M10*1.5*65L	1
66	Wheel	26200-6-1087-B0	D82*35L	2
67	Allen bolt	50308-5-0020-UFO	M8*1.25*20L	6

68	Flat washer	55108-1-2115-FA	D21*D8.5*1.5T	2
69	End cap	55310-2-2550-B8	25*50*14,match 2.0T tube	4
70	Axle	26200-6-1673-N0	D18.7*41L	2
71	Nylon washer	55121-1-3730-0F	D21*D37*3T	4
72	Flat washer	55108-1-2520-FA	D25xD8.5x2T	4
73	Buffer	55308-2-0010-B3	D26*10*M8*1.25	2
74	Upper fixing plate for handle pulse	737L6-6-2491-B0	40*15.2,with LOGO	2
75	Allen bolt	50308-5-0050-F3	M8*1.25*50L	2
76	Allen bolt	50308-5-0055-F3	M8*1.25*55L	1
77	Handle pulse sensor	737L6-6-2478-00	100.3*29.5*0.4T	4
78	Lower fixing plate for handle pulse	737L6-6-2492-B0	40*15.2	2
79	Screw	50904-2-0015-F0	ST4x1.41x15L	2
80	Handle grip	26200-6-1584-B0	D30*3T*710L	1
81	Cross Bolt	52605-2-0010-N0	M5*0.8*10L	7
82	Lower computer cover	264A1-6-1703-B0	793*299*25.3	1
83	Middle computer cover	264A1-6-1711-B0	517.8*395*35	1
84	Computer	264A1-6-1701-B0		1
85L	Left trigger	26200-6-1598-B0	53.3*46.9*14.7	1
85R	Right trigger	26200-6-1599-B0	53.3*46.9*14.7	1
86L	Sticker under left trigger	26200-6-1583-00	66.9*25.4	1
86R	Sticker under right trigger	26200-6-1593-00	66.9*25.4	1
87	Cross screw	52804-2-0012-F0	ST4*1.41*12L	18
88	Trigger base	26200-6-1579-01		2
90	Lower cable of trigger	264D2-6-1582-01	900L	2
91	Allen screw	54010-5-0045-F4	M10*1.5*45L	4
92	Allen bolt	50306-5-0015-UF0	M6*1*15L	4
93	Handpulse cable	261D8-6-1785-00	1000L	2
94	Buffer(2 _x000D_	26100-6-1082-K0	D30*37L*M8,75degree	2
95	Emergency stop pin	26100-6-1731-C1	21*18*1.5T	1
96	Safety key	26200-6-1732-R0	78.6*35*18.2	1
97	Safety clip	26200-6-1793-R0	830L	1
98	Cable for emergency stop function	261D8-6-1736-00	450L	1
99L	Right protecting plate	264A1-3-1130-B0		1
99R	Left protecting plate	264A1-3-1125-B0		1
100	Inner case of safety key	26100-6-1734-B0	39*15*13.3	2

101	Computer fixing plate	264A1-3-1530-J1		1
102	Safety key board	26200-6-1733-B0	74*45*7	1
103	Upper cover for handling tube	264A1-6-1576-B0	836*583*159.3	1
104	Lower cover for handling tube	264A1-6-1577-B0	836*356.8*193.7	1
105L	Side cover for handling tube(left)	264A1-6-1594-B0	417.2*153.3*78	1
105R	Side cover for handling tube(right)	264A1-6-1595-B0	417.2*153.3*78	1
106A	Computer back cover	264A1-6-1748-B0	207.3*188*65.5	1
106B	Computer decorative cover	264A1-6-1749-B0	188*49.2*20.5	1
107L	Left handlebar grips	264A1-6-1571-B0	448.7*126*71	1
107R	Right handlebar grips	264A1-6-1572-B0	448.7*126*71	1
108	Hollow plug	264A1-6-2010-B0	40x80x119	1
109	Flat washer	55105-1-1510-DA	D15*D5.2*1.0T	4
110	Grounding cable 1_x000D_	26100-6-1787-03	325L	1
111	Grounding cable 2_x000D_	264D2-6-1788-00	300L	1
112	live wire 1	261A2-6-1789-00	450L	1
113	live wire 2	26100-6-1790-01	60L	2
114	neutral wire 100L	26100-6-1791-00	100L	1
115	neutral wire 220L	26200-6-1792-00	220L	1
116	Magnetic loop	26100-6-1079-00	D31*16	1
117	Motor decorative cover	264A1-6-2403-Aa0	727.1*40.8*50.1	1
118	Upper cable of trigger	261D8-6-1589-02	500L	1
120	Upper computer cable	264A1-6-1771-00	850L	1
121	Middle computer cable	26200-6-1772-01	1000L	1
122	Lower computer cable	26200-6-1773-00	500L	1
123	Button plate	264A1-6-1756-B0	468*105.4*13.3	1
124	Filter	261D1-6-1067-00	15A	1
125	Inductance	261A2-6-1066-00	15A	1
126	Electric cable	26100-6-1775-02	1700L	1
127	Overlay(LED)	264A1-6-1706-B0	491*296*20	1
129	Allen cross spanner	58030-6-1051-N0	M6*130L	1
130	Allen spanner	58030-6-1052-N0	M8*120L	1
131	Speaker cover	264A1-6-1762-B0		2
132	USB module	264D3-6-1723-00	PA-AB00321-K1	1
133	CSK cross self-tapping screw	51004-2-0010-N0	ST4*1.41*10L	4
134	Cross round-head self-tapping screw	54723-2-0008-C0	ST2.3*8L	27

135	Button PCB board	264A1-6-1759-00		1
137	Inverter	262A3-6-1783-00	RM6T6-2003E1	1
138	neutral wire 450L	261A2-6-1791-00	450L	1
139	Pad of tablet support	264A1-6-1777-B0	409*15*2T	1
140	Cross tube of computer supporting tube	261D8-6-2001-J0	10*20*1.5T*320L	1
141	Cross bolt	52606-2-0015-F0	M6*1*15L	4
142	Allen bolt	50308-5-0015-F0	M8*1.25*15L	4
143	Spring washer	55108-2-1520-FA	D15.4xD8.2x2T	4
144L	Left speaker	261D8-6-1722-01	B00202050,4Ω 3W,cable 300.	1
144R	Right speaker	261D8-6-1761-00	B00202050,4Ω 3W.cable 100.	1
145	Audio cable	81000-6-2555-B0	250L	1
146L	Left plug	264A1-6-1077-B0	D40.7*51.1	1
146R	Right plug	264A1-6-1078-B0	D40.7*51.1	1
147L	Left pad of bottle	264A1 -6-1754-B0	106.5*89.2*3T	1
147R	Right pad of bottle	264A1 -6-1755-B0	106.5*89.2*3T	1
148	Bluetooth module	261D2-6-1708-00	I-RUNNING	1
150	Nut	55208-2-2006-NA	M8*1.25*6T	1
151	Spacer	73800-6-3892-N0	D11.5*D8*3.5T	2
152	Adjustment wheel	26200-6-1095-B0	D27*10L	2
153	Grounding cable (1)	26200-6-1787-00	330L	1
154	Speaker plate	264A1-6-1760-00	8509	1
155	Speaker cable	264A1-6-1763-00	WP-XH-03-XH-03-200L	1
156	Upper cable of LED light	264A1-6-1739-00	800	1
157	Middle cable of LED light	26200-6-1740-01	1100	1
158	Lower cable of LED light	26200-6-1741-00	600	1
159	LED light strap connecting plate	261D1-6-1744-00	PA-AA01170-K5	1
160	PC spacer column	261D1-6-1782-00	D5*D3.5*19.2	4
161	Light strap cable(1)	261D1-6-1742-00	1000	2
162	Light strap	261D1-6-1737-00	LED7 color light strap 135CM	2
168	Elastic rope	264A1-6-2098-B1	D2.5*500L	1
171	Pad holder support	26500-6-1766-B0	271.9*29.8*20.1	1
172	Screw	53335-2-0013-N0	ST3.5*13L	3
A	Fixing hook	26502-6-2097-B0	37.8*100*20.6	1
B	Buffer strap	264A1-6-1084-B0	255*10*2T	1
C	Pad holder	26500-6-1713-B0	271.8*25*20	1

8.3 Exploded Drawing

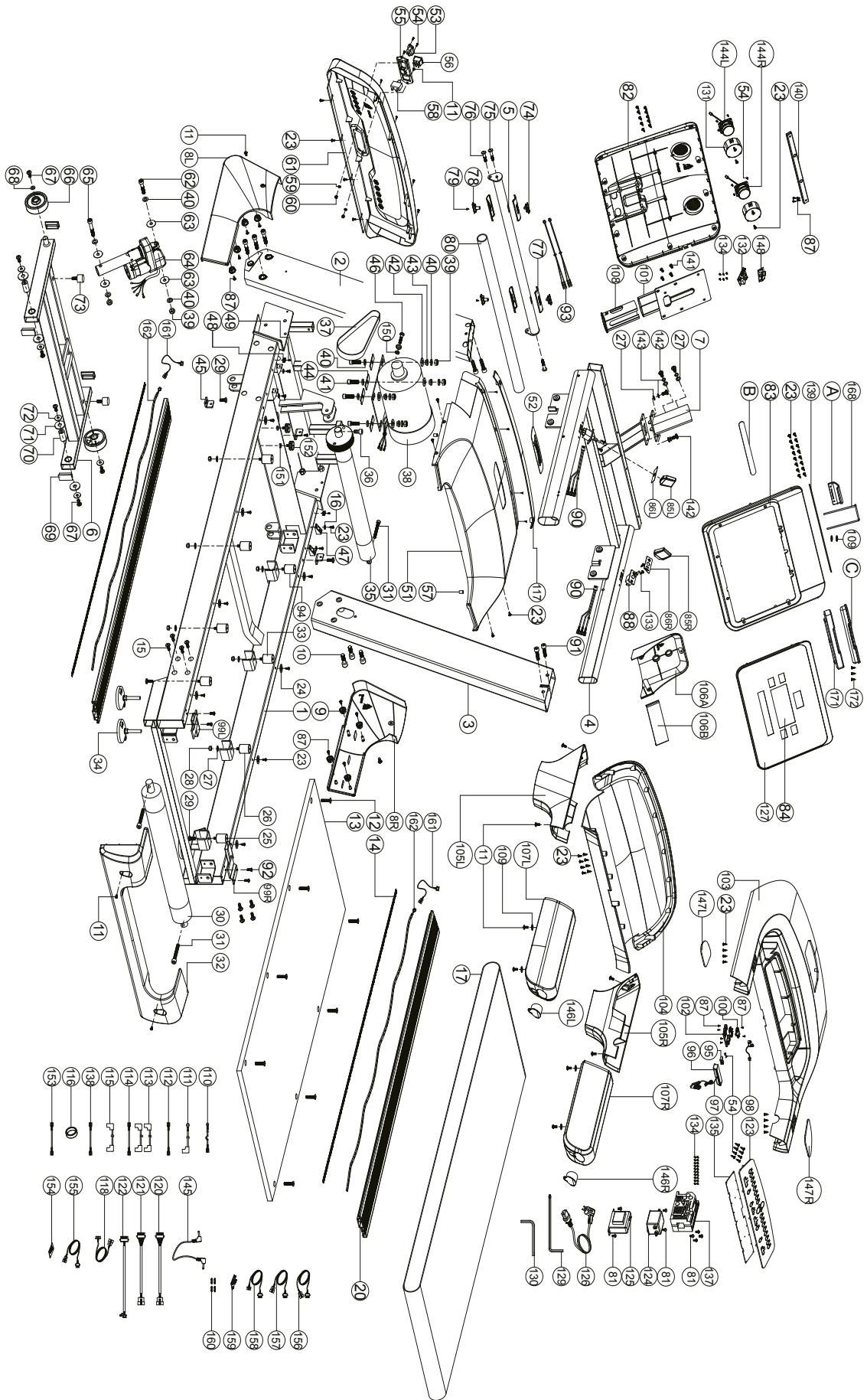

Training equipment from Taurus® is subject to strict quality control. However, if a fitness equipment purchased from us does not work perfectly, we take it very seriously and ask you to contact our customer service as indicated. We are happy to help you by phone via our service hotline.

Error Descriptions

Your fitness equipment is developed for long-term, high-quality training. However, should a problem arise, please first read the operating instructions. For further assistance, please contact your contract partner or call our service hotline. To ensure your problem is solved as quickly as possible, please describe the defect as exactly as possible.

In addition to the statutory warranty, we provide a warranty for every fitness equipment purchased from us according to the following provisions.

Your statutory rights are not affected.

Warranty

The warrantee is the first/original buyer and/or any person who received a newly purchased product as a gift from the original buyer.

Warranty periods

The following warranty periods begin on delivery of the fitness equipment.

Model	Usage	Full Warranty	Frame	Motor
TF-T10.3PRO-3	Home use	24 Months	30 Years	10 Years
	Semi-professional use	12 Months		
	Professional use	6 Months		

Repair Costs

According to our choice, there will either be a repair, a replacement of individual damaged parts or a complete replacement. Spare parts, that have to be mounted while assembling the equipment, have to be replaced by the warrantee personally and are not a part of repair. After the expiration of the warranty period for repair costs, a pure parts warranty applies, which does not include the repair, installation and delivery costs.

The terms of use are defined as follows:

- + Home use: solely for private use in private households up to 3 hours per day
- + Semi-professional use: up to 6 hours per day (e. g. rehabilitation centres, hotels, clubs, company gyms)
- + Professional use: more than 6 hours per day (e. g. commercial gyms)

Warranty Service

Within the warranty period, equipment which develops faults as a result of material or manufacturing defects, will be repaired or replaced at our discretion. Ownership of equipment or parts of equipment which have been replaced is transferred to us. The warranty period is not extended nor does a new warranty period begin following repair or replacement under the warranty.

Warranty Conditions

For the warranty to be valid, the following steps must be taken:

Please contact our customer service by email or phone. If the product under warranty has to be sent in for repair, the seller bears costs. After expiry of the warranty, the buyer bears the costs of transport and insurance. If the fault is covered by our warranty, you will receive a new or repaired equipment in return.

Warranty claims are invalid in case of damage resulting from:

- + misuse or improper handling
- + environmental influences (moisture, heat, electrical surge, dust, etc.)
- + failure to follow the current safety measures for the equipment
- + failure to follow the operating instructions
- + use of force (e. g. hitting, kicking, falling)
- + interventions which were not carried out by one of our authorized service centres
- + unauthorised repair attempts

Proof of Purchase and Serial Number

Please make sure that you are able to provide the appropriate receipt when claiming on your warranty. So that we can clearly identify the model of your equipment, and for the purposes of our quality control, you will need to give the serial number of your equipment, when contacting the service team. Where possible please have your serial number and your customer number ready when you call our service hotline. It will help us to deal with your request swiftly.

If you cannot find the serial number on your fitness equipment, our service team is at your disposal to offer further information.

Service outside of the Warranty Period

We are also happy to issue an individual cost estimate if there is a problem with your fitness equipment after the warranty has expired, or in cases which do not fall under the terms of the warranty, e. g. normal wear and tear. Please contact our customer service team to find a quick and cost-effective solution to your problem. In such a case you will be responsible for the delivery costs.

Communication

Many problems can be solved just by speaking to us as your specialist supplier. We know how important it is to you as a user of the fitness equipment to have problems solved quickly and simply, so you can enjoy working out with minimal interruption. For that reason, we also want to resolve your queries quickly and in a straightforward manner. Thus, please always keep your customer number and the serial number of the faulty equipment handy.

DE	DK	FR
<p>TECHNICAL SUPPORT</p> <p>☎ +49 4621 4210-900 📠 +49 4621 4210-698 ✉ technik@sport-tiedje.de</p> <p>🕒 Mo - Fr 08:00 - 18:00 Sa 09:00 - 18:00</p> <p>SERVICE</p> <p>☎ 0800 20 20277 (Freecall)</p> <p>✉ info@sport-tiedje.de</p> <p>🕒 Mo - Fr 08:00 - 21:00 Sa 09:00 - 21:00 So 10:00 - 18:00</p>	<p>TECHNICAL SUPPORT & SERVICE</p> <p>☎ 80 90 16 50 +49 4621 4210-945 ✉ info@fitshop.dk</p> <p>🕒 Mo - Fr 08:00 - 18:00 Sa 09:00 - 18:00</p>	<p>TECHNICAL SUPPORT & SERVICE</p> <p>☎ +33 (0) 172 770033 +49 4621 4210-933 ✉ service-france@fitshop.fr</p> <p>🕒 Mo - Fr 08:00 - 18:00 Sa 09:00 - 18:00</p>
	PL	BE
	<p>TECHNICAL SUPPORT & SERVICE</p> <p>☎ 22 307 43 21 +49 4621 42 10-948 ✉ info@fitshop.pl</p> <p>🕒 Mo - Fr 08:00 - 18:00 Sa 09:00 - 18:00</p>	<p>TECHNICAL SUPPORT & SERVICE</p> <p>☎ 02 732 46 77 +49 4621 42 10-932 ✉ info@fitshop.be</p> <p>🕒 Mo - Fr 08:00 - 18:00 Sa 09:00 - 18:00</p>

UK	NL	INT
<p>TECHNICAL SUPPORT</p> <p>☎ +44 141 876 3986 ✉ support@powerhousefitness.co.uk</p> <p>SERVICE</p> <p>☎ +44 141 876 3972 🕒 Mo - Fr 9am - 5pm</p>	<p>TECHNICAL SUPPORT & SERVICE</p> <p>☎ +31 172 619961 ✉ info@fitshop.nl</p> <p>🕒 Ma - Do 09:00 - 17:00 Vr 09:00 - 21:00 Za 10:00 - 17:00</p>	<p>TECHNICAL SUPPORT & SERVICE</p> <p>☎ +49 4621 4210-944 ✉ service-int@sport-tiedje.de</p> <p>🕒 Mo - Fr 8am - 6pm Sat 9am - 6pm</p>
	AT	CH
	<p>TECHNICAL SUPPORT & SERVICE</p> <p>☎ 0800 20 20277 (Freecall) +49 4621 42 10-0 ✉ info@sport-tiedje.at</p> <p>🕒 Mo - Fr 08:00 - 18:00 Sa 09:00 - 18:00</p>	<p>TECHNICAL SUPPORT & SERVICE</p> <p>☎ 0800 202 027 +49 4621 42 10-0 ✉ info@sport-tiedje.ch</p> <p>🕒 Mo - Fr 08:00 - 18:00 Sa 09:00 - 18:00</p>

Please find a detailed overview including address and opening hours for all stores of the Sport-Tiedje Group in Germany and abroad on the following website:

www.sport-tiedje.com/en/stores

WE LIVE FITNESS

WEBSHOP AND SOCIAL MEDIA

Sport-Tiedje is Europe's largest specialist store for home fitness equipment with currently 80 stores and one of the world's most renowned online mail order companies for fitness equipment. Private customers order via the 25 web shops in the respective national language or have their desired equipment assembled on site. In addition, the company supplies fitness studios, hotels, sports clubs, companies and physio practices with professional equipment for endurance and strength training.

Sport-Tiedje offers a wide range of fitness equipment from renowned manufacturers, high-quality in-house developments and comprehensive services, such as a build-up service and sports scientific advice before and after the purchase. The company employs numerous sports scientists, fitness trainers and competitive athletes.

Visit us also on our social media platforms or our blog!

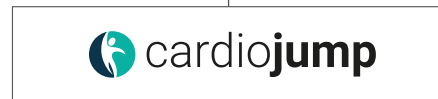
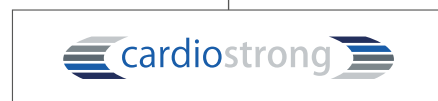
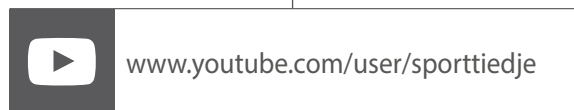
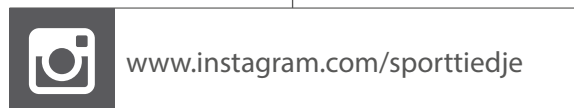
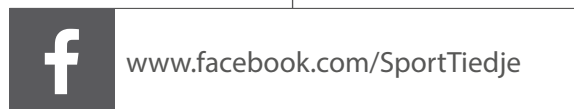

TAURUS®

Treadmill T10.3 Pro