

TAURUS®

Operating Instructions

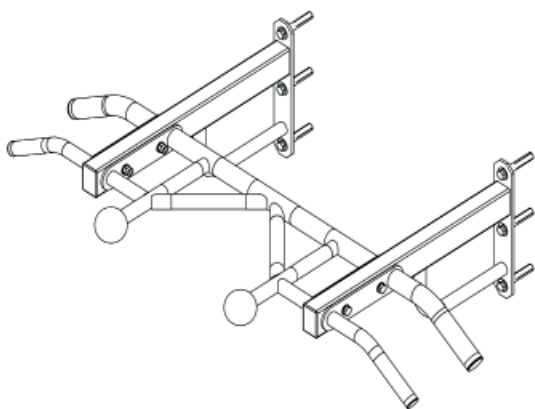

FSTFPU1207HT.01.02

Art. No. TF-PU1207HT

Specification

The Taurus chin-up bar Premium is a solid chin-up bar for wall mounting that offers various different grip positions. Upper grip, lower grip or parallel hand position - the chin-up bar offers all grip variations, as well as special ball grips/climbing grips that are particularly well suited to additionally improve the forearm muscles and grip strength. As a special highlight, the wide pull-up bars are available with two different grip diameters.

The pull-up bar can be loaded with up to 120 kg (please also note the wall condition).

- + Chin-up bar with many grip positions
- + Very solid steel construction
- + Wide chin-up grip with two different grip diameters possible
- + Incl. two ball handles | climbing handles
- + With angled, parallel and straight handles in different grip widths
- + Several ways to attach support straps or a sling trainer

Technical Data

Packaging dimensions (L x W x H):	65 cm x 49 cm x 13 cm
Weight (gross, incl. packaging):	14 kg
Max. load approx.:	120 kg

Assembly

Before assembly, take a close look at the individual assembly steps shown and carry out the assembly in the order given.

① NOTICE

First loosely screw all parts together and check that they fit properly. Tighten the screws using the tool only when you are instructed to do so.

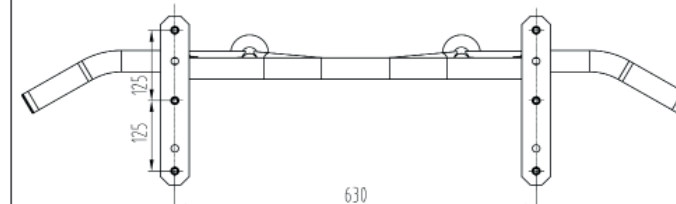
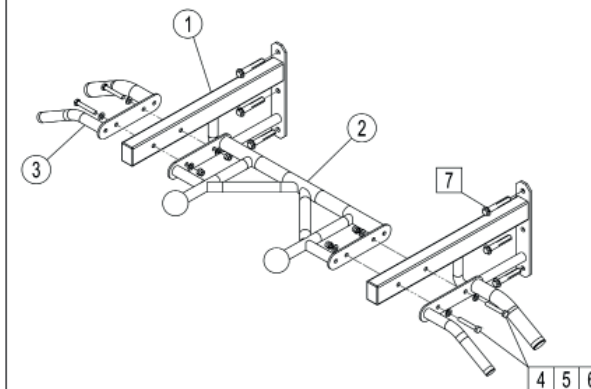

No.	Description	Qty.
1	Side Frame	2
2	Big Handle	1
3	Small Handle	2
4	Bolt M10*65	4
5	Washer 10	8
6	Lock Nut M10	4
7	Expansion Bolt Set	6

Assemble both side frames (1) and both small handles (3) to the big handle (2) by using two bolts (4), four washers (5) and two lock nuts (6) on each side.

Wall Assembly

► ATTENTION

The supplied assembly material for wall mounting is not suitable for every wall. Pay attention to the condition of your wall to determine which assembly material is suitable for your wall.

The contractual partner accepts no liability for any damage to the wall. Make sure that there are no cables or wires running in the wall where you attach the training equipment.

📌 NOTICE

The supplied assembly material is not suitable for every wall, so you may need to get assembly material that is suitable for your wall.

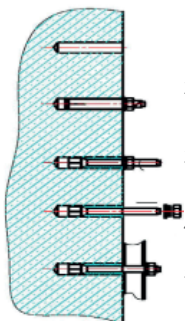

1. Drill a hole with a minimum depth of 80mm.
2. Insert the expansion screw (with cover) into the hole.
3. Tighten the nut, causing the bolt to unscrew and the inside to spread and fix itself into the wall.
4. Unscrew the nut.
5. Slide the wall support on the bolt and fix it with the previously unscrewed nut.

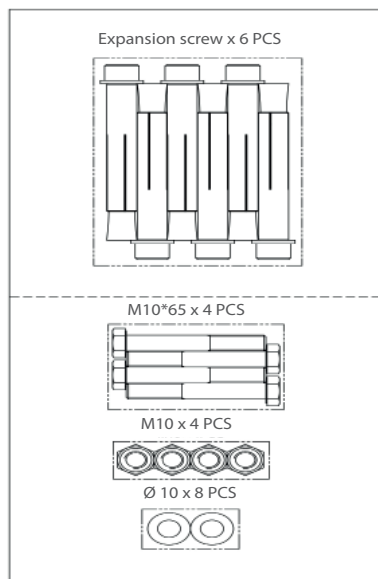

General Safety Instructions

⚠️ DANGER

- + Before you start using the equipment, you should consult your physician that this type of exercise is suitable for you from a health perspective.
- + Note that excessive training can seriously endanger your health. If you notice any signs of weakness, nausea, dizziness, pain, shortness of breath, or other abnormal symptoms, stop exercising immediately and seek advice from your doctor if necessary.

⚠️ WARNING

- + This equipment may not be used by children under 14 years.
- + Children should not be allowed unsupervised access to the equipment
- + Persons with disabilities must have a medical license and must be under strict observation when using the equipment.
- + The equipment is strictly for use by one person at a time.

⚠️ CAUTION

- + Make sure that nobody is within the range of motion of the equipment during training so as not to endanger you or other persons.

► ATTENTION

- + Do not insert any objects of any kind into the openings of the device.

Care, Maintenance and Storage

⚠️ WARNING

The storage location should be chosen so that improper use by third parties or children can be prevented.

1. Clean the device with a dry soft cloth.
2. Store the device in the supplied carton in a dry environment.

Warranty Information

Training equipment from TAURUS® is subject to strict quality control. However, if a fitness equipment purchased from us does not work perfectly, we take it very seriously and ask you to contact our customer service as indicated. We are happy to help you by phone via our service hotline.

Warranty period

The warranty periods, shown on our web shop, begin on delivery of the fitness equipment. The respective warranty periods for your equipment can be found on its product website.

Contact

DE TECHNIK

☎ +49 4621 4210-900

✉ technik@fitshop.de

SERVICE

☎ 0800 20 20277 (kostenlos)

✉ info@fitshop.de

UK CUSTOMER SUPPORT

☎ 00800 2020 2772

+494621 4210 944

✉ info@fitshop.co.uk

FR TECHNIQUE & SERVICE

☎ +33 (0) 189 530984

+49 4621 42 10 933

✉ info@fitshop.fr

DK TEKNIK OG SERVICE

☎ 80 90 16 50

+49 4621 4210-945

✉ info@fitshop.dk

ES TECNOLOGÍA Y SERVICIOS

☎ 911 238 029

✉ info@fitshop.es

BE TECHNIQUE & SERVICE

☎ 02 732 46 77

+49 4621 4210 933

✉ info@fitshop.be

NL TECHNISCHE DIENST & SERVICE

☎ +31 172 619961

✉ service@fitshop.nl

AT TECHNIK & SERVICE

☎ 0800 20 20277 (kostenlos)

+49 4621 42 10-0

✉ info@fitshop.at

CH TECHNIK & SERVICE

☎ 0800 202 027

+49 4621 42 10-0

✉ info@fitshop.ch

PL DZIAŁ TECHNICZNY I SERWIS

☎ 22 307 43 21

+49 4621 42 10-948

✉ info@fitshop.pl

INT TECHNICAL SUPPORT & SERVICE

☎ +49 4621 4210-944

✉ service-int@fitshop.de