

TAURUS®

RK1458 TAURUS LANGHANTELABLAGE X2 PRO

TF-RK1458

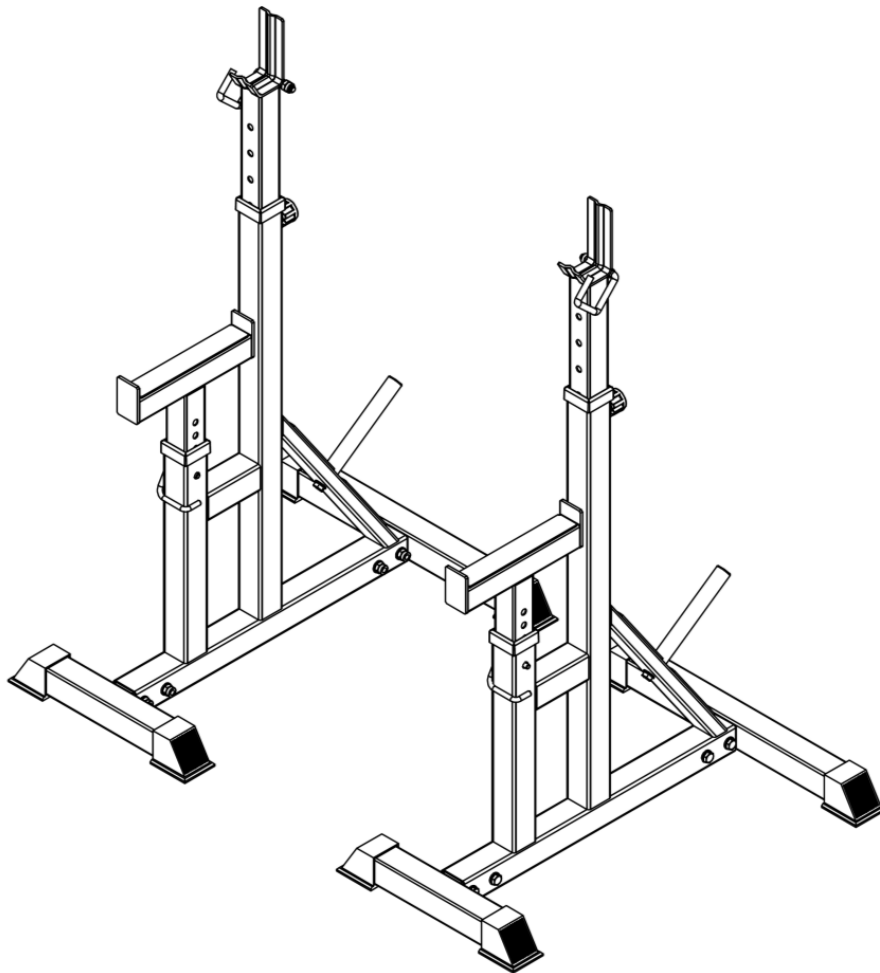

ASSEMBLY INSTRUCTIONS

SAFETY PRECAUTION

Safety First

Regardless of how enthusiastic you may be about getting on your equipment and exercising, take the time to ensure that your safety is not jeopardized. A moment's lack of attention can result in an accident, as can failure to observe certain simple safety precautions.

1. Assemble the equipment according to the assembly instructions and only use the individual parts enclosed for assembly of the equipment and which are listed in the parts list as being specifically for this equipment. Before you start assembly, check against the delivery to make sure that everything has been delivered and check against the packing list to make sure all parts have been enclosed.
2. Read, study and understand the Owner's Manual and all the warning labels on this product. Furthermore, it is recommended to familiarize yourself and others with the proper operation and workout recommendations for this product prior to use. Some of this information can be obtained in this owner's Manual, as-well-as from your local retailer.
3. It is imperative that you retain this Owner's Manual and be sure all warning labels are legible and intact. Replacements Owner's Manual and labels are available from your local retailer.
4. It is recommended that another person assist you with the assembly this unit.
5. Consult with your physician before beginning any exercise program. It is recommended that you undergo a complete physical examination.
6. Use proper discretion when children are present.
7. Frayed or worn cables can be dangerous and may cause injury. Periodically check these cables for any indication of wear.
8. Keep hands, limbs, loose clothing and long hair well out of the way of moving parts.
9. Do not attempt to lift more weight than you can control safely.
10. Work within your recommended exercise level. DO NOT work to exhaustion. If you feel any pain or discomfort, stop your workout immediately.
11. Inspect the machine for any sign of wear on parts, hardware becoming loose or cracks on welds. If a problem is found do not use or allow the machine to be used until the defective part is repaired or replaced.
12. DO NOT place any sharp objects around the machine.

ASSEMBLY INSTRUCTION

I . Notice of assembly

- * An enough dimension will be required to assemble and properly use the machine.
- * Please use floor padding, such as cardboard, to avoid scratching your floor during assembly.
- * The nuts and bolts have a little grease on them to protect them from corrosion. Please keep a rag handy to wipe your hands.
- * All plastic end caps and plugs have been assembled on the unit prior to shipment. They are shown on the assembly drawings for reference in the event replacement parts are needed.
- * The machine uses several different lengths of bolts. Be careful to use the correct length of bolt called for at each step of assembly.
- * Do not touch the wires and cables attention when drilling.

II . Before you begin

Locate a comfortable work site. Assemble your machine in an open space with ventilation and lighting, and with the help of other person. The machine posses a large area, so you do not place it in living room.

Find your tools. You will need the following tools to assemble your machine.

- . Standard screwdriver
- . WD40 lubricant or Vaseline (if necessary)

Review all safety guideline on Page 2 of this manual.

III . Assembling your machine

EXPLODED DRAWING

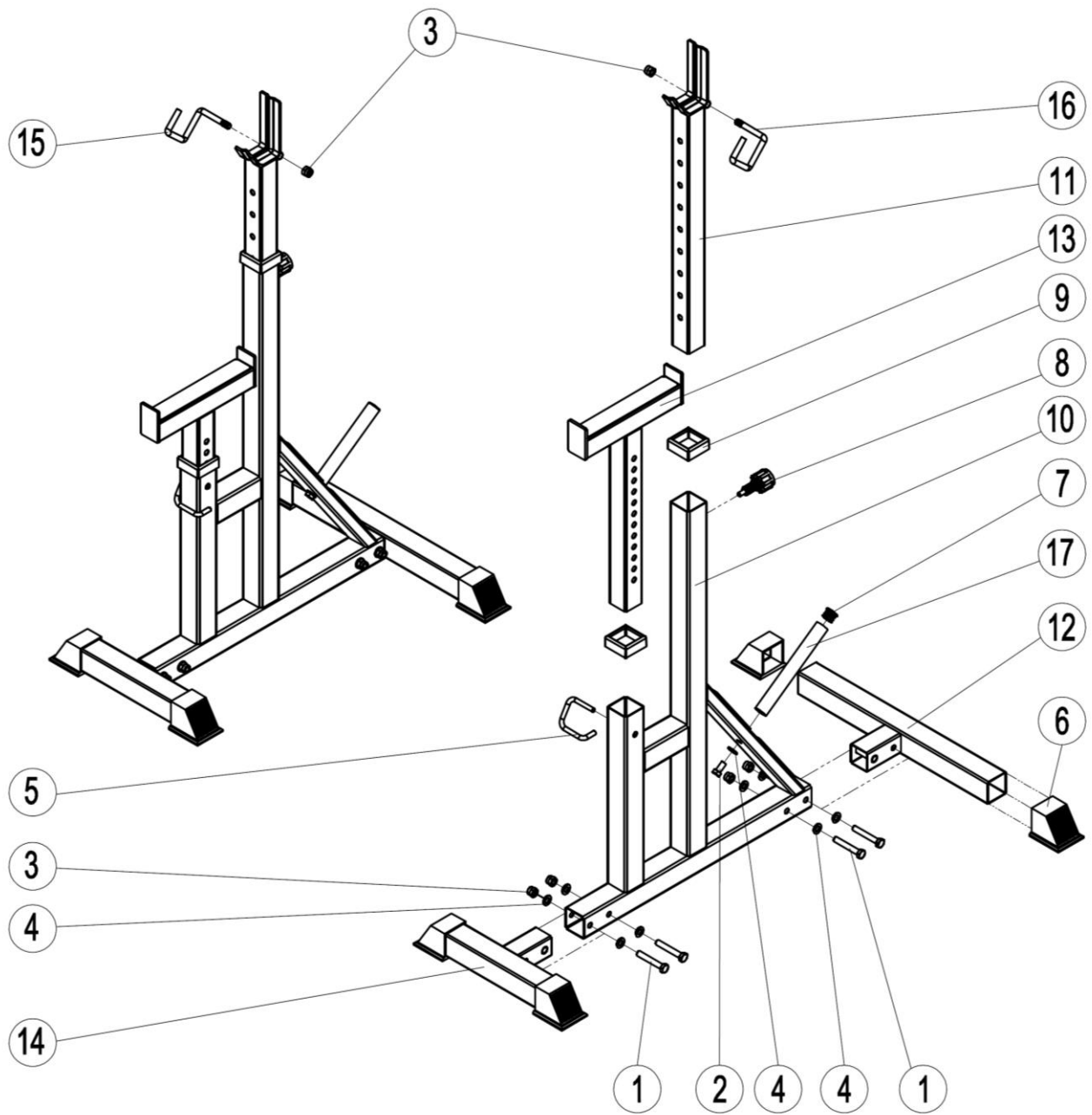

PART LIST

NUMBER	DESCRIPTION	QUANTITY
1	M10*65 BOLT	8
2	M10*20 BOLT	2
3	M10 LOCK NUT	10
4	M10 WASHER	18
5	LOCK CATCH	2
6	FOOT COVER	8
7	TUBE PLUG	2
8	M16 POPPER PIN	2
9	5045 PLASTIC TUBE BUSHING	4
10	MAIN FRAME	2
11	HEIGHT ADJUSTING BAR	2
12	BACK FRAME BASE	2
13	SAFETY BAR	2
14	FRONT FRAME BASE	2
15	RIGHT BARBELL LOCK	1
16	LEFT BARBELL LOCK	1
17	PLATE STORAGE	2

ASSEMBLY STEPS

STEP 01

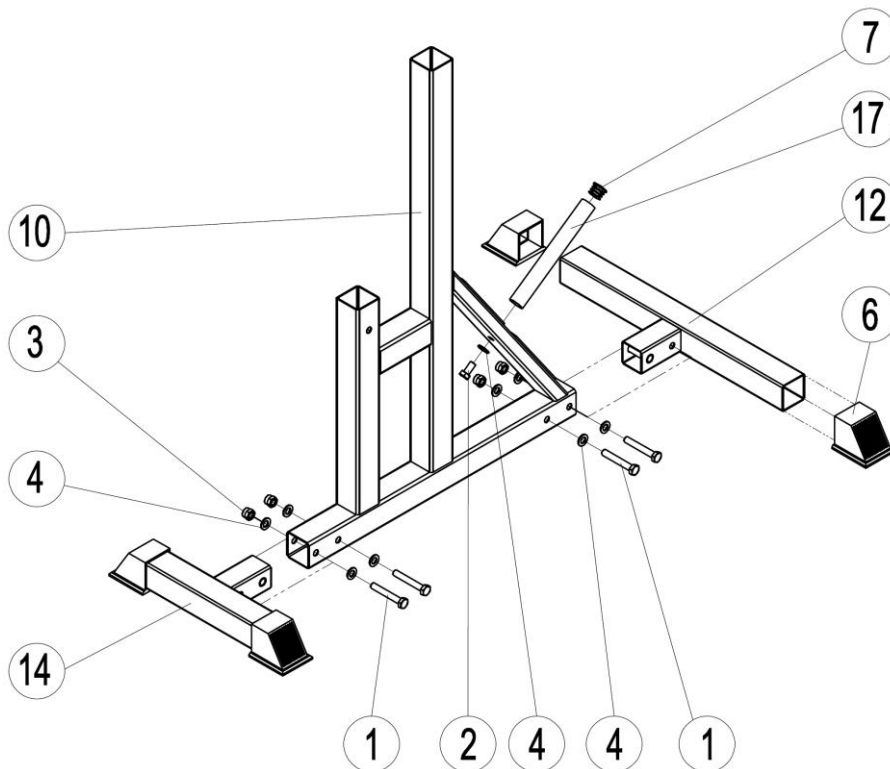

A. Attach two Foot Covers (6) to Front Base Frame (14), and attach two Foot Covers (6) to Back Base Frame (12).

B. Attach Front Base Frame (14) to Main Frame (10) and secure using two M10 x 65 Bolts (1), four M10 Washers (4) and two M10 Lock Nuts (3). Base is expandable so choose the depth you would like the base to be and secure accordingly.

C. Attach Back Base Frame (12) to Main Frame (10) and secure using two M10 x 65 Bolts (1), four M10 Washers (4) and two M10 Lock Nuts (3). Base is expandable so choose the depth you would like the base to be and secure accordingly. Firmly tighten all hardware.

D. Attach the Round Plug (7) to Plate Storage (17), and attach Plate Storage (17) to the back of the Main Frame (10) using the M10 x 20 Bolt (2), M10 Washer (4) . Do this for both stands.

STEP 02

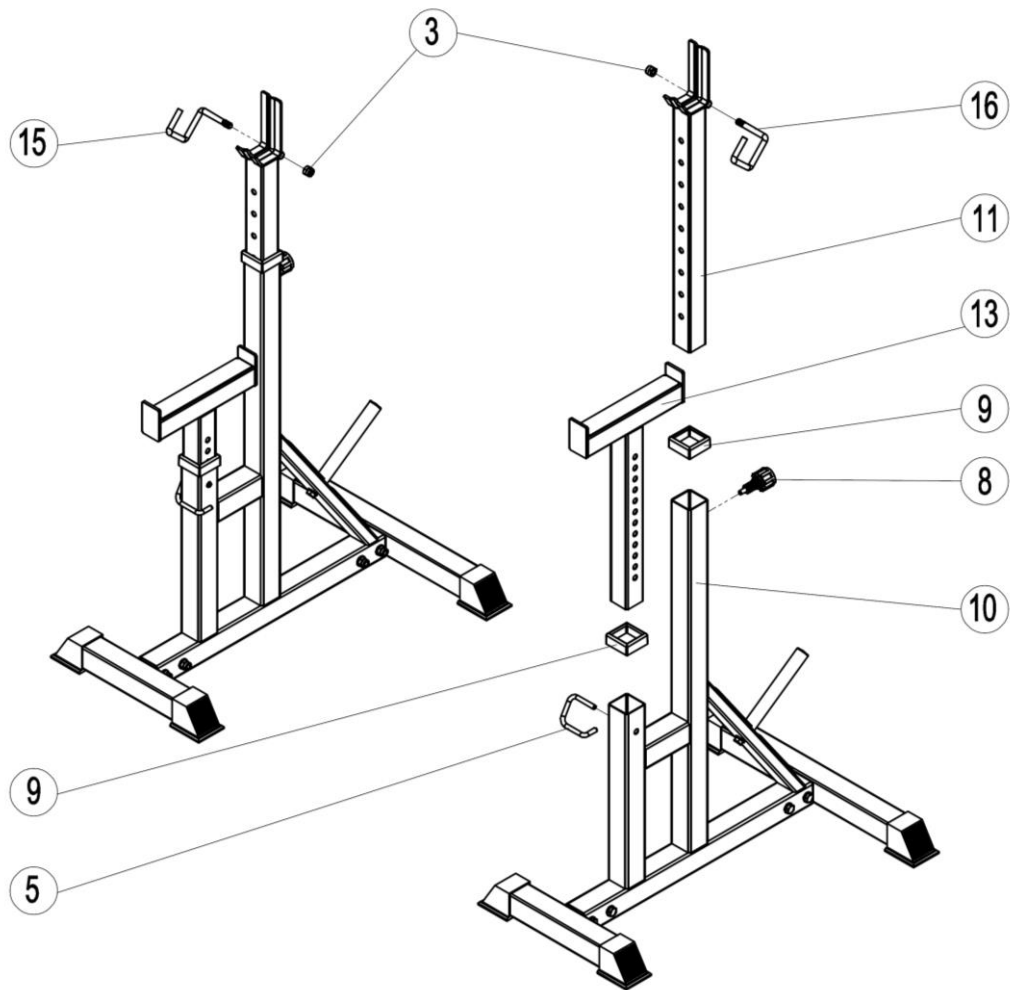

- A. Attach two 5045 Plastic Tube Bushings (9) to each Main Frame (10).
 - B. Insert the Height Adjusting Bar (11) into the Main Frame (10) by using M16 Popper Pin (8). Do this for both stands.
 - C. Insert the Safety Bar (13) into the Main Frame (10) by using the Lock Catch (5). Do this for both stands.
 - D. Secure the Left and Right Barbell Locks (16,15) through the top of the Height Adjusting Bar (11) with an M10 Lock Nut (3).
- Do all steps for both stands.

RD. 2015-08-06 R0