

TAURUS®

Assembly and Operating Instructions

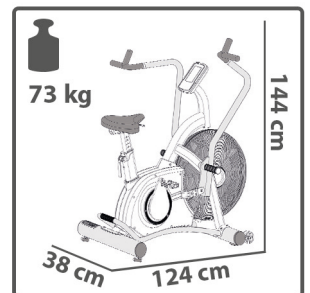
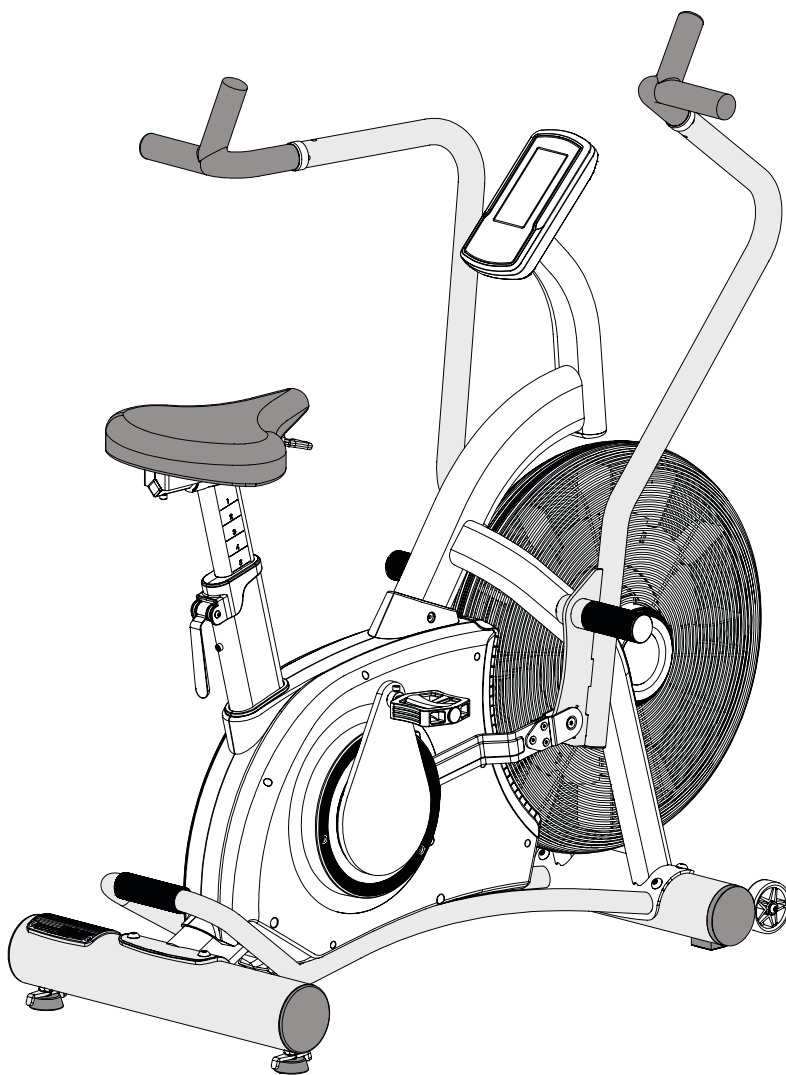

TFERGOX.01.05

Content

1	GENERAL INFORMATION	7
1.1	Technical Data	7
1.2	Personal Safety	8
1.3	Set-Up Place	9
2	ASSEMBLY	10
2.1	General Instructions	10
2.2	Scope of Delivery	11
2.3	Assembly	12
2.4	Further Information	16
2.4.1	Adjusting the seat post and saddle	16
2.4.2	Changing the batteries	16
3	OPERATING INSTRUCTIONS	17
3.1	Console Display	17
3.2	Button Functions	19
3.3	Turning on and off the equipment	20
3.4	Programmes	22
3.4.1	Quick Start	22
3.4.2	Interval 20-10 Mode	24
3.4.3	Interval 10-20 Mode	25
3.4.4	Interval Custom mode	26
3.4.5	Target Time Mode	28
3.4.6	Target Distance Mode	29
3.4.7	Target Calories Mode	30
3.4.8	Target HR Mode	31
4	STORAGE AND TRANSPORT	32
4.1	General Instructions	32
4.2	Transportation Wheels	32
5	TROUBLESHOOTING, CARE AND MAINTENANCE	33
5.1	General Instructions	33
5.2	Faults and Fault Diagnosis	33
5.3	Maintenance and Inspection Calendar	34
6	DISPOSAL	34
7	RECOMMENDED ACCESSORIES	35

8	ORDERING SPARE PARTS	36
8.1	Serial Number and Model Name	36
8.2	Parts List	37
8.3	Exploded Drawing	39
9	WARRANTY	40
10	CONTACT	42

Dear customer,

Thank you for choosing a high-quality equipment of the brand Taurus®. Taurus® offers sports and fitness equipment for the sophisticated home sport and the equipment of fitness studios and business customers. With Taurus® fitness equipment, the focus is on what sport is all about: maximum performance! Therefore, the equipment is developed in close consultation with athletes and sports scientists. Because athletes know best what makes perfect fitness equipment.

Further information can be found at www.sport-tiedje.com.

Intended Use

The equipment may only be used for its intended purpose.

This fitness equipment is suitable for home use, semi-professional use and commercial or professional use. The semi-professional sector includes, for example, institutional facilities such as hospitals, schools, hotels and associations. Professional use refers to commercial use, e.g. in a fitness studio.

Legal Notice

Sport-Tiedje GmbH
Europe's No. 1 for home fitness

International Headquarters
Flensburger Straße 55
24837 Schleswig
Germany

Management:
Christian Grau
Sebastian Campmann
Dr. Bernhard Schenkel
No. HRB 1000 SL
Local Court Flensburg
European VAT Number: DE813211547

Disclaimer



©2010 Taurus® is a registered brand of the company SportTiedje GmbH. All rights reserved. Any use of this trademark without the explicit written permission of Sport-Tiedje is prohibited.

Product and manual are subject to change. Technical data can be changed without advance notice.

ABOUT THIS MANUAL

Please carefully read the entire manual before installation and first use. The manual will help you to quickly set up the system and explains how to safely use it. Make sure that all persons exercising with the equipment (especially children and persons with physical, sensory, mental or motor disabilities) are informed about this manual and its contents in advance. In case of doubt, responsible persons must supervise the use of the equipment.



This equipment has been manufactured according to the latest safety knowledge. As far as possible, potential safety hazards which could cause injury have been eliminated. Make sure to carefully follow the instructions and that all parts are securely in place. If required, read through the instructions again to correct any mistakes.

Please pay close attention to the safety and maintenance instructions given here. The contract partner cannot be held liable for damage to health, accidents or damage to the equipment when it is not used in accordance with these instructions.

The following safety instructions may appear in this manual:

► **ATTENTION**

This notice indicates potentially hazardous situations which, if not avoided, may result in property damage.

⚠ **CAUTION**

This notice indicates potentially hazardous situations which, if not avoided, may result in slight or minor injuries!

⚠ **WARNING**

This notice indicates potentially hazardous situations which, if not avoided, may result in death or serious injuries!

⚠ **DANGER**

This notice indicates potentially hazardous situations which, if not avoided, will result in death or serious injuries!

ⓘ **NOTICE**

This notice indicates further useful information.

Retain these instructions in a safe place for future reference, maintenance or when ordering replacement parts.

1.1 Technical Data

LCD display of

- + training distance in km
- + calories burnt in kcal
- + heart rate (when using the hand sensors or a chest strap)
- + Watt
- + cadence (rotations per minute)
- + speed in km/h
- + training time in min
- + Target heart rate

Resistance system: Air resistance system

Total number of training programs:	8
User defined programs:	1
Quick Start program:	1
Target programs:	3
Interval programs:	2
Heart rate controlled programs:	1

Weight and dimensions:

Article weight (gross, including packaging): 80 kg

Article weight (net, without packaging): 72,4 kg

Package dimensions (L x W x H): approximately 1320 mm x 370 mm x 870 mm

Set-up dimensions (L x W x H): approximately 1240 mm x 380 mm x 1440 mm

Maximum user weight: 160 kg / 352 lbs

1.2 Personal Safety

DANGER

- + Before you start using the equipment, you should consult your physician that this type of exercise is suitable for you from a health perspective. Particularly affected are persons who: have a hereditary disposition to high blood pressure or heart disease, are over the age of 45, smoke, have high cholesterol values, are overweight and/or have not exercised regularly in the past year. If you are under medical treatment that affects your heart rate, medical advice is absolutely essential.
- + Note that excessive training can seriously endanger your health. Please also note that heart rate monitoring systems can be inaccurate. If you notice any signs of weakness, nausea, dizziness, pain, shortness of breath, or other abnormal symptoms, stop exercising immediately and seek advice from your doctor if necessary.

WARNING

- + This equipment may not be used by children under the age of 14.
- + Children should not be allowed unsupervised access to the equipment.
- + Persons with disabilities must have a medical license and must be under strict observation when using the equipment.
- + The equipment is strictly for use by one person at a time.
- + Keep your hands, feet and other body parts, hair, clothing, jewellery and other objects well clear of moving parts.
- + During use, wear suitable sports clothing rather than loose or baggy clothing. When wearing sports shoes, make sure they have suitable soles, preferably made of rubber or other non-slip materials. Shoes with heels, leather soles, studs or spikes are unsuitable. Never exercise barefoot.

CAUTION

- + If your equipment needs to be connected to the power supply with a mains cable, make sure that the cable is not a potential tripping hazard.
- + Make sure that nobody is within the range of motion of the equipment during training so as not to endanger you or other persons.

ATTENTION

- + Do not insert any objects of any kind into the openings of the device.

1.3 Set-Up Place

WARNING

- + Do not place the equipment in main corridors or escape routes.

CAUTION

- + Choose a location in which to place the equipment such that there is enough free space/clearance to the front, the rear and to the sides of the equipment. Make sure that you leave at least 30 cm on each side of the equipment and at least 15 cm in front of and behind the equipment as a training zone. This is the minimum required area in order to safely use the equipment. The recommended free zone around the equipment should be at least 60 cm on each side and 45 cm in front of and behind the equipment.
- + The training room should be well ventilated during training and not be exposed to any draughts.
- + Choose the place in which to set up the equipment such that there is enough free space/clearance to the front, the rear and to the sides of the equipment.
- + The set-up and mounting surface of the equipment should be flat, loadable and solid.

ATTENTION

- + The device may only be used in one building, in sufficiently tempered and dry rooms (ambient temperatures between 10°C and 35°C). The equipment should not be used outdoors or in rooms with high humidity (over 70%) like swimming pools.
- + A floor protective mat/equipment underlay can help to protect high-quality floor coverings (parquet, laminate, cork, carpets) from dents and sweat and can help to level out slight unevenness.

2.1 General Instructions



DANGER

- + Do not leave any tools, packaging materials such as foils or small parts lying around, as otherwise there is a danger of suffocation for children. Keep children away from the equipment during assembly.



WARNING

- + Pay attention to the instructions attached to the equipment in order to reduce the risk of injuries.



CAUTION

- + Do not open the packaging when it is lying on its side.
- + Ensure to have sufficient room for movement in each direction during assembly.
- + The assembly of the equipment must be carried out by at least two adults. If in doubt, seek the help of a third technically skilled person.



ATTENTION

- + To prevent damage to the equipment and the floor, assemble the equipment on a mat or packaging board.



NOTICE

- + In order to make the assembly as simple as possible, some screws and nuts to be used can already be pre-assembled.
- + Ideally, assemble the equipment at its later set-up place.

2.2 Scope of Delivery

The scope of delivery consist of the following parts. At the beginning, check whether all parts and tools belonging to the device are included in the scope of delivery and whether damage has occurred. In the event of complaints, the contractual partner must be contacted directly.

⚠ CAUTION

If parts of the scope of delivery are missing or damaged, the assembly must not be carried out.

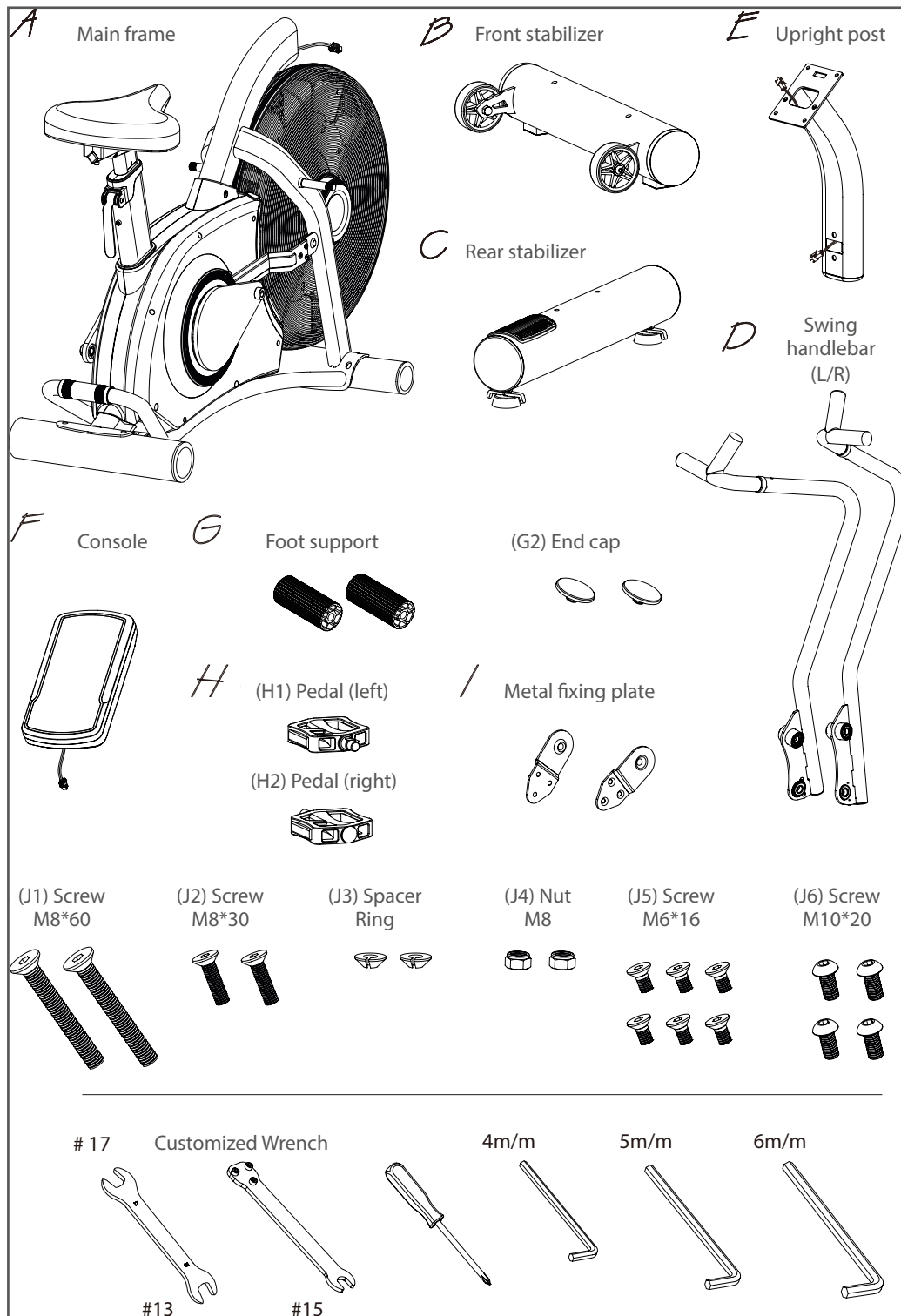

2.3 Assembly

Before assembly, take a close look at the individual assembly steps shown and carry out the assembly in the order given.

① NOTICE

First loosely screw all parts together and check that they fit properly. Tighten the screws using the tool only when you are instructed to do so.

Step 1: Assembly of front stabilizer

1. Loosen both screws (J6) from the cardboard roll. The paper tube serves as packaging protection and is not required for or after the assembly.
2. Mount the front stabilizer (B) with the screw (J6) on the main frame (A). Screw the adjusting screws in or out to compensate potential unevenness of the floor.

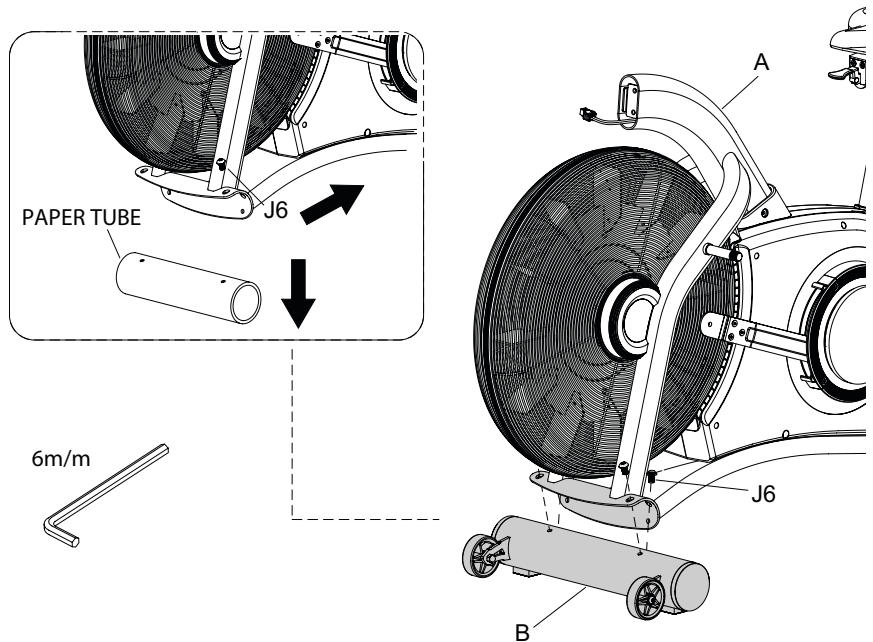

Step 2: Assembly of rear stabilizer

1. Loosen both screws (J6) from the paper tube. The cardboard roll serves as packaging protection and is not required for or after the assembly.
2. Mount the rear stabilizer (C) with the screw (J6) on the main frame (A).

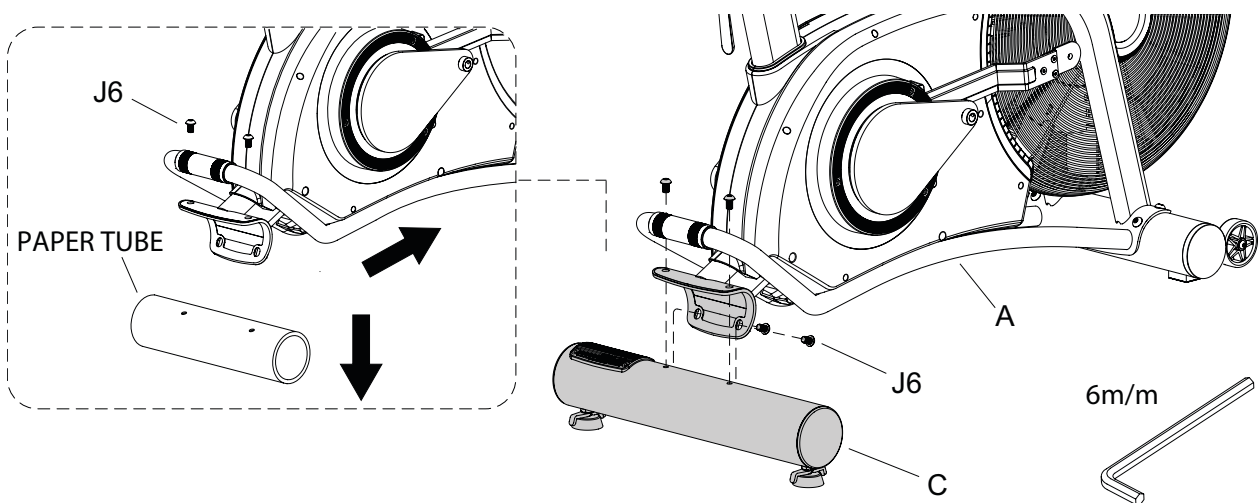

Step 3: Assembly of left and right arm bar & footrest

1. Mount the right, swinging handlebar (D2) with a spacer ring (J8) on the main frame (A).
2. Mount the foot support (G) then. Fix the footrest with the wrench and put an end cap (G2) on it.
3. Mount the foot support clockwise with the wrench.

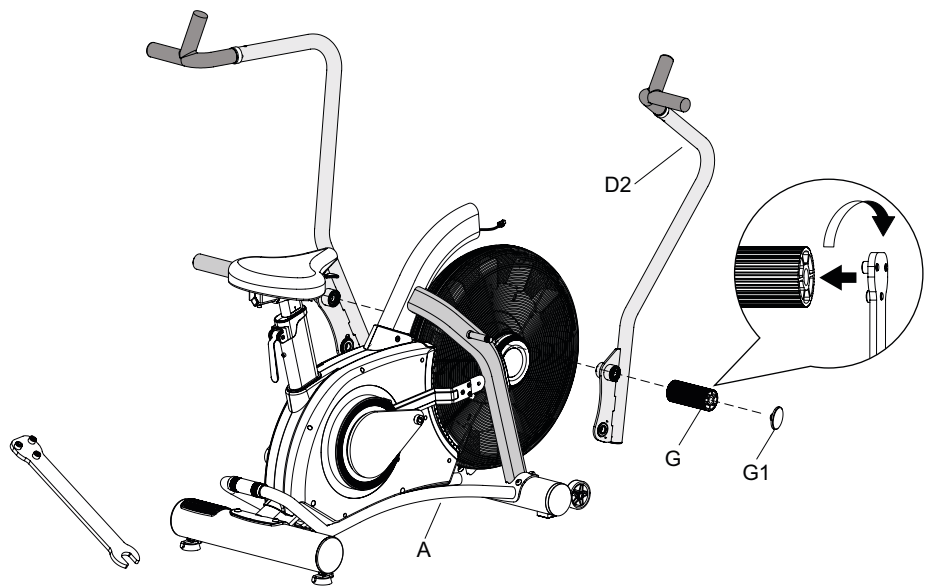

Step 4: Assembly of metal fixing plate

1. Mount the metal fixing plate (I) on the right swinging handlebar (D2). Use the connecting rod (A17), the screws (J2), the spacer ring (J3), the nut (J4), and the screws (J5).
2. Tighten the screws.
3. Do the same on the left side.

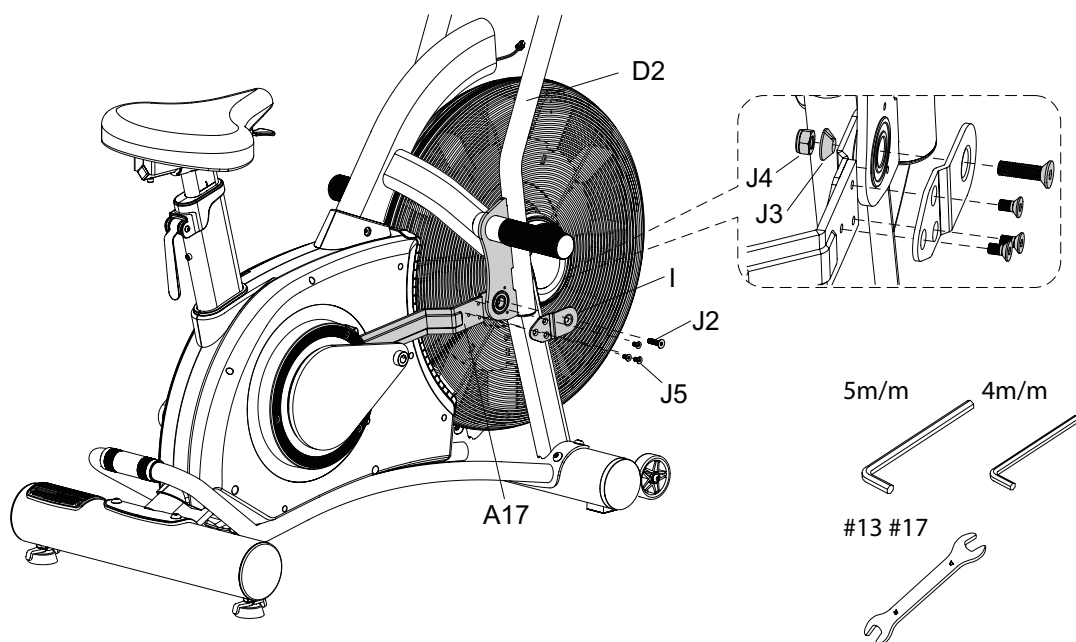

Step 5: Assembly of pedals

1. Loosen the screw (J7) from the crank (A8).
2. Mount the right pedal (H2) on the crank (A8) and mount it with the Allen wrench and the wrench.
3. Tighten the screw (J7) on the crank. Do the same on the left side.

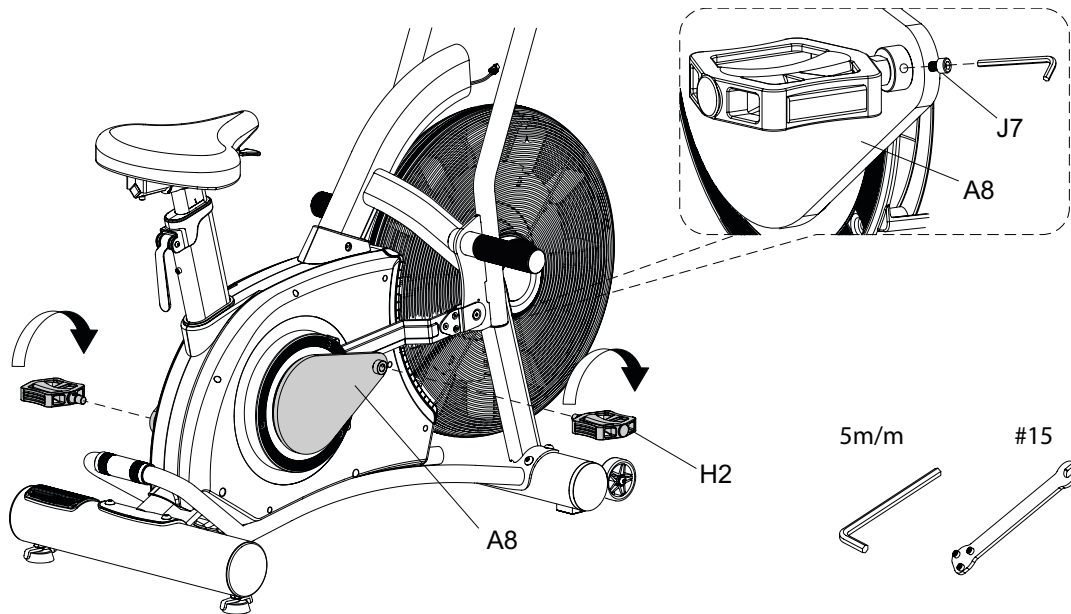

Step 6: Assembly of upright post

► ATTENTION

Please make sure that the sensor cables are not damaged during the assembly.

1. Connect the cables (E1) and (A30).
2. Mount the upright post (E) with the screw (J1) on the main frame (A).

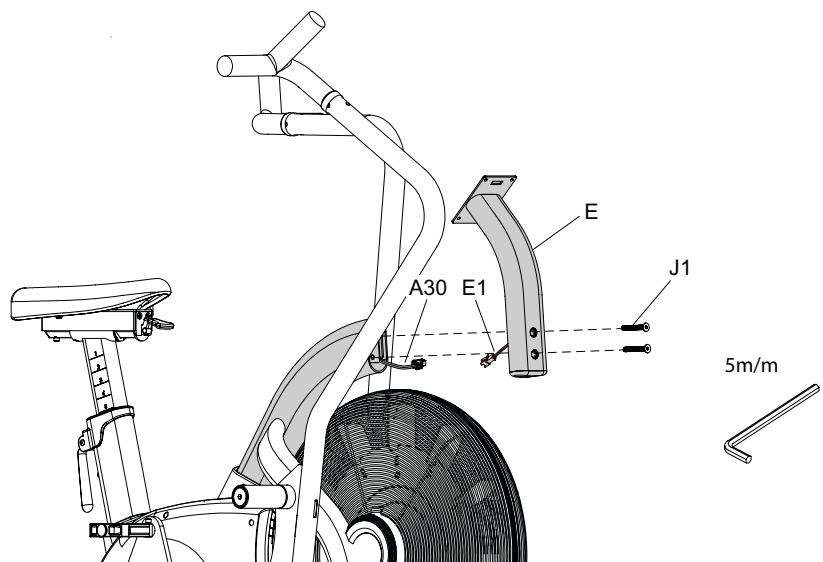

Step 7: Assembly of the console

1. Remove the pre-mounted screws from the console case (F).
2. Connect the cable (E1) with the cable of the console (F).

ⓘ NOTICE

Make sure that there are four AA batteries in the battery compartment. To change the batteries, see chapter 2.4.2.

3. Mount the console with the screw (F1) on the upright post (E).

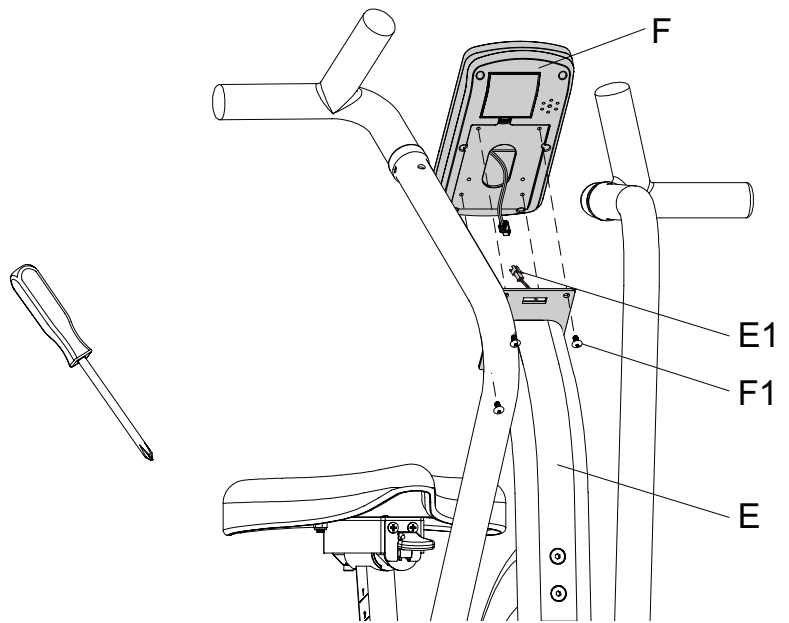

Step 8: Alignment of the feet

If the floor is uneven, you can stabilize the equipment by turning the setting screws under the main frame.

1. Lift the equipment on the desired side and rotate the setting screws under the main frame.
2. Rotate the screws clockwise in order to remove them and to raise the equipment.
3. Rotate them counterclockwise in order to lower the equipment.

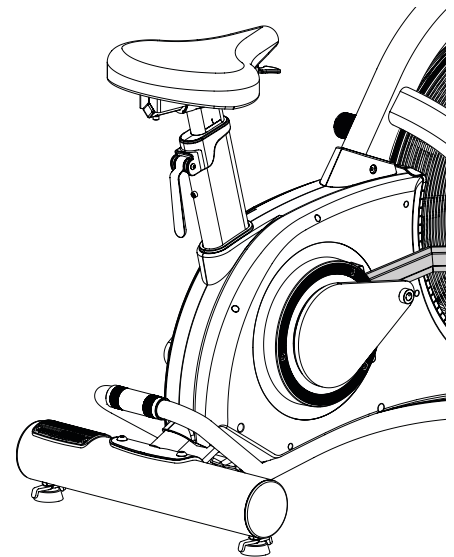

2.4 Further Information

2.4.1 Adjusting the seat post and saddle

Vertikal Adjustment (1)

Pull the adjusting lever (A32) of the seat post up. Once you have found the desired saddle height, push the lever down again to lock the position.

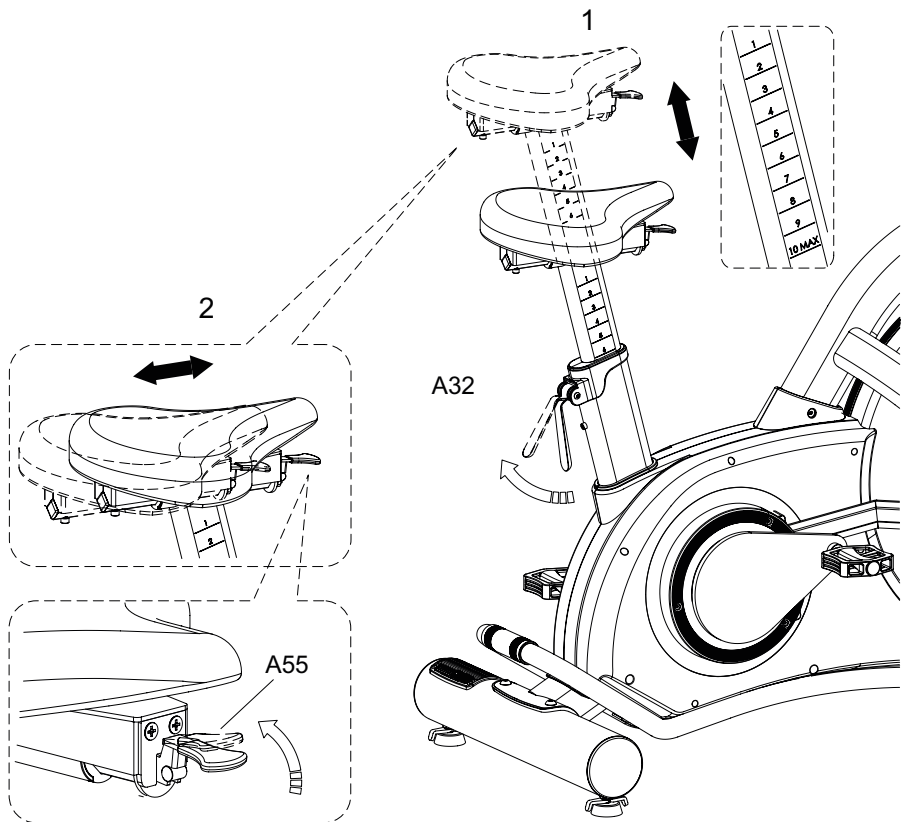

Horizontal Adjustment (2)

Pull the adjusting lever (A55) up to adjust the desired horizontal saddle position. Lock the lever back again, when you have found the desired position.

2.4.2 Changing the batteries

► ATTENTION

- + Make sure the polarity is correct when inserting the batteries.
- + Only use rechargeable AA batteries.

1. Loosen the console screws from the console mast and remove the console.
2. Remove the cover from the battery compartment and insert four new AA batteries.

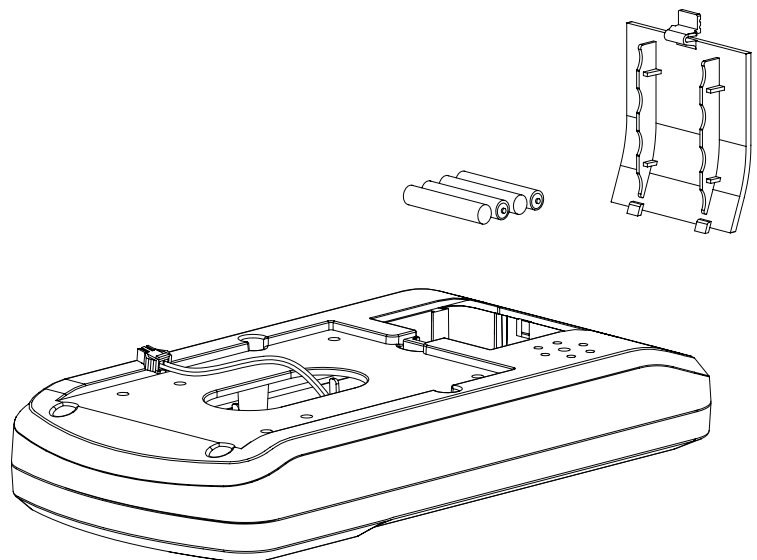

3 OPERATING INSTRUCTIONS

① NOTICE

Familiarise yourself with all the functions and setting options of the device before starting training. Have the proper use of this product explained to you by a specialist.

3.1 Console Display



RPM (UPM)	<ul style="list-style-type: none"> + Displays the rotations per minute + Range: 0 – 15 to 200.
SPEED	<ul style="list-style-type: none"> + Displays the current speed. Maximum speed 99.9 km/h or mph.
TIME	<ul style="list-style-type: none"> + Counts up the time from 00:00 to a maximum of 59:59 or counts down the time from the pre-set time to 00:00. + Target value for time can be set with the UP/DOWN buttons.
DISTANCE	<ul style="list-style-type: none"> + Counts the total distance from 0.0 to 999.9 km or miles or counts the distance of the pre-set target value to 0.0. + The target value for distance can be set with the UP/DOWN buttons.
CALORIES	<ul style="list-style-type: none"> + Counts up the calorie consumption from 0 to a maximum of 999 or down from the pre-set target value to 0. + The target value for calories can be set with the UP/DOWN buttons.
WATT	<ul style="list-style-type: none"> + Displays the energy consumption during the training + Range: 0 to 9999.
PULSE	<ul style="list-style-type: none"> + A target pulse value can be set from 30 to 199. A signal sounds from the console, when the current heart rate is higher or lower than the target value during the training.
INTERVAL	<ul style="list-style-type: none"> + Interval training
TARGET HR	<ul style="list-style-type: none"> + Displays the set target heart rate

3.2 Button Functions

START	Pause or continue the training; hold pressed for two seconds to change between kilometres and miles
STOP	Stop the training; hold pressed for two seconds to reboot the console at any time (TOTAL RESET)
DOWN	Reduce adjustable values (distance, calories, time, age); hold pressed for more than one second to reduce quicker the value; stops when released
UP	Increase adjustable values (distance, calories, time, age); hold pressed for more than one second to increase quickly the value; stops when released
ENTER	Confirm the setting
INTERVAL 20-10	Interval of 20 seconds training and 10 seconds rest; five laps repetition
INTERVAL 10-20	Interval of 10 seconds training and 20 seconds rest; five laps repetition
INTERVAL CUSTOM	User-defined setting of the laps of the interval training and setting of target time
Target Distance	Enter target value for distance
Target Calories	Enter target value for calories
Target HR	Enter target value for heart rate
Target Time	Enter target value for time

3.3 Turning on and off the equipment

When the equipment is turned on (insert batteries), the LCD displays lights up for two seconds (fig. 1), a long signal sounds. Then the wheel diameter is displayed in the DISTANCE window for a second (fig. 2). Then you get to the age setting. The screen displays AGE? (fig. 3). The default value 30 lights up.

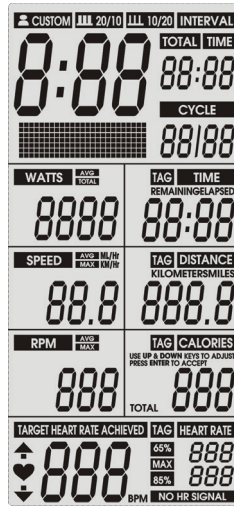

Fig. 1

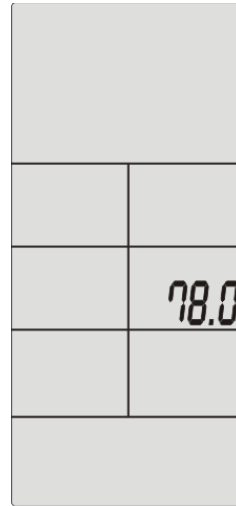
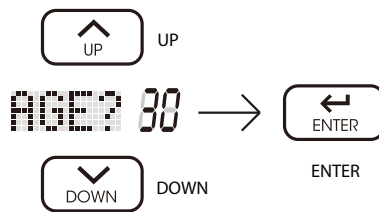

Fig. 2



Fig. 3



Set the age with the UP/DOWN buttons and confirm with ENTER. Then you get to the Standby mode.

The following symbols light up one after the other for a second: Interval, Ready, Work, Rest, Tag Time, Tag Calorie, Tag Distance, Time, Distance, Calories, Watts, Speed, RPM, Heart Rate (fig. 4 to 17).

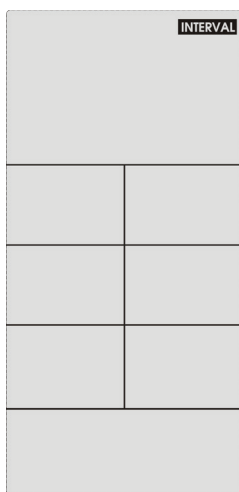

Fig. 4



Fig. 5

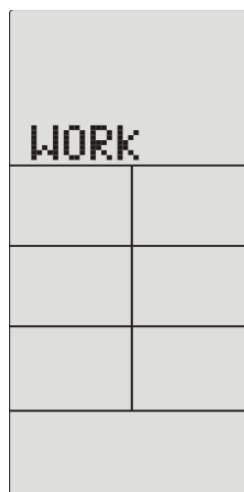

Fig. 6



Fig. 7

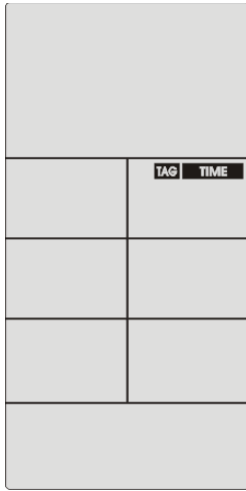

Fig. 8

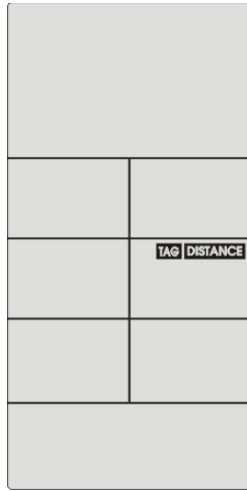

Fig. 9



Fig. 10

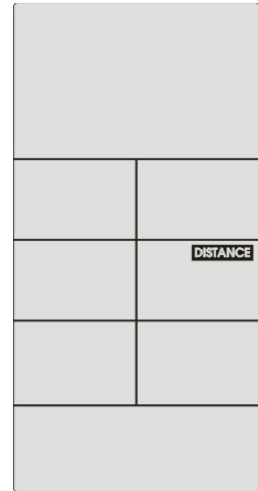

Fig. 11

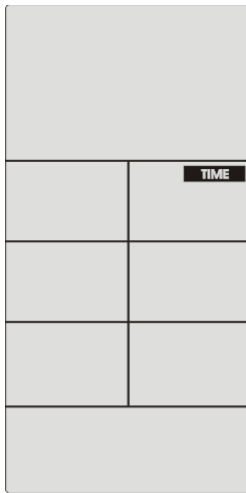

Fig. 12



Fig. 13

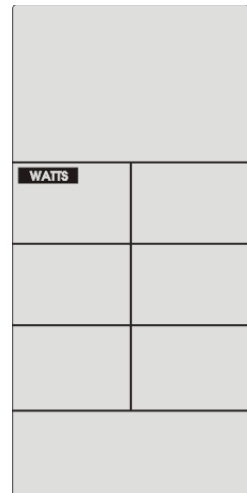

Fig. 14

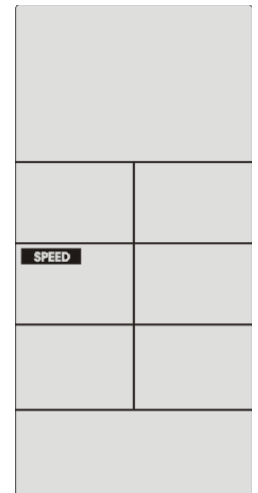

Fig. 15

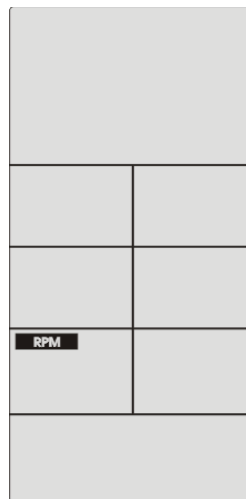

Fig. 16

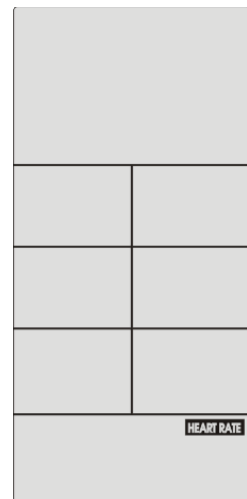

Fig. 17

3.4 Programmes

You can choose from the following programmes:

- + Quick Start
 - + Interval 20-10
 - + Interval 10-20
 - + Interval Custom
 - + Target Time
 - + Target Distance
 - + Target Calories
 - + Target HR
-
- + After a five minutes training break a signal sounds and the console goes to the sleep mode.
 - + Pause the programme for 30 seconds by pressing START. During the pause, a signal sounds regularly. The data are saved and light up every four seconds. Press START to continue the training.
 - + Stop the training with STOP. After the training, your training data of time, distance, and calories are displayed for 30 seconds. The values Watt, speed, and RPM change every five seconds between the display AVG and MAX.
 - + When a pulse signal is detected, the heart rate and the target heart rate are displayed for 30 seconds. 85 %, 65 %, and maximum pulse change in the display every five seconds. When there is no pulse signal, NO HR SIGNAL is permanently displayed.

3.4.1 Quick Start

1. Start the manual mode by starting exercising in the standby mode.

A signal sounds for a second.

The following values are counted: Total Time, Time, Distance, Calories, Watts, Speed, RPM (fig. 18).

① NOTICE

- + Once a pulse signal is detected, a heart flashes. At the same time, HEART RATE, RPM, and the pulse value light up. When there is no pulse signal, NO HR SIGNAL is permanently displayed (fig. 19).
 - + When there is no signal for five seconds, a short signal sounds and the console goes to the sleeping mode.
2. Press START once and the system pauses the training for 30 seconds.

The signal sounds each second for half a second.

All displayed values remain on the LCD screen for three seconds and light up every four seconds.

① NOTICE

- When the equipment is not used for five minutes, a signal sounds for two seconds and the console goes to the sleeping mode.
3. Press START to continue the training.
 4. Press STOP to stop the training.

The signal sounds for a second.

TIME displays the training time, DISTANCE displays the distance, CALORIES displays the energy consumption – all values are displayed for 30 seconds. Watt, speed, and RPM change every five seconds between the displays AVG. & MAX (fig. 20, 21).

NOTICE

When a pulse signal is detected, heart rate, target heart rate, and BPM are displayed for 30 seconds. 85 %, 65 %, and maximum pulse change in the display every five seconds (fig. 20, 21). When there is no pulse signal, NO HR SIGNAL is permanently displayed (fig. 22, 23).

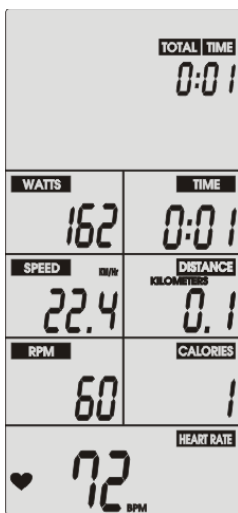
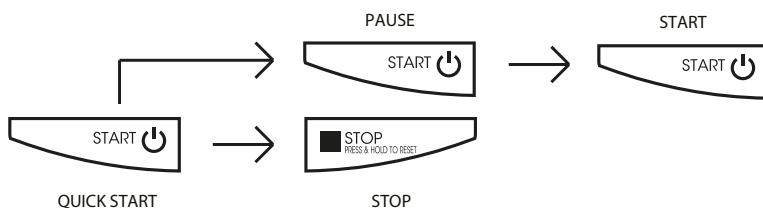

Fig. 18



Fig. 19



Fig. 20



Fig. 21



Fig. 21



Fig. 22

3.4.2 Interval 20-10 Mode

In the standby mode, press INTERVAL 20/10 to start the programme.

- + A countdown of three seconds starts. Then READY flashes and the training begins.
- + A 20-seconds-interval begins. 20 seconds are counted down in the big window. Under the countdown, WORK flashes and signals that you are in the training phase. On the right side, the number of the training interval (CYCLE) is displayed: 01/08 to 08/08. The training data Total Time / Distance / Calories / Watts / Speed / RPM are counted up.
- + A 10-seconds-recovery-interval follows after the 20-seconds-interval. Under the countdown, REST is displayed. All values are still counted.
- + The system repeats the two previous steps. For every step another CYCLE is added until 08/08 is displayed in the CYCLE display (fig. 28). The training is finished with the end of the CYCLE 08/08.

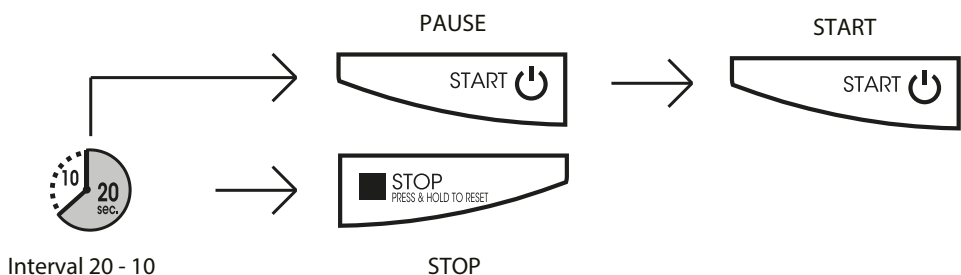

Fig. 24



Fig. 25



Fig. 26



Fig. 27



Fig. 28

3.4.3 Interval 10-20 Mode

In the standby mode, press INTERVAL 10/20 to start the programme.

- + A countdown of three seconds starts. Then READY flashes and the training begins.
- + A 10-seconds-interval begins. 10 seconds are counted down in the big window. Under the countdown, WORK flashes and signals that you are in the training phase. On the right side, the number of the training interval (CYCLE) is displayed: 01/08 to 08/08. The training data Total Time / Distance / Calories / Watts / Speed / RPM are counted up.
- + A 20-seconds-recovery-interval follows after the 10-seconds-interval. Under the countdown, REST is displayed. All values are still counted.
- + The system repeats the two previous steps. For every step another CYCLE is added until 08/08 is displayed in the CYCLE display (fig. 28). The training is finished with the end of the CYCLE 08/08.

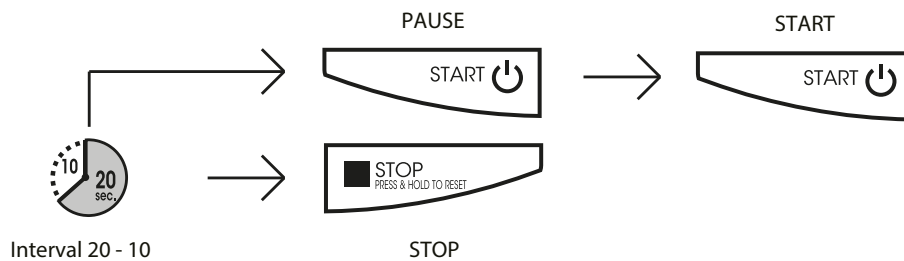

Fig. 29



Fig. 30



Fig. 31



Fig. 32

3.4.4 Interval Custom mode

1. In the standby mode, press INTERVAL CUSTOM to start the programme.
2. Set the desired number (1 to 99) of intervals (CYCLE) with the UP/DOWN buttons and confirm your settings with ENTER.
3. Now you set the duration of the intensive intervals (WORK TIME) with the UP/DOWN buttons and confirm your settings with ENTER.

NOTICE

The interval can last up to 9 minutes and 59 seconds.

4. Now you set the recovery interval (REST TIME) with the UP/DOWN buttons and confirm your settings with ENTER.

NOTICE

The recovery interval can last up to 9 minutes and 59 seconds.

- + A countdown of three seconds starts. Then READY flashes and the training begins.
- + The first interval starts. The remaining time is counted down in the big window. Under the countdown, WORK flashes and signals that you are in the training phase (intensive interval). On the right side, the number of the training interval (CYCLE) is displayed. The training data Total Time / Distance / Calories / Watts / Speed / RPM are counted up.
- + The recovery interval follows after the first workout interval. Under the countdown, RESET is displayed. All values are still counted.
- + The system continues repeating the steps 3 and 4. For every repetition, a CYCLE is added until the desired number of intervals is done. Once the training is finished, a short summary of the session is given on the display.

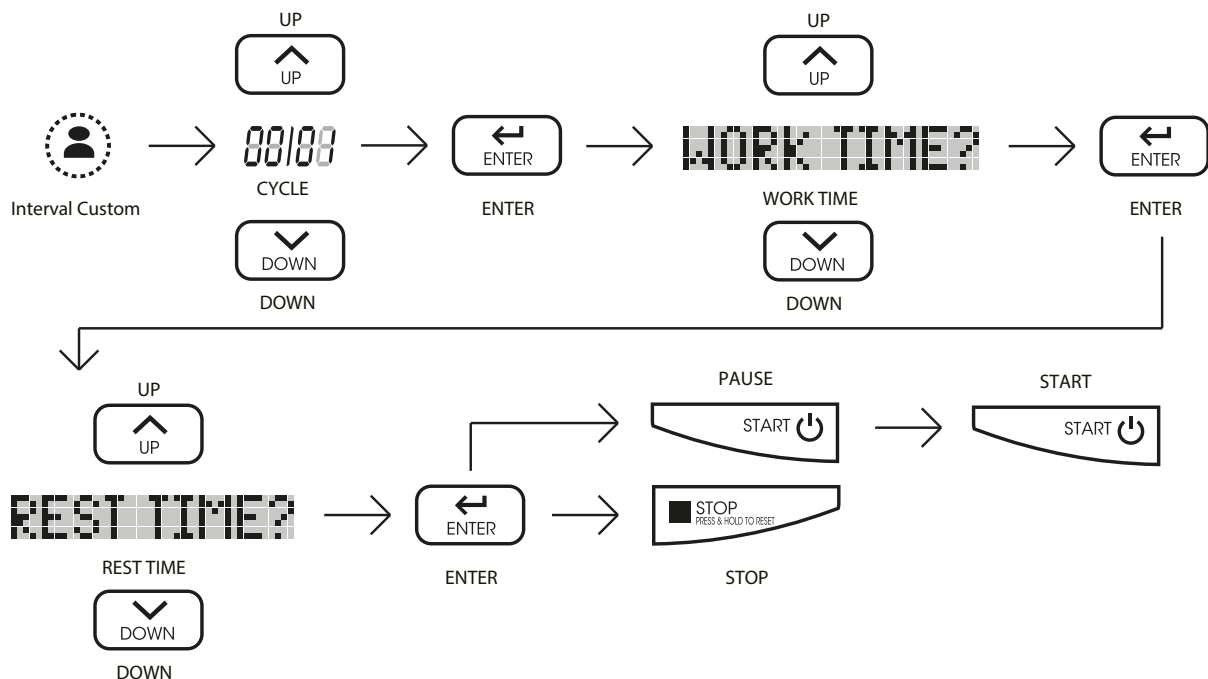



Fig. 33



Fig. 34



Fig. 35



Fig. 36



Fig. 37



Fig. 38



Fig. 39



Fig. 40

3.4.5 Target Time Mode

1. In the standby mode, press TAG TIME to start the programme.
2. Set the target duration with the UP/DOWN buttons and confirm your settings with ENTER.
3. Press START to start the programme.

The training data Total Distance / Calories / Watts / Speed / RPM are counted up.

4. Press START to pause the programme for 30 seconds at any time.

The remaining time is counted down and is displayed in alternation with the time elapsed up to now.

5. Press STOP to stop the training.

When the training is finished, a short summary of the session is displayed.

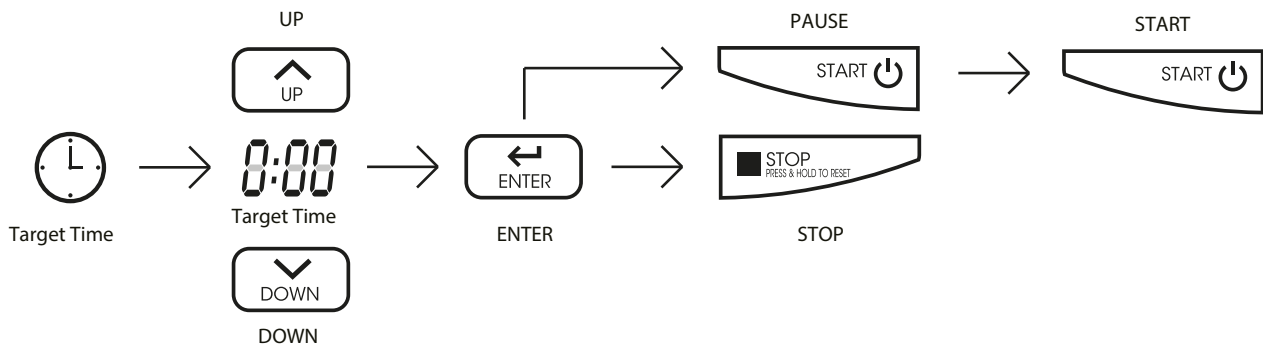

Fig. 41



Fig. 42



Fig. 43

3.4.6 Target Distance Mode

1. In the standby mode, press TAG DISTANCE to start the programme.
2. Set the target distance with the UP/DOWN buttons and confirm your settings with ENTER.
3. Press START to start the programme.

The training data Total Time / Calories / Watts / Speed / RPM are counted up.

4. Press START to pause the programme for 30 seconds at any time.

The target distance is counted down is displayed in alternation with the distance covered up to now.

5. Press STOP to stop the training.

When the training is finished, a short summary of the session is displayed.

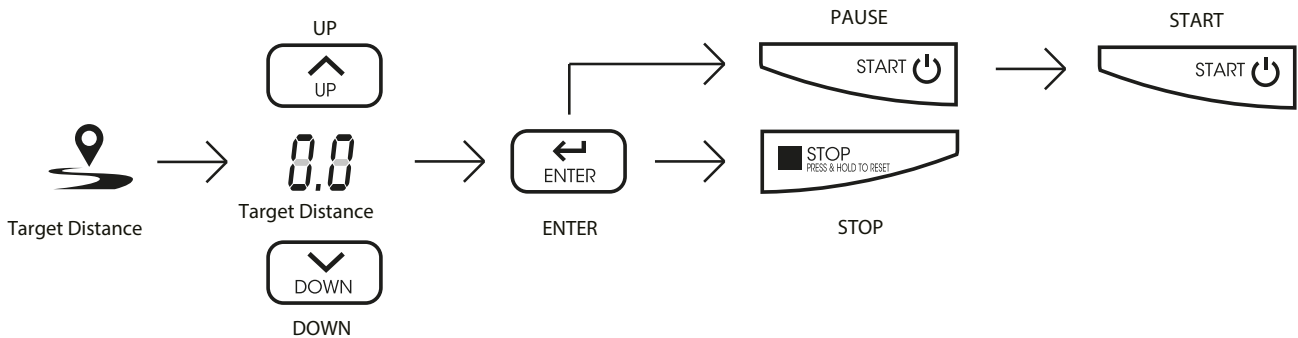

Fig. 44

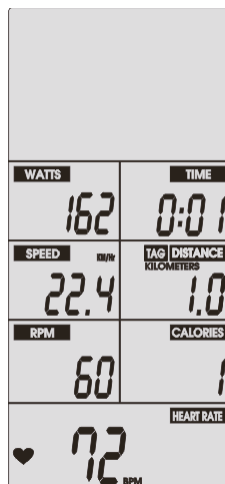

Fig. 45



Fig. 46

3.4.7 Target Calories Mode

1. In the standby mode, press TAG CALORIES to choose the programme.
2. Set the calorie target with the UP/DOWN buttons and confirm your settings with ENTER.
3. Press START to start the programme.

The training data Total Time / Distance / Watts / Speed / RPM are counted up.

4. Press START to pause the programme for 30 seconds at any time.

The calorie target is counted down is displayed in alternation with the calories burnt up to now.

5. Press STOP to stop the training.

When the training is finished, a short summary of the session is displayed.

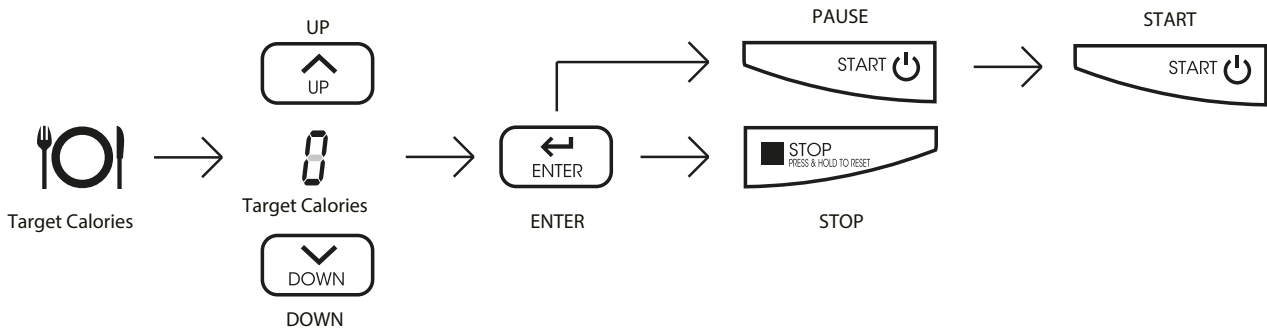

Fig. 47



Fig. 48



Fig. 49

3.4.8 Target HR Mode

⚠ WARNING

Your training equipment is not a medical device. The heart rate measurement of this equipment may be inaccurate. Various factors can affect the accuracy of the heart rate measurement. The heart rate measurement serves only as a training aid.

1. In the standby mode, press TAG HEART RATE to choose the programme.
2. Set your age with the UP/DOWN buttons and confirm your settings with ENTER.

📘 NOTICE

The target heart rate zone is between 65% and 85% of your maximum heart rate and is calculated on the basis of your age.

3. Press START to start the programme.

The training data Total Time / Distance / Calories / Watts / Speed / RPM are counted up.

4. Press START to pause the programme for 30 seconds at any time.

📘 NOTICE

TARGET HEART RATE ACHIEVED is displayed as long as your heart rate is within the target zone between 65 and 85 % of your maximum heart rate. When the heart rate is not in the target zone, it is indicated by an acoustic signal and an arrow upwards (heart rate is too low) or an arrow downwards (heart rate is too high) in the display beside the heart rate. Once you are back again in the target zone, TARGET HEART RATE ACHIEVED is flashed.

5. Press STOP to stop the training.

When the training is finished, a short summary of the session is displayed.

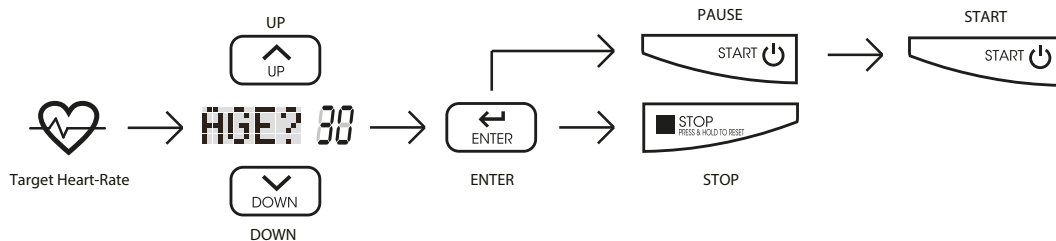

Fig. 50



Fig. 51



Fig. 52



Fig. 53



Fig. 54

4.1 General Instructions

⚠ WARNING

- + The storage location should be chosen so that improper use by third parties or children can be prevented.
- + If your equipment does not have transportation wheels, the equipment must be disassembled before transportation.

▶ ATTENTION

- + Make sure that the equipment is protected from moisture, dust and dirt in the selected storage location. The storage location should be dry and well ventilated and have a constant ambient temperature between 5°C and 45°C.

4.2 Transportation Wheels

▶ ATTENTION

If you want to transport your equipment over particularly sensitive and soft floor coverings, such as parquet, planks or laminate, lay out the transport route with cardboard or similar to avoid possible floor damage.

1. Stand behind the equipment and lift it until the weight is transferred to the transportation wheels. After that, you easily can move the equipment to a new position. For long transport distances the equipment should be disassembled and safely packed.
2. Select the new location by following the instructions in the section 1.3 of this manual.

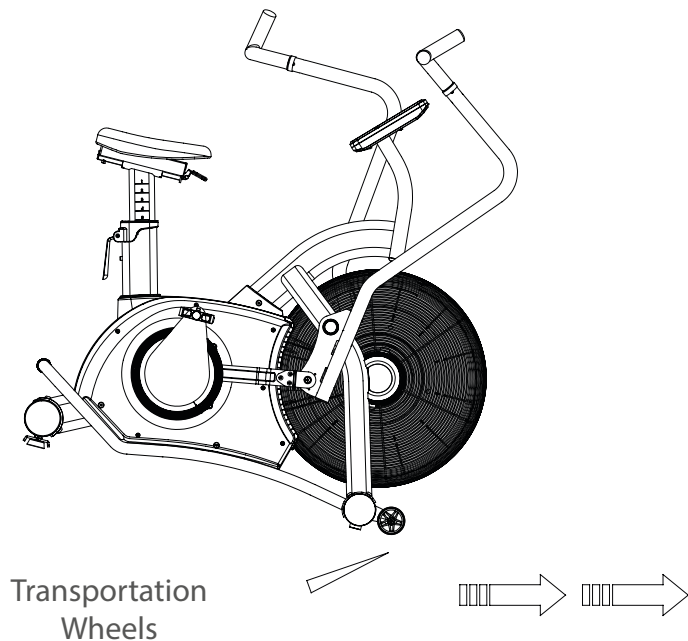
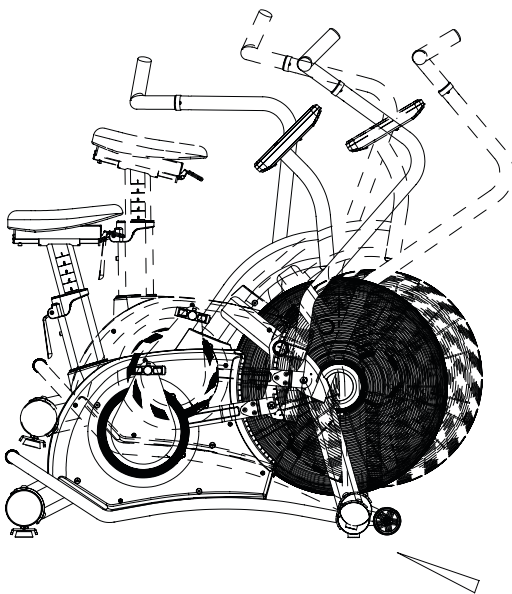

5.1 General Instructions



WARNING

- + Do not make any improper changes to the equipment.



CAUTION

- + Damaged or worn components may affect your safety and the life of the equipment. Therefore, immediately replace damaged or worn components. In such a case, contact the contract partner. The equipment must not be used until it has been repaired. If necessary, use only original spare parts.

► ATTENTION

- + In addition to the instructions and recommendations for maintenance and care given here, additional service and/or repair work may be necessary; this must only be carried out by authorised service technicians.

5.2 Faults and Fault Diagnosis

The equipment undergoes regular quality controls during production. Nevertheless, faults or malfunctions may occur. Frequently, individual parts are responsible for these disturbances, an exchange is usually sufficient. Please refer to the following overview for the most common errors and how to correct them. If the equipment still does not function properly, contact your contract partner.

Fault	Cause	Solution
Cracking in the pedal area	Pedals loose	Tighten the pedals
Equipment wobbles	Equipment is not level	Align the feet
Handlebar/saddle wobbles	Loose screws	Tighten screws firmly
Display is blank/is not working	Batteries empty or loose cable connection	Replace batteries or check cable connections
No pulse display	<ul style="list-style-type: none"> + Sources of interference in the room + unsuitable chest strap + Wrong position of chest strap + Chest strap defective or battery empty + Pulse display defective 	<ul style="list-style-type: none"> + Eliminate sources of interference (e.g. mobile phone, WLAN, lawn mower and vacuum cleaner robot, etc. ...) + Use a suitable chest strap (see RECOMMENDED ACCESSORIES) + Reposition chest strap and/or moisten electrodes + Changing batteries

5.3 Maintenance and Inspection Calendar

To avoid damage from body sweat, the equipment must be cleaned with a damp towel (no solvents!) after each training session.

The following routine tasks must be performed at the specified intervals:

Part	Weekly	Monthly
Display console	C	I
Plastic covers	C	I
Screws and cable connections		I
Legend: C = clean; I = inspect		

6 DISPOSAL

At the end of its operational life, this equipment cannot be disposed of in normal household waste. Instead, it must be disposed of via an electricals recycling centre. Further information can be obtained from your local authority's recycling service.



The materials can be recycled as per their symbols. Through the reuse, recycling of materials or other forms of recovery of old equipment, you make an important contribution to the protection of the environment.

7 RECOMMENDED ACCESSORIES

To make your training experience even more efficient and pleasant, we recommend that you add suiting accessories to your fitness equipment. This could be a floor mat, for example, which makes your fitness equipment stand more securely and also protects the floor from falling sweat, but it could also be additional handrails on some treadmills or silicone spray to keep moving parts in good shape.

If you have purchased a fitness machine with pulse training and want to train your heart rate, we strongly recommend that you use a compatible chest strap, as this ensures optimum transmission of the heart rate. You may want to buy additional grips or weights for multi gyms.

Our range of accessories offers the highest quality and makes training even better. If you would like to find out more about compatible accessories, please go to the detail page of the product in our webshop (the easiest way is to enter the article number in the search field above) and go to the recommended accessories on this page. Alternatively, you can use the QR code provided. Of course, you can also contact our customer service: by telephone, e-mail, in one of our branches or via our social media channels. We will be happy to advise you!



floor mat



chest strap



chest strap contact gel



towels



silicone spray

8.1 Serial Number and Model Name

In order to provide you with the best possible service, please have the model name, article number, serial number, exploded drawing and parts list ready. The corresponding contact options can be found in chapter 10 of this operating manual.

NOTICE

The serial number of your equipment is unique. It's located on a white sticker. The exact position of this sticker is shown in the following illustration.



Enter the serial number in the appropriate field.

Serial number:

Brand / Category:

Model Name:

Article Number:

8.2 Parts List

No.	Name	Supplier Parts No.		Specification	Qty.
A	Main Frame	1	A34	Washer	2
A1	Belt Wheel Φ 360mm	1	A35	Outer Ring(R+L)	2
A2	Belt 690 J6	1	A36	Small Outer Ring(R+L)	2
A3	Magnetic (Φ 15*7Mm)	1	A37	Axle M25*P1.5	1
A4	Screw M8*35	1	A38	Crank(R)	1
A5	Steel Fan Piece	1	A39	Crank(L)	1
A6	Plastic Strip	1	A40	Washer(Φ 25*31*T2mm)	2
A7	Shaped Crank-L	1	A41	Screw M8*40Mm	4
A8	Shaped Crank-R	1	A42	Bearing 6005Zz	2
A10	Washer M5* Φ 13*1T	4	A43	Adapter Sleeve	1
A11	Screw M5*15Mm	4	A44	Screw	1
A12	Nut M12	4	A45	C Clip S25	1
A13	Adjusting Screw M8	2	A46	Saddle(Ls-A22)	1
A14	Fixing Holder	2	A47	Saddle Base	1
A15	Nut M8	2	A48	Spring Washer M8	3
A16	C Clip S52	4	A49	Nut M8	3
A17	Connecting Tube	2	A50	Saddle Post	1
A18	Bearing 2205Zz	2	A51	Screw M6*16Mm	1
A19	Bearing 6301Zz	1	A52	Screw	6
A20	Spacer Ring Φ 19* Φ 12.5* Φ 18.7mm	1	A53	Sliding Sleeve	1
A22	Pulley(Φ 45*80Mm)	1	A54	Square End Cap	1
A23	Screw M6*12Mm	6	A55	Adjustment Bar	1
A24	Sleeve (Φ 19* Φ 12.05*50.3)	1	A56	Quick-Released Axis	1
A25	Bearing 6001	2	A57	Screw M6*15	2
A26	Spacer Ring	1	A58	Threaded Rod	1
A27	Axle(Φ 12*155)	1	A59	Spring	1
A28	Plastic Pipe	1	A60	Ball ϕ 10mm	1
A29	Plastic Pipe	1	A61	Spacer Block	1
A30	Sensor Wire 750Mm	1	A62	Spring	1
A31	Bush(Φ 10*43.2Mm)	1	A63	Bush(Φ 8* Φ 12*7Mm)	1
A32	Fix Grip	1	A64	Nut M6	1
A33	Holder	1	A65	Screw M6*35Mm	1

A66	Steel-Fan Cover-L	1	C5	Screw	4
A67	Steel-Fan Cover-R	1	D1	Swing Handlebar (L)	1
A68	Decoration Cover-L	1	D2	Swing Handlebar (R)	1
A69	Decoration Cover-R	1	D5	Bearing 6202Zz	2
A70	Chain Cover(L)	1	D6	Screw M5*8Mm	4
A71	Chain Cover(R)	1	D7	C Clip S40	2
A72	Sensor Housing	1	D8	Bearing 6203Zz	2
A73	Screw	6	D9	End Cap	2
A74	Screw	6	D10	Bearing 6003 Zz	2
A75	Screw M6*20Mm	1	D11	Spring Washer Φ 17	2
A76	Steel	4	E	Console Tube	1
A77	Pad	1	E1	Sensor Wire 450Mm	1
A78	Brake Pad	2	E2	End Cap	1
A79	Spring	1	F	Console	1
A80	Screw M6*10Mm	2	F1	Screw	4
A81	Sensor Wire 150Mm	1	G1	Foot Support	2
A82	Plastic Cover	1	G2	End Cap	2
B	Front Stabilizer	1	H1	Pedal-L	1
B1	End Cap	2	H2	Pedal-R	2
B2	Wheel	2	I	Metal Fixing Plate	1
B3	Screw M8*40	2	J1	Screw M8*60Mm	1
B4	Nut M8	2	J2	Screw M8*30Mm	
B5	Adjusting End Cap	2	J3	Spacer Ring	2
B6	Screw	4	J4	Nut M8	2
C	Rear Stabilizer	1	J5	Screw M6*12Mm	6
C1	End Cap Φ 101.6	2	J6	Screw M10*20Mm	8
C2	Nut	2	J7	Screw M6*8Mm	2
C3	Knob Φ 50	2	J8	Spacer Ring	2
C4	Step Mat	1			

8.3 Exploded Drawing

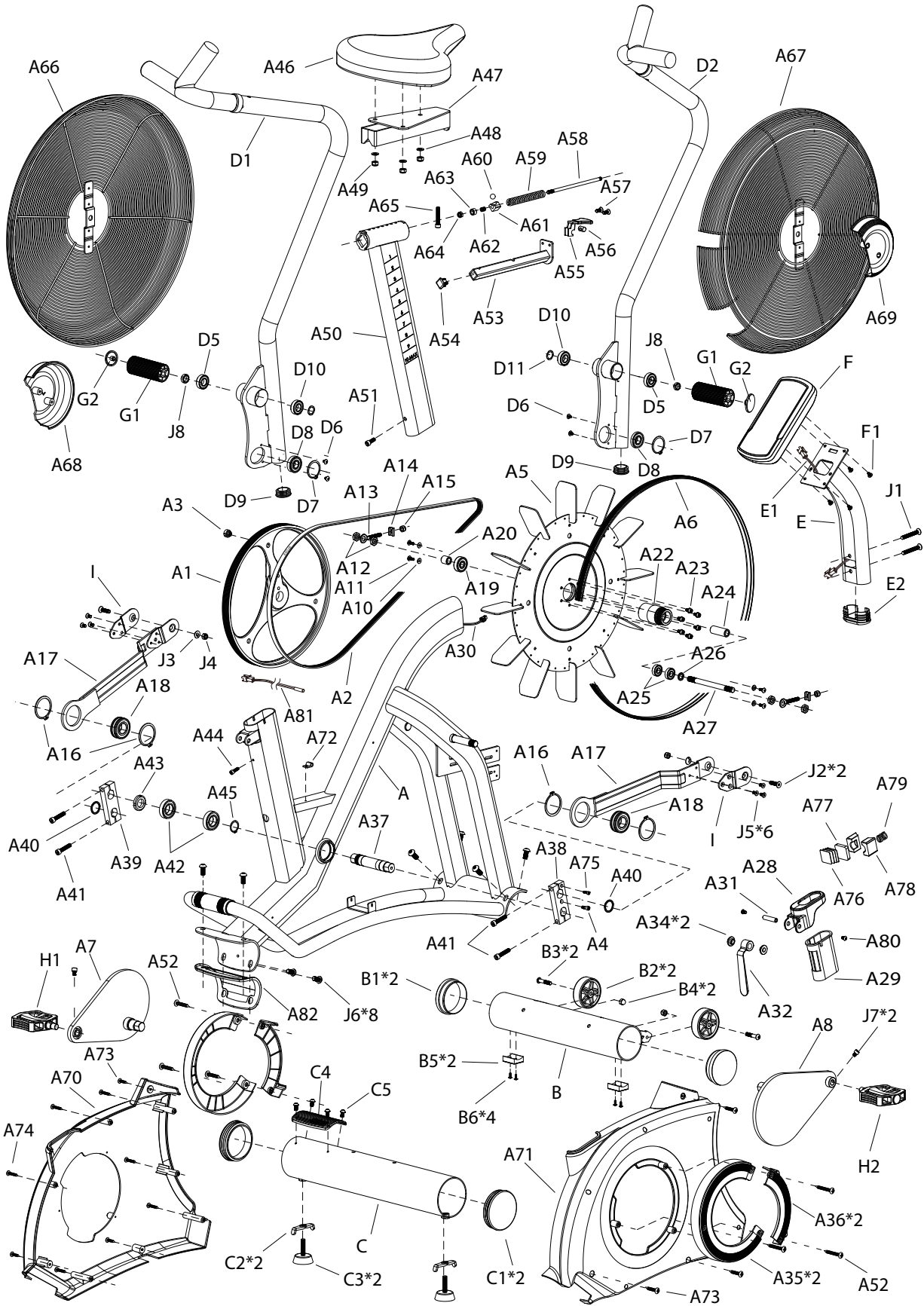

Training equipment from Taurus® is subject to strict quality control. However, if a fitness equipment purchased from us does not work perfectly, we take it very seriously and ask you to contact our customer service as indicated. We are happy to help you by phone via our service hotline.

Error Descriptions

Your fitness equipment is developed for long-term, high-quality training. However, should a problem arise, please first read the operating instructions. For further assistance, please contact your contract partner or call our service hotline. To ensure your problem is solved as quickly as possible, please describe the defect as exactly as possible.

In addition to the statutory warranty, we provide a warranty for every fitness equipment purchased from us according to the following provisions.

Your statutory rights are not affected.

Warrantee

The warrantee is the first/original buyer and/or any person who received a newly purchased product as a gift from the original buyer.

Warranty period

The warranty periods, shown on our web shop, begin on delivery of the fitness equipment. The respective warranty periods for your equipment can be found on its product website.

Repair Costs

According to our choice, there will either be a repair, a replacement of individual damaged parts or a complete replacement. Spare parts, that have to be mounted while assembling the equipment, have to be replaced by the warrantee personally and are not a part of repair. After the expiration of the warranty period for repair costs, a pure parts warranty applies, which does not include the repair, installation and delivery costs.

The terms of use are defined as follows:

- + Home use: solely for private use in private households up to 3 hours per day
- + Semi-professional use: up to 6 hours per day (e. g. rehabilitation centres, hotels, clubs, company gyms)
- + Professional use: more than 6 hours per day (e. g. commercial gyms)

Warranty Service

Within the warranty period, equipment which develops faults as a result of material or manufacturing defects, will be repaired or replaced at our discretion. Ownership of equipment or parts of equipment which have been replaced is transferred to us. The warranty period is not extended nor does a new warranty period begin following repair or replacement under the warranty.

Warranty Conditions

For the warranty to be valid, the following steps must be taken:

Please contact our customer service by email or phone. If the product under warranty has to be sent in for repair, the seller bears costs. After expiry of the warranty, the buyer bears the costs of transport and insurance. If the fault is covered by our warranty, you will receive a new or repaired equipment in return.

Warranty claims are invalid in case of damage resulting from:

- + misuse or improper handling
- + environmental influences (moisture, heat, electrical surge, dust, etc.)
- + failure to follow the current safety measures for the equipment
- + failure to follow the operating instructions
- + use of force (e. g. hitting, kicking, falling)
- + interventions which were not carried out by one of our authorized service centres
- + unauthorised repair attempts

Proof of Purchase and Serial Number

Please make sure that you are able to provide the appropriate receipt when claiming on your warranty. So that we can clearly identify the model of your equipment, and for the purposes of our quality control, you will need to give the serial number of your equipment, when contacting the service team. Where possible please have your serial number and your customer number ready when you call our service hotline. It will help us to deal with your request swiftly.

If you cannot find the serial number on your fitness equipment, our service team is at your disposal to offer further information.

Service outside of the Warranty Period

We are also happy to issue an individual cost estimate if there is a problem with your fitness equipment after the warranty has expired, or in cases which do not fall under the terms of the warranty, e. g. normal wear and tear. Please contact our customer service team to find a quick and cost-effective solution to your problem. In such a case you will be responsible for the delivery costs.

Communication

Many problems can be solved just by speaking to us as your specialist supplier. We know how important it is to you as a user of the fitness equipment to have problems solved quickly and simply, so you can enjoy working out with minimal interruption. For that reason, we also want to resolve your queries quickly and in a straightforward manner. Thus, please always keep your customer number and the serial number of the faulty equipment handy.

DE	DK	FR
<p>TECHNICAL SUPPORT</p> <p>☎ +49 4621 4210-900 ☎ +49 4621 4210-698 ✉ technik@sport-tiedje.de 🕒 Mo - Fr 08:00 - 18:00 Sa 09:00 - 18:00</p> <p>SERVICE</p> <p>☎ 0800 20 20277 (Freecall) ✉ info@sport-tiedje.de 🕒 Mo - Fr 08:00 - 21:00 Sa 09:00 - 21:00 So 10:00 - 18:00</p>	<p>TECHNICAL SUPPORT & SERVICE</p> <p>☎ 80 90 16 50 +49 4621 4210-945 ✉ info@fitshop.dk 🕒 Mo - Fr 08:00 - 18:00 Sa 09:00 - 18:00</p>	<p>TECHNICAL SUPPORT & SERVICE</p> <p>☎ +33 (0) 172 770033 +49 4621 4210-933 ✉ service-france@fitshop.fr 🕒 Mo - Fr 08:00 - 18:00 Sa 09:00 - 18:00</p>
	PL	BE
	<p>TECHNICAL SUPPORT & SERVICE</p> <p>☎ 22 307 43 21 +49 4621 42 10-948 ✉ info@fitshop.pl 🕒 Mo - Fr 08:00 - 18:00 Sa 09:00 - 18:00</p>	<p>TECHNICAL SUPPORT & SERVICE</p> <p>☎ 02 732 46 77 +49 4621 42 10-932 ✉ info@fitshop.be 🕒 Mo - Fr 08:00 - 18:00 Sa 09:00 - 18:00</p>

UK	NL	INT
<p>TECHNICAL SUPPORT</p> <p>☎ +44 141 876 3986 ✉ support@powerhousefitness.co.uk</p> <p>SERVICE</p> <p>☎ +44 141 876 3972 🕒 Mo - Fr 9am - 5pm</p>	<p>TECHNICAL SUPPORT & SERVICE</p> <p>☎ +31 172 619961 ✉ info@fitshop.nl 🕒 Ma - Do 09:00 - 17:00 Vr 09:00 - 21:00 Za 10:00 - 17:00</p>	<p>TECHNICAL SUPPORT & SERVICE</p> <p>☎ +49 4621 4210-944 ✉ service-int@sport-tiedje.de 🕒 Mo - Fr 8am - 6pm Sat 9am - 6pm</p>
	AT	CH
	<p>TECHNICAL SUPPORT & SERVICE</p> <p>☎ 0800 20 20277 (Freecall) +49 4621 42 10-0 ✉ info@sport-tiedje.at 🕒 Mo - Fr 08:00 - 18:00 Sa 09:00 - 18:00</p>	<p>TECHNICAL SUPPORT & SERVICE</p> <p>☎ 0800 202 027 +49 4621 42 10-0 ✉ info@sport-tiedje.ch 🕒 Mo - Fr 08:00 - 18:00 Sa 09:00 - 18:00</p>

Please find a detailed overview including address and opening hours for all stores of the Sport-Tiedje Group in Germany and abroad on the following website:

www.sport-tiedje.com/en/stores

WE LIVE FITNESS

WEBSHOP AND SOCIAL MEDIA

Sport-Tiedje is Europe's largest specialist store for home fitness equipment with currently 80 stores and one of the world's most renowned online mail order companies for fitness equipment. Private customers order via the 25 web shops in the respective national language or have their desired equipment assembled on site. In addition, the company supplies fitness studios, hotels, sports clubs, companies and physio practices with professional equipment for endurance and strength training.

Sport-Tiedje offers a wide range of fitness equipment from renowned manufacturers, high-quality in-house developments and comprehensive services, such as a build-up service and sports scientific advice before and after the purchase. The company employs numerous sports scientists, fitness trainers and competitive athletes.

Visit us also on our social media platforms or our blog!

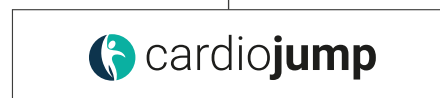
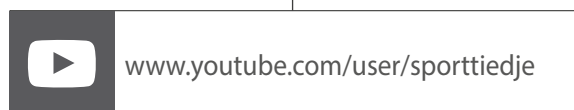
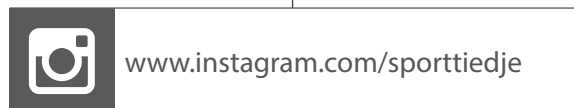
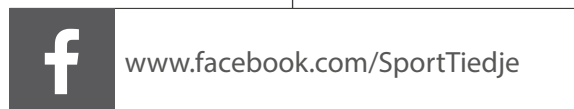

TAURUS®