

# TAURUS®

## Assembly and Operating Instructions



max. 180 kg



~ 90 Min.



127 kg

L 211 | W 82 | H 188

FSTFFX99.01.02

Art. No TF-FX99

**Elliptical Trainer FX9.9**



# Content

<b>1</b>	<b>GENERAL INFORMATION</b>	<b>8</b>
1.1	Technical Data	8
1.2	Personal Safety	9
1.3	Electrical Safety	10
1.4	Set-Up Place	11
<b>2</b>	<b>ASSEMBLY</b>	<b>12</b>
2.1	General Instructions	12
2.2	Scope of Delivery	13
2.3	Assembly	14
<b>3</b>	<b>OPERATING INSTRUCTIONS</b>	<b>23</b>
3.1	Console display	23
3.2	Button functions	24
3.3	Powering on the crosstrainer	25
3.4	Standby mode	25
3.5	MANUAL (Manual programs)	26
3.5.1	Quick-Start program	26
3.5.2	Target programs	26
3.6	PROGRAM (Profile programs)	27
3.7	USER (User defined program)	29
3.8	H.R.C. (Heart rate controlled programs)	30
3.9	WATT (Watt program)	31
3.10	RECOVERY (Recovery function)	31
3.11	BODY FAT (Body fat analysis)	32
3.12	Wireless Connection and Fitness Apps	33
<b>4</b>	<b>STORAGE AND TRANSPORT</b>	<b>34</b>
4.1	General Instructions	34
4.2	Transportation Wheels	34
<b>5</b>	<b>TROUBLESHOOTING, CARE AND MAINTENANCE</b>	<b>35</b>
5.1	General Instructions	35
5.2	Faults and Fault Diagnosis	35
5.3	Error codes and troubleshooting	36
5.4	Maintenance and inspection calendar	37
<b>6</b>	<b>DISPOSAL</b>	<b>37</b>

<b>7</b>	<b>RECOMMENDED ACCESSORIES</b>	<b>38</b>
<b>8</b>	<b>ORDERING SPARE PARTS</b>	<b>39</b>
8.1	Serial Number and Model Name	39
8.2	Parts List	40
8.3	Exploded Drawing	45
<b>9</b>	<b>WARRANTY</b>	<b>46</b>
<b>10</b>	<b>CONTACT</b>	<b>48</b>

**Dear customer,**

Thank you for choosing a high-quality equipment of the brand TAURUS®. Taurus offers sports and fitness equipment for the sophisticated home sport and the equipment of fitness studios and business customers. With Taurus fitness equipment, the focus is on what sport is all about: maximum performance! Therefore, the equipment is developed in close consultation with athletes and sports scientists. Because athletes know best what makes perfect fitness equipment.

Further information can be found at [www.fitshop.com](http://www.fitshop.com).

**Intended Use**

The equipment may only be used for its intended purpose.

The equipment is suitable for home use and semi-professional use (e.g. hospitals, clubs, hotels, schools, etc.). The equipment is not suitable for commercial or professional use (e.g. fitness studio).

**Legal Notice**

Fitshop GmbH  
Europe's No. 1 for home fitness

International Headquarters  
Flensburger Straße 55  
24837 Schleswig  
Germany

Management:  
Christian Grau  
Sebastian Campmann  
Dr. Bernhard Schenkel  
No. HRB 1000 SL  
Local Court Flensburg  
European VAT Number: DE813211547

**Disclaimer**

© TAURUS is a registered brand of the company Fitshop GmbH. All rights reserved. Any use of this trademark without the explicit written permission of Fitshop is prohibited.

Product and manual are subject to change. Technical data can be changed without advance notice.

**FITSHOP**

Europe's No.1 for Home Fitness

## ABOUT THIS MANUAL

Please carefully read the entire manual before installation and first use. The manual will help you to quickly set up the system and explains how to safely use it. Make sure that all persons exercising with the equipment (especially children and persons with physical, sensory, mental or motor disabilities) are informed about this manual and its contents in advance. In case of doubt, responsible persons must supervise the use of the equipment.



Due to ongoing changes and software optimisations, the manual may have to be updated. If you notice any discrepancies during assembly or use, please refer to the manual uploaded to the webshop. The latest manual is always available there.

This equipment has been manufactured according to the latest safety knowledge. As far as possible, potential safety hazards which could cause injury have been eliminated. Make sure to carefully follow the instructions and that all parts are securely in place. If required, read through the instructions again to correct any mistakes.

Training devices must be classified according to accuracy and use. Accuracy classes are only applicable to devices that display training data.

### Accuracy classes

Class A: high accuracy.

Class B: medium accuracy.

Class C: low accuracy.

The use classes explain the intended use of the training device.

### Use classes

**Class S** (studio): professional and/or commercial use.

These training devices are intended for the use in training rooms of facilities such as sports clubs, school facilities, hotels, clubs and studios whose access and supervision is specifically regulated by the owner (person with legal responsibility).

**Class H** (home use): use at home.

These stationary training devices are intended for the use in private homes where access to the training device is regulated by the owner (person with legal responsibility).

Please pay close attention to the safety and maintenance instructions given here. The contract partner cannot be held liable for damage to health, accidents or damage to the equipment when it is not used in accordance with these instructions.

The following safety instructions may appear in this manual:

► **ATTENTION**

This notice indicates potentially hazardous situations which, if not avoided, may result in property damage.

⚠ **CAUTION**

This notice indicates potentially hazardous situations which, if not avoided, may result in slight or minor injuries!

⚠ **WARNING**

This notice indicates potentially hazardous situations which, if not avoided, may result in death or serious injuries!

⚠ **DANGER**

This notice indicates potentially hazardous situations which, if not avoided, will result in death or serious injuries!

ⓘ **NOTICE**

This notice indicates further useful information.

Retain these instructions in a safe place for future reference, maintenance or when ordering replacement parts.

## 1.1 Technical Data

### LCD Display:

- + Training duration in min.
- + Speed in km/h
- + Training distance in km
- + Calories in kcal
- + Resistance level
- + Incline level
- + Heart rate (using the hand pulse sensors or a chest strap)
- + RPM
- + Watts

Brake system: Electro-magnetic induction brake  
Resistance levels: 32

Wattage  
Adjustable range in the watt programme: 10-350 W  
Min. and max. Watt at 60 RPM: 50-400 W  
Min. and max. Watt at 100 RPM: 148-765W

User profiles: 4  
Programs in total: 25  
Quick-start program: 1  
Target programs: 4  
Pre-set programs: 12  
User defined programs: 1  
Heart rate programs: 4  
Watt programs: 1

Stride length: max. 56 cm  
Stride height: 14 cm  
Transfer ratio: 1:8.75  
Flywheel mass: 10 kg

### Weight and dimensions:

Packed dimensions (LxBxH): 130 cm x 66 cm x 98 cm  
Assembled dimensions (LxBxH): 211 cm x 82 cm x 188 cm  
Article weight (gross, incl. packaging): 150.6 kg  
Article weight (net, without packaging): 127 kg

Maximum user weight: 180kg  
Use class: S



## 1.2 Personal Safety

### **DANGER**

- + Before you start using the equipment, you should consult your physician that this type of exercise is suitable for you from a health perspective. Particularly affected are persons who: have a hereditary disposition to high blood pressure or heart disease, are over the age of 45, smoke, have high cholesterol values, are overweight and/or have not exercised regularly in the past year. If you are under medical treatment that affects your heart rate, medical advice is absolutely essential.
- + Note that excessive training can seriously endanger your health. Please also note that heart rate monitoring systems can be inaccurate. If you notice any signs of weakness, nausea, dizziness, pain, shortness of breath, or other abnormal symptoms, stop exercising immediately and seek advice from your doctor if necessary.
- + The owner must communicate all warnings and instructions to the user.

### **WARNING**

- + This equipment may not be used by children under the age of 14.
- + Children should not be allowed unsupervised access to the equipment.
- + Persons with disabilities must have a medical license and must be under strict observation when using the equipment.
- + Remember that your device does not have a freewheel function. Therefore moving parts cannot be stopped immediately.
- + Note that the individual physical power required to perform an exercise may differ from the displayed mechanical power.
- + When ascending and descending, make sure that one of the treads is in the lowest position.
- + The equipment is strictly for use by one person at a time.
- + Keep your hands, feet and other body parts, hair, clothing, jewellery and other objects well clear of moving parts.
- + During use, wear suitable sports clothing rather than loose or baggy clothing. When wearing sports shoes, make sure they have suitable soles, preferably made of rubber or other non-slip materials. Shoes with heels, leather soles, studs or spikes are unsuitable. Never exercise barefoot.

### **CAUTION**

- + If your equipment needs to be connected to the power supply with a mains cable, make sure that the cable is not a potential tripping hazard.
- + Make sure that nobody is within the range of motion of the equipment during training so as not to endanger you or other persons.
- + Do not insert any objects of any kind into the openings of the device.
- + Be aware that if adjustment devices are left protruding, they may impede the user's movement.

## 1.3 Electrical Safety

### **DANGER**

- + In order to reduce the risk of an electric shock, always unplug the equipment from the mains socket immediately after your workout, before assembly or dismantling, and before maintenance or cleaning. Do not pull on the cable.

### **WARNING**

- + Do not leave the equipment unattended while the mains cable is plugged into the mains socket. During your absence, the mains cable must be removed from the mains socket to prevent improper use by third parties or children.
- + If the mains cable or plug is damaged or defective, contact your contract partner. Until repair, the equipment must not be used.

### **ATTENTION**

- + The equipment requires a mains connection of 220-230 V with 50 Hz mains voltage.
- + The equipment may only be connected directly to an earthed socket using the supplied mains cable. Extension cables must conform to VDE guidelines. Always completely unwind the mains cable.
- + The socket must be protected by a fuse with a minimum fuse rating of "16 A, slow blow".
- + Do not make any changes to the mains cable or the mains plug.
- + Keep the mains cable away from water, heat, oil and sharp edges. Do not route the mains cable underneath the equipment or under a carpet or rug, and do not place any objects on top of it.
- + If your purchased item is equipped with a TFT console, software updates must be carried out regularly. Follow the instructions on the console to perform the update(s).
- + The software systems on gym equipment with TFT consoles are set up only for the pre-installed apps. Do not install any additional apps.

### **NOTICE**

- + The pre-installed apps on TFT consoles are produced and provided by external manufacturers. Fitshop does not take any responsibility for the availability, functionality or contents of these apps.

## 1.4 Set-Up Place

### **WARNING**

- + Do not place the equipment in main corridors or escape routes.

### **CAUTION**

- + Choose a location in which to place the equipment such that there is enough free space/clearance to the front, the rear and to the sides of the equipment.
- + The training room should be well ventilated during training and not be exposed to any draughts.
- + Choose the place in which to set up the equipment such that there is enough free space/clearance to the front, the rear and to the sides of the equipment.
- + The free area in the direction from which the exercise equipment is accessed must be at least 0.6 m larger than the exercise area.
- + The set-up and mounting surface of the equipment should be flat, loadable and solid.

### **ATTENTION**

- + The device may only be used in one building, in sufficiently tempered and dry rooms (ambient temperatures between 10°C and 35°C). The equipment should not be used outdoors or in rooms with high humidity (over 70%) like swimming pools.
- + A floor protective mat/equipment underlay can help to protect high-quality floor coverings (parquet, laminate, cork, carpets) from dents and sweat and can help to level out slight unevenness.
- + For Class S equipment, the exercise equipment may only be used in areas where access, supervision and control are specifically regulated by the owner.

### 2.1 General Instructions



#### **DANGER**

- + Do not leave any tools, packaging materials such as foils or small parts lying around, as otherwise there is a danger of suffocation for children. Keep children away from the equipment during assembly.



#### **WARNING**

- + Pay attention to the instructions attached to the equipment in order to reduce the risk of injuries.



#### **CAUTION**

- + Do not open the packaging when it is lying on its side.
- + Ensure to have sufficient room for movement in each direction during assembly.
- + The assembly of the equipment must be carried out by at least two adults. If in doubt, seek the help of a third technically skilled person.



#### **ATTENTION**

- + To prevent damage to the equipment and the floor, assemble the equipment on a mat or packaging board.



#### **NOTICE**







- + In order to make the assembly as simple as possible, some screws and nuts to be used can already be pre-assembled.
- + Ideally, assemble the equipment at its later set-up place.

## 2.2 Scope of Delivery

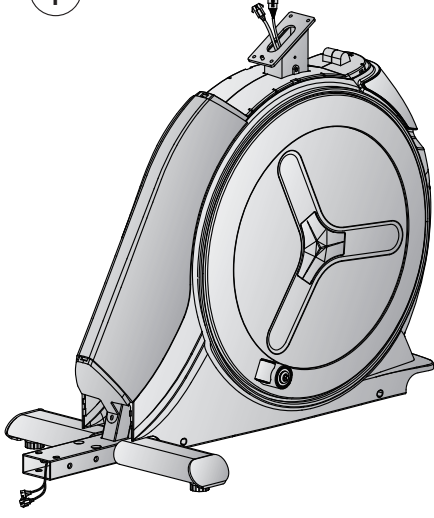
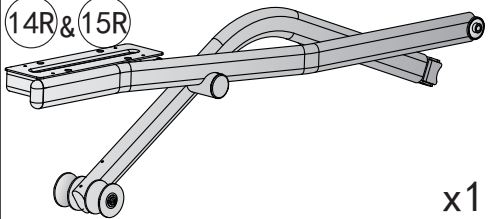
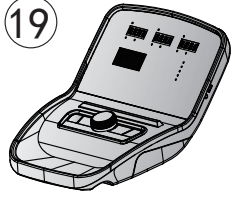
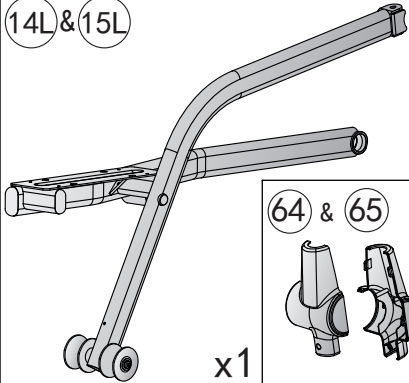
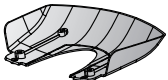
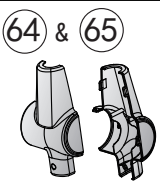
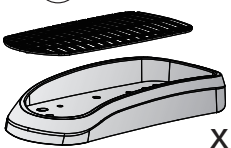
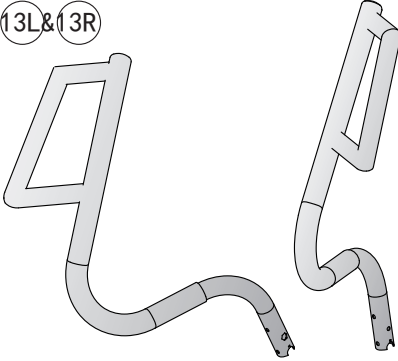
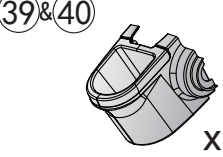
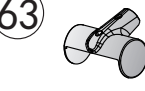
The scope of delivery consist of the following parts. At the beginning, check whether all parts and tools belonging to the device are included in the scope of delivery and whether damage has occurred. In the event of complaints, the contractual partner must be contacted directly.

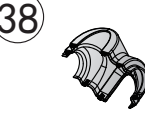
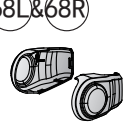
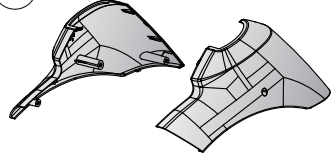
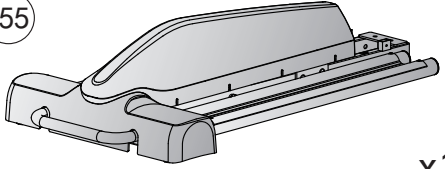
**⚠ CAUTION**

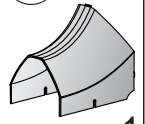
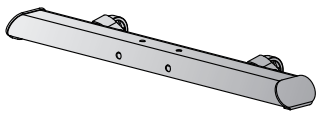
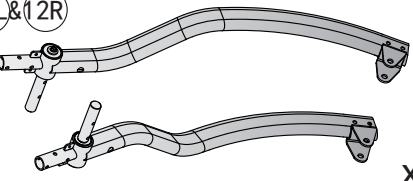
If parts of the scope of delivery are missing or damaged, the assembly must not be carried out.

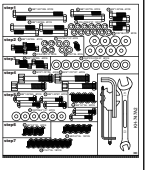
 <p>1</p> <p>x1</p>	 <p>14R &amp; 15R</p> <p>x1</p>	 <p>19</p> <p>x1</p>	
	 <p>14L &amp; 15L</p> <p>x1</p>	 <p>118</p> <p>x1</p>	
	 <p>64 &amp; 65</p> <p>x2</p>	 <p>44 &amp; 45</p> <p>x2</p>	
	 <p>13L &amp; 13R</p> <p>x1</p>	 <p>39 &amp; 40</p> <p>x1</p>	 <p>63</p> <p>x2</p>
	 <p>98 &amp; 99</p> <p>x1</p>	 <p>38</p> <p>x1</p>	 <p>68L &amp; 68R</p> <p>x2</p>
 <p>30L &amp; 30R</p> <p>x1</p>	 <p>155</p> <p>x1</p>	 <p>117</p> <p>x1</p>	 <p>33</p> <p>x1</p>
 <p>2</p> <p>x1</p>	 <p>12L &amp; 12R</p> <p>x1</p>	 <p>71</p> <p>x2</p>	 <p>x1</p>

## 2.3 Assembly

Before assembly, take a close look at the individual assembly steps shown and carry out the assembly in the order given.

### NOTICE

- + First loosely screw all parts together and check that they fit properly. Tighten the screws using the tool only when you are instructed to do so.
- + If you have difficulty recognising the graphics, we recommend that you open and/or download the PDF instructions stored in the webshop on your end device (e.g. smartphone, tablet or PC). There you have the option of zooming in closer. Please note that the Adobe Acrobat Reader programme must be installed on your end device in order to open the file.







### Step 1: Assembling the front and rear feet

1. Screw the frontal foot (2) to the main frame (1) with two hexagonal screws (3), two hexagonal screws (5) and four spring washers (4). Only hand tighten the screws in place.
2. Connect the incline cable (158) and the control cable (167) together.
3. Connect both incline control cables (165 & 166) together.

### ATTENTION

In the following step please pay attention that you don't clamp the cables between the frames.

4. Screw the rear foot with the rails (155) to the main frame (1) with eight washers (51), eight spring washers (4), four hexagonal screws (147), four hexagonal screws (148) and hand tighten the screws in place.

③		M8*1.25*120L	x2
⑤		M8*1.25*70L	x2
①47		M8*1.25*55L	x4
①48		M8*1.25*35L	x4
④		D15.4*D8.2*2T	x12
⑤1		D25*D8.5*2T	x8

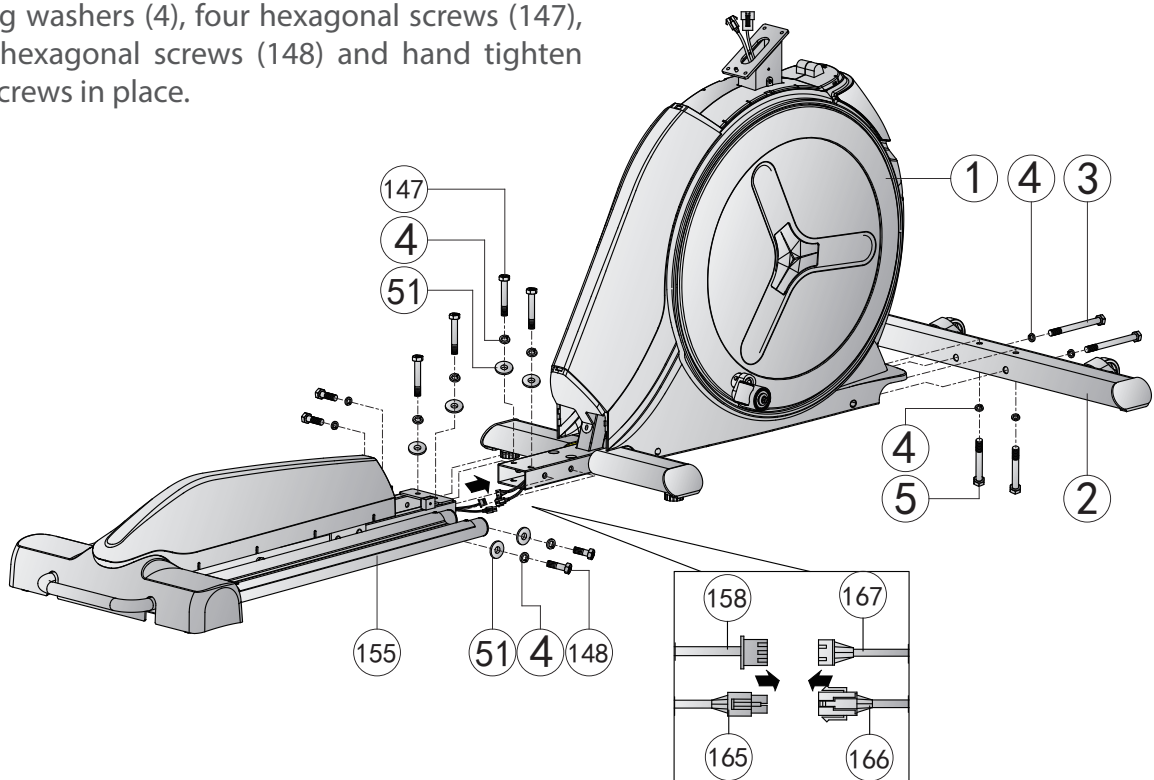





## Step 2: Assembling the console mast

1. Connect the console cable in the mast (101) with the console cable in the main frame (102).
2. Connect the signal cable in the mast (178) with the signal cable in the main frame (179).

### ► ATTENTION

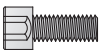
In the following step please pay attention that you don't clamp the cables between the frames.

3. Screw the console mast (11) to the main frame (1) with four washers (7), four spring washers (4), four screws (119) and hand tighten the screws in place.
4. Screw the rear cover (33) to the frame with two screws (96) and hand tighten the screws in place.

119		M8*1.25*25L	x4
4		D15.4*D8.2*2T	x4
7		D16xD8.5x1.2T	x4
96		ST4.2*15L	x2

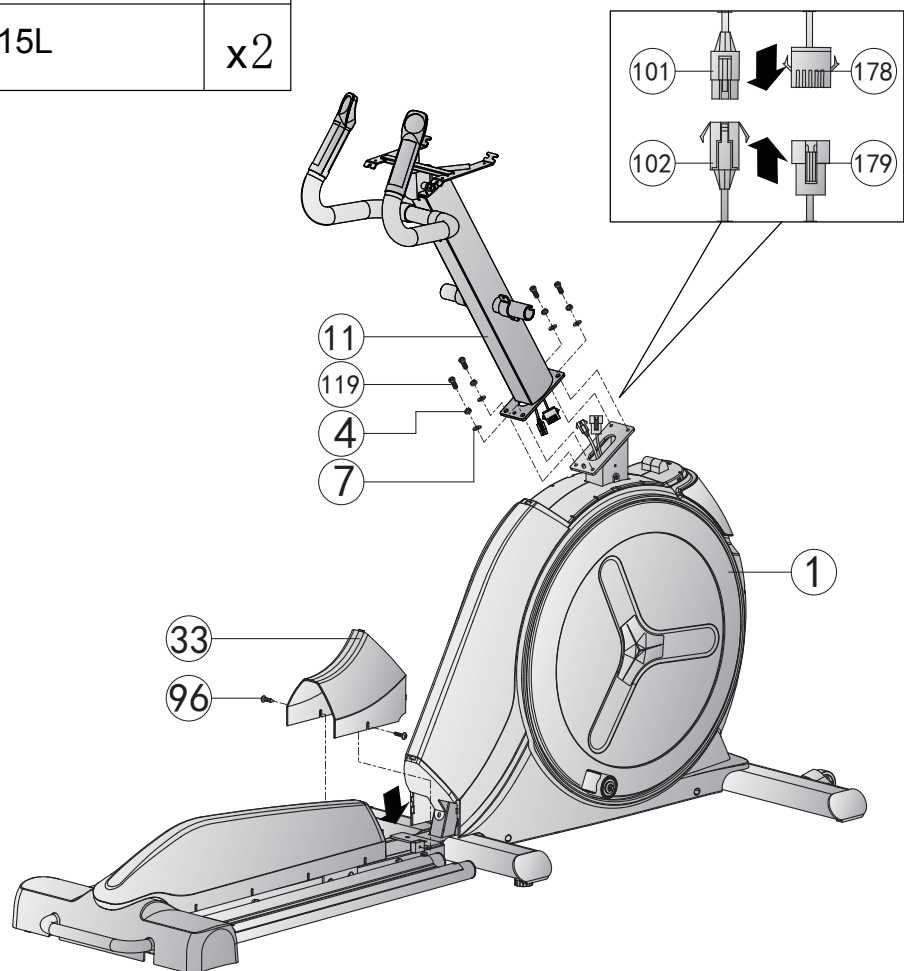

### Step 3: Mounting the arms

1. Screw the left arm (12L) onto the console mast (11) with two Allen screws (6).
2. Screw the right arm (12R) onto the console mast (11) with two Allen screws (6). Only hand tighten the screws in place.

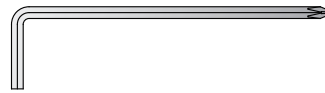

6		M8*1.25*20L	x4
---	--	-------------	----

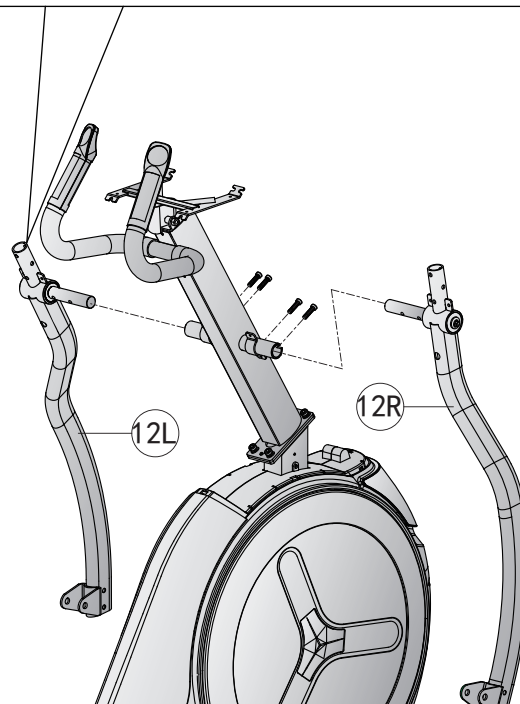
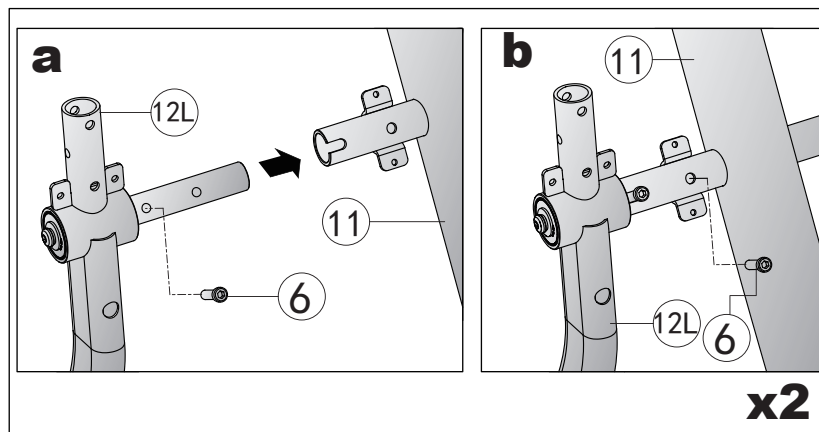







### Step 4: Mounting the pedals

1. Mount the right and left pedal poles (14R/14L) on their respective sides of the main frame (1), each with two washers (73), one Allen screw (72) and one locking nut (74) (see fig. 4-1).
2. Mount the right and left pedal mounts (15R/15L) on their respective arm (12R/12L), each with two washers (73), one Allen screw (72) and one locking nut (74) (see fig. 4-2).
3. Mount the right and left pedals (44) onto the pedal mounts (15R/15L), each with four screws (128) and place the pedal mats (45) on both pedals (44) (see fig. 4-3).
4. Only hand tighten the screws in place.



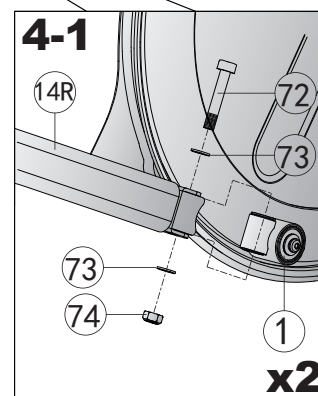
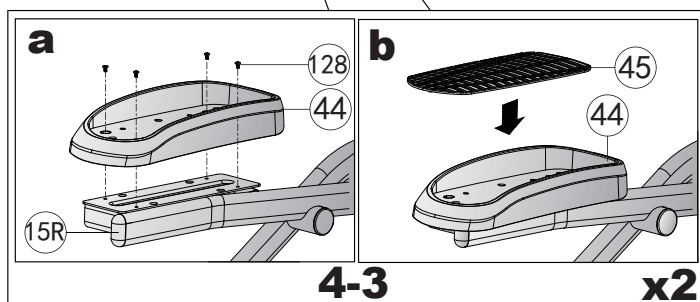
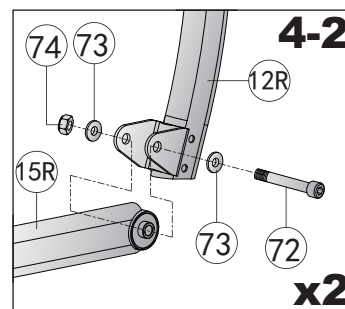
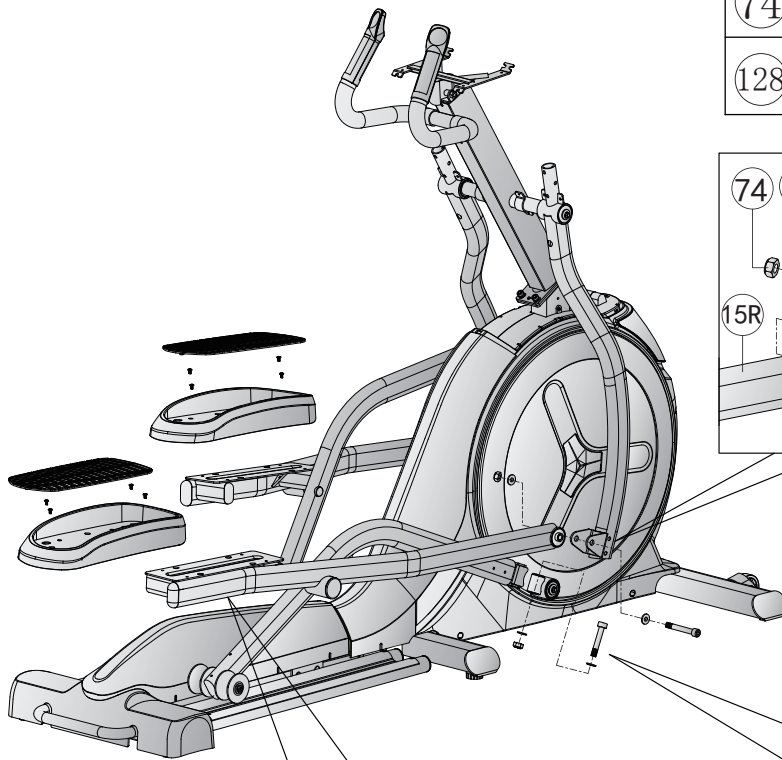

72		M12*1.75*70L	x4
73		D24*D13.5*D2.5T	x8
74		M12*1.75*12T	x4
128		M6*1.0*15L	x8



### Step 5: Mounting the handles

Screw the right and left handles (13R/13L) onto the respective arm (12R/12L), each with three curved washers (9), three Allen screws (8) and three locking nuts (10) (see figs. 5-1 & 5-2). Only hand tighten the screws in place.

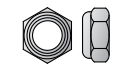
8	 M8*1.25*50L	x6
9	 D22*D8.5*1.5T	x6
10	 M8*1.25*8T	x6

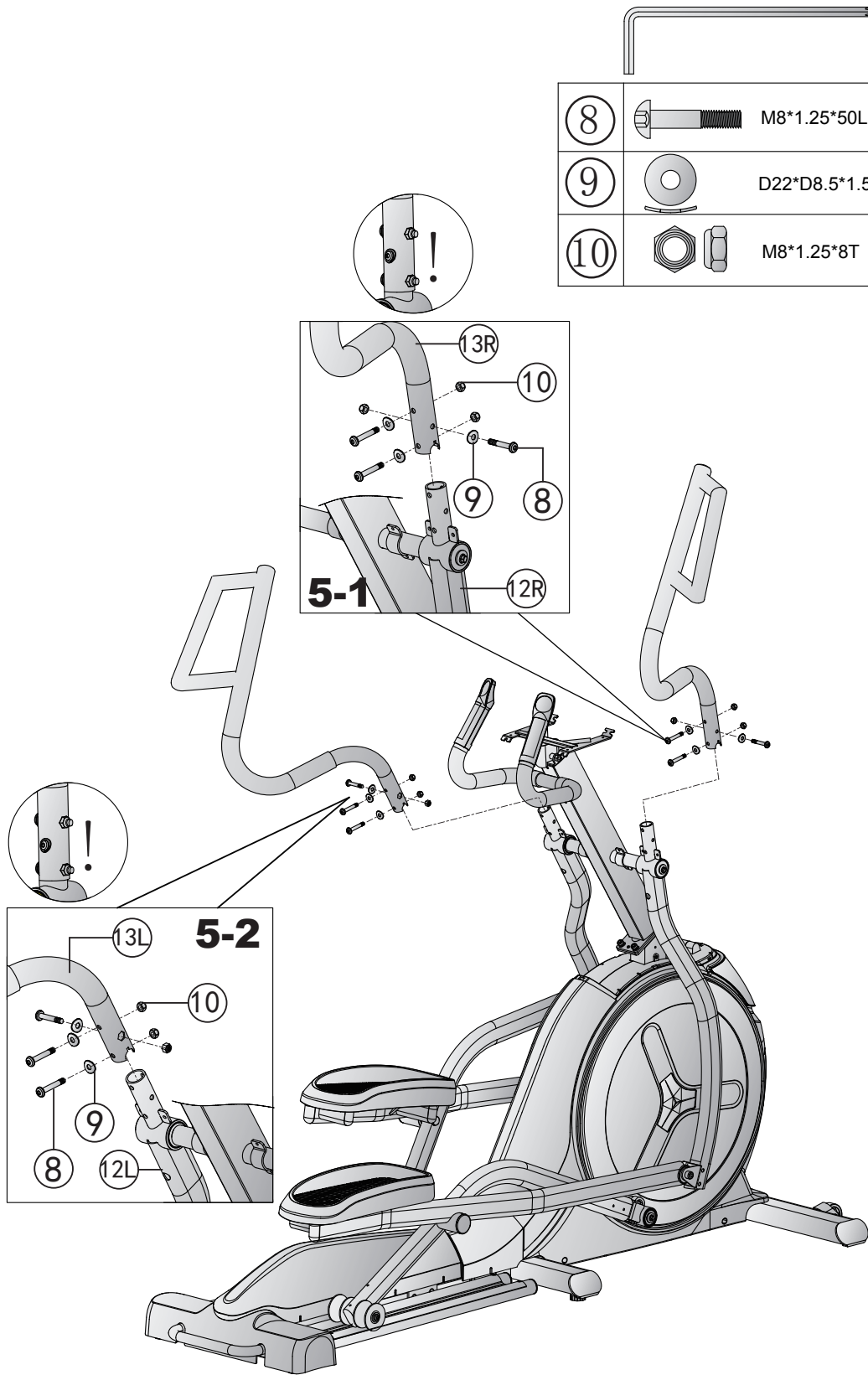

## Step 6: Mounting the console

1. Connect the console cable from the console (100) with the console cable from the console mast (101) (see fig. 6-1).
2. Connect the first hot-key cable from the console (106) with the first hot-key cable from the console mast (108) and the second hot-key cable from the console (107) with the second hot-key cable from the console mast (109) (see fig. 6-1).
3. Connect the signal cable from the console (177) with the signal cable from the console mast (178) (see fig. 6-1).

### ► ATTENTION

In the following step please pay attention that you don't clamp the cables between the frames.

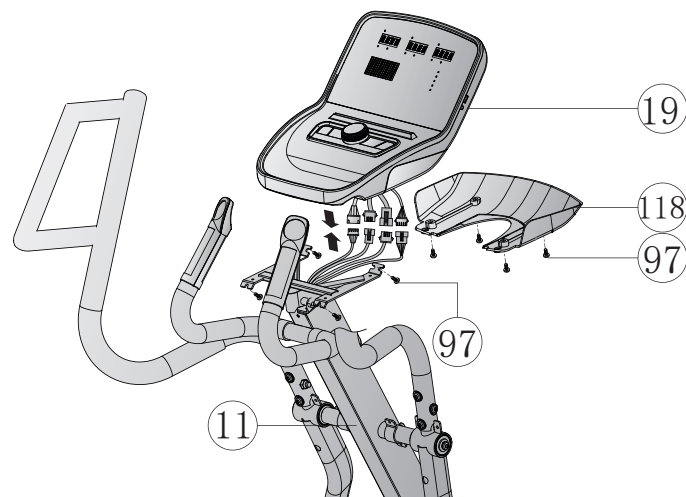
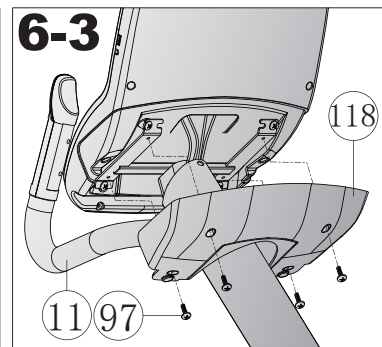
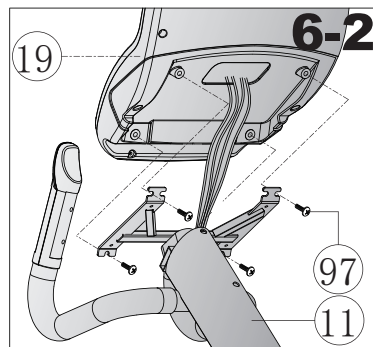
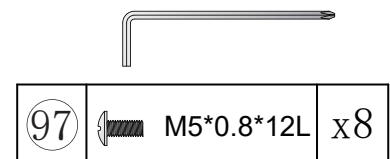
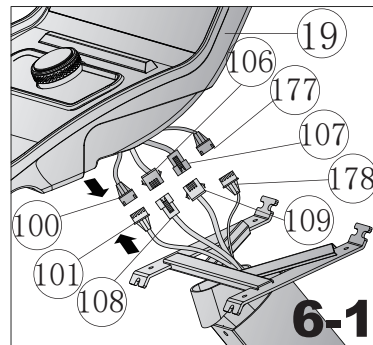

4. Screw the console (19) onto the console mast (11) with four screws (97) (see fig. 6-2) and hand tighten the screws in place.
5. Screw the cover (118) onto the console mast (11) with four screws (97) (see fig. 6-3) and hand tighten the screws in place.



## Step 7: Mounting the covers

1. Screw the front cover (99) under the console (19) onto the console mast (11) with two screws (96) and hand tighten the screws in place. Clip the rear cover (98) onto the front cover (99) (see fig. 7-1).
2. Screw the rear part of the water bottle holder (39) onto the console mast (11) with four screws (96) and hand tighten the screws in place. Clip the front cover of the water bottle holder (38) to the rear part (39) (see fig. 7-2).
3. Screw the front covers of the arms (64) onto both arms (12R/12L), each with two screws (96) (see fig. 7-3) and hand tighten the screws in place.
4. Clip the rear cover for the arms (65) onto the front cover (64) and screw it onto the arms (12R/12L), each with one screw (96) (see fig. 7-3).
5. Screw the left protective cover (30L) onto the main frame (1) with two screws (96) and one screw (97) and hand tighten the screws in place.
6. Clip the right protective cover (30R) onto the left protective cover (30L) and screw it onto the main frame (1) with one screw (97) (see fig. 7-4).
7. Screw the outer cover of the pedal mount (68R) onto the outer side of the pedal mount (15R/15L), each with two screws (96) and hand tighten the screws in place. Clip the inner cover (68L) onto the outer cover (68R) (see fig. 7-5).
8. Screw the wheel covers (63) on both sides of the crosstrainer, each with two screws (97) (see fig. 7-6) and hand tighten the screws in place.
9. Screw the axial covers (71) on both sides of the crosstrainer, each with two screws (97) (see fig. 7-7) and hand tighten the screws in place.



96		ST4.2*15L	x18
97		M5*0.8*12L	x10

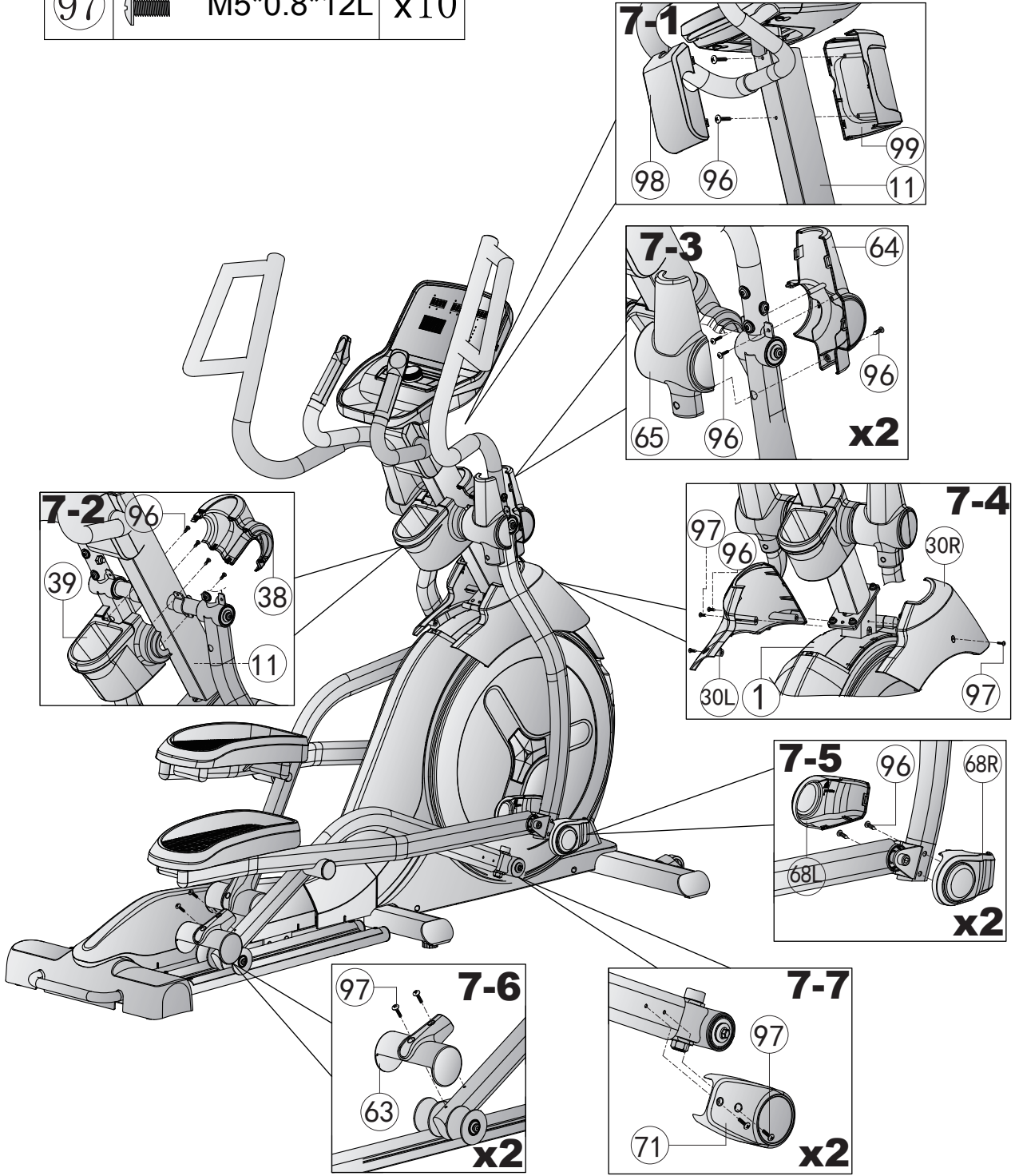

### Step 8: Adjusting the feet

The crosstrainer can be stabilised on un-even surfaces with the adjustable feet.

1. Lift up the crosstrainer on one side to gain access to the adjustable feet underneath the frame.
2. Turn the screw clockwise to unscrew the foot, lifting the crosstrainer at that point.
3. Turn the screw anti-clockwise to lower the crosstrainer at that point.

### Step 9: Connecting the crosstrainer to the mains supply

#### ▶ ATTENTION

The crosstrainer should not be plugged into a power board, as it cannot be guaranteed that the crosstrainer will be supplied with sufficient power. This could also lead to technical errors occurring.

Firstly connect the power cord (117) to the crosstrainer and then plug it into the wall socket, making sure the electrical prerequisites covered in the chapter about electrical safety are met.

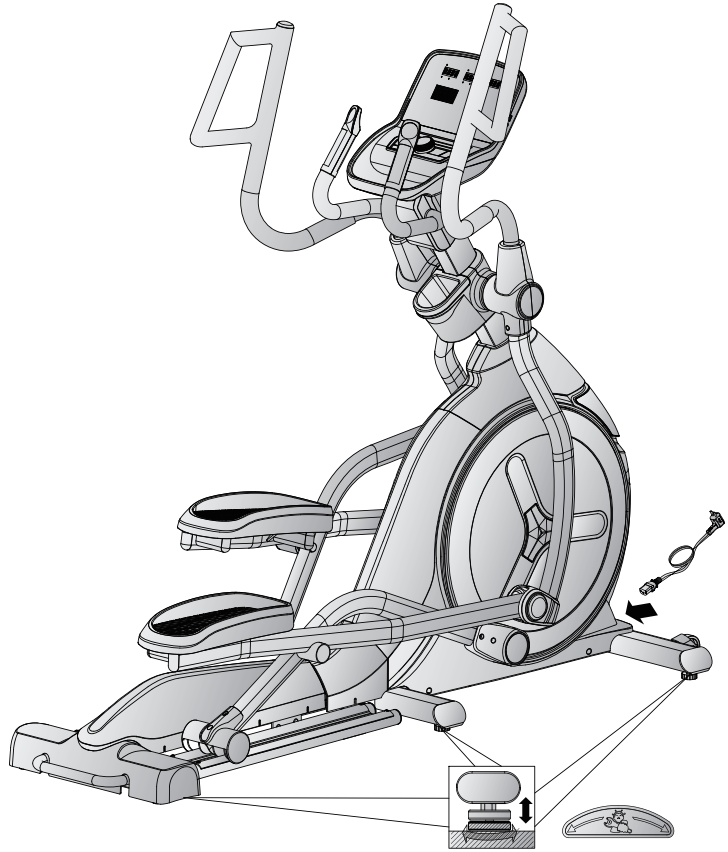

### Correctly Getting On and Off

1. To get on, grip the handles with both hands and first step onto the left pedal with your left foot or onto the right pedal with your right foot and then place your foot onto the other pedal.
2. To get off, grip the handles with both hands and place one foot next to the equipment and then the other foot.

## 3 OPERATING INSTRUCTIONS

### ① NOTICE

- + Familiarise yourself with all the functions and setting options of the device before starting training. Have the proper use of this product explained to you by a specialist.
- + Always start your training with low intensity and increase evenly and gently. End your training with a cool-down phase. If you are unsure, please consult your physician.

### 3.1 Console display

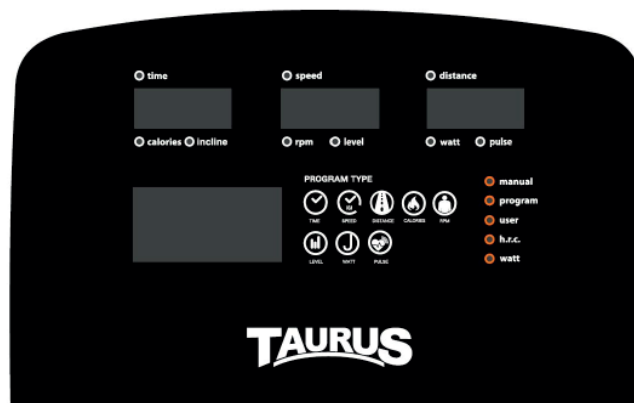

DISPLAY	DESCRIPTION
<b>TIME</b>	+ Display of the elapsed training time (0:00 - 99:59) + Set a target time with the rotary knob (0:00 - 99:00) in 1 min. increments
<b>SPEED</b>	Display of the current speed (max. 99.9)
<b>DISTANCE</b>	+ Display of the distance covered (0.00-99.99) + Set a target distance with the rotary knob (0.00-99.0) in 1km increments
<b>CALORIES</b>	+ Display of the calories burned (0-9999) + Set a target calorie value with the rotary knob (0-9999) in 10 Cal. increments
<b>RPM</b>	Display of the current revolutions per minute (RPM) (0-999)
<b>INCLINE</b>	+ Display of the current incline level (0-10) + Set the incline with the incline buttons (0-10) in 1 level increments
<b>LEVEL</b>	Display of the current resistance level
<b>WATTS</b>	Display of the Watt value (0 -999)
<b>PULSE</b>	+ Display of your heart rate (0-230) + Set a heart rate target with the rotary knob (0-30-230) in singular increments

## 3.2 Button functions

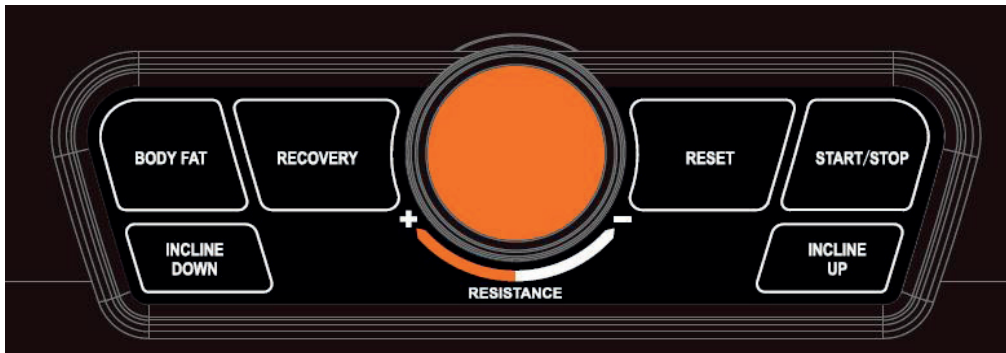

BUTTON	DESCRIPTION
<b>Rotary knob</b>	<ul style="list-style-type: none"><li>+ Increasing the setting value or resistance level</li><li>+ Decreasing the setting value or resistance level</li><li>+ Setting confirmation</li></ul>
<b>BODY FAT</b>	Body fat test
<b>RECOVERY</b>	Heart rate test on your recovery condition
<b>RESET</b>	Returns you to the previous training mode while making settings or selecting an option. To reset the console, press and hold the button for 2 seconds
<b>START/STOP</b>	Start and stop your training
<b>INCLINE DOWN</b>	Decreases the incline level
<b>INCLINE UP</b>	Increases the incline level



### 3.3 Powering on the crosstrainer

The console starts automatically as soon as the crosstrainer is plugged into the mains supply. Various components will light up.

1. Choose a user profile (U1 - U4).
2. Enter in your gender (SEX), age (AGE), height (HEIGHT) and weight (WEIGHT).

*You will proceed onto the main menu.*

In the main menu you can choose from the different programs.

- + MANUAL (Quick-Start and target programs)
- + PROGRAM (Profile programs)
- + USER PROGRAM (user defined program)
- + H.R.C (Heart rate controlled programs)
- + WATT (Watt program)



### 3.4 Standby mode

The console goes into standby mode after four minutes without inputs or movement. The console will exit standby mode as soon as it registers movement.

## 3.5 MANUAL (Manual programs)

Under MANUAL you can choose between the Quick-Start program and one of the target programs. For target programs, settings for time (TIME), distance (DISTANCE), calories (CALORIES) or heart rate (PULSE) are possible.

### 3.5.1 Quick-Start program

1. In the main menu, select MANUAL and confirm your choice with a single push of the rotary knob.
2. To start the Quick-Start program, just press the START/STOP button.

*Various values will start counting upwards.*

3. To pause the program, press the START/STOP button again.
4. To end the program, press the RESET button.



### 3.5.2 Target programs

You have two choices for target programs. The target program can have a singular or multiple targets set.

#### Training with a singular target value

1. In the main menu select MANUAL and confirm your choice with a single push of the rotary knob.
2. Select your target value for time, calories, distance or heart rate with the rotary knob and confirm your choice with a single push of the rotary knob.

#### **WARNING**

This crosstrainer is not medical equipment. The heart rate measurement of the crosstrainer can be unprecise. Different factors can influence the heart rate reading. The heart rate readings are only meant as a guide for training.

3. To start the program, press the START/STOP button.

#### **NOTICE**

During training it is possible to change the resistance level with the rotary knob.

*The target value counts down and the other values count upwards.*

4. To pause the program, press the START/STOP button again.
5. To end the program, press the RESET button.

## Training with multiple target values

1. In the main menu select MANUAL and confirm your choice with a single push of the rotary knob.
2. Select your target value for time, calories, distance and/or heart rate with the rotary knob and confirm your choice with a single push of the rotary knob.



### WARNING

This crosstrainer is not medical equipment. The heart rate measurement of the crosstrainer can be unprecise. Different factors can influence the heart rate reading. The heart rate readings are only meant as a guide for training.

3. To start the program, press the START/STOP button.

### NOTICE

During training it is possible to change the resistance level with the rotary knob.

*The target values count down and the other values count upwards.*

4. To pause the program, press the START/STOP button again.
5. To end the program, press the RESET button.

## 3.6 PROGRAM (Profile programs)

There are a total of 12 profile programs available to choose from.

1. In the main menu select PROGRAM and confirm your choice with a single push of the rotary knob.
2. Using the rotary knob select one of the profile programs and confirm your choice with a single push of the rotary knob.
3. Using the rotary knob select the training time and confirm the setting with a single push of the rotary knob.



4. To start the program, press the Um das Programm zu starten, drücken Sie die START/STOP-Taste.

### NOTICE

During training it is possible to change the resistance level with the rotary knob.

5. To pause the program, press the START/STOP button again.

### NOTICE

While the program is paused it is possible to change the training time.

6. To end the program, press the RESET button.

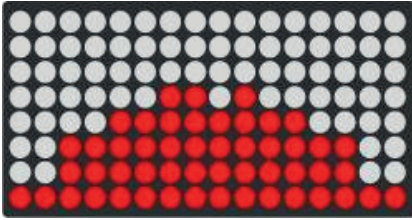

P1

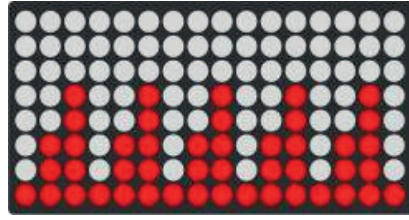

P2

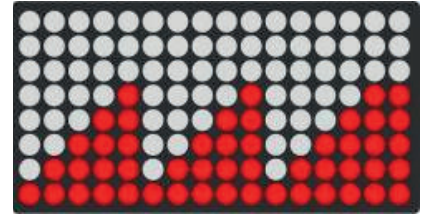

P3

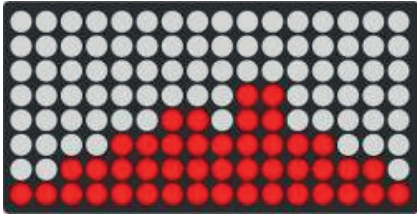

P4



P5



P6

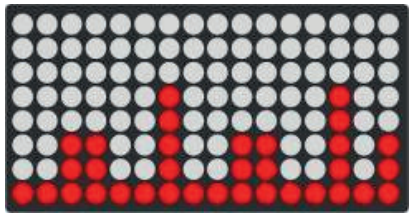

P7

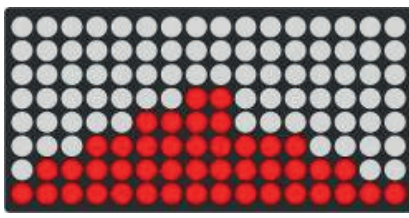

P8

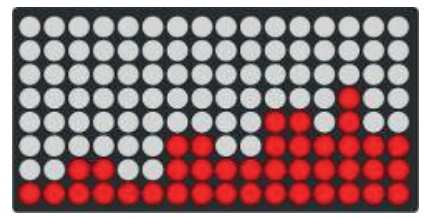

P9

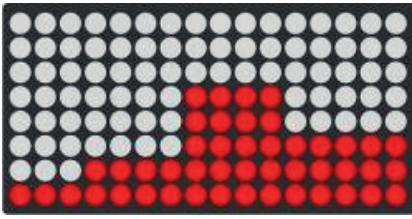

P10

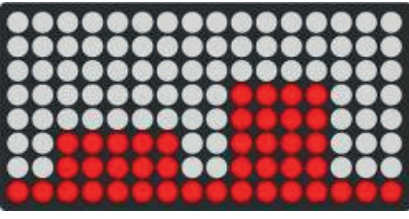

P11

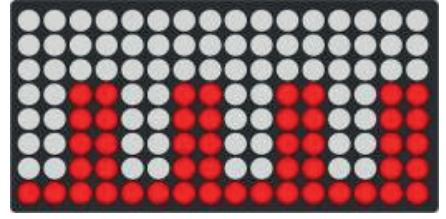

P12

### 3.7 USER (User defined program)

There are 16 segments available in user defined programs.

1. In the main menu select USER and confirm your choice with a single push of the rotary knob.
2. Select the resistance level of each segment and confirm each value with a single push of the rotary knob.
3. To end setting the resistance levels, press and hold the rotary knob for 2 seconds.



*The last set level is shown on the display.*

*You now have the option to set training time with the rotary knob.*

4. Using the rotary knob, select the training time and confirm the setting with a single push of the rotary knob or press the START/STOP button to directly start your training.

#### **NOTICE**

During training it is possible to change the resistance level with the rotary knob.

5. To pause the program, press the START/STOP button again.
6. To end the program, press the RESET button.

### 3.8 H.R.C. (Heart rate controlled programs)

**⚠ WARNING**

This crosstrainer is not medical equipment. The heart rate measurement of the crosstrainer can be unprecise. Different factors can influence the heart rate reading. The heart rate readings are only meant as a guide for training.

There are three heart rate programs available to choose from. You can choose from one of the three pre-set target heart rate programs (55%, 75% or 90% of your maximum heart rate) or choose TARGET and manually set a target heart rate value. Your maximum heart rate is calculated by the console and is dependant on your age set. We recommend using a chest heart rate sensor (chest strap) for this program.



1. In the main menu select H.R.C. and confirm your choice with a single push of the rotary knob.
2. Using the rotary knob select one of the pre-set target heart rate programs or TARGET and confirm your choice with a single push of the rotary knob.
3. If you have selected TARGET, use the rotary knob select a target heart rate and confirm your setting with a single push of the rotary knob.

**ⓘ NOTICE**

The pre-set TARGET value is 100.

- 3.1. Optionally you can also set a time and confirm this with a single push of the rotary knob.
4. To start the program, press the START/STOP button and hold the hand pulse sensors in your hands or alternatively you can use an optional chest strap.

*Your current heart rate will be displayed during training.*

**ⓘ NOTICE**

If no heart rate is detected, the display will show:



5. To pause the program, press the START/STOP button again.
6. To end the program, press the RESET button.

### 3.9 WATT (Watt program)

1. In the main menu select WATT and confirm your choice with a single push of the rotary knob.
2. Using the rotary knob, select a Watt value and confirm your setting with a single push of the rotary knob.



**NOTICE**

The pre-set value is 120.

3. Using the rotary knob select the training time and confirm the setting with a single push of the rotary knob or press the START/STOP button to directly start your training.

**NOTICE**

The resistance level changes automatically to the set Watt value.

4. To pause the program, press the START/STOP button again.
5. To end the program, press the RESET button.

### 3.10 RECOVERY (Recovery function)

Use the recovery function after a training session to measure your recovery heart rate.

To start the recovery function, press the RECOVERY button and hold the hand pulse sensors or alternatively use an optional chest strap.

*The display shows a countdown that runs from 00:60 to 00:00.*



**NOTICE**

If you wish to prematurely end the recovery function, press the RECOVERY button again.

Based on the final pulse readings, once the countdown ends you'll receive a fitness grade from F1 to F6.

F1	Very good
F2	Good
F3	Average
F4	Adequate
F5	Bad
F6	Very bad

### 3.11 BODY FAT (Body fat analysis)

1. Choose your user profile (U1-U4).
2. To start the body fat analysis, in the main menu press the BODY FAT button and hold on to the hand pulse sensors.

**NOTICE**

Should you not properly grip the hand pulse sensors, the display will show the error code E-1.

**NOTICE**

If you wish to prematurely end the body fat analysis and return to the previous program, press the BODY FAT button again.

After successfully ending the test you'll be shown your body fat ratio (FAT%) and your BMI.

**NOTICE**

Should your body fat ratio be outside of the 5% - 50%, the display will show the error code E-4.





### 3.12 Wireless Connection and Fitness Apps

This console is equipped with a wireless connection interface. Please take note that your mobile device needs to be compatible with the wireless connection interface of the treadmill.

To use training apps you will have to activate the wireless connection function on your mobile device (tablet or smart phone) and start the fitness app. Select your fitness equipment. Please follow the instructions given in the app. You will find the name of your fitness equipment on a small sticker on the back of the console.

You will find the fitness apps in the app stores of Google or Apple. There you will find the apps "Kinomap" or "Zwift". Please note that these apps are produced by an external manufacturer. Fitshop does not take any responsibility regarding the availability, functionality or contents of these programmes.

#### IMPORTANT NOTE

The pre-installed apps are produced and provided by external manufacturers. Changes and availability within these apps might occur. Fitshop does not take any responsibility and can not be held liable for the availability, functionality or contents of these apps. To make sure the pre-installed apps are working correctly, they must be updated regularly. If needed, the respective app will notify you to do so. To update the app, you need a google account. A google email is sufficient. Just follow the instructions on the screen to perform the update.

Please note: The system is set up only for the pre-installed apps. Do not install any additional apps as their proper functionality can not be guaranteed. The installation of other apps might cause technical issues.

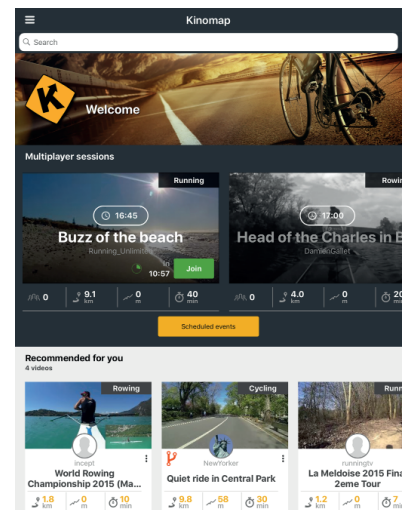
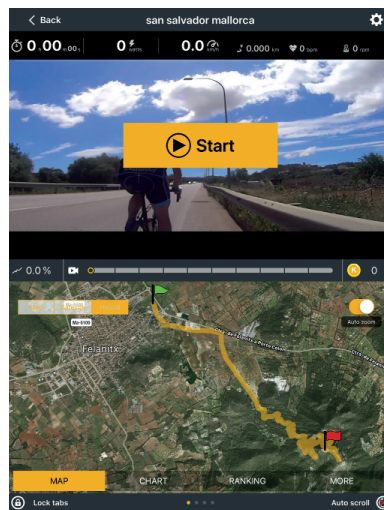
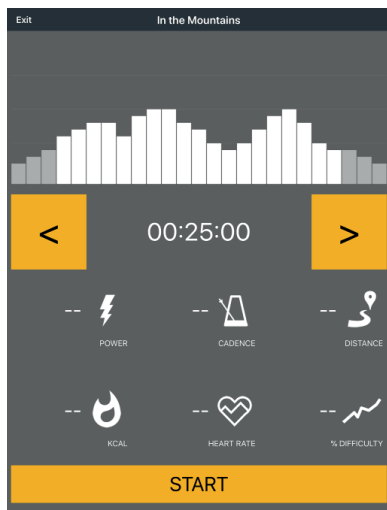

Example: Kinomap

## 4.1 General Instructions

### ▶ ATTENTION

- + Make sure that the equipment is protected from moisture, dust and dirt in the selected storage location. The storage location should be dry and well ventilated and have a constant ambient temperature between 5°C and 45°C.

### ⚠ WARNING

- + The storage location should be chosen so that improper use by third parties or children can be prevented.
- + If your equipment does not have transportation wheels, the equipment must be disassembled before transportation.

## 4.2 Transportation Wheels

### ▶ ATTENTION

If you want to transport your equipment over particularly sensitive and soft floor coverings, such as parquet, planks or laminate, lay out the transport route with cardboard or similar to avoid possible floor damage.

1. Stand behind the equipment and lift it until the weight is transferred to the transportation wheels. After that, you easily can move the equipment to a new position. For long transport distances the equipment should be disassembled and safely packed.
2. Select the new location by following the instructions in the section 1.4 of this manual.

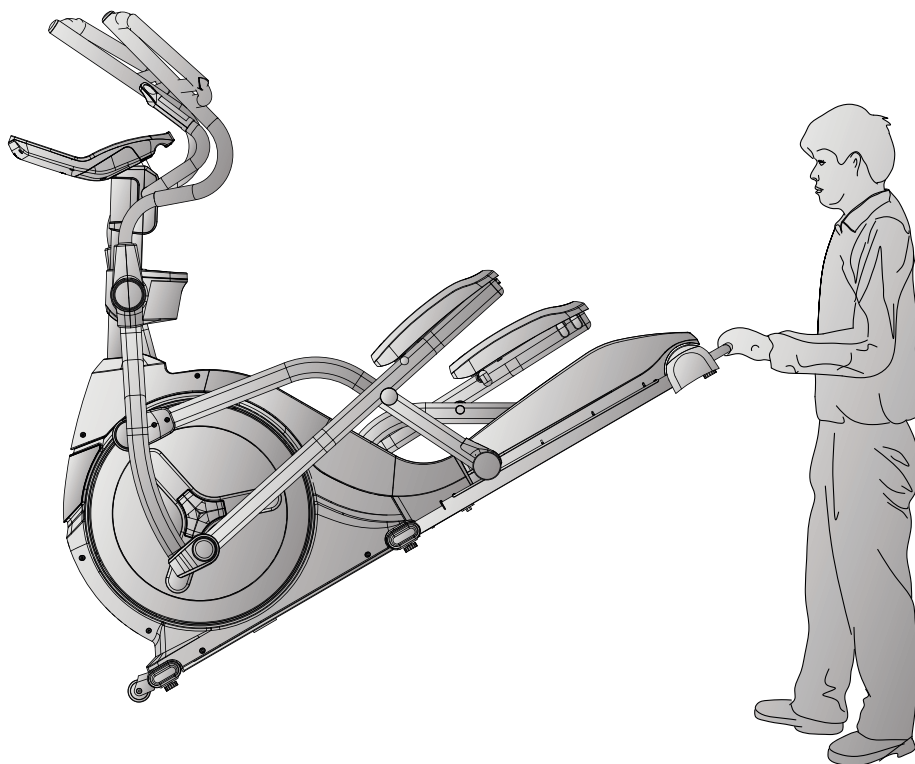

## 5.1 General Instructions



### WARNING

- + Do not make any improper changes to the equipment.



### CAUTION

- + Damaged or worn components may affect your safety and the life of the equipment. Therefore, immediately replace damaged or worn components. In such a case, contact the contract partner. The equipment must not be used until it has been repaired. If necessary, use only original spare parts.

### ▶ ATTENTION

- + In addition to the instructions and recommendations for maintenance and care given here, additional service and/or repair work may be necessary; this must only be carried out by authorised service technicians.

## 5.2 Faults and Fault Diagnosis

The equipment undergoes regular quality controls during production. Nevertheless, faults or malfunctions may occur. Frequently, individual parts are responsible for these disturbances, an exchange is usually sufficient. Please refer to the following overview for the most common errors and how to correct them. If the equipment still does not function properly, contact your contract partner.

Fault	Cause	Solution
The drive disc is wobbling or producing noises	Drive disc is loose	Tighten the nut
Display doesn't function	Cables not properly connected	Check all cable connections
Pedals are squeaking	Pedals are loose	Tighten the screws in the pedals
Squeaking noises	Screws have loosened	Check that all the screws are tightened
Rails are squeaking	The rails and/or wheels are dirty or the rails are dry	Clean the rails and wheels Re-lubricate the rails with fat-free silicon
No pulse displayed	<ul style="list-style-type: none"> <li>+ Source of interference in the room</li> <li>+ Chest strap is not compatible</li> <li>+ Position of the chest strap is incorrect</li> <li>+ Batteries are empty</li> </ul>	<ul style="list-style-type: none"> <li>+ Eliminate the source of interference (e.g. Mobile, Speakers, etc.)</li> <li>+ Use a compatible chest strap (see recommended accessories)</li> <li>+ Re-position the chest strap and/or moisten the electrode(s)</li> <li>+ Change the batteries</li> </ul>

## 5.3 Error codes and troubleshooting

The electronics of the crosstrainer are continually running tests. In case of deviations, an error code is shown on the display and normal operation is stopped for your safety.

- + E-1 No values were received during the body fat analysis. Make sure that, during the analysis, you hold on to the hand pulse sensors with both hands.
- + E-4 The user settings entered for age, height, weight or the body fat ratio is outside of the setting range.

## 5.4 Maintenance and inspection calendar

To avoid damages from sweat, the crosstrainer must be cleaned with a damp towel (no solvents!) after each training session.

The following routine tasks must be performed at the specified intervals:

Part	Weekly	Monthly	Quarterly
Display console	C	I	
Slide rails*		C	
Lubrication of slide rails and moving parts*			I
Plastic covers	C	I	
Screws and cable connections		I	
Legend: C = clean; I = inspect			

\*Make sure to always clean the slide rails and moving parts before re-lubricating.

By scanning the QR-code with the camera function or QR-code scanner app of your smartphone/tablet, a video on general maintenance of an exercise bike opens on YouTube. The video serves to illustrate the maintenance points described in this manual.

Please note that the video may not be available in your language or with appropriate subtitles.

If you cannot scan QR-codes, you can access all Fitshop videos on YouTube by first opening YouTube and entering "Fitshop" in the search field.



## 6 DISPOSAL

At the end of its operational life, this equipment cannot be disposed of in normal household waste. Instead, it must be disposed of via an electricals recycling centre. Further information can be obtained from your local authority's recycling service.



The materials can be recycled as per their symbols. Through the reuse, recycling of materials or other forms of recovery of old equipment, you make an important contribution to the protection of the environment.

## 7 RECOMMENDED ACCESSORIES

To make your training experience even more efficient and pleasant, we recommend that you add suiting accessories to your fitness equipment. This could be a floor mat, for example, which makes your fitness equipment stand more securely and also protects the floor from falling sweat, but it could also be additional handrails on some treadmills or silicone spray to keep moving parts in good shape.

If you have purchased a fitness machine with pulse training and want to train your heart rate, we strongly recommend that you use a compatible chest strap, as this ensures optimum transmission of the heart rate. You may want to buy additional grips or weights for multi gyms.

Our range of accessories offers the highest quality and makes training even better. If you would like to find out more about compatible accessories, please go to the detail page of the product in our webshop (the easiest way is to enter the article number in the search field above) and go to the recommended accessories on this page. Alternatively, you can use the QR-code provided. Of course, you can also contact our customer service: by telephone, e-mail, in one of our branches or via our social media channels. We will be happy to advise you!



floor mat



chest strap



chest strap contact gel



towels



silicone spray

## 8.1 Serial Number and Model Name

In order to provide you with the best possible service, please have the model name, article number, serial number, exploded drawing and parts list ready. The corresponding contact options can be found in chapter 10 of this operating manual.

**NOTICE**

The serial number of your equipment is unique. It's located on a white sticker. The exact position of this sticker is shown in the following illustration.

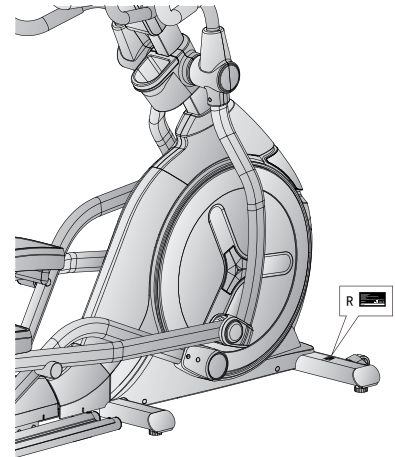

Enter the serial number in the appropriate field.

**Serial number:**

**Brand / Category:**

Taurus / Cross-Elliptical Trainer

**Model Name:**

FX9.9

**Article Number:**

TF-FX99

## 8.2 Parts List

No.	Name	Supplier Part No.	Specification	Qty.
1	main frame	747S1-3-1000-J0		1
2	front stabilizer	747S0-3-2100-J0		1
3	hex bolt	50108-5-0120-F5	M8*1.25*120L,8.8	2
4	spring washer	55108-2-1520-FA	D15.4xD8.2x2T	16
5	hex bolt	50108-5-0070-F4	M8*1.25*70L,8.8	2
6	allen bolt	54008-5-0020-F0	M8*1.25*20L,8.8	4
7	flat washer	55108-1-1612-FA	D16*D8.5*1.2T	4
8	allen bolt	50308-5-0050-F3	M8*1.25*50L,8.8	6
9	curved washer	55108-3-2215-FA	D22xD8.5x1.5T	6
10	anti-loose nut	55208-1-2008-FA	M8*1.25*8T	8
11	handlebar post welding	747A2-3-2000-J0		1
12L	supporting tube for left movable handlebar	747S0-3-3710-J0		1
12R	supporting tube for right movable handlebar	747S0-3-3711-J0		1
13L	left handlebar welding set	747S0-3-2430-J1		1
13R	right handlebar welding set	747S0-3-2450-J1		1
14L	left pedal bottom tube welding set	747A2-3-3810-J0		1
14R	right pedal bottom tube welding set	747A2-3-3811-J0		1
15L	bracket for left pedal	747S0-3-6000-J2		1
15R	bracket for right pedal	747S0-3-6025-J2		1
16	pedal bottom bracket welding set	747S0-3-3804-J2		2
17	foot tube sealing piece	747S0-6-2108-J0	104*63*4T	4
18	crank welding set	747S0-3-2700-J1		2
19	computer	747S1-6-2501-B0	SE-8627-71	1
20	sliding beam guiding plate	747A2-6-5171-00	126.9*720L*2.3T	2
21	adjustable wheel	74202-6-2174-N0	D50*M10*1.5	6
22	allen nut	55210-2-2008-NA	M10*1.5*8T	6
23	fixing plate for idle wheel	747S0-3-1600-00		1
24	electric magnetic system	747S0-3-3102-01	D265*153*50, SKF	1
25	crank axle welding set	747S0-3-2903-00		1
26	pulley Wheel	58008-6-1036-D0	D350*29.9*3T	1
27	multi-groove Belt	58004-6-1110-00	520 PJ8	1
28	C key	75000-6-3107-01	8*7*20L	2



29L	left chain	747S0-6-4501-B0	734.4*878.2*98.1	1
29R	right chain	747S0-6-4502-B0	734*878.2*105.2	1
30L	left front chain cover	747S0-6-4529-B1	459.7*225.5*87.2	1
30R	right front chain cover	747S0-6-4530-B1	459.7*225.5*93.8	1
31	front decorative cover	747S0-6-4523-B0	168.9*175.2*170.8	1
32	upper decorative cover	747S0-6-4520-B0	639*313.7*176.5	1
33	rear decorative cover	747A2-6-4521-B0	217.5*177.1*144.6	1
34	round chain	747S0-6-4506-B0	D632.9*36.7	2
35	side cap	747S0-6-4582-C0	148*130.3*16.1	2
36	cover for rear stabilizer	747S0-6-4542-B1	566.9*109.3*144.3	1
37	inside cover for rear stabilizer	747S0-6-4543-B0	503.5*59*44.6	1
38	water bottle holder(front)(black)	747S0-6-2091-B0	195*159*71.8	1
39	water bottle holder(rear)(black)	747S0-6-2092-B0	195*167.1*159.4	1
40	water bottle holder	747S0-6-2074-B0	113*138.3*120.5	1
41	upper handle pulse cover	747S0-6-2517-B0	184.5*20.8*50	2
42	lower handle pulse cover	747S0-6-2518-B0	184.5*35.2*50	2
43L	left dipped foam	58015-6-1386-B0	D38*4T	1
43R	right dipped foam	58015-6-1387-B0	D38*4T	1
44	pedal	58029-6-1147-B0	434.2*210.7*84	2
45	pedal pad	75000-6-3896-B0	379*168.5*5T	2
46	bearing	58006-6-1057-00	#6205ZZ,NBK	2
47	allen bolt	54010-8-0065-F6	M10*1.5*65L,12.9	2
48	hex nut	55210-A-2008-FA	M10*1.5*8T, 8.8	4
49	spacer	75000-6-2781-00	D32*D25.2*9T	1
50	hex bolt	50108-2-0020-U0	M8*1.25*20L	8
51	flat washer	55108-1-2520-FA	D25*D8.5*2T	20
52	buffer	739S0-6-1081-B0	D27*D8.2*2.5T	6
53	sleeve	747S0-6-2707-00	D30*D25.2*45L	1
54	fixing nut	75000-6-2807-N0	M25*1.5*32*6T	2
55	allen screw	54006-5-0010-F0	M6*1.0*10L,8.8	2
56	flat washer	55106-1-2820-FA	D28*D6.5*2T	2
57	allen screw	54006-5-0015-D0	M6*1.0*15L,8.8	4
58	flat washer	55106-1-1310-NA	D13*D6.5*1.0T	4
59	spring washer	55106-2-1013-NA	D10.5*D6.1*1.3T	4
60	movable axle	747S0-6-3771-00	D25*180.5L	2

61	moving wheel	73800-6-3886-B3	D70*43	4
62	bearing	58006-6-1032-00	6002 ZZ	8
63	moving wheel cover	74750-6-3897-B0	162*136.2*87	2
64	front handlebar protective cover(black)	74750-6-3780-B0	240.5*127.8*59	2
65	rear handlebar protective cover(black)	74750-6-3781-B0	240.5*127.8*50	2
66	bearing	58006-6-1017-00	#6004ZZ	12
67	sleeve(2)	74750-6-2788-00	D25.4*D20.2*44L	2
68L	front foot cover (left)(black)	74750-6-3775-B0	152.3*91.1*46.7	2
68R	front foot cover (right)(black)	74750-6-3776-B0	152.3*91.1*60	2
69	bushing	58002-6-1028-UC2	D29*D12.1*9T	4
70	liner	74750-6-2973-00	D25.4*D20.2*26L	2
71	front pedal axle cover	74750-6-3880-B0	182.4*95.7*67.6	2
72	allen screw	50412-8-0070-F4	M12*1.75*70L, 12.9	4
73	flat washer	55112-1-2425-FA	D24*D13.5*D2.5T	8
74	anti-loose nut	55212-1-2012-FA	M12*1.75*12T	4
75	bearing	58006-6-1031-00	#2203-2RS	2
76	c-clip	55540-3-0018-D0	S-40(1.8T) D40	2
77	bushing	58002-6-1092-00	D19*D17*D12*20T	4
78	sleeve	74750-6-5202-01	D25.4*D20.2*31L	2
79	cross screw	52606-2-0015-N0	M6*1*15L	8
80	cross screw	52842-2-0015-F0	ST4.2*15L	8
81	c-clip	55517-1-0010-00	S-17(1T)	1
82	waved washer	55117-5-2203--DA	D17*D22*0.3T	3
83	bearing	58006-6-1026-01	6203-2RS	2
84	anti-loose nut	55208-1-2008-NA	M8*1.25*8T	1
85	flat washer	55108-1-2115-CA	D21*D8.5*1.5T	1
86	hex nut	55208-2-2006-NA	M8*1.25*6T	1
87	hex bolt	50108-5-0030-C4	M8*1.25*30L,8.8,20L	1
88	plastic washer	55110-1-5010-BF	D50*D10*1.0T	1
89	anti-loose nut	55206-1-2006-CA	M6x1.0x6T	2
90	hex bolt	50106-2-0075-N0	M6*75L	1
91	fixing plate	815G0-6-1673-N0	20*27*4T	2
92	hex bolt	50106-5-0015-C0	M6x1.0x15L, 8.8	2
93	hex nut	55206-2-2005-NA	M6*1*5T	3
94	hex bolt	50108-5-0020-C0	M8x1.25x20L,8.8	4

95	anti-loose nut	55208-1-2008-CA	M8*1.25*8T	4
96	cross screw	52842-2-0015-F0	ST4.2*15L	61
97	cross screw	52605-5-0012-F0	M5*0.8*12L,8.8	37
98	computer bracket(front)	74750-6-2592-B0	196.4*109.5*49.1	1
99	computer bracket(rear)	74750-6-2593-B0	196.3*109.5*96.4	1
100	upper computer cable	74750-6-2572-00	300L	1
101	middle computer cable	74750-6-2587-00	900L	1
102	lower computer cable	74750-6-2573-00	1050L	1
103	system connect cable	82050-6-3177-00	350L	1
104	sensor cable	80550-6-2576-00	500L	1
105	round magnet	174R4-6-2574-00	M02	1
106	quick key upper cable(1)	74750-6-2542-00	300L	1
107	quick key upper cable(2)	74750-6-2539-00	300L	1
108	quick key lower cable(1)	74750-6-2544-00	850L	1
109	quick key lower cable(1)	74750-6-2536-00	850L	1
111	control board	74751-6-2597-00		1
112	switching mode power supplier	26100-6-2411-00		1
113	socket	26100-6-2413-00		1
114	live wire (1)	26200-6-1789-00	220L	1
115	neutral wire(2)	26200-6-1792-00	220L	1
116	grounding cable(2)	26200-6-1788-00	150L	2
117	electric cable	26100-6-1775-02	1700L	1
118	computer back cover	74750-6-2529-B0	337.6*225.5*58.4	1
119	allen bolt	54008-5-0025-F0	M8*1.25*25L,8.8	4
120	allen bolt	50308-5-0040-F3	M8*1.25*40L,8.8	2
121	transporting wheel	84302-6-2175-00	D70.5*23	2
122	bushing	58002-6-1099-00	D22.2*D8.2*7T	4
123	cross screw	54203-2-0030-F0	M3*0.5*30L	4
124	cross screw	54203-2-0012-F0	M3*0.5*12L	2
125	oval square	55315-3-3060-B8	30*60*15	2
126	buffer	74750-6-1081-B0	D21*D8.2*2.5T	4
127	spacer	74750-6-3892-00	D19*D15.2*25.5L	4
128	cross screw	52606-2-0015-F0	M6*1*15L	8
129	oval square	55328-3-2550-B1	25*50*28L,1.5T tube	4
130	square cap	55350-1-0015-B8	D50.8*15	2

143	rear cover	747A2-6-4514-B0	766.7*169.6*144.3	1
144	pin	71600-6-4586-60	D6*26.5*7.7	2
145	cross screw	52804-2-0012-F0	ST4*1.41*12L	3
146	rear stabilizer welding set	747A2-3-2112-J0		1
147	hex bolt	50108-5-0055-F3	M8*1.25*55L,8.8	4
148	hex bolt	50108-5-0035-F3	M8*1.25*35L,8.8	4
150	buffer	55308-4-0010-BB	D20*10L*M8*1.25	2
153	bushing	58002-6-1051-B0	D19.15x(D25.6x32) xL(17+3)	6
154	allen bolt	50308-5-0020-UF0	M8*1.25*20L,8.8	4
155	slide beam welding set	747A2-3-5100-J1		1
156	ball cap	55338-1-0031-B8	D38*31L	4
157	square cap	55312-2-2550-B8	25*50*12L,2.0 tube	2
158	incline	747A2-6-5172-00	JS17-B	1
159	hex bolt	50110-2-0075-F3	M10*1.5*75L	2
160	hex bolt	50110-2-0145-F6	M10*1.5*145L	1
161	flat washer	55110-1-2020-FA	D20*D11*2T	3
162	anti-loose nut	55210-1-2010-FA	M10*1.5*10T	3
163	bolt cover	19100-6-3172-B0	D35*8	2
164	circumgyrate axle	747A2-6-2751-00	D19*490.5L	1
165	incline control cable(1)	747A2-6-3481-00	500L	1
166	incline control cable(2)	747A2-6-3482-00	500L	1
167	VR control cable	747A2-6-3475-00	500L	1
171	neutral wire	747A2-6-3479-00	900L	1
172	live wire	747A2-6-3480-00	900L	1
176	computer Fixing Plate	747A2-3-2725-J0		1
177	signal upper cable	747S1-6-2563-00	300L	1
178	signal middle cable	747S1-6-3486-00	900L	1
179	signal lower cable	747S1-6-2564-00	1150L	1
180	button membran	747S1-6-2534-00	D39	1
181	button membran	747S1-6-2533-00	D39	1
/	allen spanner	58030-6-1031-D1	M6 8.8	1
/	open spanner	58030-6-1050-C0	153*6.5T	1
/	spanner	58030-6-1005-N2	121*D6	1
	allen spanner	58030-6-1033-N0	M10	1

# 8.3 Exploded Drawing

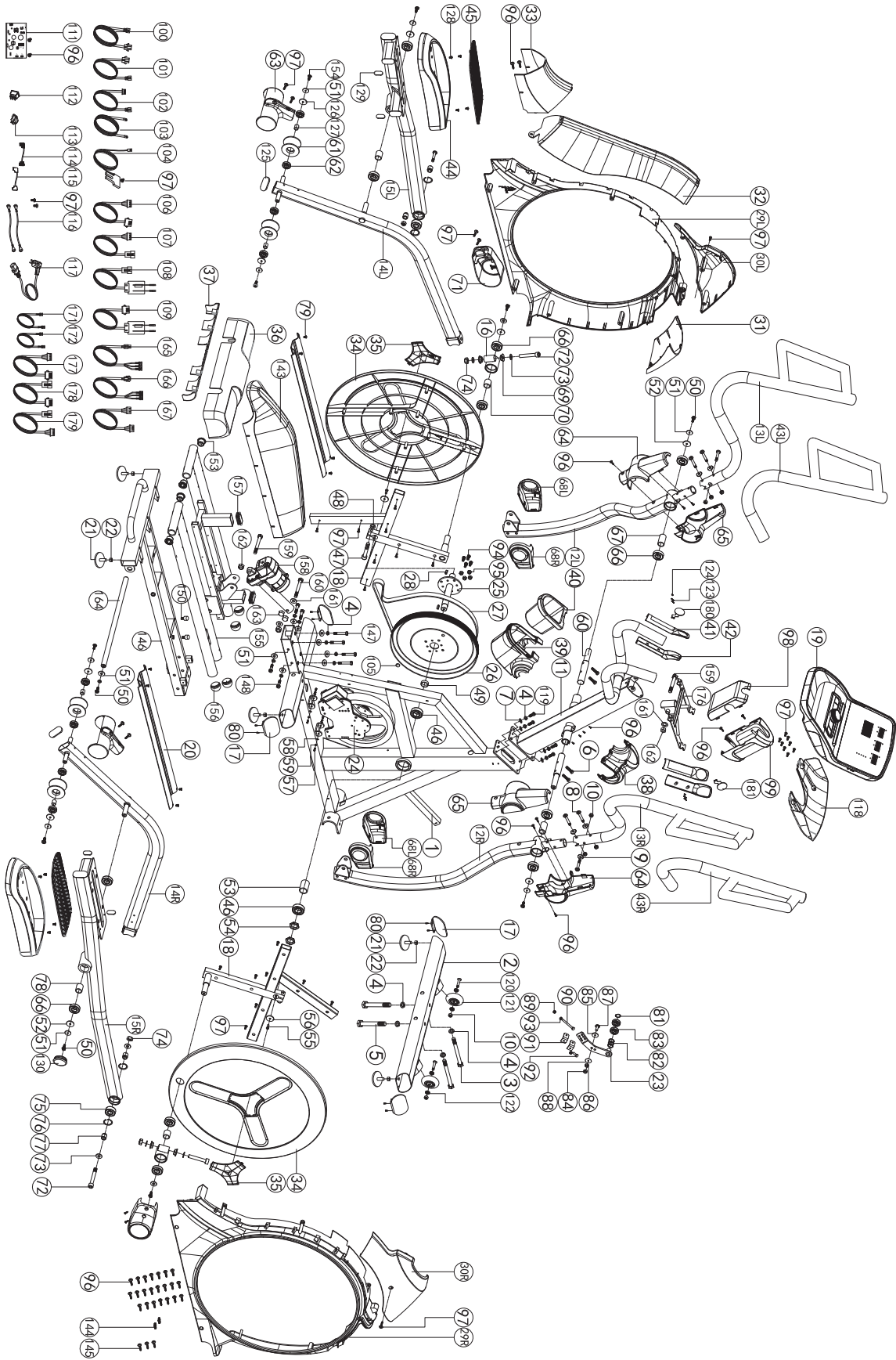

Products from TAURUS® are subject to strict quality control. However, if a fitness equipment purchased from us does not work perfectly, we take it very seriously and ask you to contact our customer service as indicated. We are happy to help you by phone via our service hotline.

### **Error Descriptions**

Your fitness equipment is developed for long-term, high-quality training. However, should a problem arise, please first read the operating instructions. For further assistance, please contact your contract partner or call our service hotline. To ensure your problem is solved as quickly as possible, please describe the defect as exactly as possible.

In addition to the statutory warranty, we provide a warranty for every fitness equipment purchased from us according to the following provisions.

**Your statutory rights are not affected.**

### **Warrantee**

The warrantee is the first/original buyer and/or any person who received a newly purchased product as a gift from the original buyer.

### **Warranty period**

The warranty periods, shown on our web shop, begin on delivery of the fitness equipment. The respective warranty periods for your equipment can be found on its product website.

### **Repair Costs**

According to our choice, there will either be a repair, a replacement of individual damaged parts or a complete replacement. Spare parts, that have to be mounted while assembling the equipment, have to be replaced by the warrantee personally and are not a part of repair. After the expiration of the warranty period, the responsibility for parts costs, repair costs, installation costs and delivery costs lies with the warranty holder.

### **The terms of use are defined as follows:**

- + Home use: solely for private use in private households up to 3 hours per day
- + Semi-professional use: up to 6 hours per day (e. g. rehabilitation centres, hotels, clubs, company gyms)
- + Professional use: more than 6 hours per day (e. g. commercial gyms)

### **Warranty Service**

Within the warranty period, equipment which develops faults as a result of material or manufacturing defects, will be repaired or replaced at our discretion. Ownership of equipment or parts of equipment which have been replaced is transferred to us. The warranty period is not extended nor does a new warranty period begin following repair or replacement under the warranty.

## **Warranty Conditions**

For the warranty to be valid, the following steps must be taken:

Please contact our customer service by email or phone. If the product under warranty has to be sent in for repair, the seller bears costs. After expiry of the warranty, the buyer bears the costs of transport and insurance. If the fault is covered by our warranty, you will receive a new or repaired equipment in return.

### **Warranty claims are invalid in case of damage resulting from:**

- + misuse or improper handling
- + environmental influences (moisture, heat, electrical surge, dust, etc.)
- + failure to follow the current safety measures for the equipment
- + failure to follow the operating instructions
- + use of force (e. g. hitting, kicking, falling)
- + interventions which were not carried out by one of our authorized service centres
- + unauthorised repair attempts

### **Proof of Purchase and Serial Number**

Please make sure that you are able to provide the appropriate receipt when claiming on your warranty. So that we can clearly identify the model of your equipment, and for the purposes of our quality control, you will need to give the serial number of your equipment, when contacting the service team. Where possible please have your serial number and your customer number ready when you call our service hotline. It will help us to deal with your request swiftly.

If you cannot find the serial number on your fitness equipment, our service team is at your disposal to offer further information.

### **Service outside of the Warranty Period**

We are also happy to issue an individual cost estimate if there is a problem with your fitness equipment after the warranty has expired, or in cases which do not fall under the terms of the warranty, e. g. normal wear and tear. Please contact our customer service team to find a quick and cost-effective solution to your problem. In such a case you will be responsible for the delivery costs.

### **Communication**

Many problems can be solved just by speaking to us as your specialist supplier. We know how important it is to you as a user of the fitness equipment to have problems solved quickly and simply, so you can enjoy working out with minimal interruption. For that reason, we also want to resolve your queries quickly and in a straightforward manner. Thus, please always keep your customer number and the serial number of the faulty equipment handy.

DE	DK	UK
<p><b>TECHNIK</b></p> <p>☎ +49 4621 4210-900 ☎ +49 4621 4210-698 ✉ technik@fitshop.de 🕒 Öffnungszeiten entnehmen Sie unserer Homepage.</p> <p><b>SERVICE</b></p> <p>☎ 0800 20 20277 (kostenlos) ☎ 04621 4210 - 0 ✉ info@fitshop.de 🕒 Öffnungszeiten entnehmen Sie unserer Homepage: <a href="https://stg.fit/statita">https://stg.fit/statita</a></p>	<p><b>TEKNIK OG SERVICE</b></p> <p>☎ 80 90 16 50 ☎ +49 4621 4210-945 ✉ info@fitshop.dk 🕒 Åbningstider kan findes på hjemmesiden: <a href="https://stg.fit/statit7">https://stg.fit/statit7</a></p>	<p><b>CUSTOMER SUPPORT</b></p> <p>☎ 00800 2020 2772 ☎ +494621 4210 944 ✉ info@fitshop.co.uk 🕒 You can find the opening hours on our homepage: <a href="https://stg.fit/statitic">https://stg.fit/statitic</a></p>
	FR	BE
	<p><b>TECHNIQUE &amp; SERVICE</b></p> <p>☎ +33 (0) 189 530984 ☎ +49 4621 42 10 933 ✉ info@fitshop.fr 🕒 Vous trouverez les heures d'ouverture sur notre site Internet: <a href="https://stg.fit/statit4">https://stg.fit/statit4</a></p>	<p><b>TECHNIQUE &amp; SERVICE</b></p> <p>☎ 02 732 46 77 ☎ +49 4621 4210 933 ✉ info@fitshop.be 🕒 Vous trouverez les heures d'ouverture sur notre site Internet: <a href="https://stg.fit/statit8">https://stg.fit/statit8</a></p>
ES	NL	INT
<p><b>TECNOLOGÍA Y SERVICIOS</b></p> <p>☎ 911 238 029 ✉ info@fitshop.es 🕒 Consulta nuestro horario de apertura en la página web: <a href="https://stg.fit/statit5">https://stg.fit/statit5</a></p>	<p><b>TECHNISCHE DIENST &amp; SERVICE</b></p> <p>☎ +31 172 619961 ✉ service@fitshop.nl 🕒 De openingstijden vindt u op onze homepage: <a href="https://stg.fit/statit3">https://stg.fit/statit3</a></p>	<p><b>TECHNICAL SUPPORT &amp; SERVICE</b></p> <p>☎ +49 4621 4210-944 ✉ service-int@fitshop.de 🕒 You can find the opening hours on our homepage: <a href="https://stg.fit/statita">https://stg.fit/statita</a></p>
PL	AT	CH
<p><b>DZIAŁ TECHNICZNY I SERWIS</b></p> <p>☎ 22 307 43 21 ☎ +49 4621 42 10-948 ✉ info@fitshop.pl 🕒 Godziny otwarcia można znaleźć na stronie głównej: <a href="https://stg.fit/statit6">https://stg.fit/statit6</a></p>	<p><b>TECHNIK &amp; SERVICE</b></p> <p>☎ 0800 20 20277 (Freecall) ☎ +49 4621 42 10-0 ✉ info@fitshop.at 🕒 Öffnungszeiten entnehmen Sie unserer Homepage: <a href="https://stg.fit/statitb">https://stg.fit/statitb</a></p>	<p><b>TECHNIK &amp; SERVICE</b></p> <p>☎ 0800 202 027 ☎ +49 4621 42 10-0 ✉ info@fitshop.ch 🕒 Öffnungszeiten entnehmen Sie unserer Homepage: <a href="https://stg.fit/statit9">https://stg.fit/statit9</a></p>

Please find a detailed overview including address and opening hours for all stores of the Fitshop Group in Germany and abroad on the following website:

[www.fitshop.com/en/stores](http://www.fitshop.com/en/stores)



# WE LIVE FITNESS

## WEBSHOP AND SOCIAL MEDIA

Fitshop is Europe's largest specialist store for home fitness equipment with currently over 70 stores and one of the world's most renowned online mail order companies for fitness equipment. Private customers order via the 25 web shops in the respective national language or have their desired equipment assembled on site. In addition, the company supplies fitness studios, hotels, sports clubs, companies and physio practices with professional equipment for endurance and strength training.

Fitshop offers a wide range of fitness equipment from renowned manufacturers, high-quality in-house developments and comprehensive services, such as a build-up service and sports scientific advice before and after the purchase. The company employs numerous sports scientists, fitness trainers and competitive athletes.

Visit us also on our social media platforms or our blog!

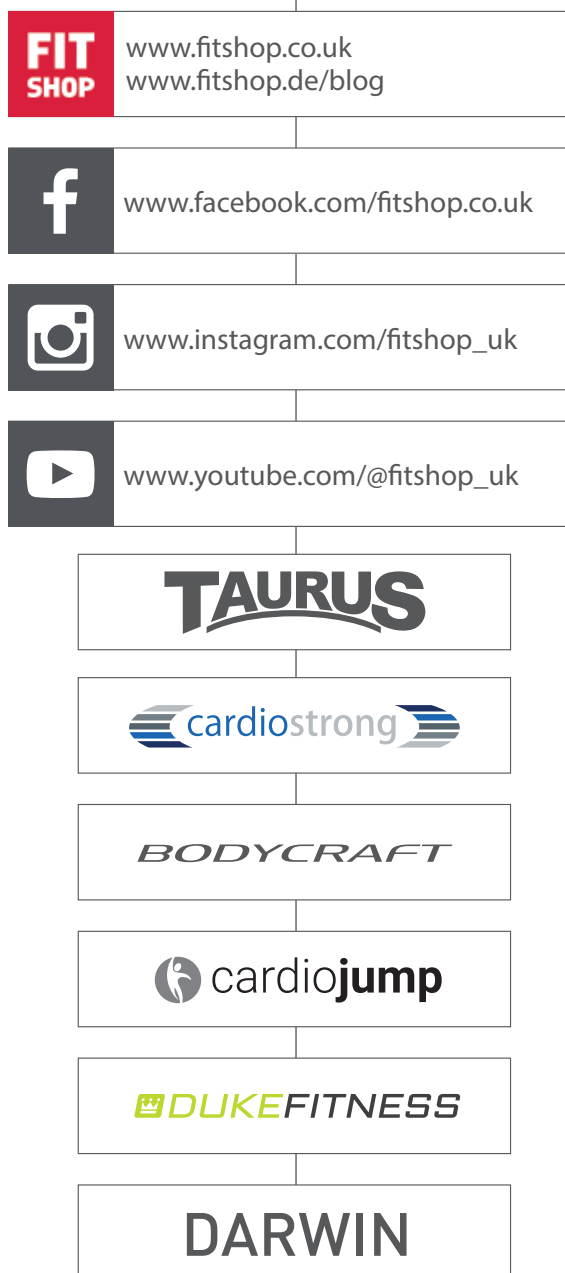

Notes



# **TAURUS<sup>®</sup>**

**Elliptical Trainer FX9.9**