

TAURUS®

Owner's Manual



TF-IT9504

PECTORAL IT95

TAURUS® is a registered brand of the company Fitshop GmbH.
All rights reserved. Any use of this trademark without the explicit written permission of Fitshop is prohibited.

Table Of Contents

CAUTION!

Read all precautions and instructions in this manual before using this equipment.

Important Safety Instructions-----	3
Instructions-----	5
Exploded View and Parts List-----	6
Measurement Guide-----	18
Assembly Instructions-----	19
Assembly-----	20
Adjust Instructions-----	36
Exercise Instructions-----	36
Maintenance Schedule-----	37
General Maintenance Information-----	38
Weight Training Tips-----	39

FITSHOP

Europe's No.1 for Home Fitness

Please assemble according to the actual **Weights and Shroud** you buy !

Important Safety Instructions

Before beginning any fitness program, you should obtain a complete physical examination from your physician. When using exercise equipment, basic precautions should always be taken, including the following:

1. Read all instructions before using the equipment.
These instructions are written to ensure your safety and to protect the unit.
2. Use the equipment only for its intended purpose as described in this guide.
Do not use accessory attachments that are not recommended by the manufacturer: such attachments might cause injuries.
3. The product should only be used on a level surface and is with 0.5 meters space around the product.
Do not use the equipment outdoors.
4. Do not allow children on or near the equipment. And children are not allowed to use this equipment.
Teenagers should use this equipment with adult supervision.
5. Do not overexert yourself or work to exhaustion.
Do not attempt to lift more weight than you can control safely.
If you feel any pain or abnormal symptoms, stop your workout immediately and consult your physician.
6. This equipment is not used as medical apparatus and instruments.
7. Never operate the unit when it has been dropped or damaged.
Never drop or insert anything into any opening in the equipment.
Always check the unit and its cables before each use. Make sure that all fasteners and cables are secure and in good working condition.
Frayed or worn cables can be dangerous and may cause injury. Periodically check these cables for any indication of wear.
Keep hands, limbs, loose clothing and long hair well out of the way of moving parts.
8. Be careful when getting on or off the equipment.
9. Wear proper exercise clothing and shoes for your workout, no loose clothing.

Important Safety Instructions

Personal Safety During Assembly

Read each step in the assembly instructions and follow the steps in sequence. Do not skip ahead. If you skip ahead, you may learn later that you have to disassemble components and that you may have damaged the equipment.

Assemble and operate the equipment on a solid, level surface. Locate the unit a few feet from walls or furniture to provide easy access. The equipment is designed for your enjoyment. By following these precautions and using common sense, you will have many safe and pleasurable hours of healthful exercise with the equipment.

Training Area and Free Area

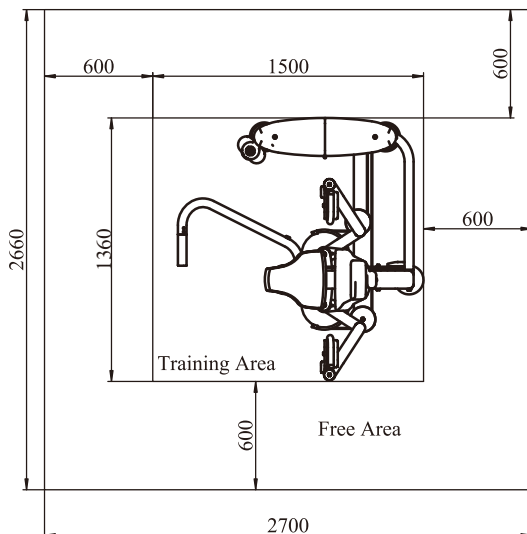

Specifications

Class: S

Maximum Wt. Capacity: 134kg/ 295lbs

Maximum User Weight: 150kg/ 330lbs

Product Dimension: 1450*1360*1510mm

Product Total Surface: 1500*1360mm

Product Total Mass: 145.2kg/ 320lbs

Instructions

Before beginning assembly please take the time to read instructions thoroughly. Please use the various lists in this manual to make sure that all parts have been included in your shipment. When ordering, use part number and description from the lists. Use only our replacement part when servicing. Failure to do so will void your warranty and could result in personal injury.

The equipment is designed to provide the smoothest, most effective exercise motion possible. After assembly, you should check all functions to ensure correct operation. If you experience problems, first recheck the assembly instructions to locate any possible errors made during assembly. If you are unable to correct the problem, call your authorized dealer. Be sure to have your serial number and this manual when calling. When all parts have been accounted for, continue on.

Tools Required

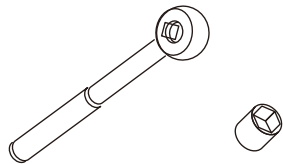

Ratchet Wrench and Socket

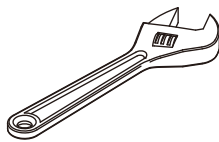

Adjustable Wrench



Rubber Mallet



Hex Key Wrench Set

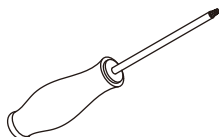

Phillips Screwdriver

Exploded View and Parts List

Overall

Item No.	Grade No.	Part No.	Description	QTY
1	1	IT950101ASSY	Weight Stack Frame ASSY	1
2	2	IT950121ASSY	Top Bracket ASSY	1
3	3	IT950122ASSY	Bottom Bracket ASSY	2
4	4	IT95012300	Rear Bracket	1
5	5	IT95014200	Top Plate	1
6	6	IT95014400	Guide Rod Φ 19*1242	2
7	7	IT95015100	Top Cover	1
8	8	IT95015200	Training Placard Cover	1
9	9	IT95015500	Top Rear Shroud	1
10	10	IT95016600	Cup Holder	1
11	11	IT950401ASSY	Main Frame ASSY	1
12	12	IT95040200	Bottom Cross Brace	1
13	13	IT950403ASSY	Right Arm Frame ASSY	1
14	14	IT950404ASSY	Left Arm Frame ASSY	1
15	15	IT950405ASSY	Right Swing Frame ASSY	1
16	16	IT950406ASSY	Left Swing Frame ASSY	1
17	17	IT950407ASSY	Startup Frame ASSY	1
18	18	IT950408ASSY	Connection Frame	2
19	19	IT95040900	Rear Connection Frame	1
20	20	IT95041000	Fixing Frame	1
21	21	IT95012400	Double Pully Bracket	1
22	22	IT95041100	Tension Cable ASSY	1
23	23	IT95041200	Startup Cable ASSY	1
24	24	IT95120800	Cable ASSY	1
25	25	IT95041400	Cable Connection Frame	1
26	26	IT95041500V1	Right-rotated Spring	1
27	27	IT95041600V1	Left-rotated Spring	1
28	28	IT95016000	Plastic Cover	1
29	29	IT95016400	Pulley Cover	1
30	30	IT95057800	Thin 4.5" Pulley	2
31	31	SD1000B3000ASSY	Adjustable Foot Plate	2
32	32	SG500110400V5	4.5" Pulley	7
33	33	IT95041300	Arm Pad	2
34	34	IT950171ASSY	Back Pad ASSY	1
35	35	IT950172ASSY	Head Pad ASSY	1
36	36	IT95017600	Seat Pad	1
37	37	IT95042000	Arm Pad Shroud	2
38	38	IT95015300	Front Shroud	1
39	39	IT95015400	Right Front Shroud	1
40	40	IT95015600	Rear Shroud	1
41	41	IT90012000V1	Selector Pin W/Coil	1

Exploded View and Parts List

Overall

Item No.	Grade No.	Part No.	Description	QTY
42	42	IT80023000	Weight Rubber Bumper	2
43	43	IT95016100	Guide Rod Fixing SleeveΦ25*Φ19*45	2
44	44	FE97212000	Circle Ring Φ62.5*5	1
45	45	FE97211900	Cap Φ60	1
46	46	HFOPT900-04A0602	Spring	2
47	47	FE97122300	Threaded Column	1
48	48	FE97122100	Pulley Spacer1	2
49	49	FE97193400	Pulley Spacer	1
50	50	SG-8005A2100	Bushing Φ31	4
51	51	IT95081900	Support Sleeve	2
52	52	FS552300	Rubber BumperΦ63.5	2
53	53	IT95016500	Spout Plug Φ16.5*6.88	2
54	54	GB818M6*20DHS2	Cross Recessed Pan Head Screw M6*20	18
55	55	GB818M6*10DHS2	Cross Recessed Pan Head Screw M6*10	4
56	56	GB818M6*16DHS2	Cross Recessed Pan Head Screw M6*16	4
57	57	GB70M4*15*15DN2	Flat Head Cap Screw M4*15	3
58	58	GB70M8*20N19	Flat Head Cap Screw M8*20	2
59	59	PNLM8*20DHS2	Button Head Cap Screws M8*20	2
60	60	GB70BTM10*25DN18	Socket Head Cap Screw M10*25	5
61	61	GB70BTM10*30DN18	Socket Head Cap Screw M10*30	6
62	62	GB70BTM10*50DN18	Socket Head Cap Screw M10*50	5
63	63	GB70BTM10*75DN18	Socket Head Cap Screw M10*75	6
64	64	GB70BTM10*80DN18	Socket Head Cap Screw M10*80	6
65	65	GB70BTM12*30DN18NL	Socket Head Cap Screw M12*30	2
66	66	GB70BTM12*135DN18NL	Socket Head Cap Screw M12*135	4
67	67	GB958DN2	Flat Washer Φ9*Φ16*1.6	2
68	68	GB9510DN2	Flat Washer Φ11*Φ20*2	38
69	69	GB9512DN2	Flat Washer Φ13*Φ24*2.5	12
70	70	DQ10DN2C	Flat Washer Φ11*Φ30*2	2
71	71	NM10DN2	Nylon Lock Nut M10	15
72	72	NM12DN2	Nylon Lock Nut M12	4
73	73	NBS3DHS	Hex Key S=3	1
74	74	NBS6DHS	Hex Key S=6	1
75	75	NBS8DHS	Hex Key S=8	1
76	76	LW200BS	Wrench Φ6*117	1
77	77	YHY	Lube	1
110	110	L1-3800V1	6" Pulley	1
111	111	GB70BTM12*60DN18	Socket Head Cap Screw M12*60	2
112	112	IT95042100	Polly Cover Plate	1
113	113	FE97021800	Threaded Column	1
200	200	IT9501C3100	Half Rear Shroud	1

Exploded View and Parts List

Overall

Full Shroud

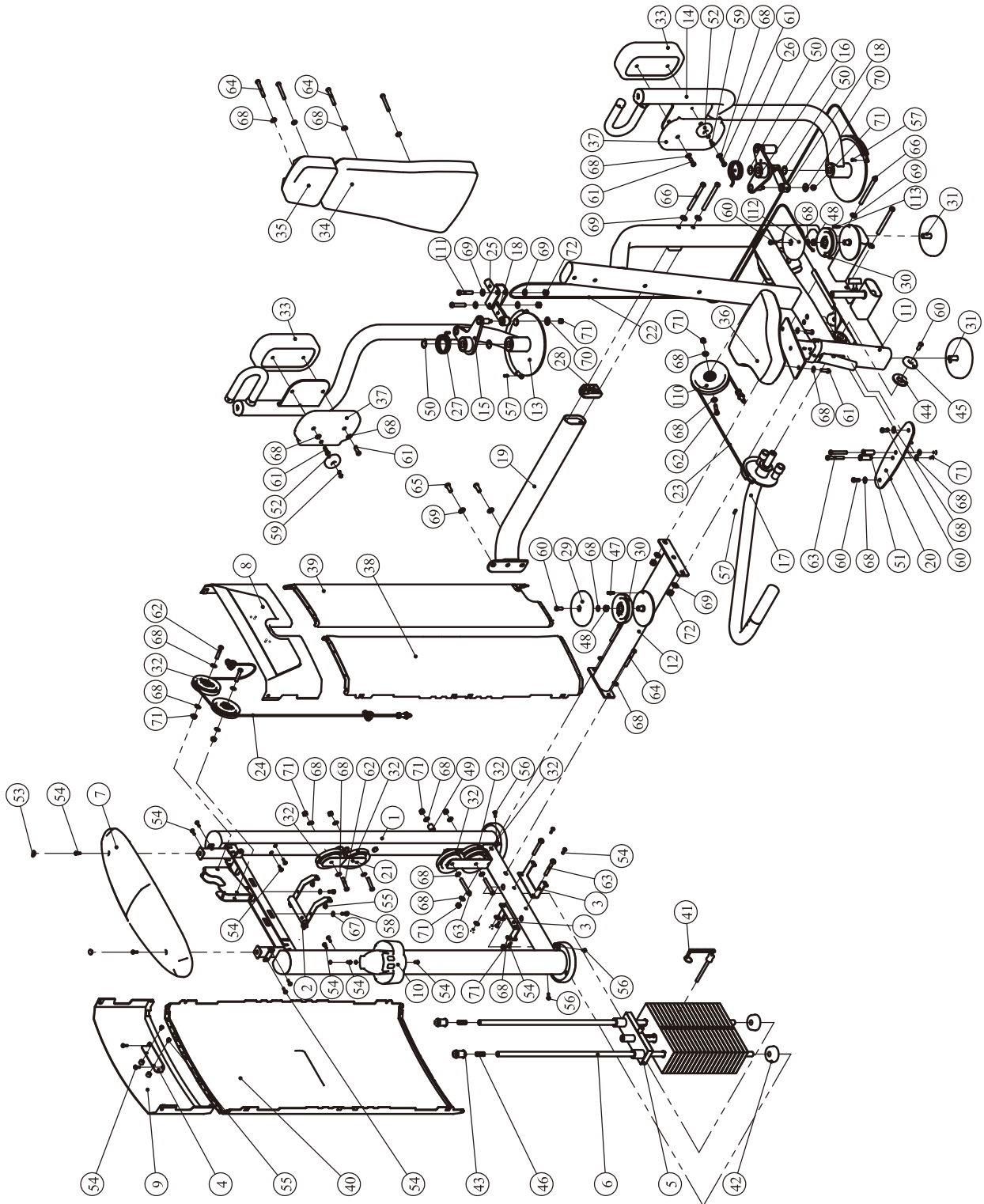

Exploded View and Parts List

Overall

Half Rear Shroud

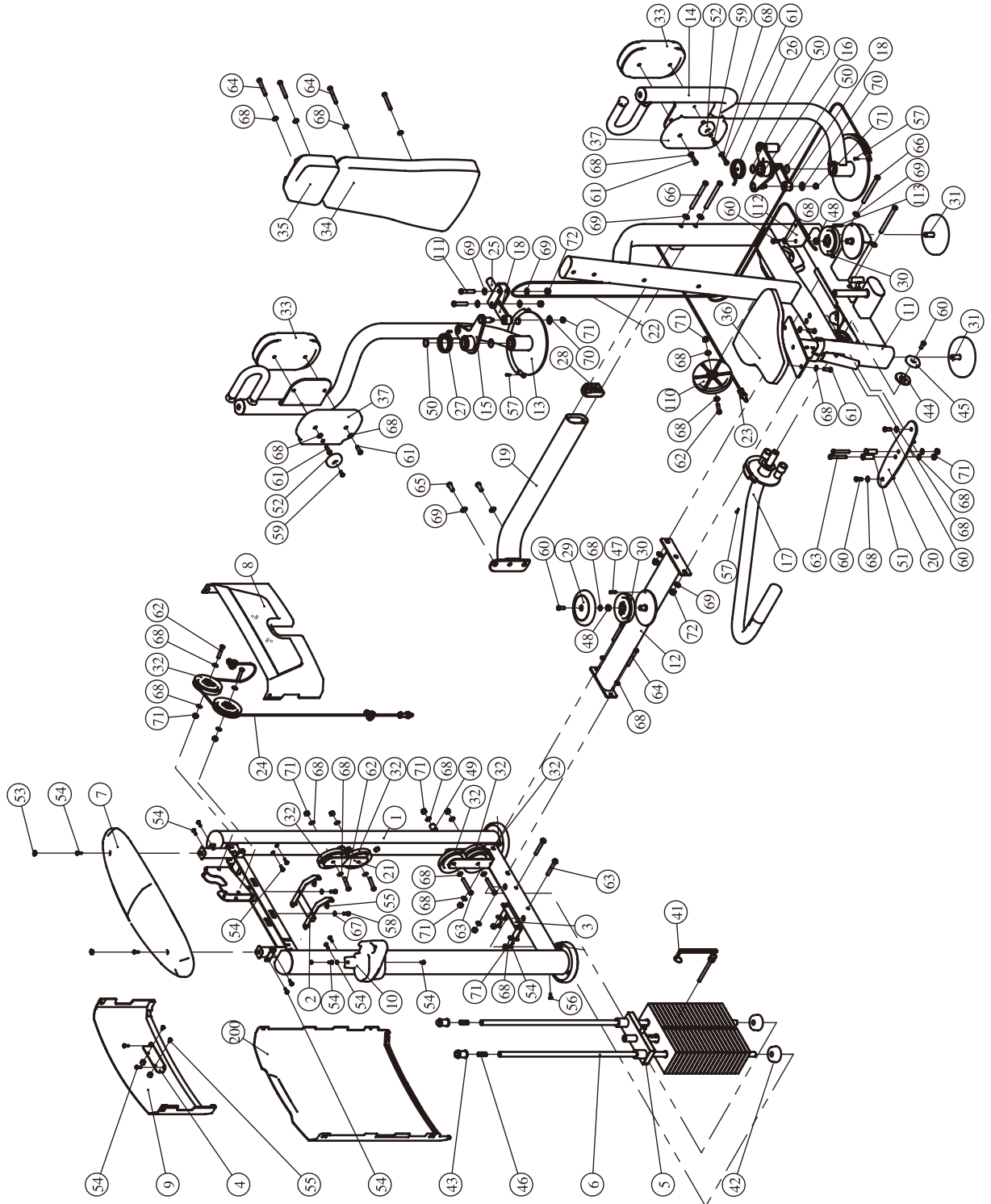

Exploded View and Parts List

Weight Stack Frame ASSY

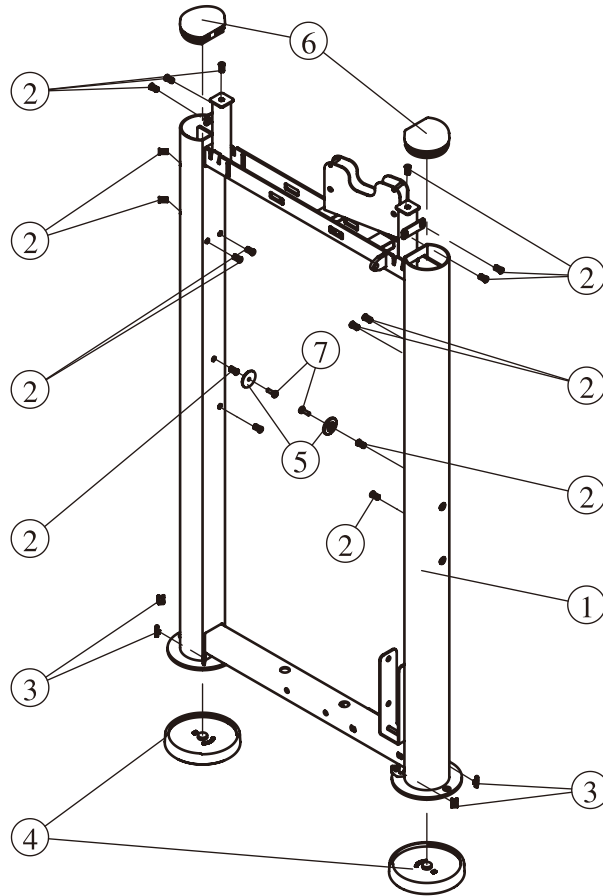

Item No.	Grade No.	Part No.	Description	QTY
1	1.1	IT95010100	Weight Stack Frame	1
2	1.2	GB17880.5M6*16.5DS17	Rivet Nut M6	16
3	1.3	AC32705800	U-nut M6	4
4	1.4	IT95015700	Foot Plate	2
5	1.5	IT95015900	Plastic Block	2
6	1.6	IT95015800	Plug $\Phi 95 \times 81.1$	2
7	1.7	GB818M6*20DHS2	Cross Recessed Pan Head Screw M6*20	2

Exploded View and Parts List

Startup Frame ASSY

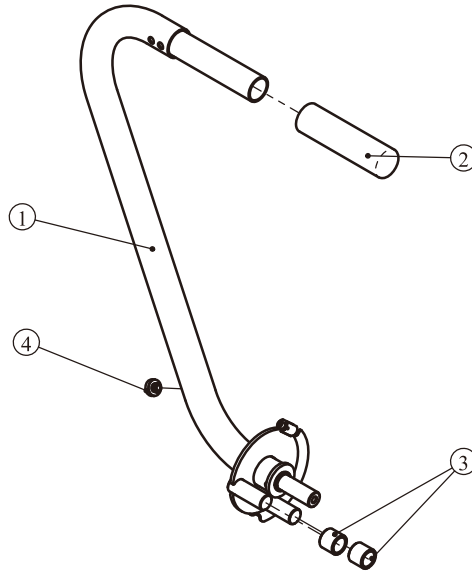

Item No.	Grade No.	Part No.	Description	QTY
1	17.1	IT95040700	Startup Frame	1
2	17.2	FE970112000	Foot Set	1
3	17.3	IN-D51202800	Rubber Sleeve $\Phi 32 \times 25.5$	2
4	17.4	ROC-IT1012400	Rubber Bumper $\Phi 25$	1

Connection Frame ASSY

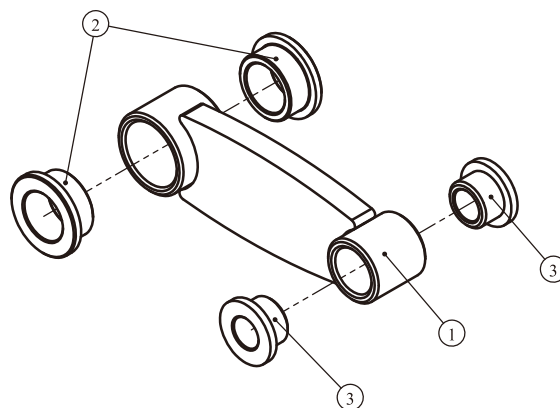

Item No.	Grade No.	Part No.	Description	QTY
1	18.1	IT95040800	Connection Frame	1
2	18.2	HVCORE5300	Bushing $\Phi 19$	2
3	18.3	M01402000	Bushing $\Phi 12$	2

Exploded View and Parts List

Left Swing Frame ASSY

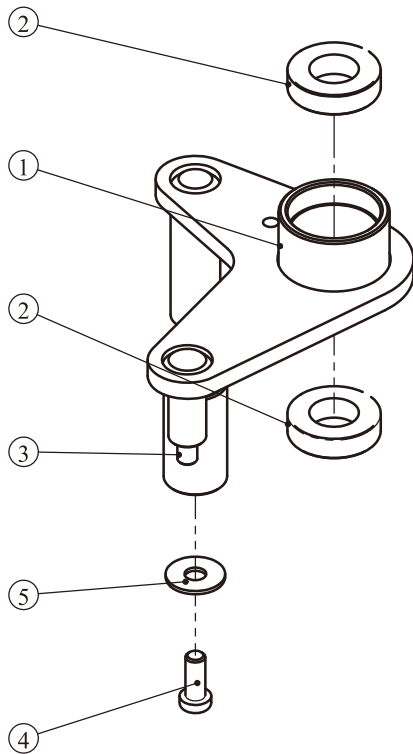

Right Swing Frame ASSY

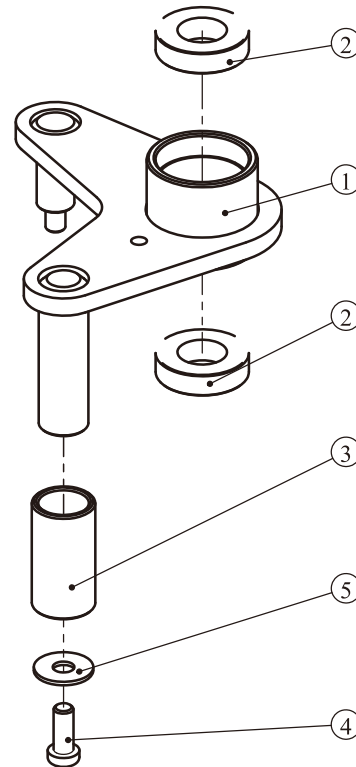

Item No.	Grade No.	Part No.	Description	QTY
1	16.1	IT95040600	Left Swing Frame	1
2	16.2	GB2766005-2RSC3NBK	Bearing	2
3	16.3	IT80044000	Rubber Sleeve $\Phi 32 \times 25.5$	1
4	16.4	GB70BT M10*25DN18	Socket Head Cap Screw M10*25	1
5	16.5	DQ10DN2C	Flat Washer $\Phi 11 \times \Phi 30 \times 2$	1

Item No.	Grade No.	Part No.	Description	QTY
1	15.1	IT95040500	Right Swing Frame	1
2	15.2	GB2766005-2RSC3NBK	Bearing	2
3	15.3	IT80044000	Rubber Sleeve $\Phi 32 \times 25.5$	1
4	15.4	GB70BT M10*25DN18	Socket Head Cap Screw M10*25	1
5	15.5	DQ10DN2C	Flat Washer $\Phi 11 \times \Phi 30 \times 2$	1

Exploded View and Parts List

Main Frame ASSY

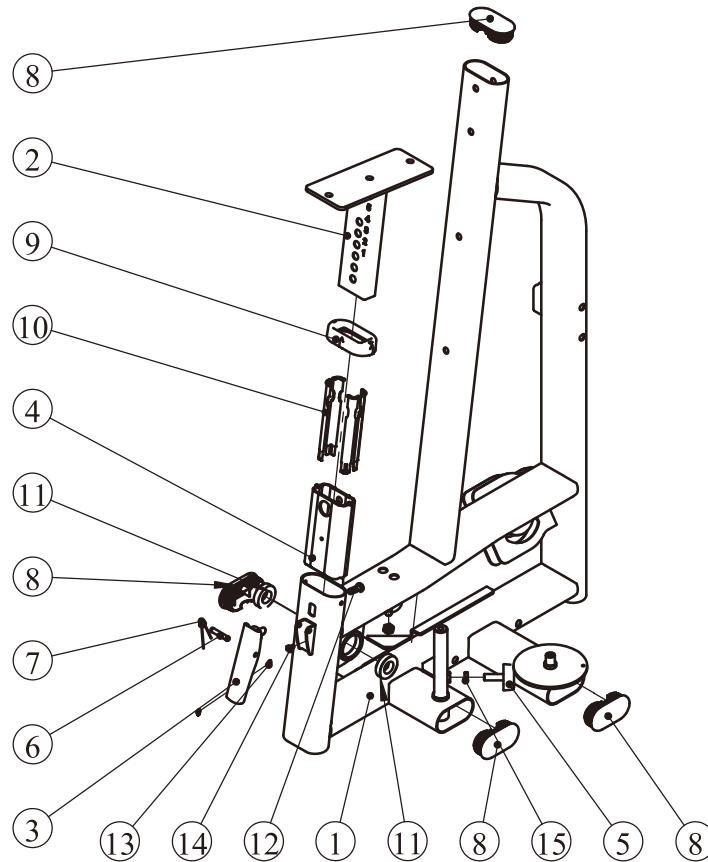

Item No.	Grade No.	Part No.	Description	QTY
1	11.1	IT95040100	Main Frame	1
2	11.2	IT95120900	Seat Pad Support	1
3	11.3	IT95014500	Adjustable Support	1
4	11.4	IT95014300	Aluminum Tube Guide	1
5	11.5	IT95122200	Plastic Plug	2
6	11.6	CWRVL0012200	Roll Pin	1
7	11.7	AXT3S5500	Torsional Spring	1
8	11.8	IT90013800P11C	Plug RT50*100	4
9	11.9	IT95016200	Plastic Tube Plug	1
10	11.10	IT95016300	Plastic Corner Tube Glide	4
11	11.11	GB2766005-2RSC3NBK	Bearing	2
12	11.12	GB70BTM10*25DN18	Socket Head Cap Screw M10*25	1
13	11.13	GB894.18FH12	Circlips For Shaft Φ 8	2
14	11.14	GB70M6*10N19	Socket Head Cap Screw M6*10	1
15	11.15	GB6172.1M12DN2	Hexagon Thin Nut M12	2

Exploded View and Parts List

Back Pad ASSY

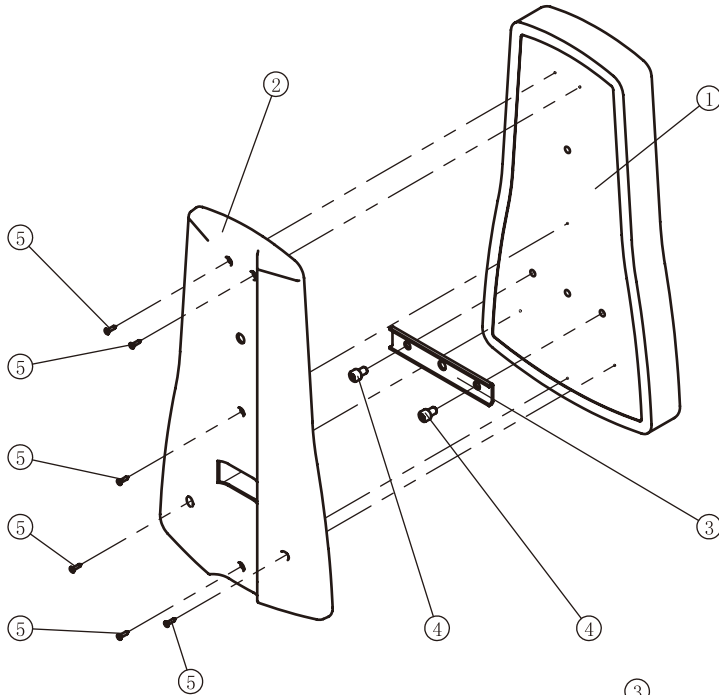

Head Pad ASSY

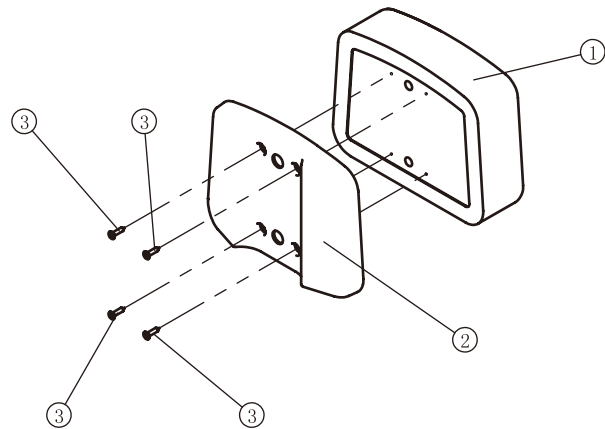

Item No.	Grade No.	Part No.	Description	QTY
1	34.1	IT95017100	Back Pad	1
2	34.2	IT95017300	Back Pad Cover	1
3	34.3	IT95017500	Back Pad Support Plate	1
4	34.4	GB70M10*15DS20	Socket Head Cap Screw M10*15	2
5	34.5	GB846ST4.2*19DHS	Cross Recessed Countersunk Head Tapping Screw ST4.2*19	6

Item No.	Grade No.	Part No.	Description	QTY
1	35.1	IT95017200	Head Pad	1
2	35.2	IT95017400	Head Pad Cover	1
2	35.3	GB846ST4.2*19DHS	Cross Recessed Countersunk Head Tapping Screw ST4.2*19	4

Exploded View and Parts List

Left Arm Frame ASSY

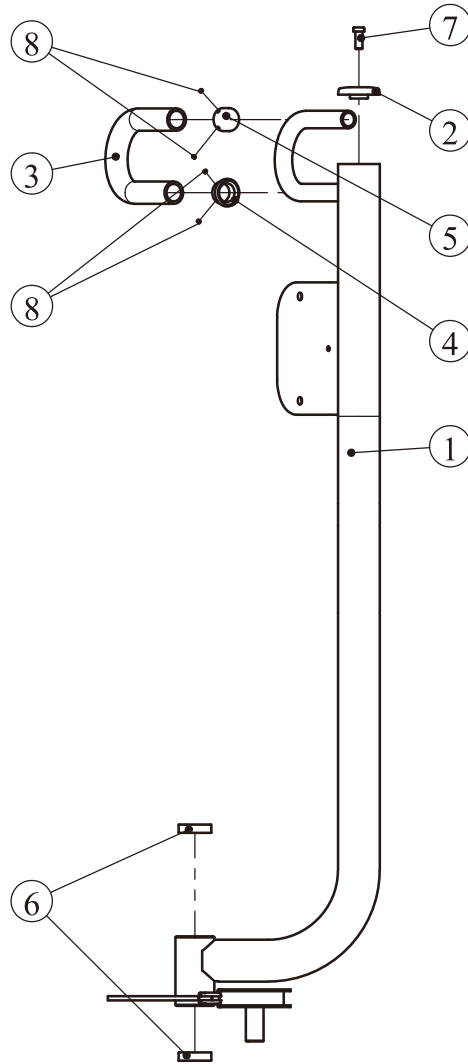

Item No.	Grade No.	Part No.	Description	QTY
1	14.1	IT95040400	Left Arm Frame	1
2	14.2	FE97211900	Cap $\Phi 60$	1
3	14.3	IT95041700	Grip	1
4	14.4	IT90102200	Aluminum Grip Ring	1
5	14.5	IT95022100	Aluminum Grip Cap	1
6	14.6	GB2766005-2RSC3NBK	Bearing	2
7	14.7	GB70BTM10*25DN18	Socket Head Cap Screw M10*25	1
8	14.8	YZGB7710-32*3.2N19	Socket Set Screw 10-32UNF*3.2	4

Exploded View and Parts List

Right Arm Frame ASSY

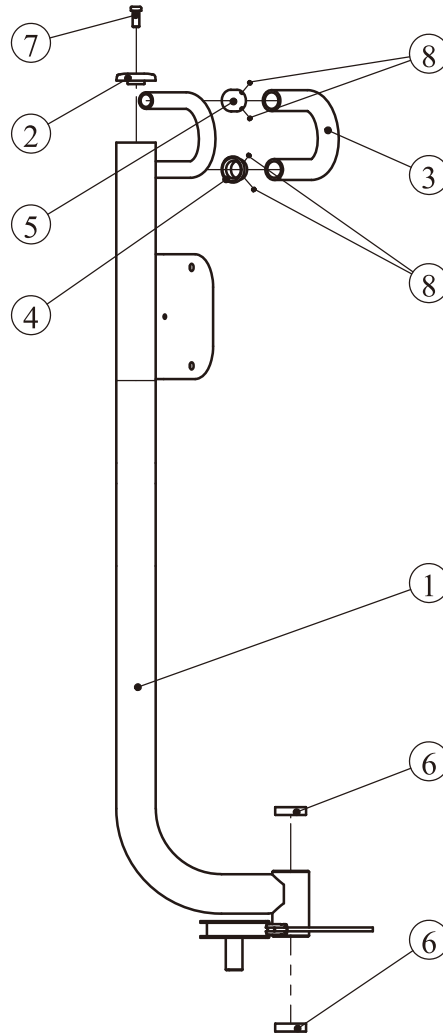

Item No.	Grade No.	Part No.	Description	QTY
1	13.1	IT95040300	Right Arm Frame	1
2	13.2	FE97211900	Cap $\Phi 60$	1
3	13.3	IT95041700	Grip	1
4	13.4	IT90102200	Aluminum Grip Ring	1
5	13.5	IT95022100	Aluminum Grip Cap	1
6	13.6	GB2766005-2RSC3NBK	Bearing	2
7	13.7	GB70BTM10*25DN18	Socket Head Cap Screw M10*25	1
8	13.8	YZGB7710-32*3.2N19	Socket Set Screw 10-32UNF*3.2	4

Exploded View and Parts List

Tension Cable ASSY

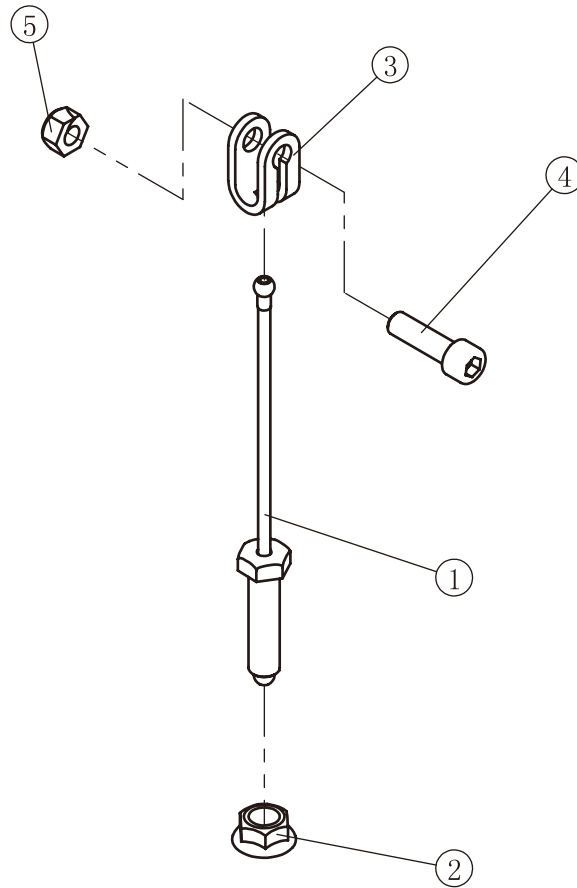

Item No.	Grade No.	Part No.	Description	QTY
1	22.1	IT95120801	Tension Cable	1
2	22.3	HF900-03A1002	Hex Flange Nut	1
3	22.4	BNH0562	Strap Bracket	1
4	22.5	GB70M10*35*15DN18	Socket Head Cap Screw M10*35	1
5	22.6	NM10DN2	Nylon Lock Nut M10	1

Measurement Guide

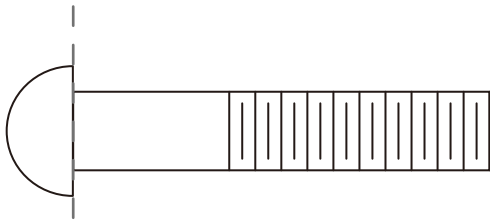

BHCS = Button Head Cap Screw

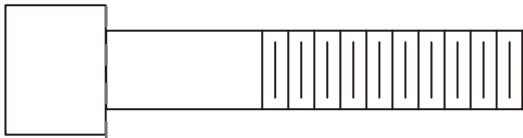

SHCS = Socket Head Cap Screw

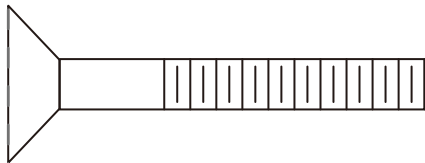

FHCS = Flat Head Cap Screw

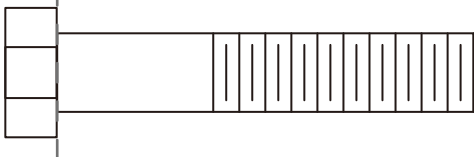

HHB = Hex Head Bolt

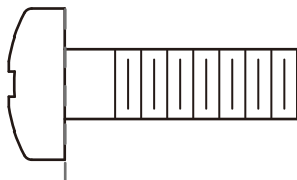

CRPHS = Cross Recessed Pan Head Screw

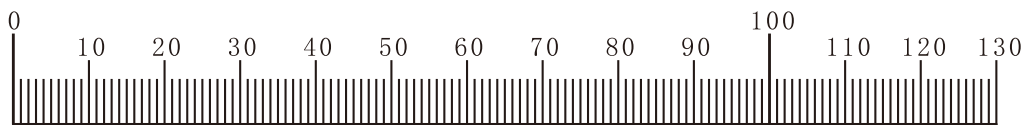

Millimeters



Inches

Diameter of bolt (mm/inch)	M6(1/4")	M8(5/16")	M10(3/8")	M12(1/2")	M16(5/8")
Tightening torque (N.m)	9~12	22~30	45~59	78~104	193~257
Operational methods for adult men	The strength of the wrist	The strength of the wrist and forearm	The strength of the entire arm	The strength of the arm and upper body	with all strength

Assembly Instructions

Assembly of the equipment takes professional installers about 2 hours. If this is the first time you have assembled this type of equipment, plan to spend more time. It is strongly recommended to assemble the equipment by professional installers. You may find it quicker, safer, easier to assemble this equipment with the help of a friend, as some of components may be large, heavy or awkward to handle alone. It is important that you assemble your product in a clean, clear, uncluttered area. This will enable you to move around the product while you are fitting components and reduce the possibility of injury during assembly.

NOTE

As with any assembled part, proper alignment and adjustment is critical. While tightening the fasteners, be sure to leave room for adjustments. Do not fully tighten the fasteners until instructed to do so. Be careful to assemble the components in the sequence presented in this guide.

Assembly

STEP 1

1. Attach two Adjustable Foot Plates (#31) to the Main Frame ASSY (#11).
2. Attach the Rear Bracket (#4) to the Top Rear Shroud (#9) using:
two M6*10 CRPHS (#55)

Note: Wrench Tighten Bolts.

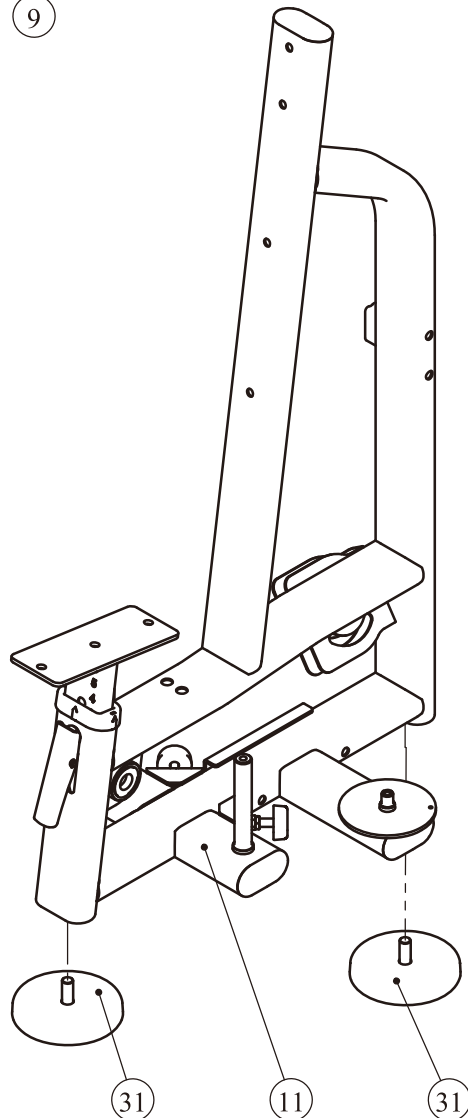
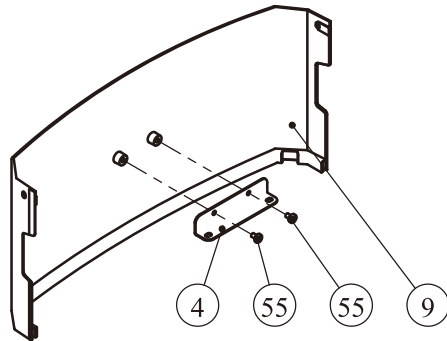

Assembly

STEP 2

Attach the Bottom Cross Brace (#12) and the Rear Connection Frame (#19) to Main Frame ASSY (#11) and the Weight Stack Frame ASSY (#1) using:

- four M12*135 SHCS (#66)
- two M12*30 SHCS (#65)
- two M10*80 SHCS (#64)
- four $\Phi 11*\Phi 20*2$ Flat Washer (#68)
- eight $\Phi 13*\Phi 24*2.5$ Flat Washer (#69)
- two M12 Nylon Lock Nut (#72)
- two M10 Nylon Lock Nut (#71)
- one Plastic Cover (#28)

Note: Wrench Tighten Bolts and Nylon Lock Nuts.

Adjust the Adjustable Foot Plates to make the machines stable.

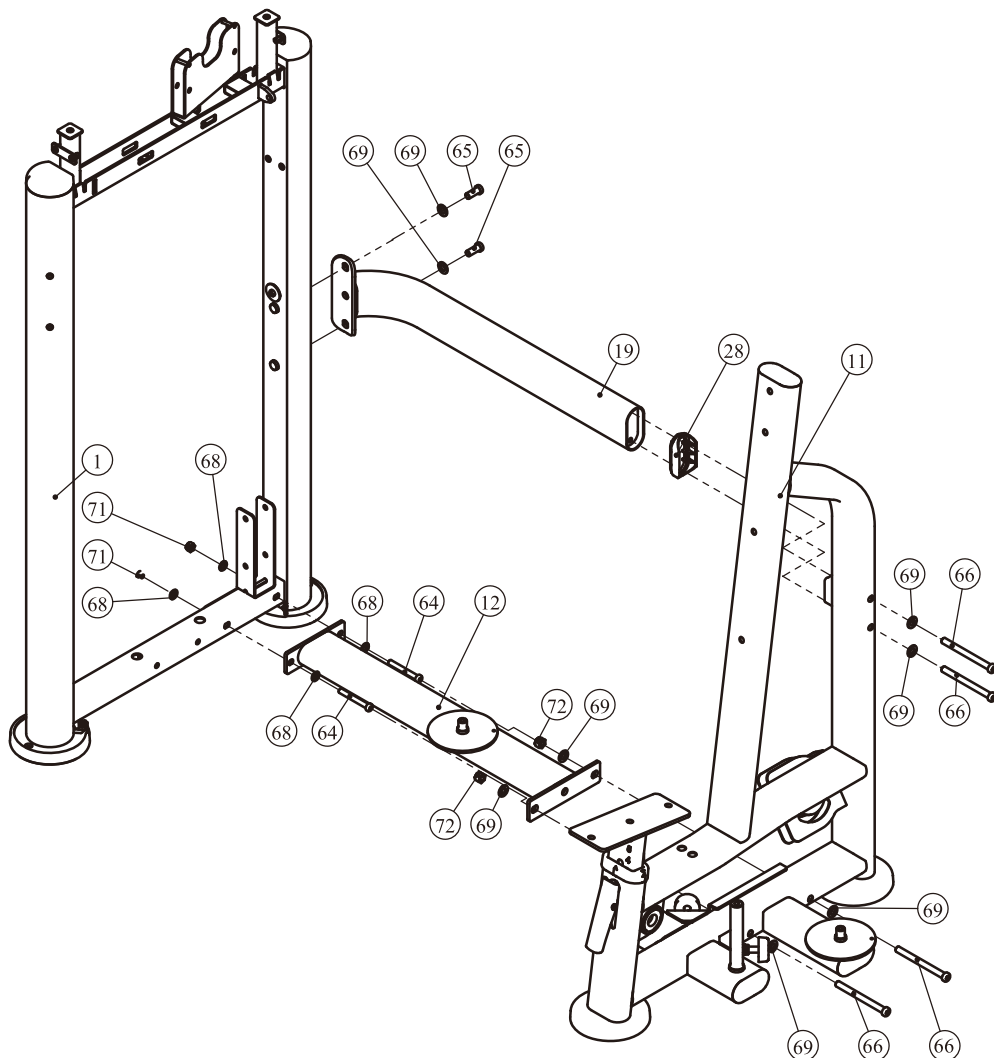

Assembly

STEP 3

1. Attach the Right Arm Frame ASSY (#13) and the Right Swing Frame ASSY (#15) and the Left-rotated Spring (#27) to the Main Frame ASSY (#11) using:
two $\Phi 31$ Bushing (#50)
2. Attach the Left Arm Frame ASSY (#14) and the Left Swing Frame ASSY (#16) and the Right-rotated Spring (#26) to the Main Frame ASSY (#11) using:
two $\Phi 31$ Bushing (#50)
3. Attach the Fixing Frame (#20) to the Main Frame ASSY (#11) using:
two Support Sleeve (#51)
two M10*25 SHCS (#60)
four $\Phi 11*\Phi 20*2$ Flat Washer (#68)
two M10*75 SHCS (#63)
two M10 Nylon Lock Nut (#71)

Note: Wrench Tighten Bolts and Nylon Lock Nuts.

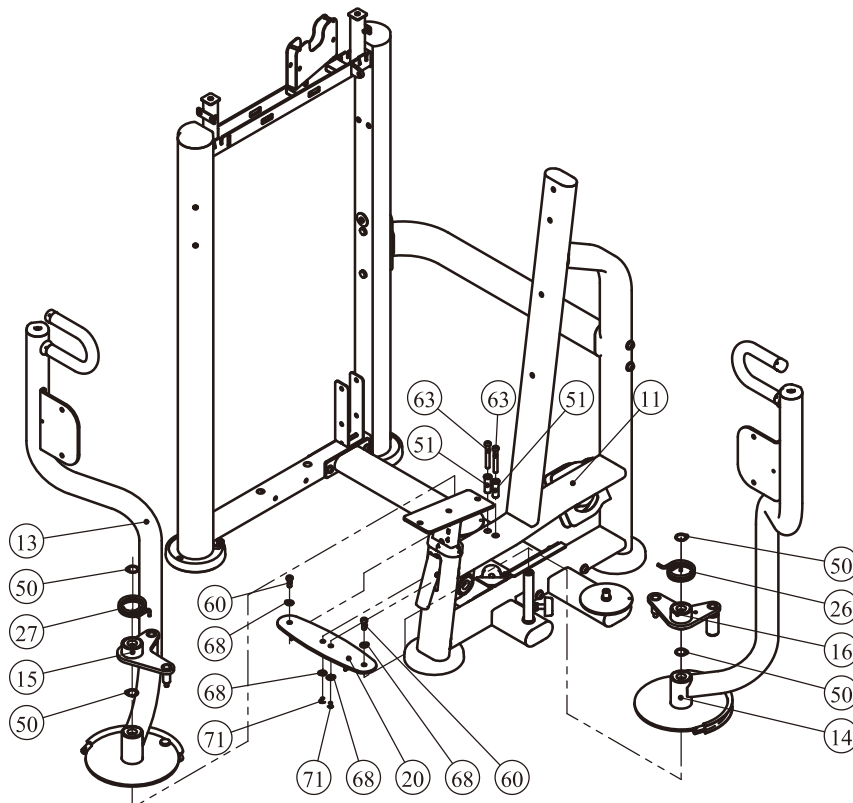
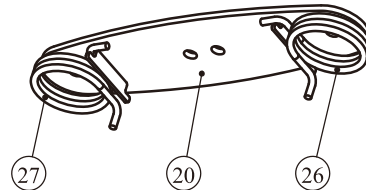

Assembly

STEP 4

- Attach the Top Bracket ASSY (#2) and two/one Bottom Bracket ASSY (#3) to the Weight Stack Frame ASSY (#1) using:

two M8*20 SHCS (#58)	two $\Phi 9 \times \Phi 16 \times 1.6$ Flat Washer (#67)
two M10*75 SHCS (#63)	four $\Phi 11 \times \Phi 20 \times 2$ Flat Washer (#68)
two M10 Nylon Lock Nut (#71)	
- Attach the Right Swing Frame ASSY (#15) and the Left Swing Frame ASSY (#16) to the Connection Frame (#18) using:

two $\Phi 11 \times \Phi 30 \times 2$ Flat Washer (#70)	two M10 Nylon Lock Nut (#71)
---	------------------------------
- Attach the Cable Connection Frame (#25) to the Connection Frame (#18) using:

two M12*60 SHCS (#111)	two M12 Nylon Lock Nut (#72)
four $\Phi 13 \times \Phi 24 \times 2.5$ Flat Washer (#69)	

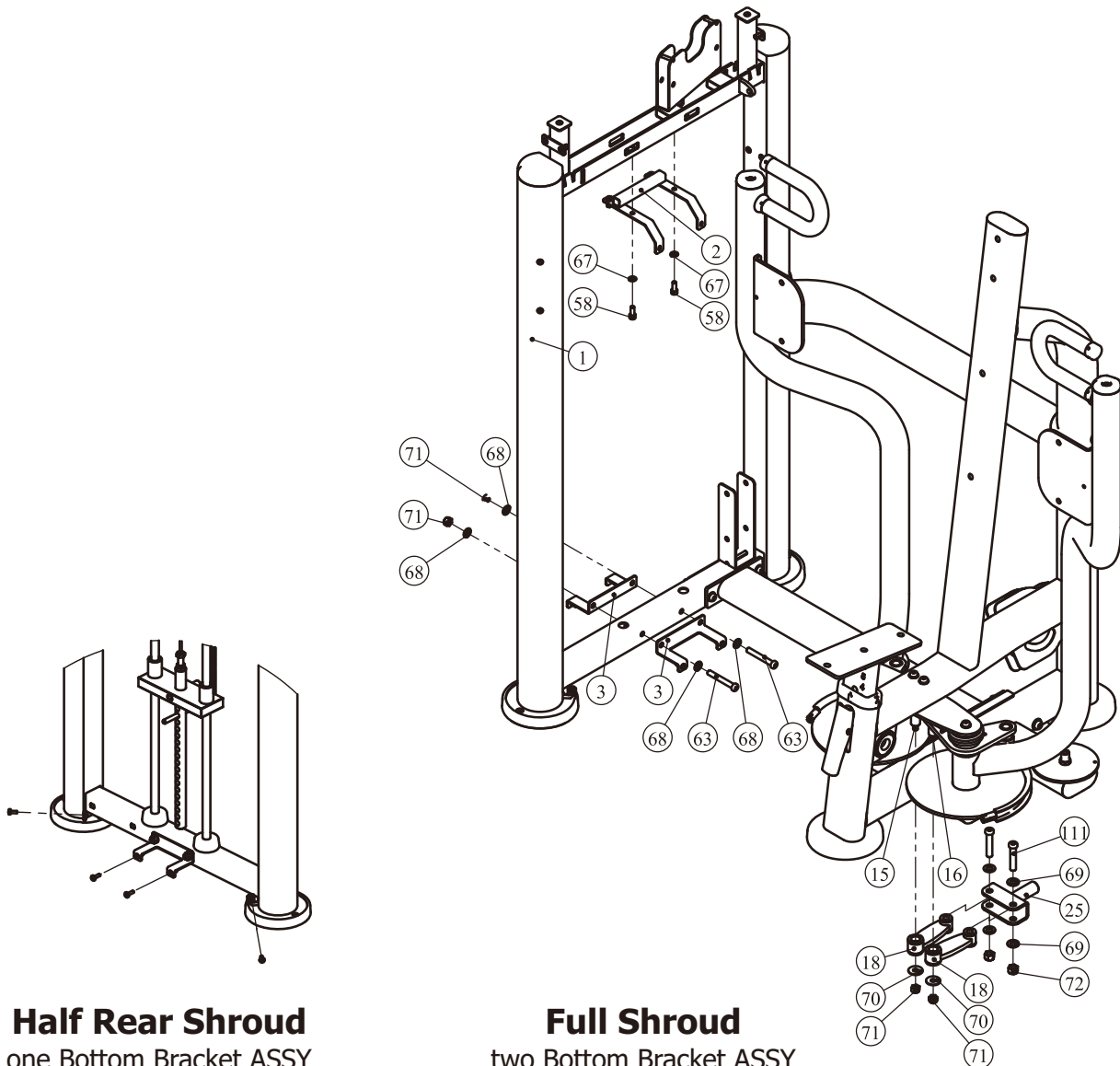

Half Rear Shroud
one Bottom Bracket ASSY

Full Shroud
two Bottom Bracket ASSY

Assembly

STEP 5

1. Attach three 4.5" Pulleys (#32) to the Weight Stack Frame ASSY (#1) using:
two M10*75 SHCS (#63) four $\Phi 11*\Phi 30*2$ Flat Washer (#68)
one Pulley Spacer (#49) two M10 Nylon Lock Nut (#71)
2. Attach the Startup Frame ASSY (#17) to the Main Frame ASSY (#11) using:
one $\Phi 62.5*5$ Circle Ring (#44) one $\Phi 60$ Cap (#45)
one M10*25 SHCS (#60)
3. Attach the Startup Cable ASSY (#23) to the Startup Frame ASSY (#17) and the Cable Connection Frame (#25).
4. Attach one 6" Pulley (#110) to the Main Frame ASSY (#11) using:
one M10*50 SHCS (#62) two $\Phi 11*\Phi 30*2$ Flat Washer (#68)
one M10 Nylon Lock Nut (#71)
5. Put one M4*15 SHCS (#57) into the Starting Frame ASSY (#17).

Note: Wrench tighten bolts and Nylon Lock Nuts.

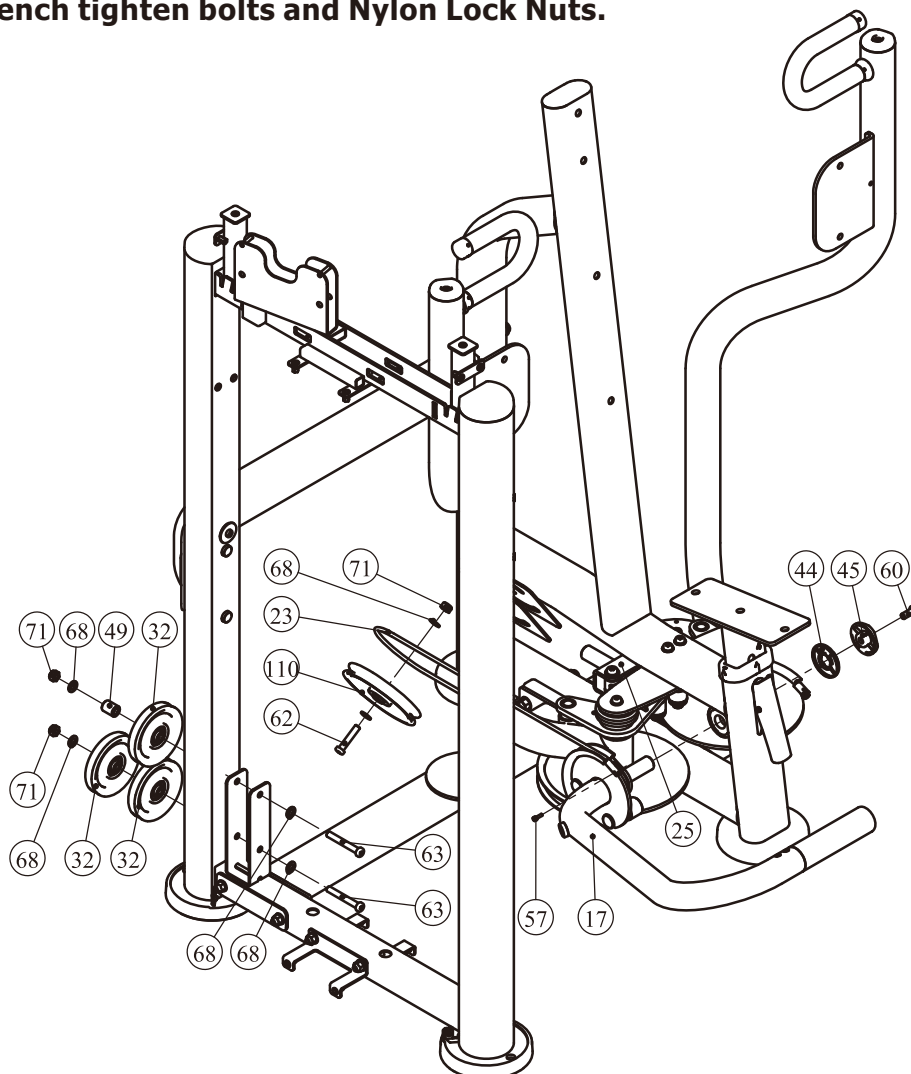

Assembly

STEP 6

Here is the assembly instruction for **160LBS Weights !**

1. Attach:

- two Guide Rod $\Phi 19 \times 1242$ (#6)
- two Weight Rubber Bumper (#42)
- fifteen Weight Plate 10LBS (#100)
- two weight stack space (#101)
- one Top Plate (#5)

to the Weight Stack Frame ASSY (#1) using:

- two Guide Rod Fixing Sleeve $\Phi 25 \times \Phi 19 \times 45$ (#43)
- two Spring (#46)

2. Attach the Selector Pin W/Coil (#41) to the Top Plate (#5).

Grade No.	Part No.	Description	QTY
100	FE97193100	10LBS Weight Plate	15
101	FEWS01ASSY	Weight Stack Space	2

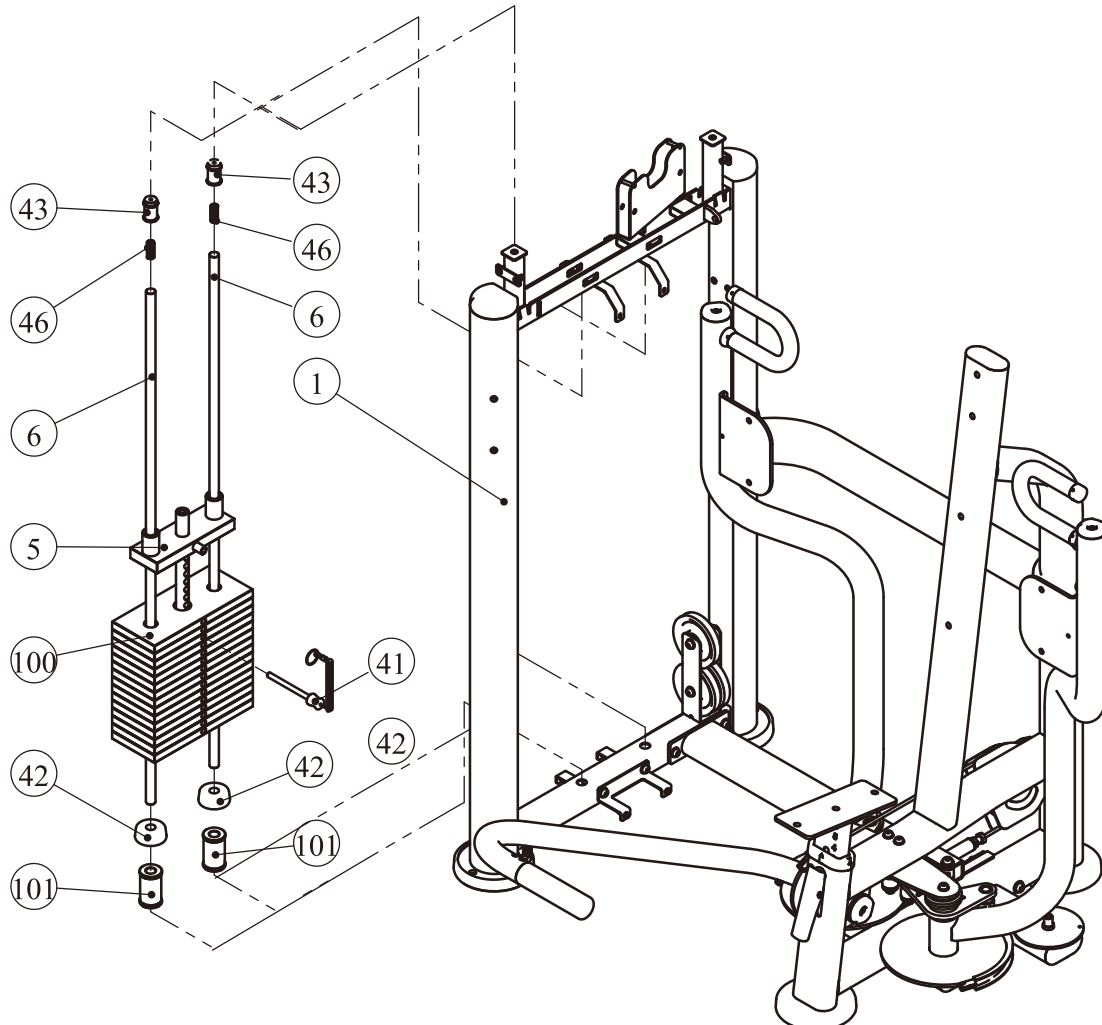

Assembly

STEP 6

Here is the assembly instruction for **200LBS Weights !**

1. Attach:

- two Guide Rod $\Phi 19 \times 1242$ (#6)
- two Weight Rubber Bumper (#42)
- nineteen Weight Plate 10LBS (#100)
- one Top Plate (#5)

to the Weight Stack Frame ASSY (#1) using:

- two Guide Rod Fixing Sleeve $\Phi 25 \times \Phi 19 \times 45$ (#43)
- two Spring (#46)

2. Attach the Selector Pin W/Coil (#41) to the Top Plate (#5).

Grade No.	Part No.	Description	QTY
100	FE97193100	10LBS Weight Plate	19

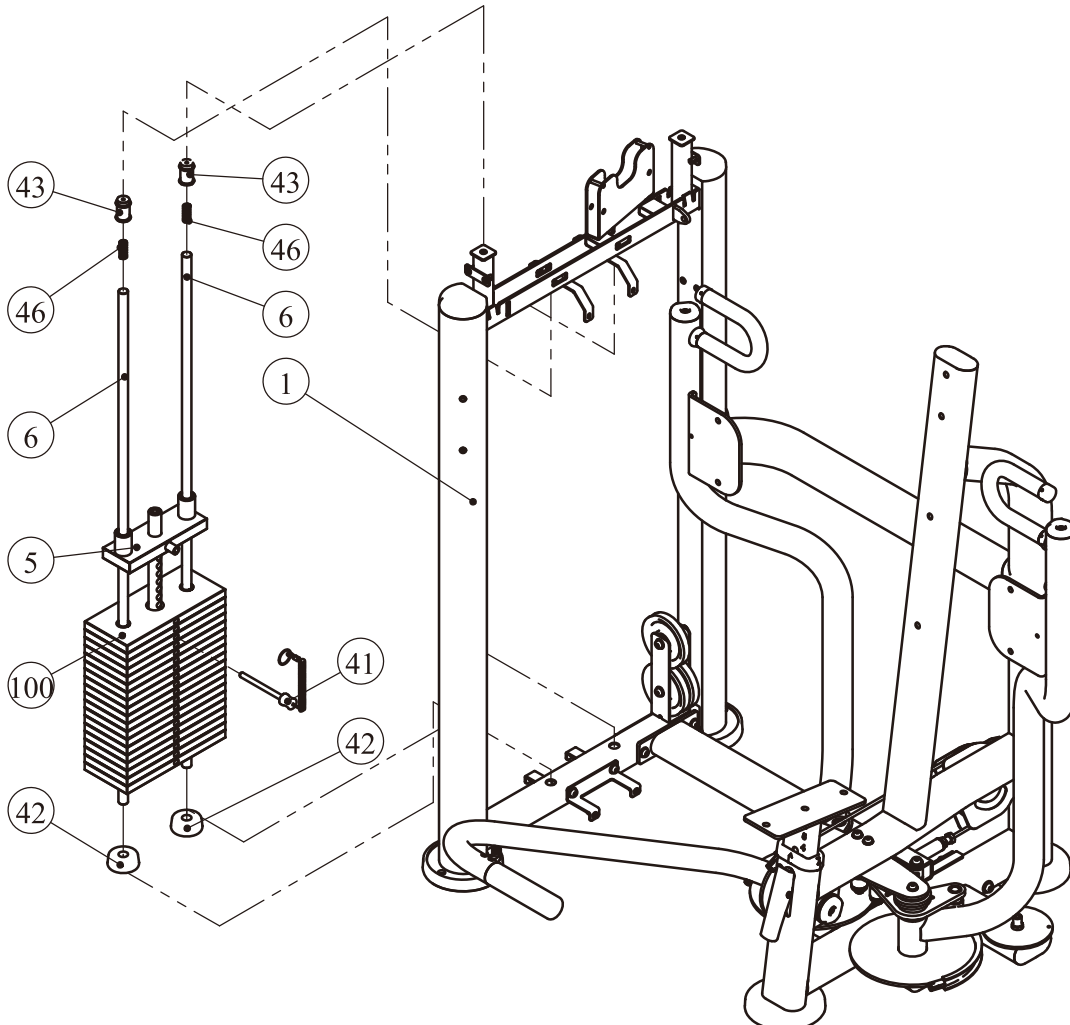

Assembly

STEP 6

Here is the assembly instruction for **235LBS Weights !**

1. Attach:

- two Guide Rod $\Phi 19 \times 1242$ (#6)
- two Weight Rubber Bumper (#42)
- fifteen Weight Plate 15LBS (#102)
- two weight stack space (#101)
- one Top Plate (#5)

to the Weight Stack Frame ASSY (#1) using:

- two Guide Rod Fixing Sleeve $\Phi 25 \times \Phi 19 \times 45$ (#43)
- two Spring (#46)

2. Attach the Selector Pin W/Coil (#41) to the Top Plate (#5).

Grade No.	Part No.	Description	QTY
102	FE97193200	15LBS Weight Plate	15
101	FEWS01ASSY	Weight Stack Space	2

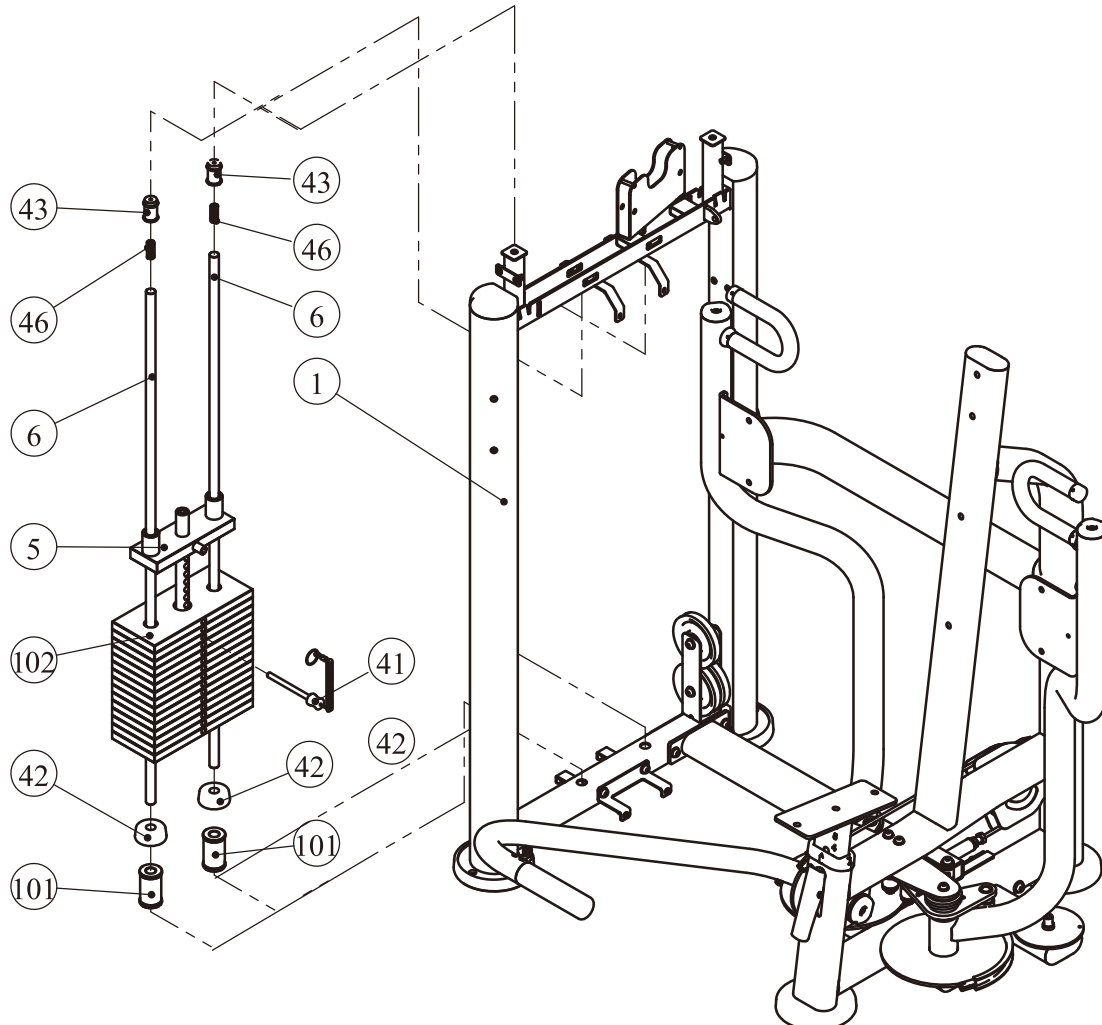

Assembly

STEP 6

Here is the assembly instruction for **295LBS Weights !**

1. Attach:

- two Guide Rod $\Phi 19 \times 1242$ (#6)
- two Weight Rubber Bumper (#42)
- nineteen Weight Plate 15LBS (#102)
- one Top Plate (#5)

to the Weight Stack Frame ASSY (#1) using:

- two Guide Rod Fixing Sleeve $\Phi 25 \times \Phi 19 \times 45$ (#43)
- two Spring (#46)

2. Attach the Selector Pin W/Coil (#41) to the Top Plate (#5).

Grade No.	Part No.	Description	QTY
102	FE97193200	15LBS Weight Plate	19

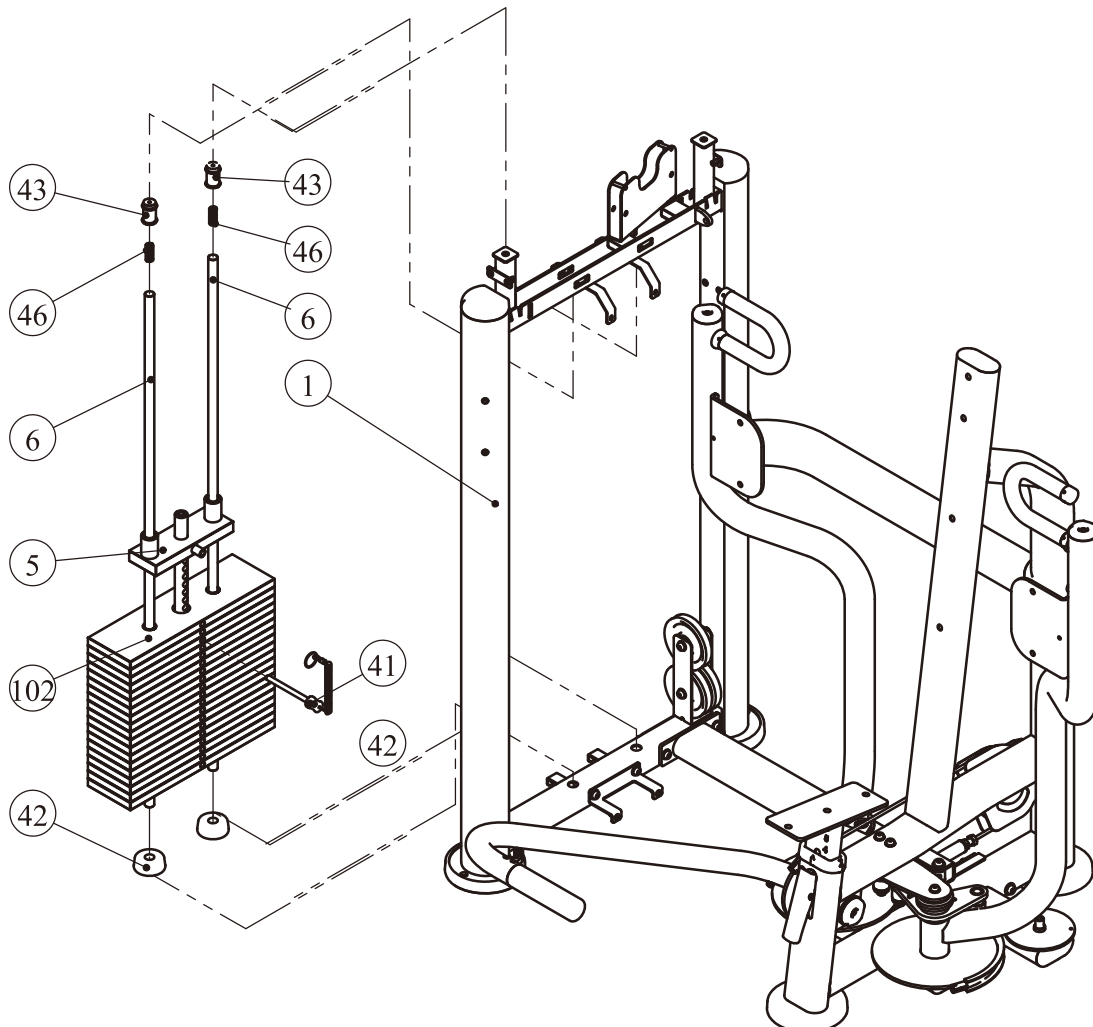

Assembly

All weight plate sticker paste schematic diagram

LBS 20	9
LBS 30	14
LBS 40	18
LBS 50	23
LBS 60	27
LBS 70	32
LBS 80	36
LBS 90	41
LBS 100	45
LBS 110	50
LBS 120	54
LBS 130	59
LBS 140	64
LBS 150	68
LBS 160	73
LBS 170	77
LBS 180	82
LBS 190	86
LBS 200	91
LBS 210	95
LBS 220	100
LBS 230	104

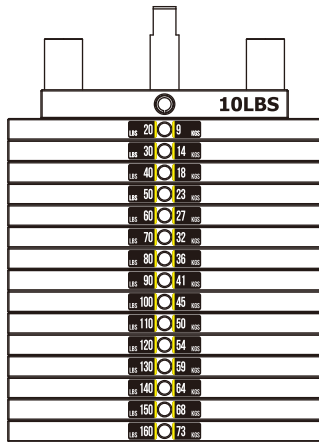

20-160LBS

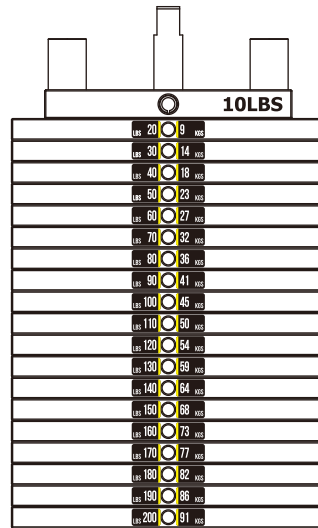

20-200LBS

LBS 25	11
LBS 40	18
LBS 55	25
LBS 70	32
LBS 85	38
LBS 100	45
LBS 115	52
LBS 130	59
LBS 145	66
LBS 160	72
LBS 175	79
LBS 190	86
LBS 205	93
LBS 220	100
LBS 235	107
LBS 250	113
LBS 265	120
LBS 280	127
LBS 295	134
LBS 310	141
LBS 325	147

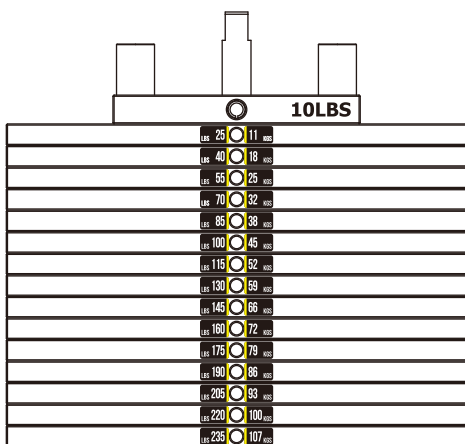

25-235LBS

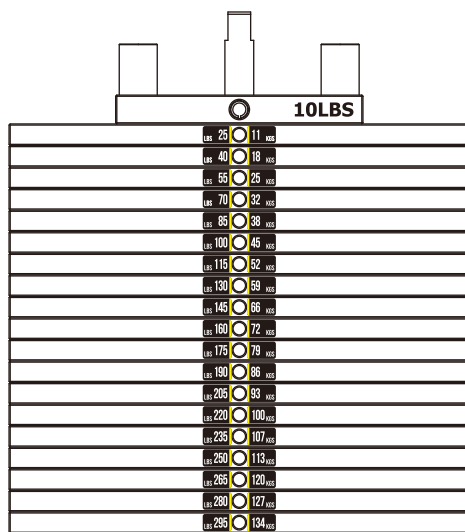

25-295LBS

Assembly

STEP 7

1. Attach two 4.5" Pulleys (#32) to the Weight Stack Frame ASSY (#1) using:
two M10*50 SHCS (#62) four $\Phi 11*\Phi 20*2$ Flat Washer (#68)
two M10 Nylon Lock Nut (#71)
2. Attach two 4.5" Pulleys (#32) to the Double Pulley Bracket (#21) using:
two M10*50 SHCS (#62) four $\Phi 11*\Phi 20*2$ Flat Washer (#68)
two M10 Nylon Lock Nut (#71)
3. Attach two Thin 4.5" Pulleys (#30) and one Polly Cover Plate (#112) to the Main Frame ASSY (#11) and the Bottom Cross Brace (#12), using:
two M10*25 SHCS (#60) two $\Phi 11*\Phi 20*2$ Flat Washer (#68)
two Pulley Spacer1 (#48) one Pulley Cover (#29)
one Threaded Column (#47) one Threaded Column (#113)
4. Take down one M10 Nylon Lock Nut and one M10*35 SHCS from the Tension Cable ASSY (#24), Attach the Tension Cable ASSY (#24) to the Top Plate (#5) and the Weight Stack Frame ASSY (#1) using:
one M10 Nylon Lock Nut (#Down off) one M10*35 SHCS (#Down off)
5. Attach the Cable ASSY (#22) to the Double Pulley Bracket (#21) and the Right Arm Frame ASSY (#13) and the Left Arm Frame ASSY (#14).
6. Attach two M4*15 SHCS (#57) to the Right Arm Frame ASSY (#13) and the Left Arm Frame ASSY (#14).

Note: Wrench tighten bolts and Nylon Lock Nuts.

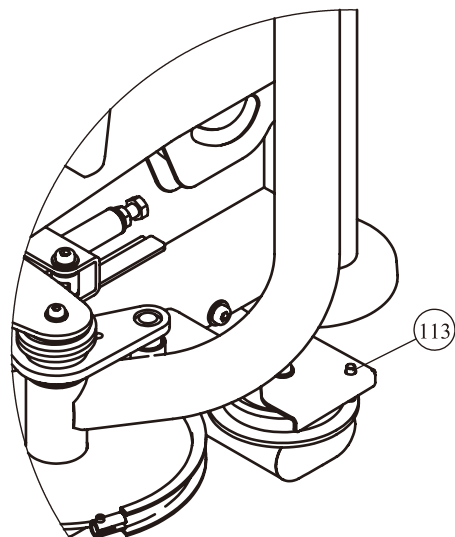
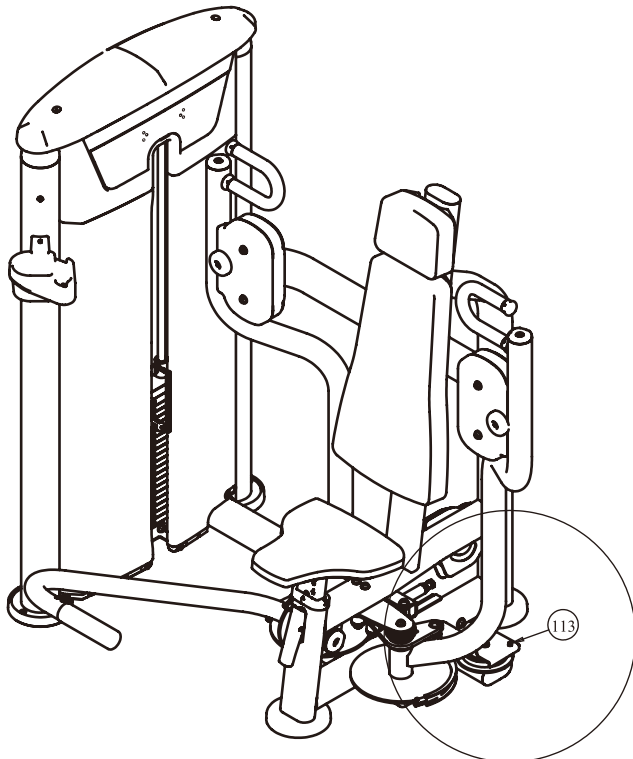

Assembly

STEP 7

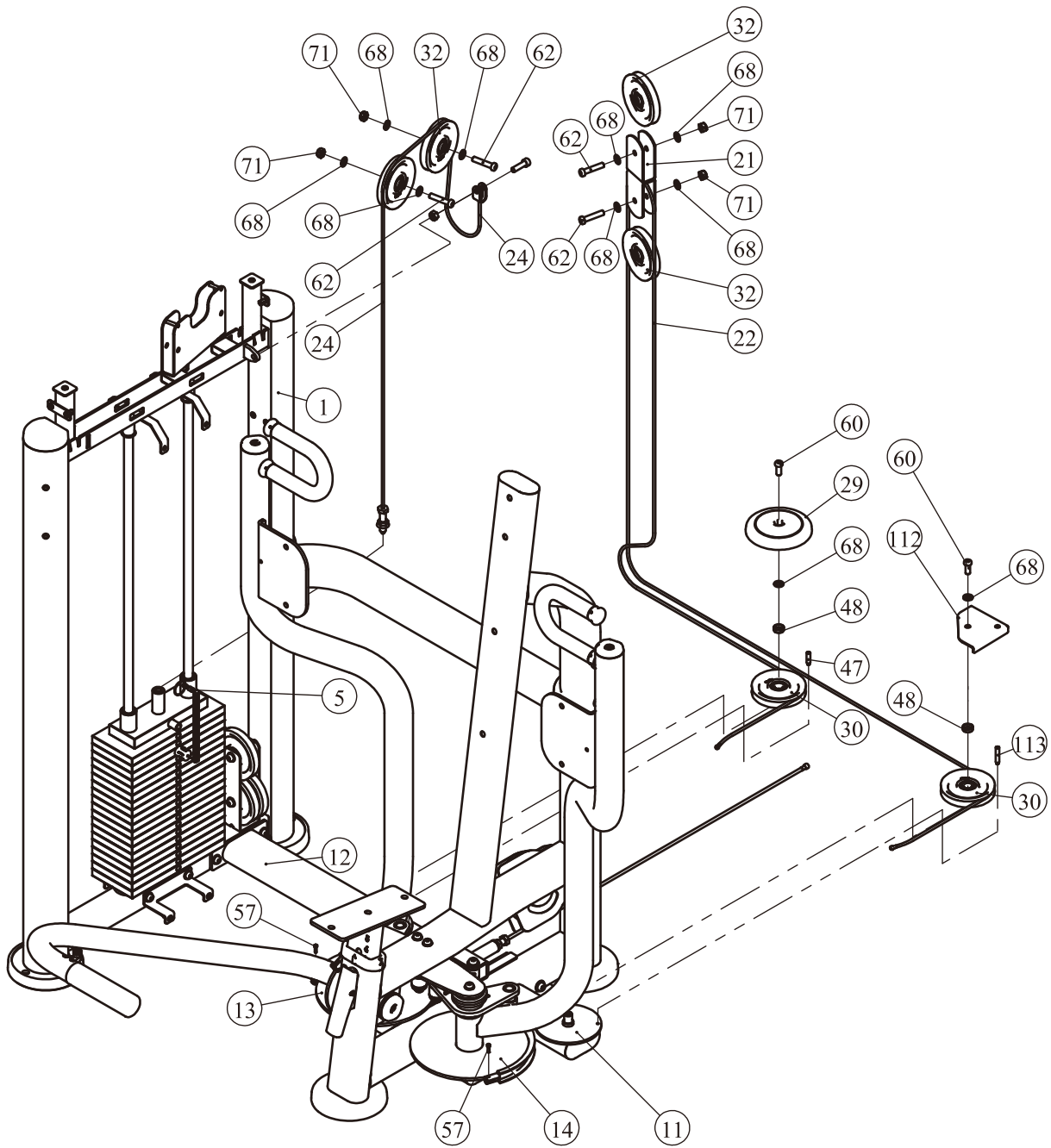

Assembly

Full Shroud

STEP 8

Tips: Pre-assemble the 8 bolts into the Weight Stack Frame ASSY and Bottom Bracket ASSY, not wrench tighten Bolts, Assemble the shroud with the bolts on. Then wrench tighten Bolts.

1. Attach the Front Shroud (#38) and the Right Front Shroud (#39) to the Weight Stack Frame ASSY (#1) and the Bottom Bracket ASSY (#3) using:

four M6*20 CRPHS (#54) two M6*16 CRPHS (#56)

2. Attach the Rear Shroud (#40) to the Weight Stack Frame ASSY (#1) and the Bottom Bracket ASSY (#3) using:

four M6*20 CRPHS (#54) two M6*16 CRPHS (#56)

3. Attach the Training Placard Cover (#8) to the Weight Stack Frame ASSY (#1) and the Top Bracket ASSY (#2) using:

two M6*20 CRPHS (#54) two M6*10 CRPHS (#55)

4. Attach the Top Rear Shroud (#9) to the Weight Stack Frame ASSY (#1) and the Top Bracket ASSY (#2) using:

four M6*20 CRPHS (#54)

5. Attach the Top Cover (#7) to the Weight Stack Frame ASSY (#1) using:

two M6*20 CRPHS (#54) two Spout Plug Φ 16.5*6.88 (#53)

6. Attach the Cup Holder (#10) to the Weight Stack Frame ASSY (#1) using:

two M6*20 CRPHS (#54)

Note: Wrench tighten bolts.

Half Rear Shroud

STEP 8

Tips: Pre-assemble the 4 bolt into the Weight Stack Frame ASSY and Bottom Bracket ASSY, not wrench tighten Bolts, Assemble the shroud with the bolt on. Then wrench tighten Bolts.

1. Attach the Half Rear Shroud (#200) to the Weight Stack Frame ASSY (#1) and the Bottom Bracket ASSY (#3) using:

four M6*20 CRPHS (#54) two M6*16 CRPHS (#56)

2. Attach the Training Placard Cover (#8) to the Weight Stack Frame ASSY (#1) and the Top Bracket ASSY (#2) using:

two M6*20 CRPHS (#54) two M6*10 CRPHS (#55)

3. Attach the Top Rear Shroud (#9) to the Weight Stack Frame ASSY (#1) and the Top Bracket ASSY (#2) using:

four M6*20 CRPHS (#54)

4. Attach the Top Cover (#7) to the Weight Stack Frame ASSY (#1) using:

two M6*20 CRPHS (#54) two Spout Plug Φ 16.5*6.88 (#53)

5. Attach the Cup Holder (#10) to the Weight Stack Frame ASSY (#1) using:

two M6*20 CRPHS (#54)

Note: Wrench tighten bolts.

Assembly

STEP 8

Full Shroud

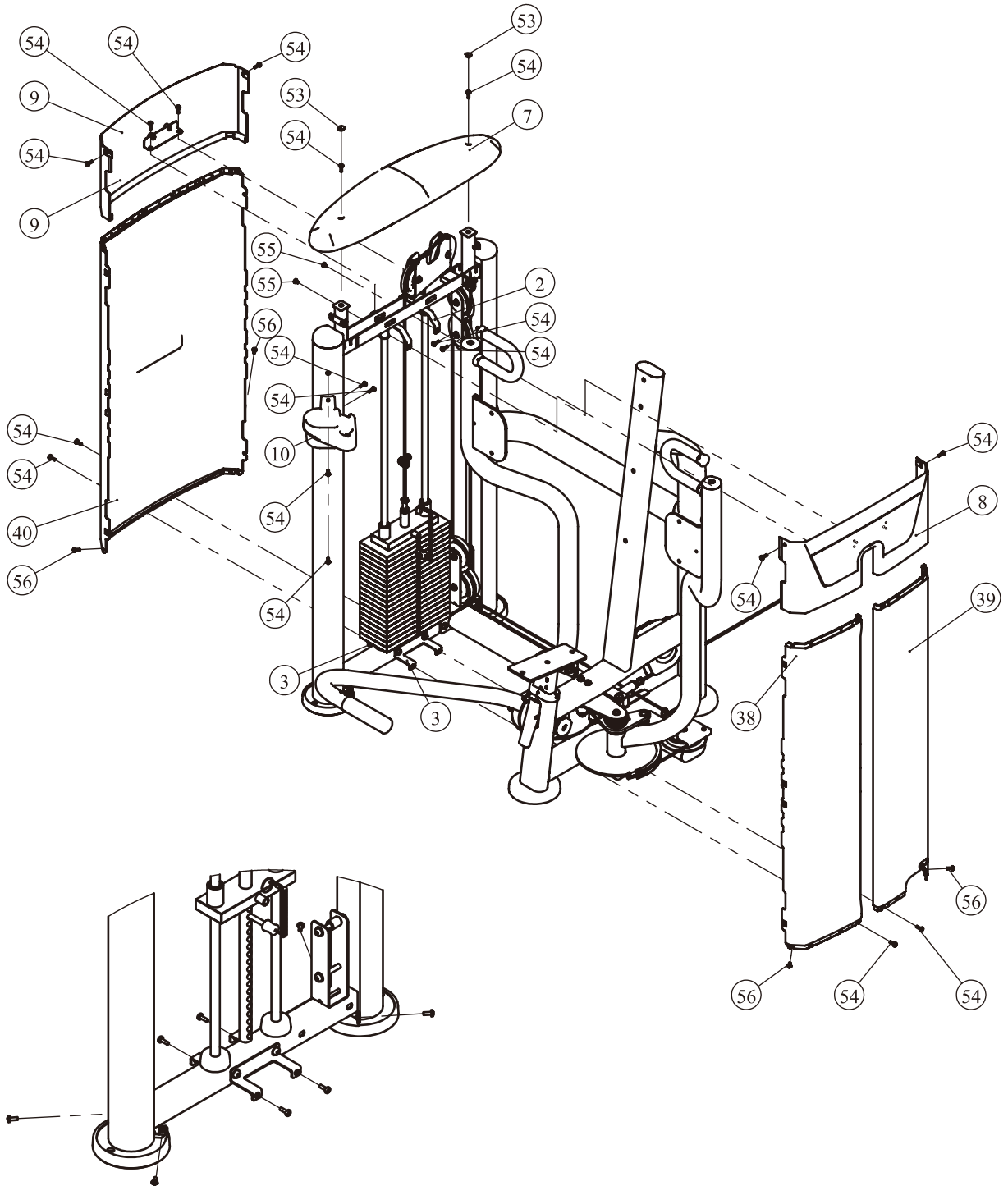

Assembly

STEP 8

Half Rear Shroud

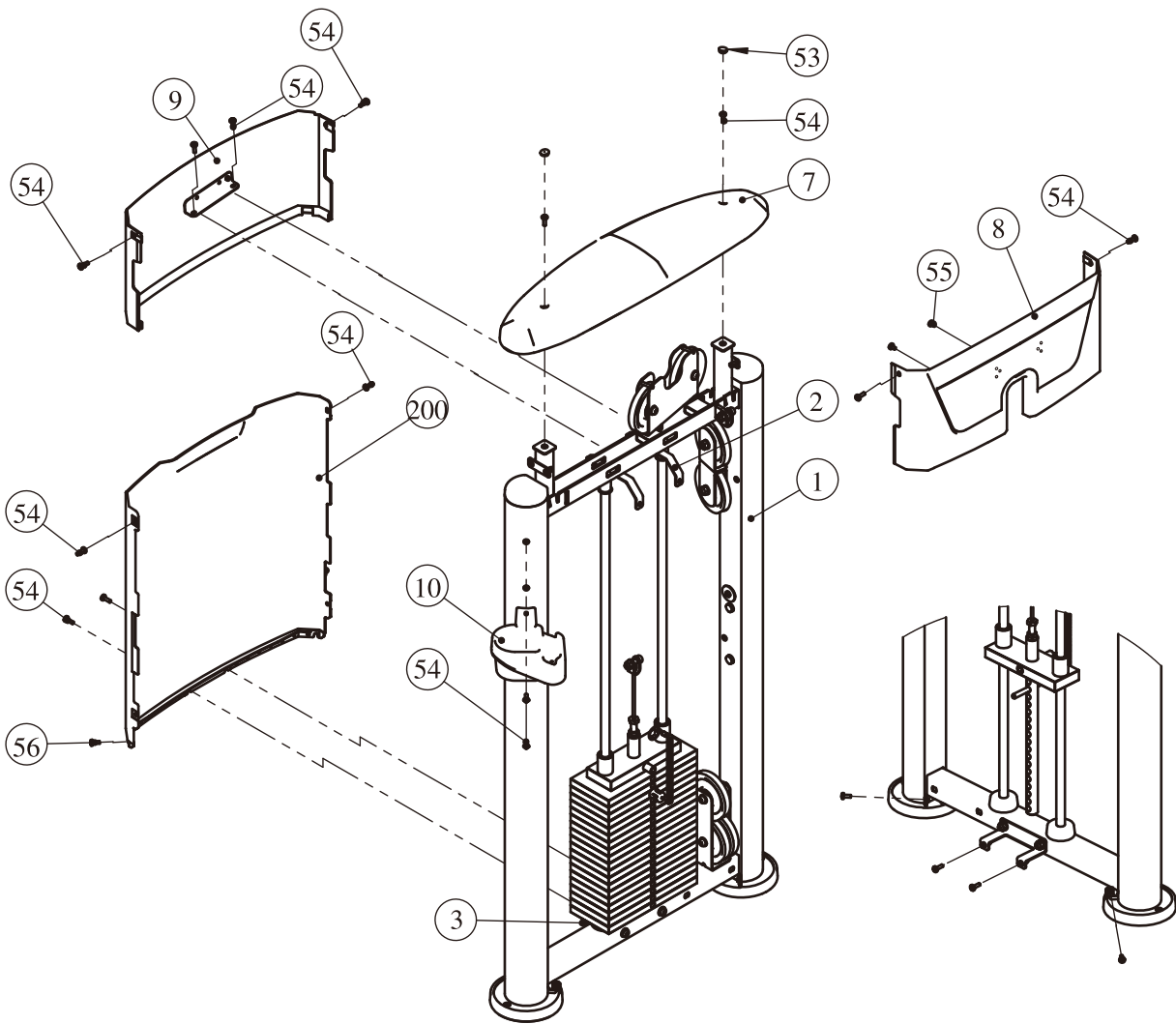

Assembly

STEP 9

1. Attach the Back Pad ASSY (#34) and the Head Pad ASSY (#35) to the Main Frame ASSY (#11) using:

four $\Phi 11 \times \Phi 20 \times 2$ Flat Washer (#68) four M10*80 SHCS (#64)

2. Attach the Seat Pad (#36) to the Main Frame ASSY (#11) using:

two M10*30 SHCS (#61) two $\Phi 11 \times \Phi 20 \times 2$ Flat Washer (#68)

3. Attach two Arm Pad (#33) and two Arm Pad Shroud (#37) to the Right Arm Frame ASSY (#13) and the Left Arm Frame ASSY (#14) using:

four M10*30 SCHCS (#61) four $\Phi 11 \times \Phi 20 \times 2$ Flat Washer (#68)

two M8*20 BHCS (#59) two $\Phi 63.5$ Rubber Bumper (#52)

Note: Wrench tighten bolts.

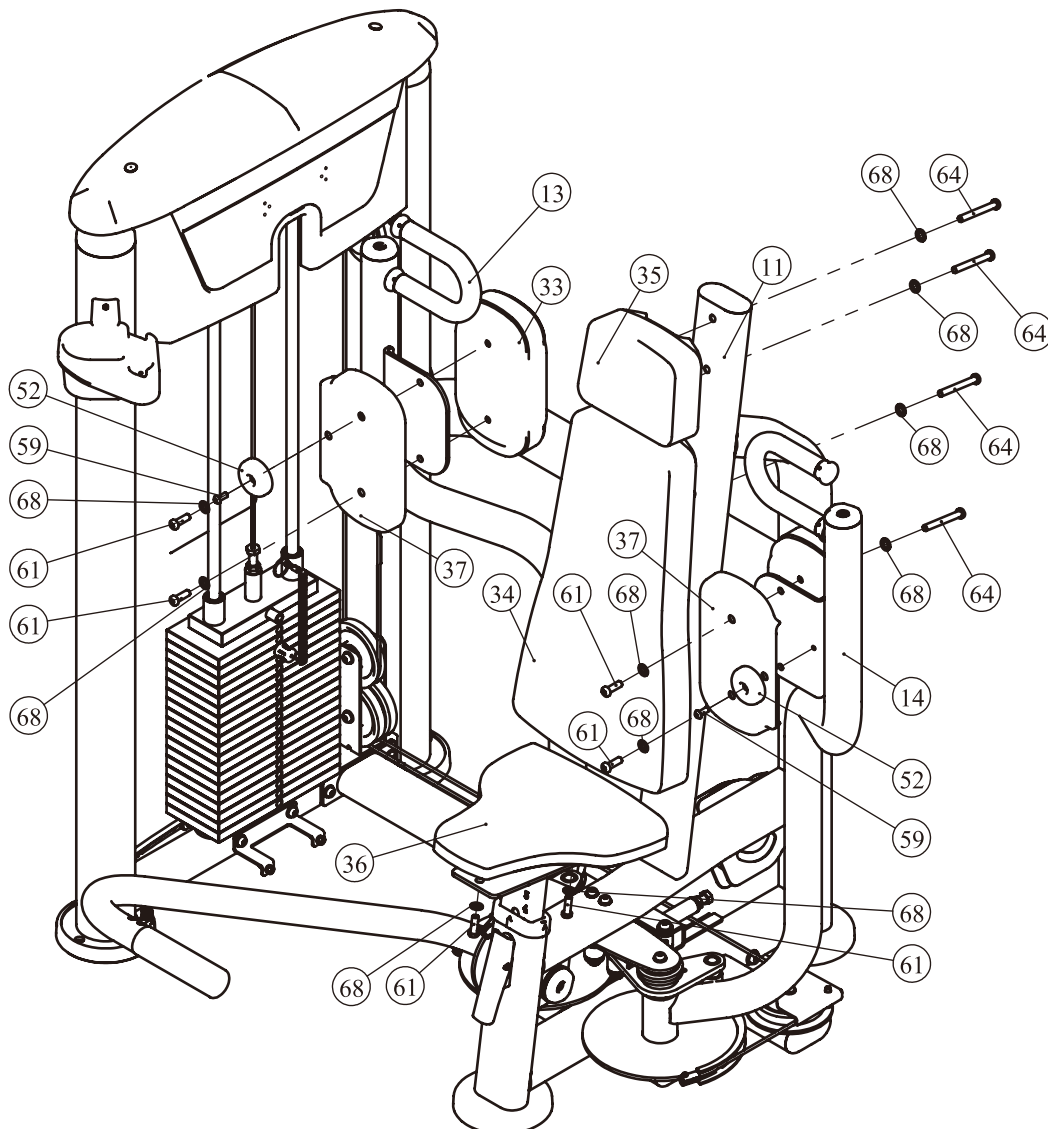

Adjust Instructions

The Seat Pad adjustment

1. Push the Adjustable Support and adjust the Seat Pad to the desired position.
2. Make sure the pin gets into the hole completely.

The use of Selector Pin W/Coil

1. Select an appropriate weight and put the Selector Pin W/Coil into the hole on it.
2. Make sure the Selector Pin W/Coil gets into the hole completely.

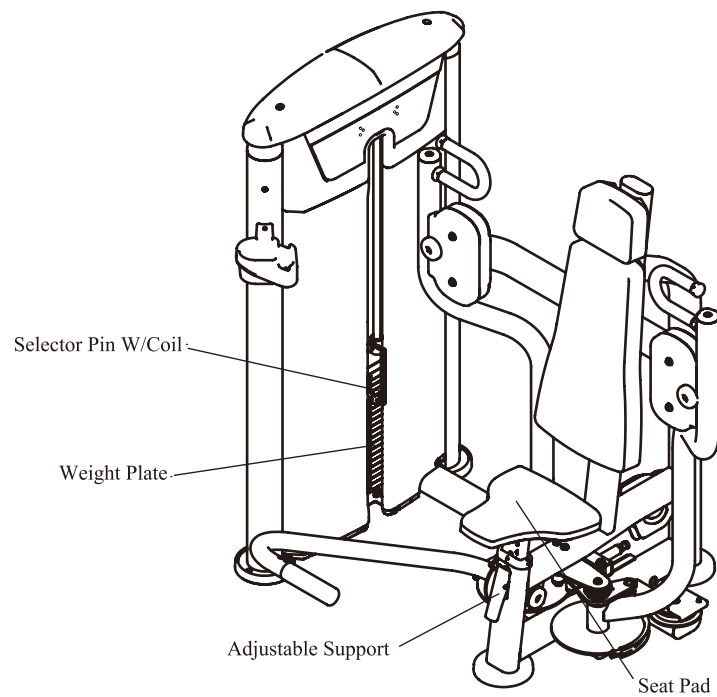

Exercise Instructions

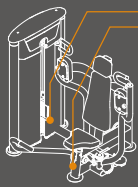
 1. Select the appropriate weight.
2. Adjust seat pad to the desired position.
3. Press start up perch by right foot, hold bar, release start up perch slowly, pullover to chest point.
4. Slowly return to the starting position.

PECTORAL

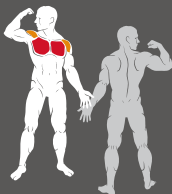
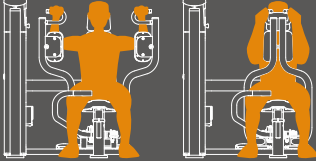
Start  Finish 

Maintenance Schedule

ROUTINE	COMMERCIAL MAINTENANCE	HOME MAINTENANCE	LATEST DATE ENTRY					
Inspect; Links, Pull Pins, Snap Locks, Swivels, Weight Stack Pins	DAILY	WEEKLY						
Clean; Upholstery	DAILY	WEEKLY						
Inspect; Cables or Belts and their tension	DAILY	WEEKLY						
Inspect; Accessory Bars, and Handles	WEEKLY	3 MONTHS						
Inspect; All Decals	WEEKLY	3 MONTHS						
Inspect; All Nuts and Bolts, Tighten if needed	WEEKLY	3 MONTHS						
Inspect; Anti-Skid Surface	WEEKLY	3 MONTHS						
Clean & Lubricate; Guide Rods with a Teflon (PTFE) based lubricant (Superlube)	MONTHLY	3 MONTHS						
Lubricate; Seat Sleeves, Turcite Bushings, Linear Bearing	MONTHLY	3 MONTHS						
Clean and Wax; All Glossy Finishes	6 MONTHS	YEARLY						
Repack with Grease; Linear Bearings	6 MONTHS	YEARLY						
Replace; Cables, Belts and Connecting Parts	YEARLY	3 YEARS						

Your equipment comes with a commercial maintenance decal. For personal, in home use, please follow the home maintenance schedule listed above.

General Maintenance Information

Links, Pull-Pins, Snap Hooks, Swivels, Weight Stack Pins:

- * Check all pieces for signs of visible wear or damage.
- * Check springs in snap hooks and pull-pins for proper tension and alignment.
- * If the spring sticks or has lost its rigidity, replace it immediately.

Upholstery:

- * To ensure prolonged upholstery life and proper hygiene, all upholstered pads should be wiped down with a damp cloth after every workout.
- * Periodically take the time to use a mild soap or an approved vinyl upholstery cleaner to deter the onset of cracking or drying. Avoid using any abrasive cleaners or cleaners not intended for use on vinyl.
- * Replace ripped or worn upholstery immediately.
- * Keep sharp or pointed objects clear of all upholstery.

Decals:

- * Inspect and familiarize yourself with any safety warnings or other user information posted on each decal.

Nuts and Bolts:

- * Inspect all nuts and bolts for any loosening and tighten if needed.
- * Go through a re-tightening sequence periodically to ensure that all hardware is tensioned proper.

Anti-Skid Surfaces:

- * These surfaces are designed to supply secure footing and need to be replaced if they appear worn or become slippery.

Belts and Cables:

- * We use only high quality belt, and mil-spec cables.
- * Visually inspect the belts and cables for fraying, cracking, peeling or discoloration.
- * While the machine is not in use, carefully run your fingers along the belt or cable to feel for thinning or bulging areas.
- * Replace belts and cables immediately at the first signs of damage or wear. Do not use equipment until belts or cables have been replaced.

Belt and Cable Tension:

- * Referring to the Owners Manual, when belts or cables are used check all bolt attachments to be sure they are properly attached.
- * Check slack in cables and re-adjust cable tension if needed.

Seat Sleeves, Guide Rods:

- * Wipe down adjusting tubes with a dust free rag before applying lubricant.
- * Lubricate seat sleeves and Guide Rods with a Silicon or Teflon based lubricant spray.

Linear Bearings:

- * Referring to the Owners Manual carefully disassemble the bearing from its housing and place a finger full of light grease (lithium, super lube, etc.) into the inside of the bearing. Using your finger, press the grease into the ball-bearings and their tracks. Repeat until the ball-bearing tracks are full of grease. Insert the shaft back into the bearing and wipe off excess grease.

PLEASE KEEP THIS FOR YOUR RECORDS

Weight Training Tips

Use this manual to guide you through the basic exercises you can perform on your equipment. To gain maximum results and avoid possible injury, consult a fitness professional to develop your complete exercise program.

Always consult your physician before starting any exercise program.

To be successful in your exercise program, it is important to develop an understanding of the basic principles of strength training. Now that you have your equipment, it is only natural that you want to get started immediately. First, determine a set of realistic goals and objectives for yourself. By deciding on an exercise plan that is right for you prior to starting, you will contribute significantly to your success.

Warm up properly before engaging in weight resistance training. Stretching, yoga, jogging, calisthenics or other cardiovascular exercise can help prepare your body for the heavier workload of lifting weights.

Learn how to perform the exercise correctly before using heavy weight. Correct form is important to avoid injury and to ensure that you work the proper muscle groups.

Know your limitations. If you are new to weight training or are embarking on an exercise regimen after a long layoff, start slowly and build foundational strength over a longer period of time.

Pay attention to your breathing. Exhale when you exert is a general rule of thumb. Never hold your breath.

