

# TAURUS®

## Owner's Manual



TF-IT9518

TORSO ROTATION IT95

TAURUS® is a registered brand of the company Fitshop GmbH.  
All rights reserved. Any use of this trademark without the explicit written permission of Fitshop is prohibited.

# Table Of Contents

## CAUTION!

Read all precautions and instructions in this manual before using this equipment.

Important Safety Instructions-----	3
Instructions-----	5
Exploded View and Parts List-----	6
Measurement Guide-----	19
Assembly Instructions-----	20
Assembly-----	21
Adjust Instructions-----	34
Exercise Instructions-----	35
Maintenance Schedule-----	36
General Maintenance Information-----	37
Weight Training Tips-----	38

# FITSHOP

Europe's No.1 for Home Fitness

Please assemble according to the actual **Weights** you buy !

# Important Safety Instructions

Before beginning any fitness program, you should obtain a complete physical examination from your physician. When using exercise equipment, basic precautions should always be taken, including the following:

1. Read all instructions before using the equipment.  
These instructions are written to ensure your safety and to protect the unit.
2. Use the equipment only for its intended purpose as described in this guide.  
Do not use accessory attachments that are not recommended by the manufacturer: such attachments might cause injuries.
3. The product should only be used on a level surface and is with 0.5 meters space around the product.  
Do not use the equipment outdoors.
4. Do not allow children on or near the equipment. And children are not allowed to use this equipment.  
Teenagers should use this equipment with adult supervision.
5. Do not overexert yourself or work to exhaustion.  
Do not attempt to lift more weight than you can control safely.  
If you feel any pain or abnormal symptoms, stop your workout immediately and consult your physician.
6. This equipment is not used as medical apparatus and instruments.
7. Never operate the unit when it has been dropped or damaged.  
Never drop or insert anything into any opening in the equipment.  
Always check the unit and its cables before each use. Make sure that all fasteners and cables are secure and in good working condition.  
Frayed or worn cables can be dangerous and may cause injury. Periodically check these cables for any indication of wear.  
Keep hands, limbs, loose clothing and long hair well out of the way of moving parts.
8. Be careful when getting on or off the equipment.
9. Wear proper exercise clothing and shoes for your workout, no loose clothing.

# Important Safety Instructions

## Personal Safety During Assembly

Read each step in the assembly instructions and follow the steps in sequence. Do not skip ahead. If you skip ahead, you may learn later that you have to disassemble components and that you may have damaged the equipment.

Assemble and operate the equipment on a solid, level surface. Locate the unit a few feet from walls or furniture to provide easy access. The equipment is designed for your enjoyment. By following these precautions and using common sense, you will have many safe and pleasurable hours of healthful exercise with the equipment.

## Training Area and Free Area

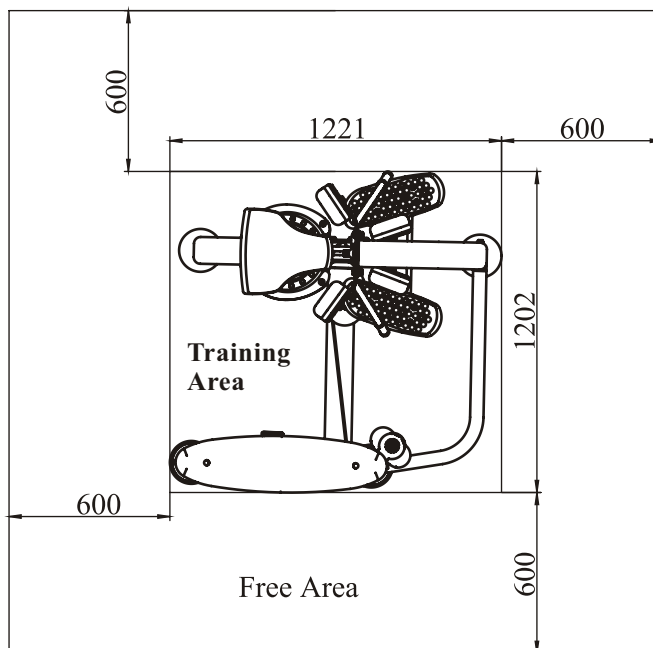

## Specifications

Class: S

Maximum Wt. Capacity: 134kg/ 295lbs

Maximum User Weight: 150kg/ 330lbs

Product Total Surface: 1221\*1202mm

Product Total Mass: 127.3 kg/ 281 lbs

# Instructions

Before beginning assembly please take the time to read instructions thoroughly. Please use the various lists in this manual to make sure that all parts have been included in your shipment. When ordering, use part number and description from the lists. Use only our replacement part when servicing. Failure to do so will void your warranty and could result in personal injury.

The equipment is designed to provide the smoothest, most effective exercise motion possible. After assembly, you should check all functions to ensure correct operation. If you experience problems, first recheck the assembly instructions to locate any possible errors made during assembly. If you are unable to correct the problem, call your authorized dealer. Be sure to have your serial number and this manual when calling. When all parts have been accounted for, continue on.

## Tools Required

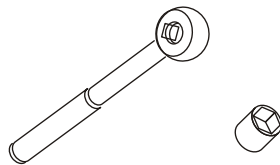

Ratchet Wrench and Socket

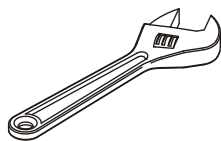

Adjustable Wrench

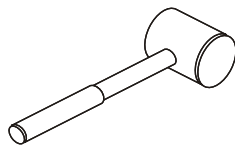

Rubber Mallet

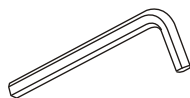

Hex Key Wrench Set

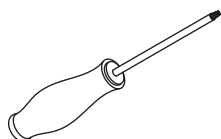

Phillips Screwdriver

# Exploded View and Parts List

## Overall

ItemNo.	Grade No.	Part No.	Description	QTY
1	1	IT951801ASSY	Weight Stack Frame ASSY	1
2	2	IT951802ASSY	Main Frame ASSY	1
3	3	IT951803ASSY	Bottom Cross Brace ASSY	1
4	4	IT951804ASSY	Handle Frame ASSY	1
5	5	IT951805ASSY	Left Foot Frame ASSY	1
6	6	IT951806ASSY	Wheel Frame ASSY	1
7	7	IT951807ASSY	Swivel Frame ASSY	1
8	8	IT951808ASSY	Connecting Frame ASSY	1
9	9	IT951810ASSY	Right Foot Frame ASSY	1
10	10	IT95170400	Rear Connection Frame	1
11	11	IT95171000	Seat Pad Support	1
12	12	IT950121ASSY	Top Bracket ASSY	1
13	13	IT950122ASSY	Bottom Bracket ASSY	2
14	14	SD1000B3000ASSY	Adjustable Foot Plate	2
15	15	RS16020800	Cable Connecting Frame	1
16	16	IT95183500	Main Shaft	1
17	17	IT95017600	Seat Pad	1
18	18	IT95012300	Rear Bracket	1
19	19	SG500110400V5	4.5" Pulley	3
20	21	IT95014400	Guide Rod $\phi$ 19*1242	2
21	22	IT95016000	Plastic Cover	2
22	23	IT95014200	Top Plate	1
23	24	FE97212000	Circle Ring $\phi$ 62.5*5	1
24	25	FE97211900	Cap $\phi$ 60	1
25	26	IT90012000V1	Selector Pin W/Coil	1
26	27	IT80023000	Weight Rubber Bumper	2
27	28	IT95016100	Guide Rod Fixing Sleeve $\phi$ 25* $\phi$ 19*45	2
28	30	FS600600	Short bushing	2
29	31	RS16026900	Short bushing	1
30	32	GB70M8*20N19	M8*20	2
31	33	GB5781M10*25N19	Hex Head Bolt M10*25	2
32	34	GB70BTM10*25DN18	Socket Head Cap Screw M10*25	3
33	35	GB70BTM10*50DN18	Socket Head Cap Screw M10*50	3
34	36	GB70BTM10*75DN18	Socket Head Cap Screw M10*75	2

# Exploded View and Parts List

## Overall

ItemNo.	Grade No.	Part No.	Description	QTY
35	37	GB70BTM10*80DN18	Socket Head Cap Screw M10*80	2
36	38	GB70BTM12*30DN18	Socket Head Cap Screw M12*30	4
37	39	GB70BTM12*80DN18	Socket Head Cap Screw M12*80	3
38	40	GB70BTM12*135DN18	Socket Head Cap Screw M12*135	4
39	41	GB70BTM10*30DN18	Socket Head Cap Screw M10*30	8
40	42	GB818M6*10DHS2	Cross Recessed Pan Head Screw M6*10	4
41	43	GB818M6*16DHS2	Cross Recessed Pan Head Screw M6*16	4
42	44	GB818M6*20DHS2	Cross Recessed Pan Head Screw M6*20	18
43	45	GB958DN2	Flat Washer $\phi$ 9* $\phi$ 16*1.6	2
44	46	GB9510DN2	Flat Washer $\phi$ 11* $\phi$ 20*2	24
45	47	GB9512DN2	Flat Washer $\phi$ 13* $\phi$ 24*2.5	16
46	48	TLE-2824600	Cap	1
47	49	HFOPT900-04A0602	Spring	2
48	50	NM10DN2	Nylon Lock Nut M10	7
49	51	NM12DN2	Nylon Lock Nut M12	5
50	52	NM8DN2	Nylon Lock Nut M8	1
51	53	IT801210300P11C	Cup Holder	1
52	54	IT95015200	Training Placard Cover	1
53	55	IT95015500	Top Rear Shroud	1
54	56	IT95015300	Front Shroud	1
55	57	IT95055400	Left Front Shroud	1
56	58	IT95015600	Rear Shroud	1
57	59	IT95015100	Top Cover	1
58	60	IT95186000	Cable ASSY	1
59	61	IT95184000	Arm Pad	4
60	62	IT93149300	Weight Stack Space 300	2
61	63	IT95016500	Spout Plug $\phi$ 16.5*6.88	2
62	64	NM16DN2	Nylon Lock Nut M16	1
63	66	NBS0.188DHS	Hex Key S=3/16"	1
64	67	NBS6DHS	Hex Key S=6	1
65	68	NBS8DHS	Hex Key S=8	1
66	69	LW200BS	Wrench $\phi$ 6*117	1
67	70	YHY	Lube	1
68	74	HFOPT900-04A1400	Aluminium Sheath $\phi$ 14.5*27	1
69	80	NBS10DHS	Hex Key S=10	1

# Exploded View and Parts List

## Overall

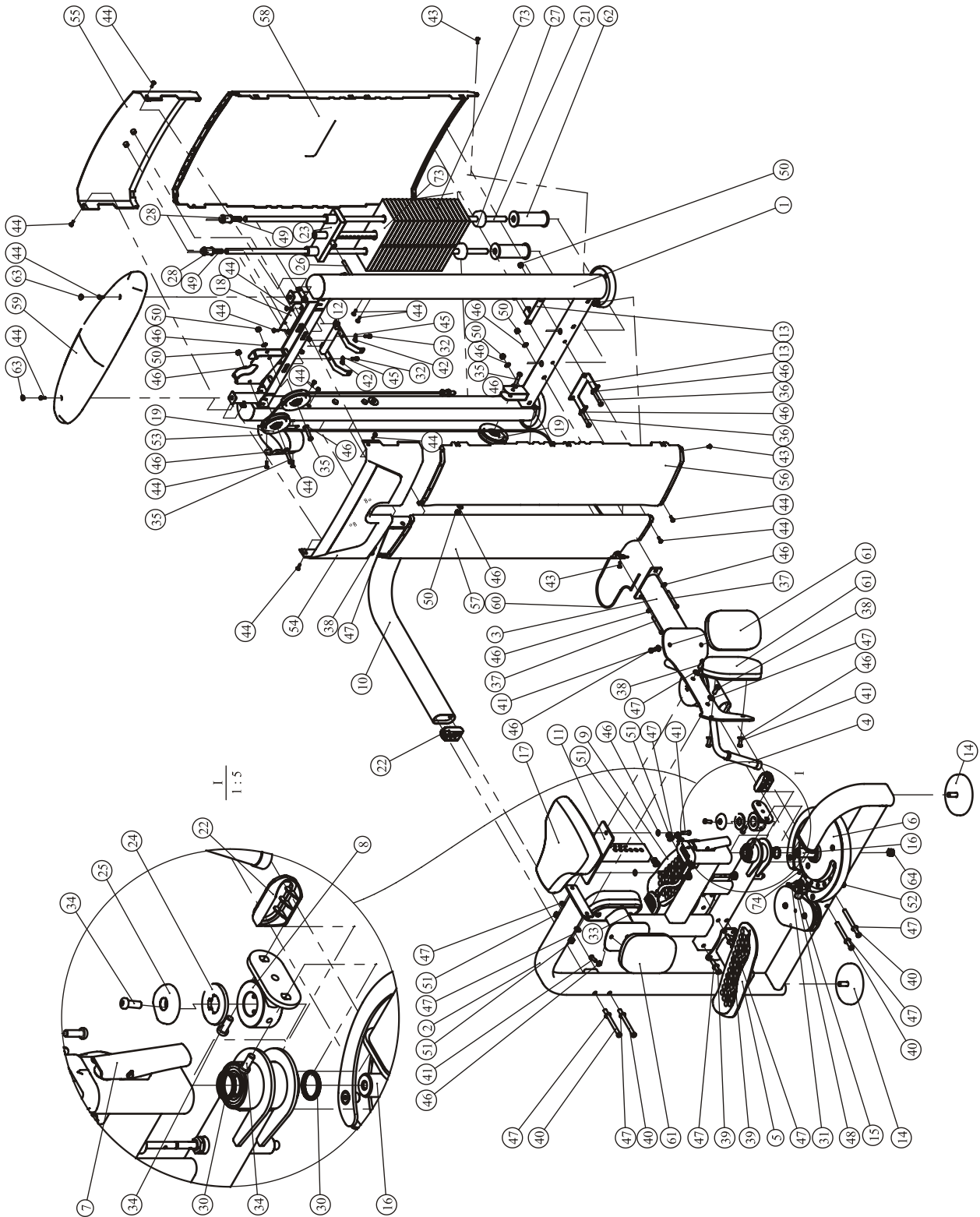



# Exploded View and Parts List

## Weight Stack Frame ASSY

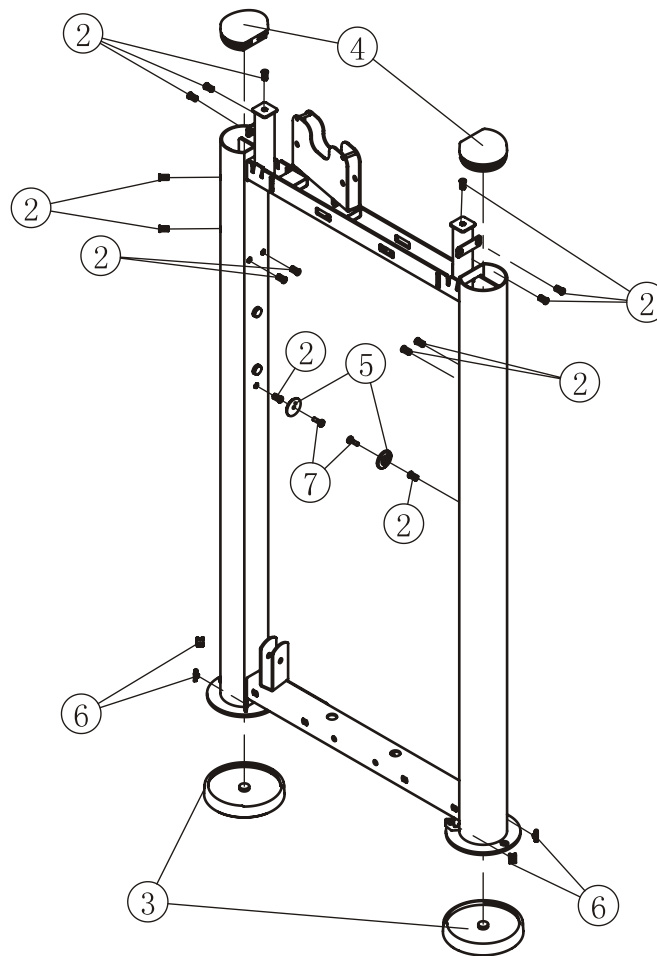

ItemNo.	Grade No.	Part No.	Description	QTY
1	1.1	IT95180100	Weight Stack Frame	1
2	1.2	GB17880.5M6*16.5DS17	Rivet Nut M6	14
3	1.3	IT95015700	Foot Plate	2
4	1.4	IT95015800	Plug $\phi$ 95*81.1	2
5	1.5	IT95015900	Plastic Block	2
6	1.6	AC32705800	U-nut M6	4
7	1.7	GB818M6*20DHS2	Cross Recessed Pan Head Screw M6*20	2

# Exploded View and Parts List

## Main Frame ASSY

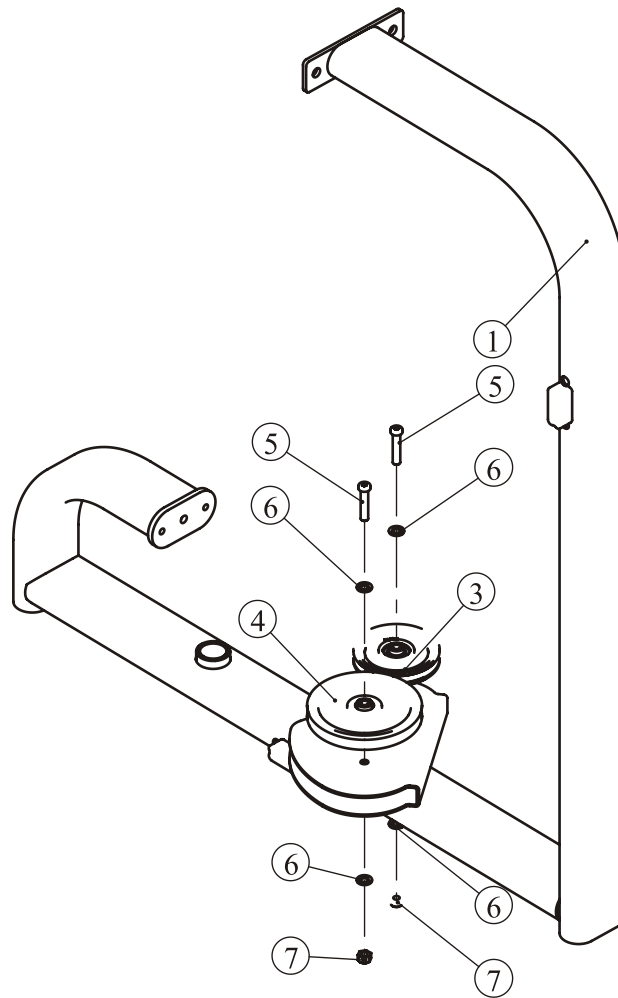

ItemNo.	Grade No.	Part No.	Description	QTY
1	2.1	IT95180200	Main Frame	1
2	2.3	SG500110400V5	Thin 4.5" Pulley	1
3	2.4	L1-3800	Thin 6" Pulley	1
4	2.5	GB70BTM10*50DN18	Socket Head Cap Screw M10*50	2
5	2.6	GB9510DN2	Flat Washer $\phi 11 * \phi 20 * 2$	4
6	2.7	NM10DN2	Nylon Lock Nut M10	2

# Exploded View and Parts List

## Bottom Cross Brace ASSY

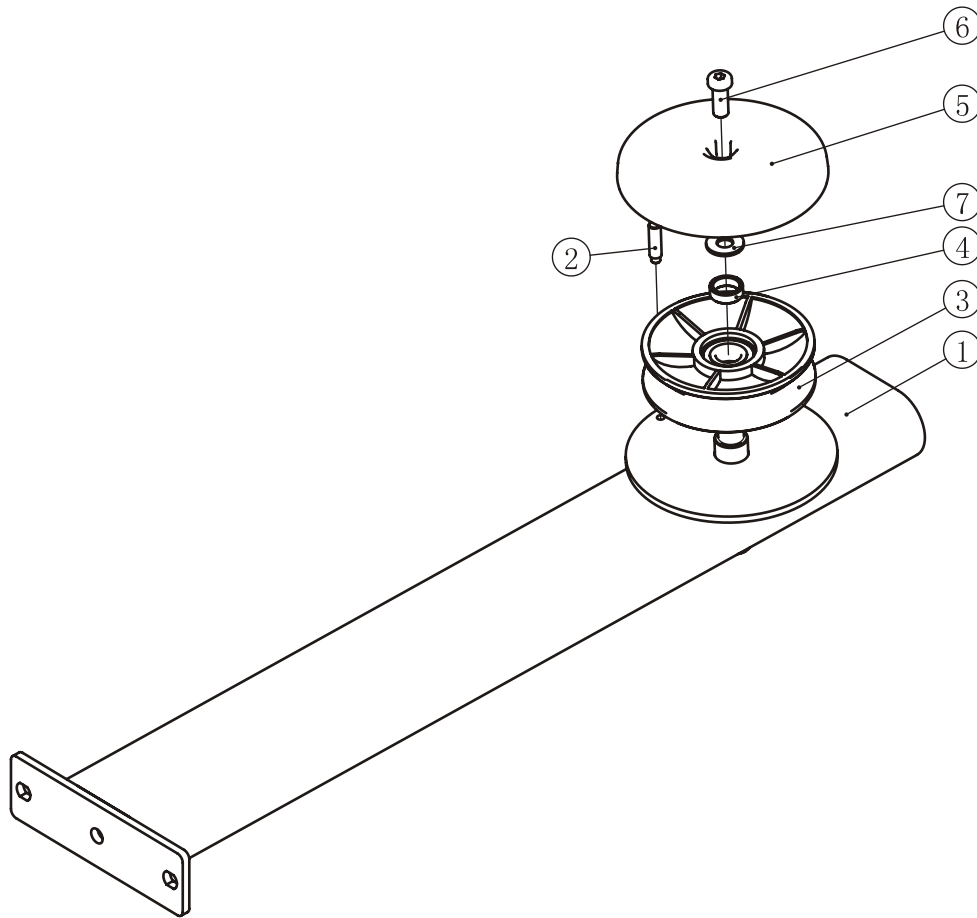

ItemNo.	Grade No.	Part No.	Description	QTY
1	3.1	IT95180300	Bottom Cross Brace	1
2	3.2	FE97122300	Threaded column	1
3	3.3	FE97123600	V Pulleys	1
4	3.4	FE97122100	Pulley Spacer 1	1
5	3.5	IT95016400	Pulley Cover	1
6	3.6	GB70BTM10*25DN18	Socket Head Cap Screw M10*25	1
7	3.7	DQ10N19B	Flat Washer $\phi 11 * \phi 25 * 2$	1

# Exploded View and Parts List

## Handle Frame ASSY

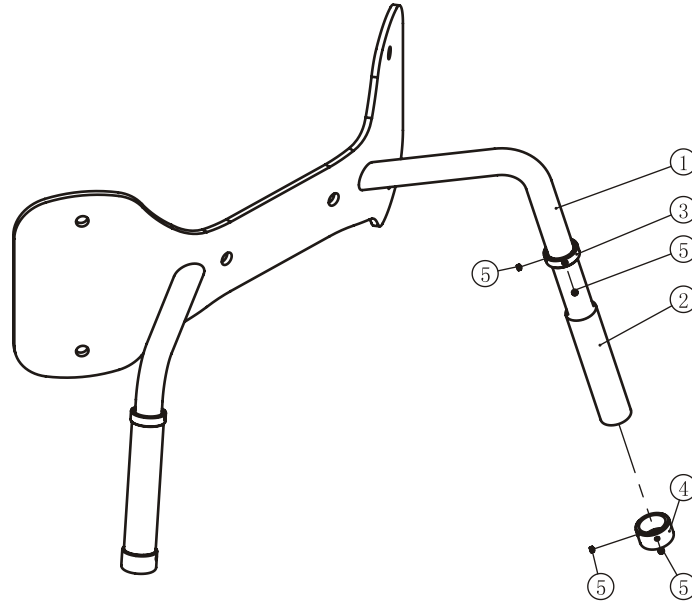

ItemNo.	Grade No.	Part No.	Description	QTY
1	4.1	IT95180400	Handle Frame	1
2	4.2	026-01PL0206-12	Grip	2
3	4.3	V39500	Aluminum Grip Ring	2
4	4.4	V39600	Aluminum Grip Cap	2
5	4.5	YZGB7710-32*3.2N19	Socket Set Screw 10-32UNF*3.2	8

## Connecting Frame ASSY

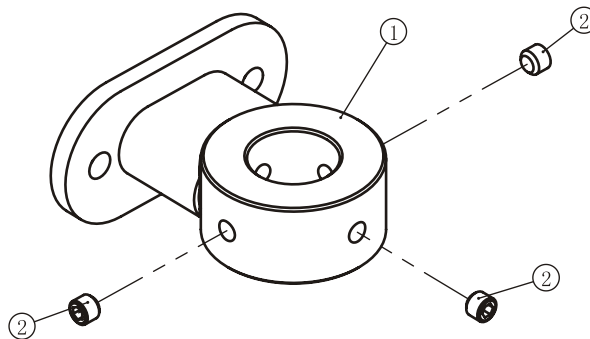

ItemNo.	Grade No.	Part No.	Description	QTY
1	8.1	IT95180800	Connecting Frame	1
2	8.2	GB77M10*8DS2	Screw M10*8	3

# Exploded View and Parts List

## Left Foot Frame ASSY

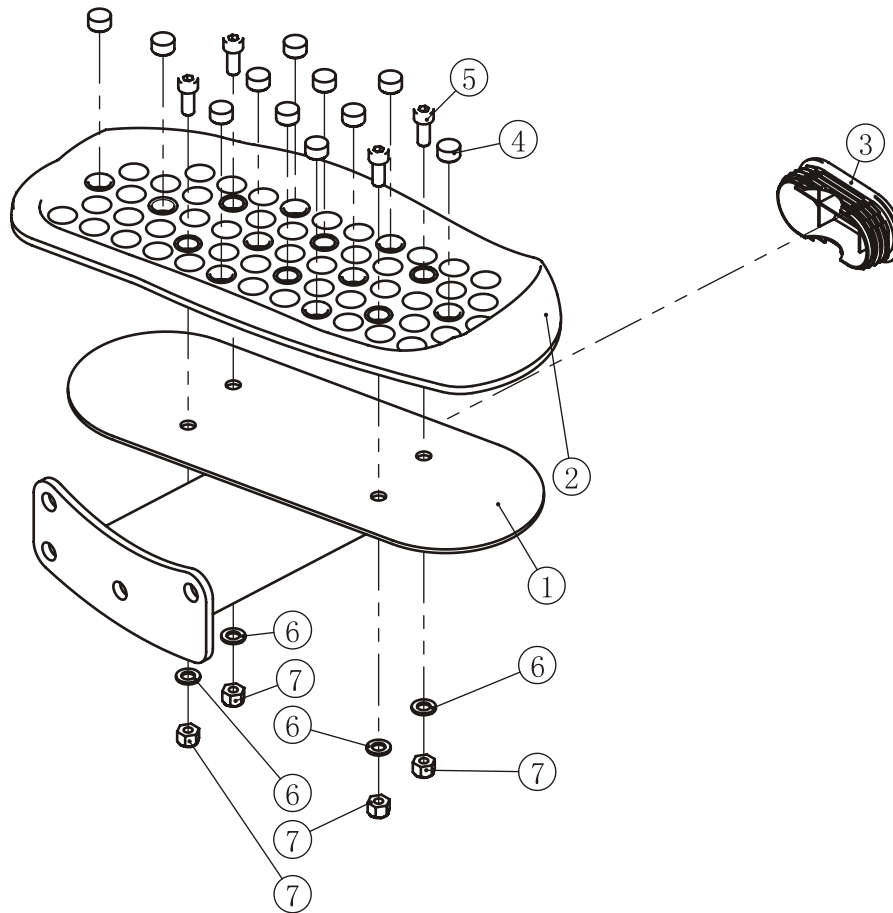

ItemNo.	Grade No.	Part No.	Description	QTY
1	5.1	IT95180500	Left Foot Frame	1
2	5.2	IW38800	Right pedal	1
3	5.3	IT90013800P11C	Plug RT50*100	1
4	5.4	IW38900	Pedal hole plug	11
5	5.5	GB70M8*20DN20	Socket Head Cap Screw M8*20	4
6	5.6	GB958DN2	Flat Washer $\phi 9^* \phi 16^*1.6$	4
7	5.7	NM8DN2	Nylon Lock Nut M8	4

# Exploded View and Parts List

## Wheel Frame ASSY

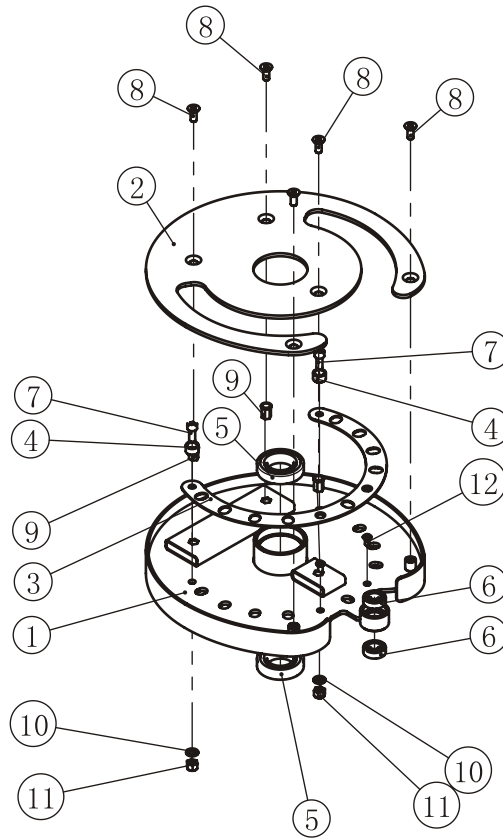

ItemNo.	Grade No.	Part No.	Description	QTY
1	6.1	IT95180600	Wheel Frame	1
2	6.2	IT95183200	Wheel cover plate	1
3	6.3	IT95183000	Adjustment plate 1	1
4	6.4	IN-S10111200	Rubber Sleeve $\phi 17*10.5$	2
5	6.5	GB2766007-2ZNBK	Bearing	2
6	6.6	GB2766200-2ZNBK	Bearing	2
7	6.7	GB70M8*20DN20	Socket Head Cap Screw M8*20	2
8	6.8	CNLM8*20N19	Flat Head Cap Screw M8*20	5
9	6.9	GB17880.5M8*16.5DCS17	Rivet Nut M8	3
10	6.10	GB958DN2	Flat Washer $\phi 9* \phi 16*1.6$	2
11	6.11	NM8DN2	Nylon Lock Nut M8	2
12	6.12	GB819M6*12N19	Screw M6*12	2

# Exploded View and Parts List

## Swivel Frame ASSY

ItemNo.	Grade No.	Part No.	Description	QTY
1	7.1	IT95180700	Swivel Frame	1
2	7.2	IT951809ASSY	Adjustment Handle Frame ASSY	1
3	7.3	IT95183300		1
4	7.4	IT95183600	Pin axle	1
5	7.5	IT95014500	Adjustable Support	1
6	7.6	CWRVL0012200	Pin axle	1
7	7.7	IT95014300	Aluminum Tube Guide	1
8	7.8	IT95016300	Plastic Corner Tube Guide	4
9	7.9	IT95016200	Plastic Tube Plug	1
10	7.10	GB2766007-2ZNBK	Bearing	2
11	7.11	IT80181702	Spring	1
12	7.12	AXT3S5500	Torsion Spring	1
13	7.13	GB894.18FH12	Circlips For Shaft $\phi$ 8	2
14	7.14	GB/T1243-199708BN19	Link 12.7	1
15	7.15	GB70M6*10N19	Socket Head Cap Screw M6*10	1
16	7.16	GB70BTM10*25DN18	Socket Head Cap Screw M10*25	1
17	7.17	GB70M8*50DS20	Socket Head Cap Screw M8*50	1
18	7.18	GB936DS12	Spring Washer $\phi$ 12	1
19	7.19	GB958DN2	Flat Washer $\phi$ 9* $\phi$ 16*1.6	2
20	7.20	NM8DN2	Nylon Lock Nut M8	1
21	7.21	KPS18002701	Lock Nut M20*1.5*18	1
22	7.22	M01402000	Spacer $\phi$ 25* $\phi$ 12.2*13	1

# Exploded View and Parts List

## Swivel Frame ASSY

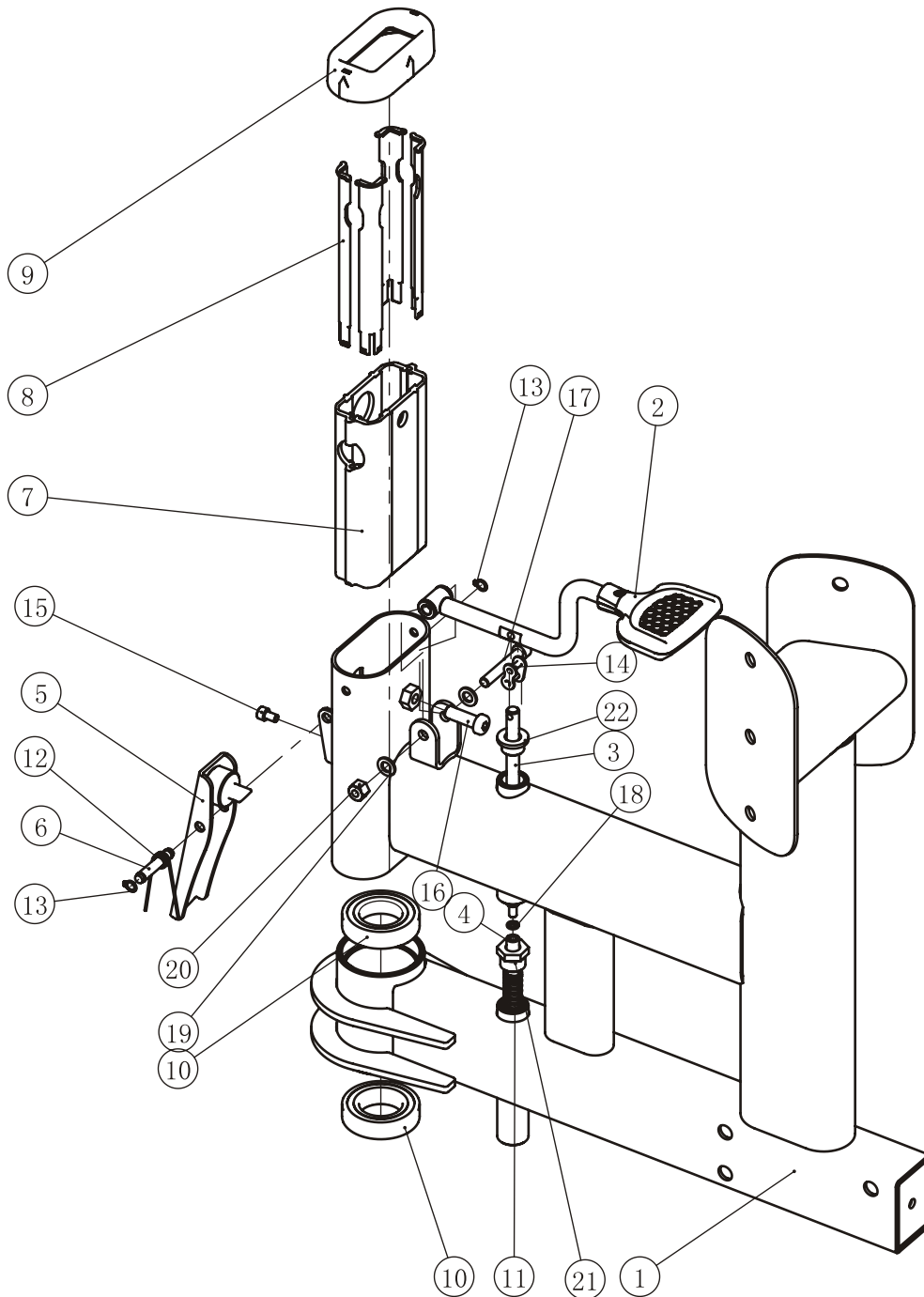



# Exploded View and Parts List

## Adjustment Handle Frame ASSY

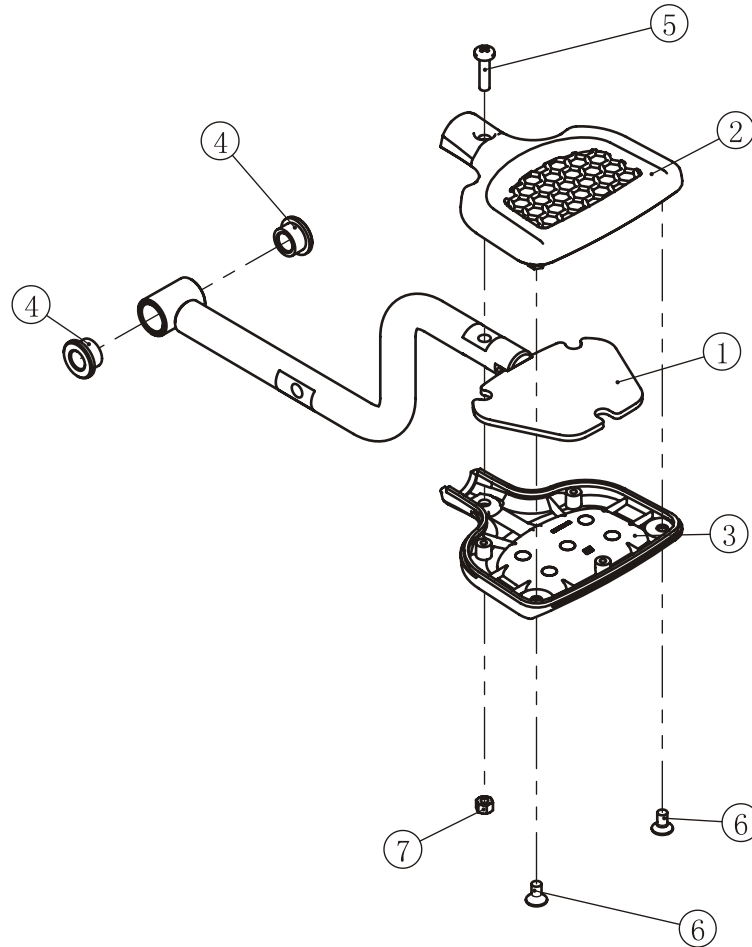

ItemNo.	Grade No.	Part No.	Description	QTY
1	7.2.1	IT95180900	Adjustment Handle Frame	1
2	7.2.2	FE970114200	Upper Regulation cover	1
3	7.2.3	FE970114100	Lower Regulation cover	1
4	7.2.4	P60015700	Spacer $\phi 16^* \phi 8^*8$	2
5	7.2.5	GB818M4*16DN2NL	Hexagon Nut M4	1
6	7.2.6	GB819M4*8DN2	Screw M4*8	2
7	7.2.7	GB41M4DN2	Hexagon Nut M4	1

# Exploded View and Parts List

## Right Foot Frame ASSY

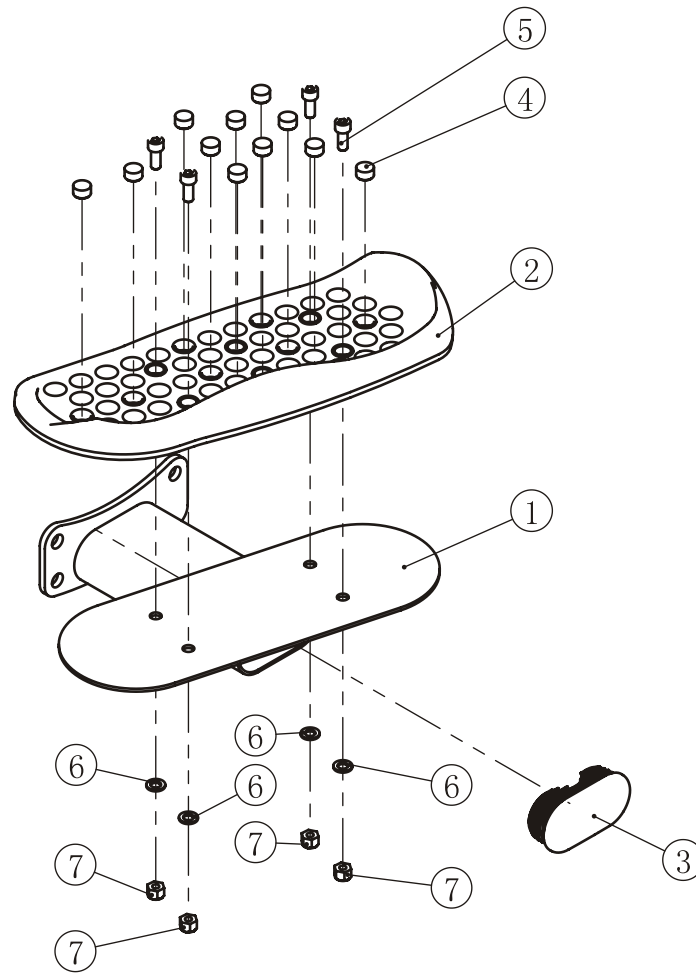

ItemNo.	Grade No.	Part No.	Description	QTY
1	9.1	IT95180500	Left Foot Frame	1
2	9.2	IW38700	Left pedal	1
3	9.3	IT90013800P11C	Plug RT50*100	1
4	9.4	IW38900	Pedal hole plug	11
5	9.5	GB70M8*20DN20	Socket Head Cap Screw M8*20	4
6	9.6	GB958DN2	Flat Washer $\phi 9^* \phi 16^*1.6$	4
7	9.7	NM8DN2	Nylon Lock Nut M8	4

# Measurement Guide

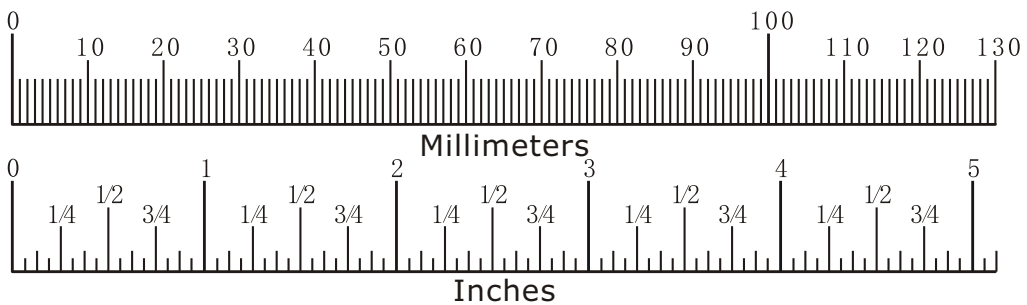
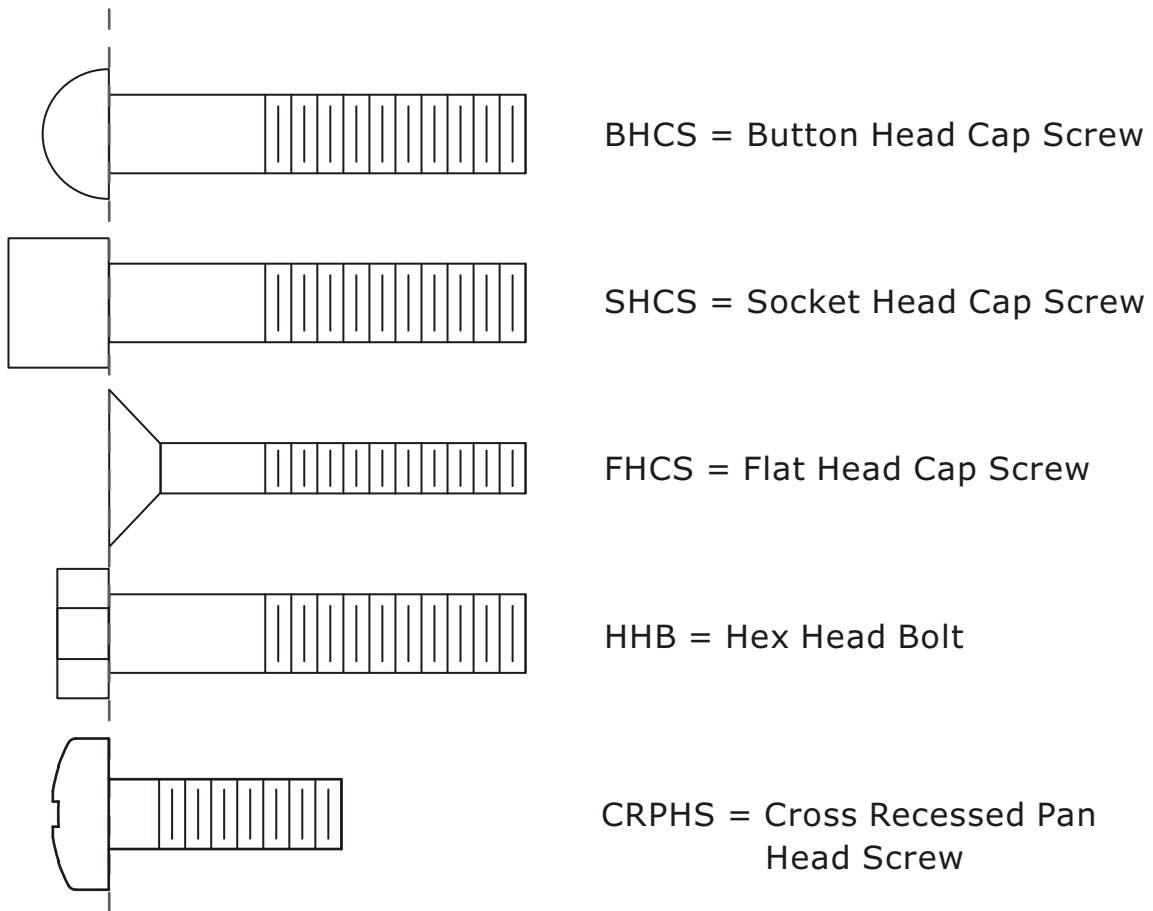

Diameter of bolt (mm/inch)	M6(1/4")	M8(5/16")	M10(3/8")	M12(1/2")	M16(5/8")
Tightening torque (N.m)	9~12	22~30	45~59	78~104	193~257
Operational methods for adult men	The strength of the wrist	The strength of the wrist and forearm	The strength of the entire arm	The strength of the arm and upper body	with all strength

# Assembly Instructions

Assembly of the equipment takes professional installers about 2 hours. If this is the first time you have assembled this type of equipment, plan to spend more time. It is strongly recommended to assemble the equipment by professional installers. You may find it quicker, safer, easier to assemble this equipment with the help of a friend, as some of components may be large, heavy or awkward to handle alone. It is important that you assemble your product in a clean, clear, uncluttered area. This will enable you to move around the product while you are fitting components and reduce the possibility of injury during assembly.

## **NOTE**

As with any assembled part, proper alignment and adjustment is critical. While tightening the fasteners, be sure to leave room for adjustments. Do not fully tighten the fasteners until instructed to do so. Be careful to assemble the components in the sequence presented in this guide.

# Assembly

## STEP 1

1. Attach two Adjustable Foot Plates (#14) to the Main Frame ASSY (#2).
2. Attach the Rear Bracket (#18) to the Top Rear Shroud (#55) using:  
two M6\*10 CRPHS (#42)

**Note: Wrench Tighten Bolts.**

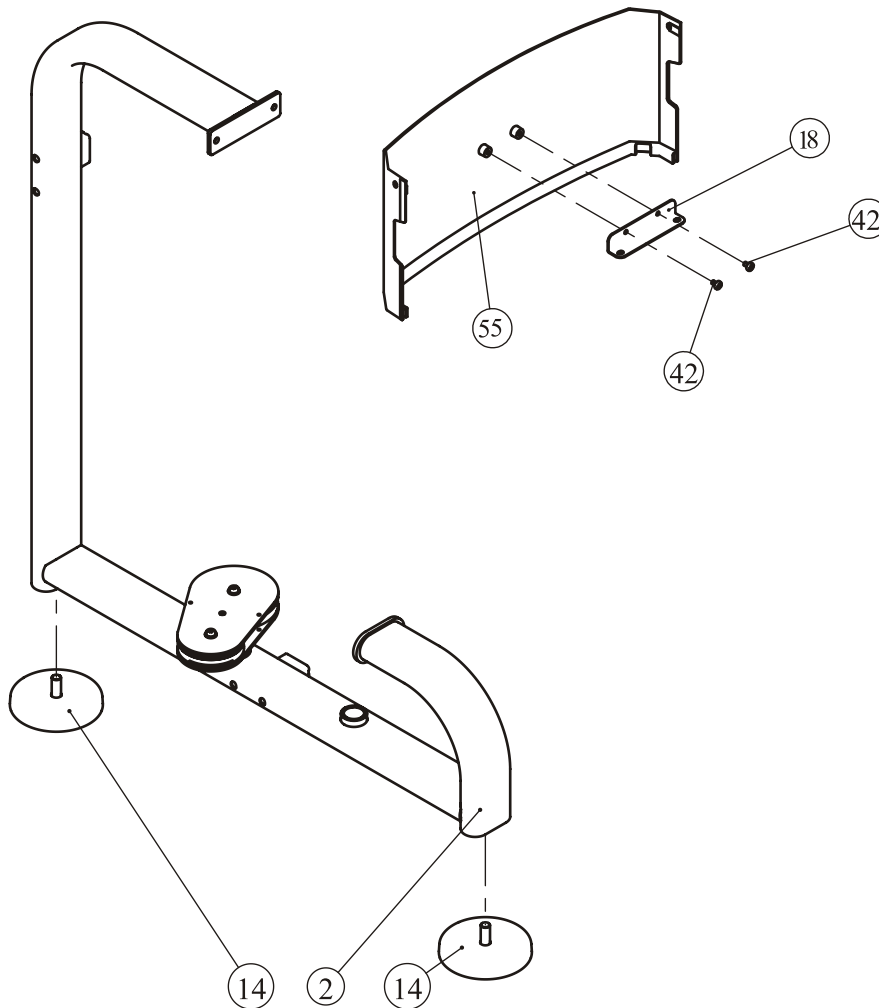



# Assembly

## STEP 3

1. Attach two Bottom Bracket ASSY (#13) to the Weight Stack Frame ASSY (#1) using:  
two M10\*75 SHCS (#36)                      four  $\Phi 11*\Phi 20*2$  Flat Washer (#46)  
two M10 Nylon Lock Nut (#50)
2. Attach the Top Bracket ASSY (#12) to the Weight Stack Frame ASSY (#1) using:  
two  $\Phi 9*\Phi 16*1.6$  Flat Washer (#45)      two M8\*20 SHCS (#32)
3. Attach the Seat Pad Support (#11) to the Swivel Frame ASSY (#7).
4. Attach the Wheel Frame ASSY (#6) and the Main Shaft (#16) to the Main Frame ASSY (#2) using:  
one Nylon Lock Nut M16 (#64)
5. Attach the Swivel Frame ASSY (#7) to the Main Frame ASSY (#2) using:  
two Short bushing (#30)
6. Attach the Connecting Frame ASSY (#8) to the Main Frame ASSY (#2) using:  
two M10\*25 SHCS (#34)
7. Attach the Main Shaft (#16) to the Main Frame ASSY (#2) and the Connecting Frame ASSY (#8) using:  
one M10\*25 SHCS (#34)                      one Circle Ring  $\Phi 62.5*5$  (#24)  
one Cap  $\Phi 60$  (#25)

**Note: Wrench Tighten Bolts and Nylon Lock Nuts.**

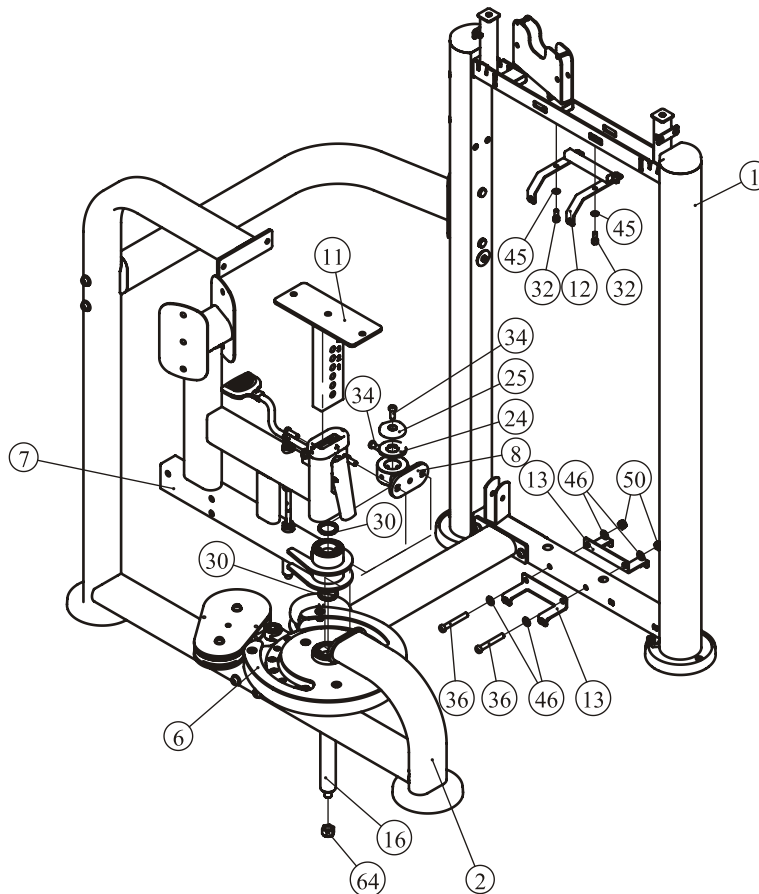

# Assembly

## STEP 4

1. Attach the Handle Frame ASSY (#4) to the Main Frame ASSY (#2) using:
  - two M12\*30 SHCS (#38)
  - four  $\Phi 13*\Phi 24*2.5$  Flat Washer (#47)
  - two M12 Nylon Lock Nut (#51)
2. Attach the Left Foot Frame ASSY (#5) and the Right Foot Frame ASSY (#9) to the Weight Stack Frame ASSY (#1) using:
  - two M12\*80 SHCS (#39)
  - six  $\Phi 13*\Phi 24*2.5$  Flat Washer (#47)
  - three M12 Nylon Lock Nut (#51)

**Note: Wrench Tighten Bolts and Nylon Lock Nuts.**

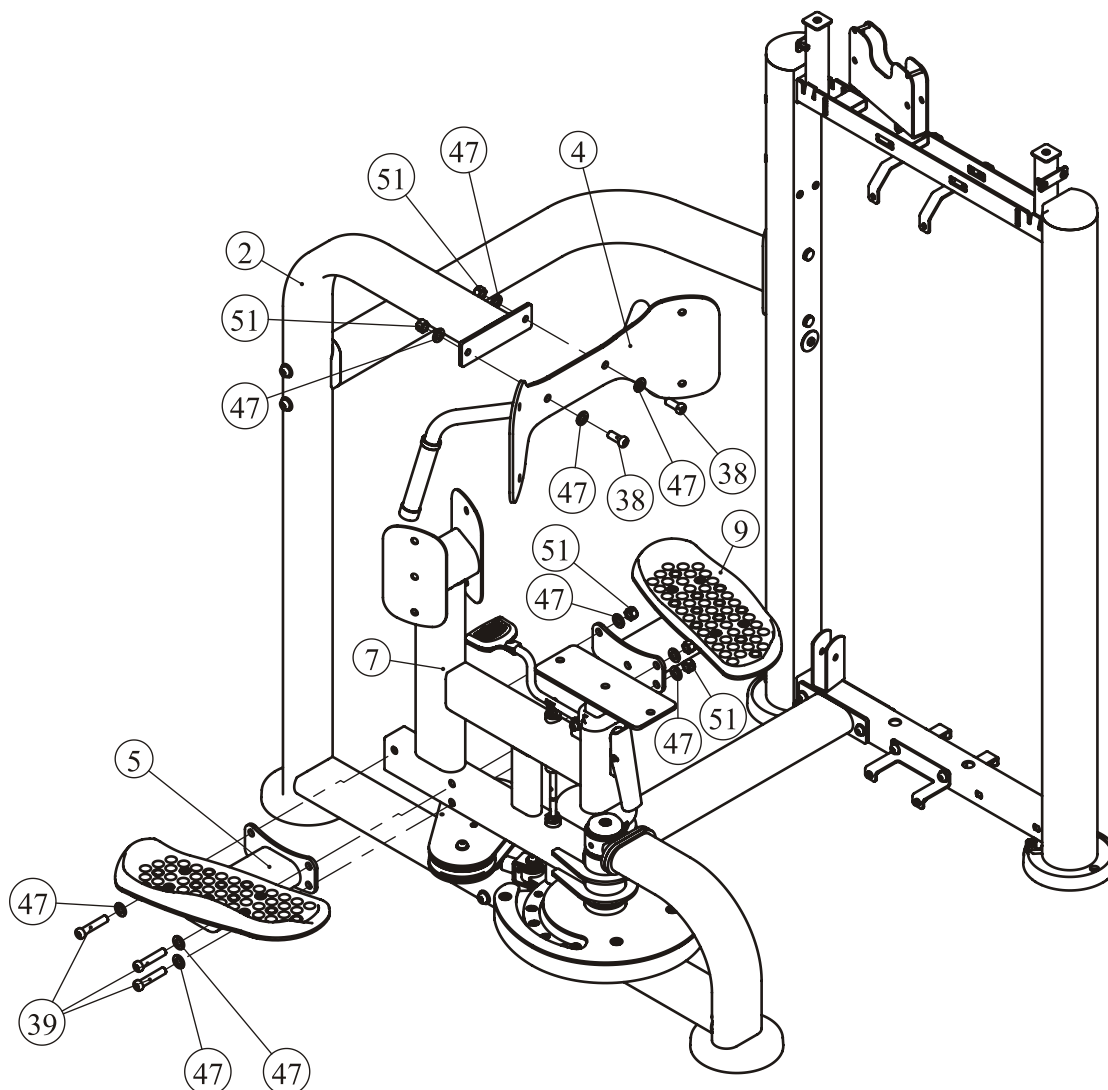



# Assembly

## STEP 5

Here is the assembly instruction for **160LBS Weights !**

### 1. Attach:

- two Guide Rod  $\Phi 19 \times 1242$  (#21)
- two Weight Rubber Bumper (#27)
- fifteen Weight Plate 10LBS (#73)
- two weight stack space (#75)
- two Weight Stack Space 300 (#62)
- one Top Plate (#23)

to the Weight Stack Frame ASSY (#1) using:

- two Guide Rod Fixing Sleeve  $\Phi 25 \times \Phi 19 \times 45$  (#28)
- two Spring (#49)

### 2. Attach the Selector Pin W/Coil (#26) to the Top Plate (#23).

Grade No.	Part No.	Description	QTY
73	FE97193100	10LBS Weight Plate	15
75	FEWS01ASSY	Weight Stack Space	2

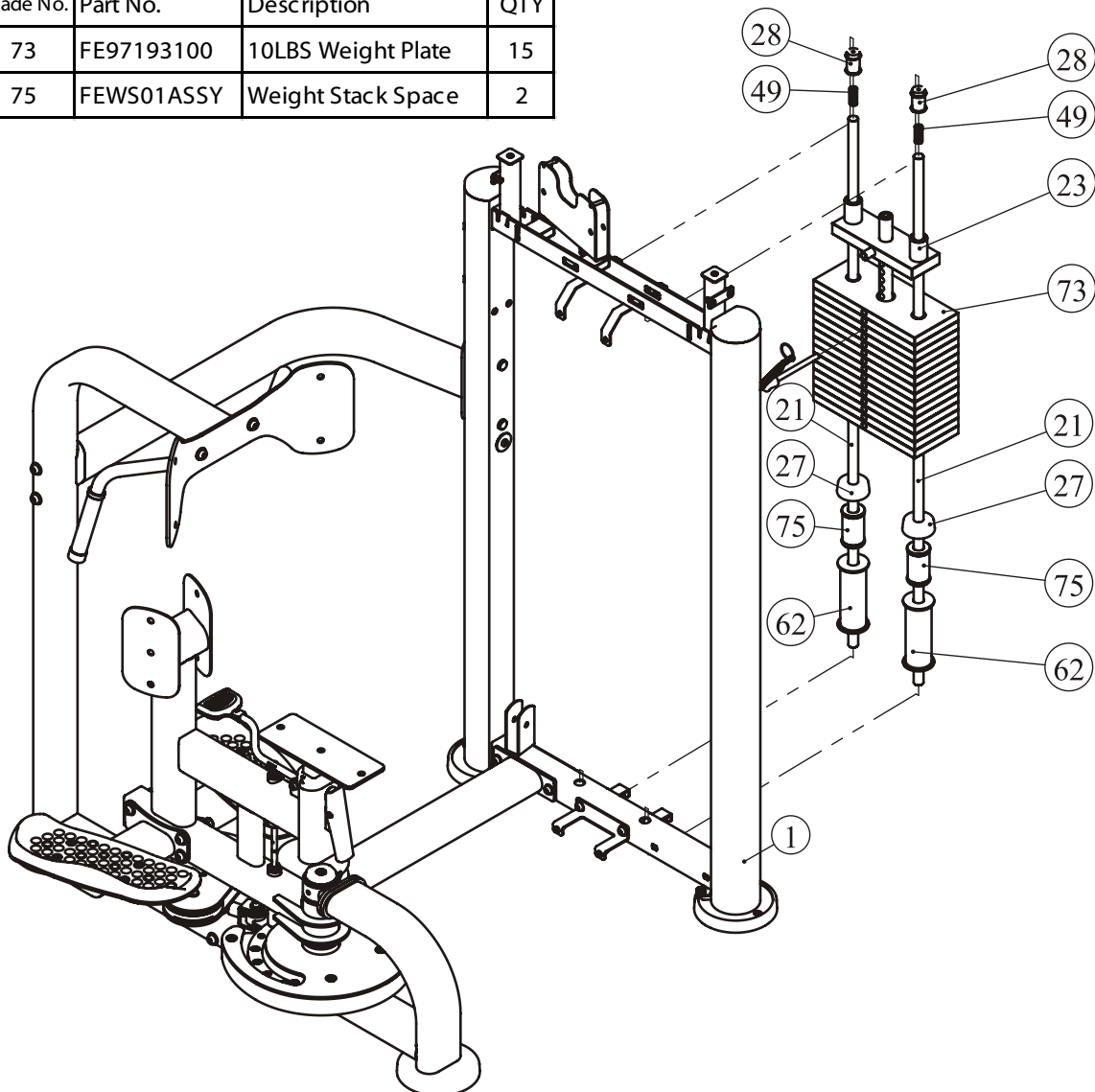

# Assembly

## STEP 5

Here is the assembly instruction for **200LBS Weights !**

### 1. Attach:

- two Guide Rod  $\Phi 19 \times 1242$  (#21)
- two Weight Rubber Bumper (#27)
- nineteen Weight Plate 10LBS (#73)
- two Weight Stack Space 300 (#62)
- one Top Plate (#23)

to the Weight Stack Frame ASSY (#1) using:

- two Guide Rod Fixing Sleeve  $\Phi 25 \times \Phi 19 \times 45$  (#28)
- two Spring (#49)

### 2. Attach the Selector Pin W/Coil (#26) to the Top Plate (#23).

Grade No.	Part No.	Description	QTY
73	FE97193100	10LBS Weight Plate	19

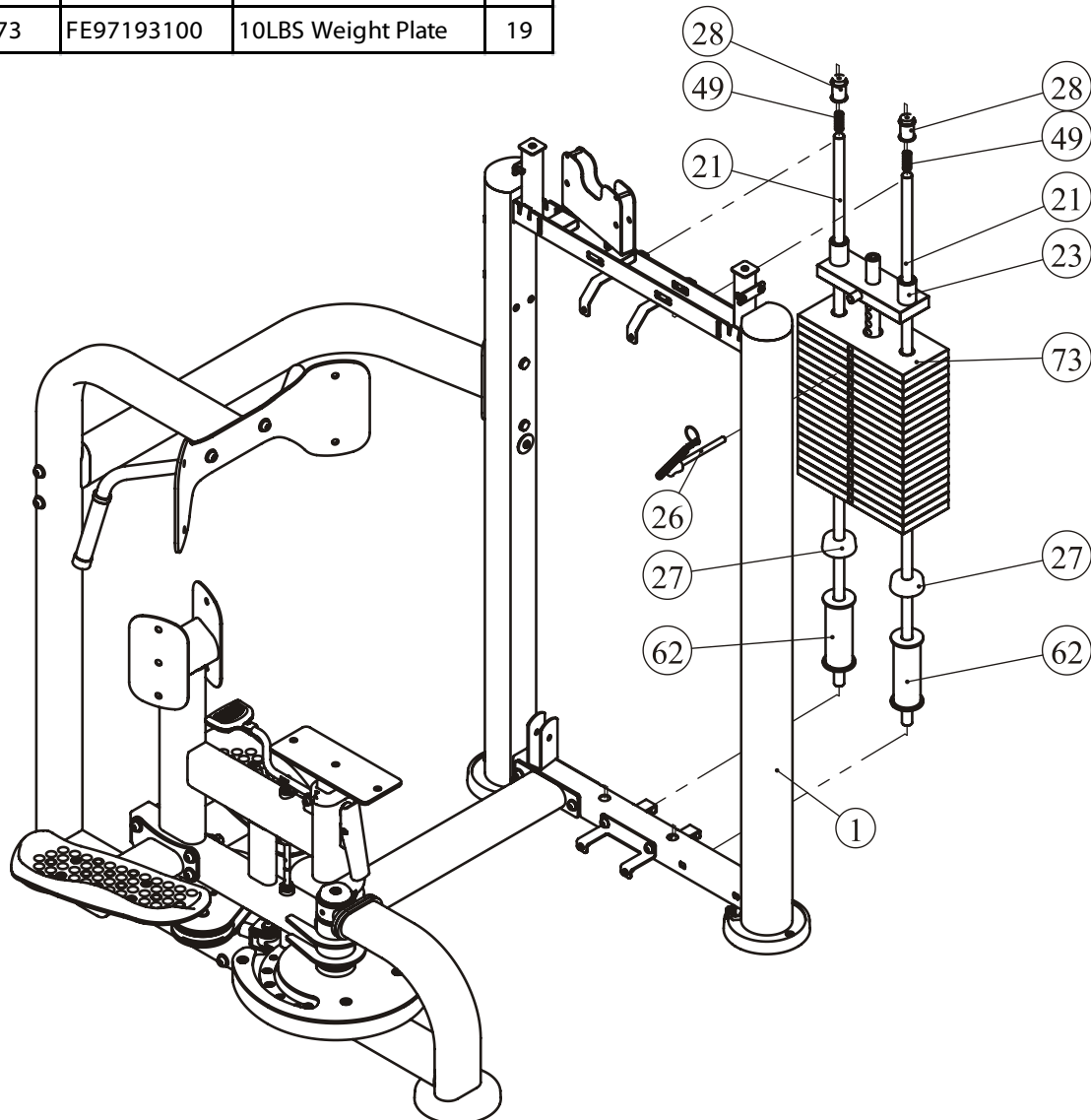

# Assembly

## STEP 5

Here is the assembly instruction for **235LBS Weights !**

### 1. Attach:

- two Guide Rod  $\Phi 19 \times 1242$  (#21)
- two Weight Rubber Bumper (#27)
- fifteen Weight Plate 15LBS (#76)
- two weight stack space (#75)
- two Weight Stack Space 300 (#62)
- one Top Plate (#23)

to the Weight Stack Frame ASSY (#1) using:

- two Guide Rod Fixing Sleeve  $\Phi 25 \times \Phi 19 \times 45$  (#28)
- two Spring (#49)

### 2. Attach the Selector Pin W/Coil (#26) to the Top Plate (#23).

Grade No.	Part No.	Description	QTY
76	FE97193200	15LBS Weight Plate	15
75	FEWS01ASSY	Weight Stack Space	2

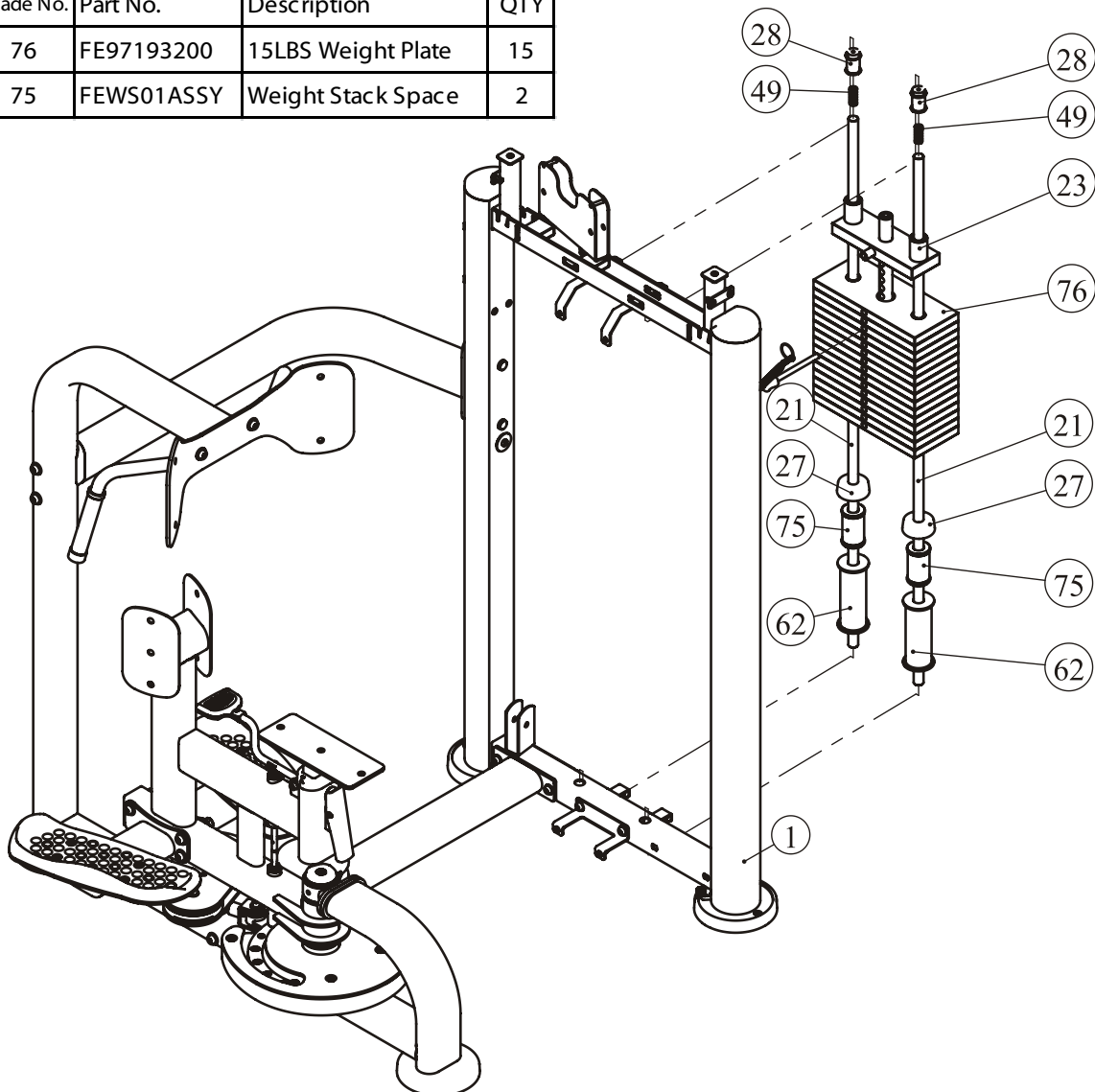

# Assembly

## STEP 5

Here is the assembly instruction for **295LBS Weights !**

### 1. Attach:

- two Guide Rod  $\Phi 19 \times 1242$  (#21)
- two Weight Rubber Bumper (#27)
- nineteen Weight Plate 15LBS (#76)
- two Weight Stack Space 300 (#62)
- one Top Plate (#23)

to the Weight Stack Frame ASSY (#1) using:

- two Guide Rod Fixing Sleeve  $\Phi 25 \times \Phi 19 \times 45$  (#28)
- two Spring (#49)

### 2. Attach the Selector Pin W/Coil (#26) to the Top Plate (#23).

Grade No.	Part No.	Description	QTY
76	FE97193200	15LBS Weight Plate	19

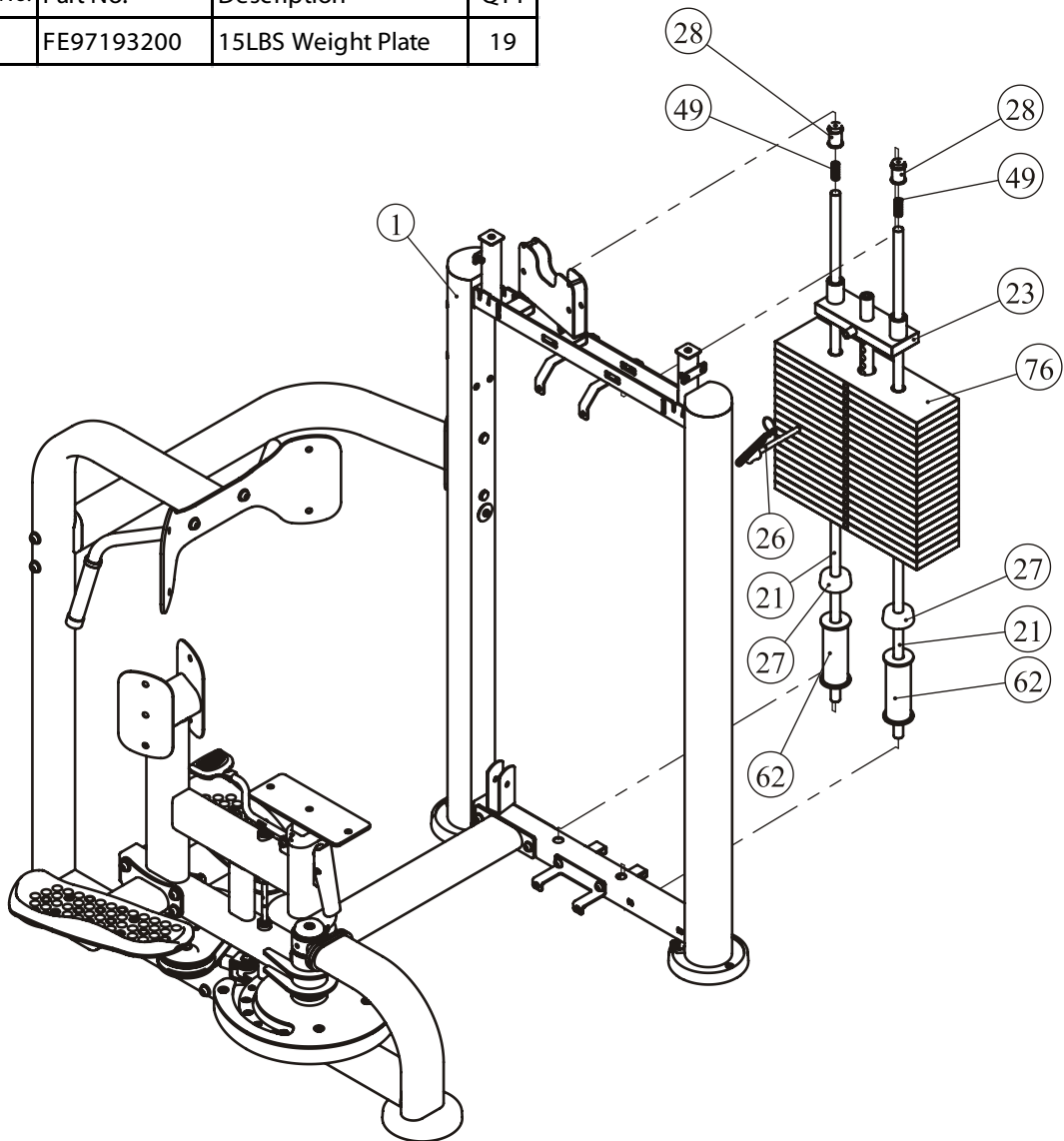

# Assembly

## All weight plate sticker paste schematic diagram

20 <sub>LBS</sub>	9
30 <sub>LBS</sub>	14
40 <sub>LBS</sub>	18
50 <sub>LBS</sub>	23
60 <sub>LBS</sub>	27
70 <sub>LBS</sub>	32
80 <sub>LBS</sub>	36
90 <sub>LBS</sub>	41
100 <sub>LBS</sub>	45
110 <sub>LBS</sub>	50
120 <sub>LBS</sub>	54
130 <sub>LBS</sub>	59
140 <sub>LBS</sub>	64
150 <sub>LBS</sub>	68
160 <sub>LBS</sub>	73
170 <sub>LBS</sub>	77
180 <sub>LBS</sub>	82
190 <sub>LBS</sub>	86
200 <sub>LBS</sub>	91
210 <sub>LBS</sub>	95
220 <sub>LBS</sub>	100
230 <sub>LBS</sub>	104

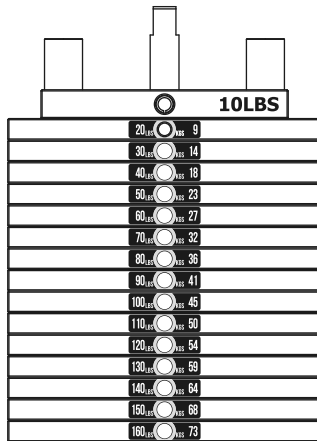

20-160LBS

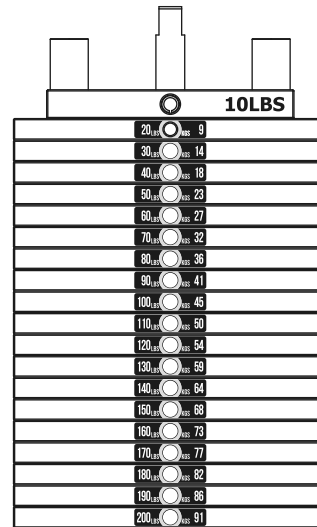

20-200LBS

25 <sub>LBS</sub>	11
40 <sub>LBS</sub>	18
55 <sub>LBS</sub>	25
70 <sub>LBS</sub>	32
85 <sub>LBS</sub>	38
100 <sub>LBS</sub>	45
115 <sub>LBS</sub>	52
130 <sub>LBS</sub>	59
145 <sub>LBS</sub>	66
160 <sub>LBS</sub>	72
175 <sub>LBS</sub>	79
190 <sub>LBS</sub>	86
205 <sub>LBS</sub>	93
220 <sub>LBS</sub>	100
235 <sub>LBS</sub>	107
250 <sub>LBS</sub>	113
265 <sub>LBS</sub>	120
280 <sub>LBS</sub>	127
295 <sub>LBS</sub>	134
310 <sub>LBS</sub>	141
325 <sub>LBS</sub>	147

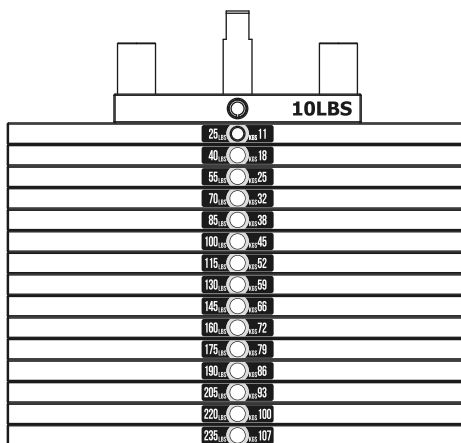

25-235LBS

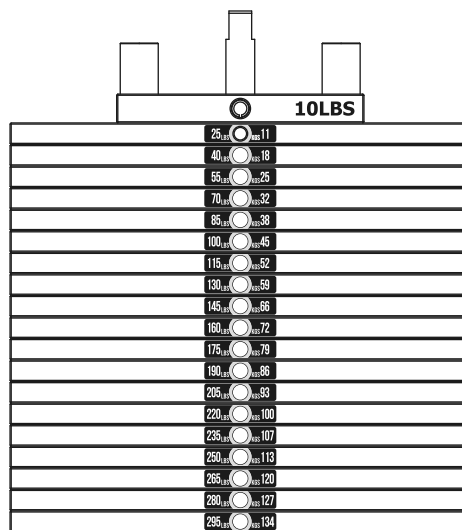

25-295LBS

# Assembly

## Step 6

1. Attach three 4.5" Pulleys (#19) to the Weight Stack Frame ASSY (#1) using:  
three M10\*50 SHCS (#35)                      six  $\Phi$ 11\* $\Phi$ 20\*2 Flat Washer (#46)  
three M10 Nylon Lock Nut (#50)
2. Attach the Cable ASSY (#60) to the Top Plate (#23) and the Wheel Frame ASSY (#6) using:  
one Short bushing (#31)                      one Nylon Lock Nut M8 (#52)  
one Cap (#48)                                      one Cable Connecting Frame (#15)  
one Aluminium Sheath  $\Phi$ 14.5\*27 (#74)

**Note: Wrench tighten bolts and Nylon Lock Nuts.**

## Step 7

**Tips:** Pre-assemble eight M6\*20 Cross Recessed Pan Head Screws into the Weight Stack Frame ASSY and Bottom Bracket ASSY, not wrench tighten Bolts, Assemble the shroud with the bolt on.

1. Attach the Front Shroud (#56) and the Left Front Shroud (#57) to the Weight Stack Frame ASSY (#1) and the Bottom Bracket ASSY (#13) using:  
four M6\*20 CRPHS (#44)                      two M6\*16 CRPHS (#43)
2. Attach the Rear Shroud (#58) to the Weight Stack Frame ASSY (#1) and the Bottom Bracket ASSY (#13) using:  
four M6\*20 CRPHS (#44)                      two M6\*16 CRPHS (#43)
3. Attach the Training Placard Cover (#54) to the Weight Stack Frame ASSY (#1) and the Top Bracket ASSY (#12) using:  
two M6\*20 CRPHS (#44)                      two M6\*10 CRPHS (#42)
4. Attach the Top Rear Shroud (#55) to the Weight Stack Frame ASSY (#1) and the Top Bracket ASSY (#12) using:  
four M6\*20 CRPHS (#44)
5. Attach the Top Cover (#59) to the Weight Stack Frame ASSY (#1) using:  
two M6\*20 CRPHS (#44)                      two Spout Plug  $\Phi$ 16.5\*6.88 (#63)
6. Attach the Cup Holder (#53) to the Weight Stack Frame ASSY (#1) using:  
two M6\*20 CRPHS (#44)

# Assembly

## STEP 6

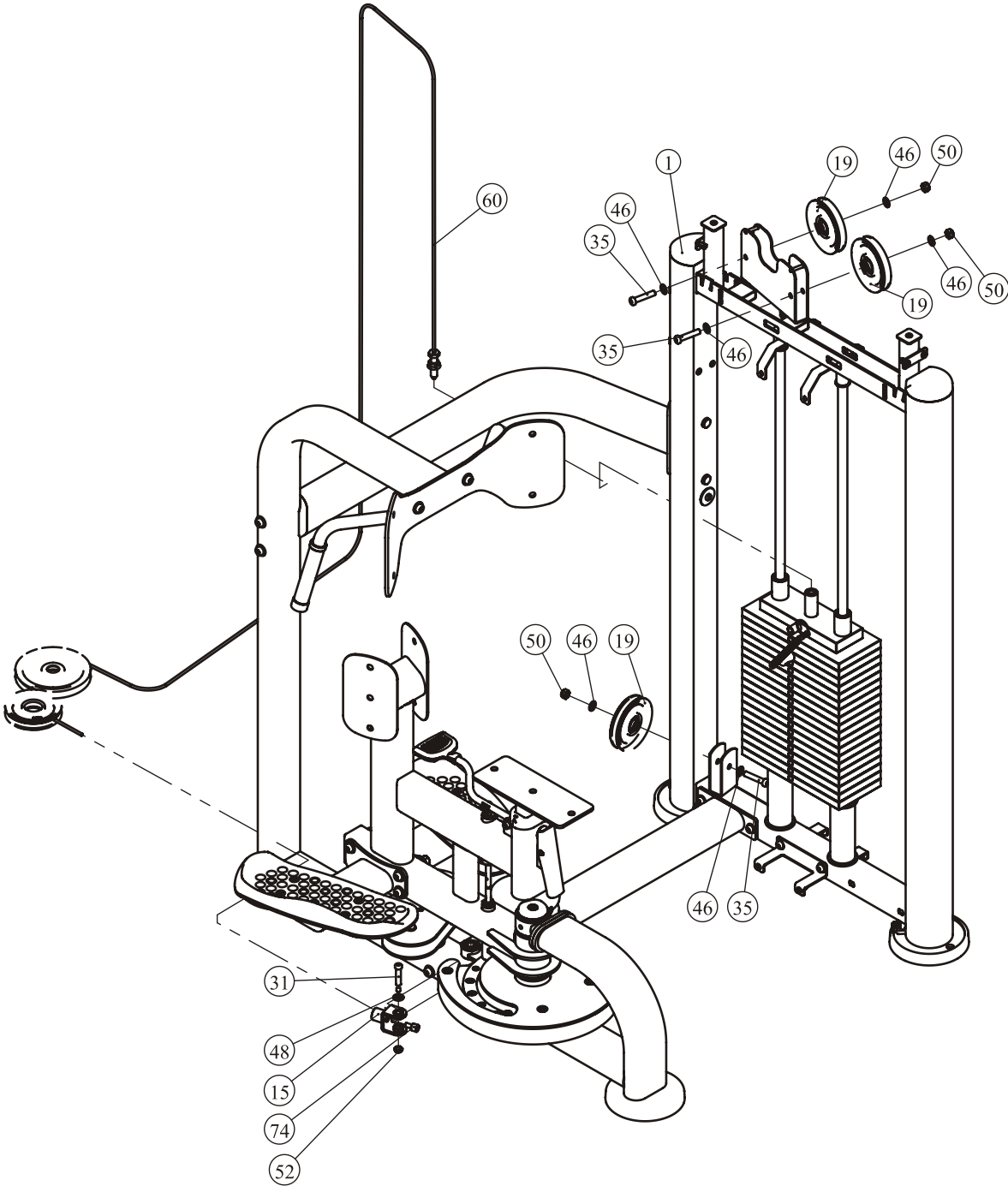





# Assembly

## STEP 8

1. Attach two Arm Pad (#61) to the Handle Frame ASSY (#4) using:
  - four M10\*30 SHCS (#41)
  - four  $\Phi 11*\Phi 20*2$  Flat Washer (#46)
2. Attach the Seat Pad (#17) to the Main Frame (#2) using:
  - two M10\*30 SHCS (#41)
  - two  $\Phi 11*\Phi 20*2$  Flat Washer (#46)
3. Attach two Arm Pad (#61) to the Swivel Frame ASSY (#7) using:
  - two M10\*30 SHCS (#41)
  - two M10\*25 HHB (#33)
  - four  $\Phi 11*\Phi 20*2$  Flat Washer (#46)

**Note: Wrench tighten bolts and Nylon Lock Nuts.**

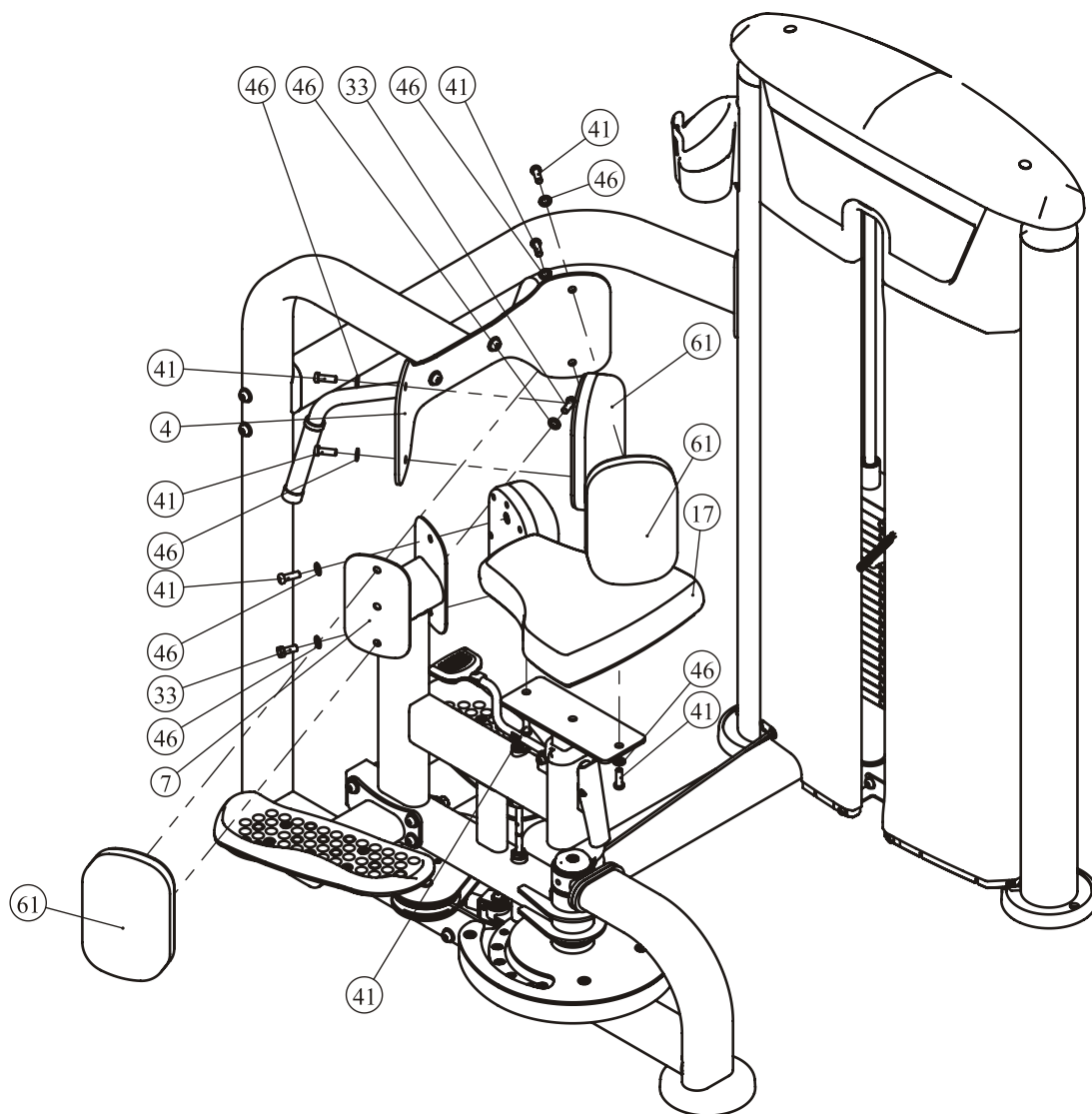

# Adjust Instructions

## The Seat Pad adjustment

1. Push the Adjustable Support and adjust the Seat Pad to the desired position.
2. Make sure the pin gets into the hole completely.

## The Swivel Frame adjustment

1. Pull the Adjustment Handle Frame ASSY and adjust the Swivel Frame to the desired position.
2. Make sure the pin gets into the hole completely.

## The use of Selector Pin W/Coil

1. Select an appropriate weight and put the Selector Pin W/Coil into the hole on it.
2. Make sure the Selector Pin W/Coil gets into the hole completely.

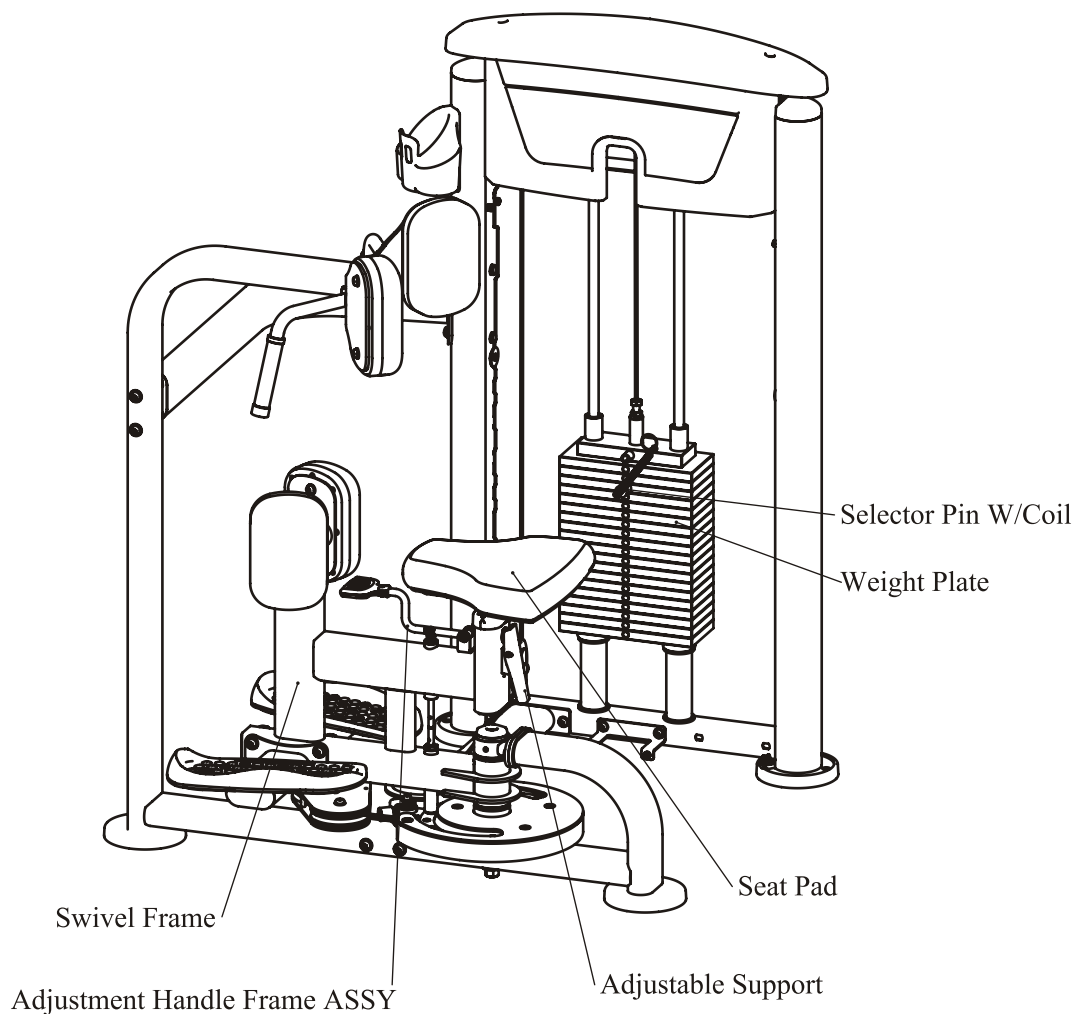

# Exercise Instructions

**TORSO ROTATION**

1. Select the appropriate weight.
2. Adjust the seat pad to desired position.
3. Select the desired startup position. Hold handle, move slowly toward center from right/left side.
4. Slowly return to the starting position.

Start      Finish

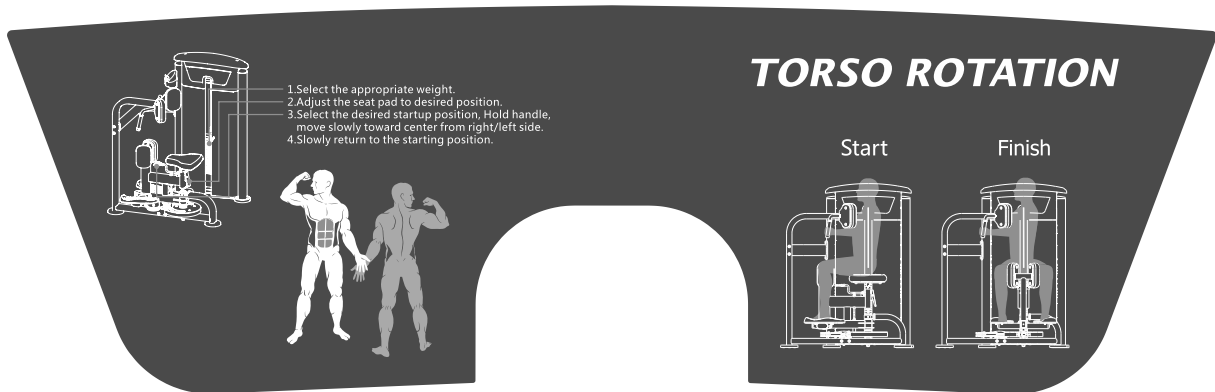

1. Select the appropriate weight.
2. Adjust the seat pad to desired position.
3. Select the desired startup position, Hold handle, move slowly toward center from right/left side.
4. Slowly return to the starting position.

Start      Finish

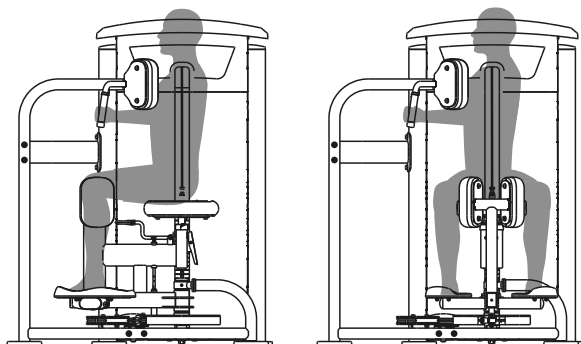
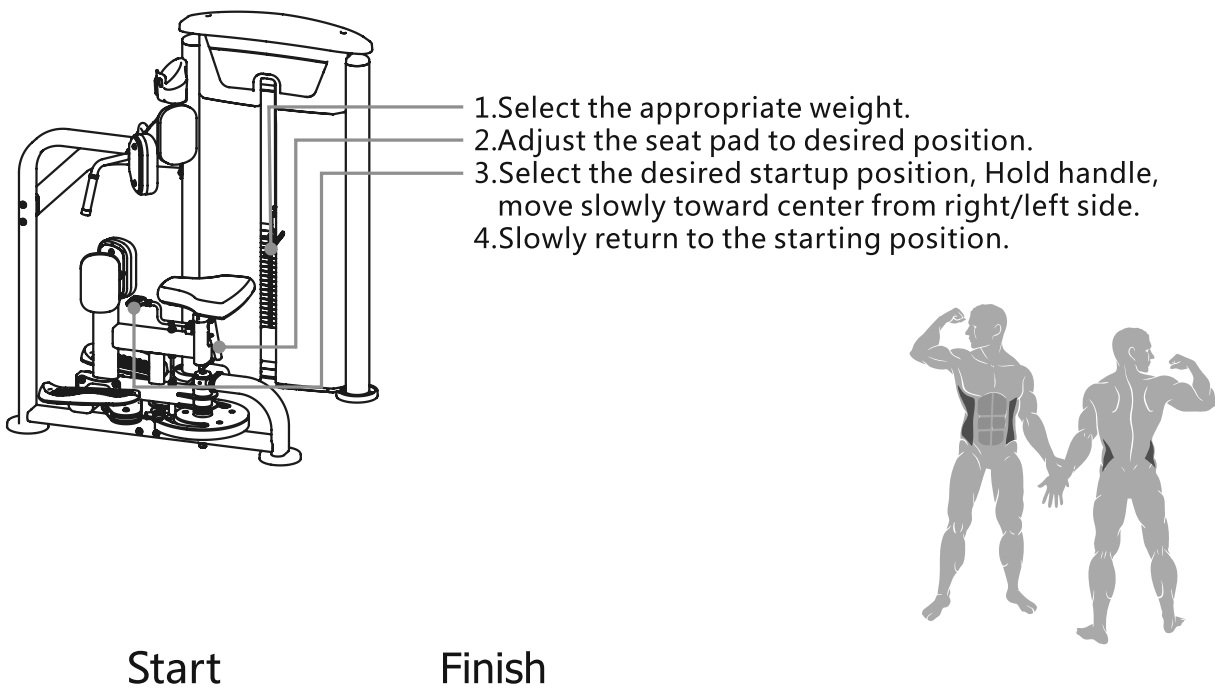

# Maintenance Schedule

ROUTINE	COMMERCIAL MAINTENANCE	HOME MAINTENANCE	LATEST DATE ENTRY						
Inspect; Links, Pull Pins, Snap Locks, Swivels, Weight Stack Pins	DAILY	WEEKLY							
Clean; Upholstery	DAILY	WEEKLY							
Inspect; Cables or Belts and their tension	DAILY	WEEKLY							
Inspect; Accessory Bars, and Handles	WEEKLY	3 MONTHS							
Inspect; All Decals	WEEKLY	3 MONTHS							
Inspect; All Nuts and Bolts, Tighten if needed	WEEKLY	3 MONTHS							
Inspect; Anti-Skid Surface	WEEKLY	3 MONTHS							
Clean & Lubricate; Guide Rods with a Teflon (PTFE) based lubricant (Superlube)	MONTHLY	3 MONTHS							
Lubricate; Seat Sleeves, Turcite Bushings, Linear Bearing	MONTHLY	3 MONTHS							
Clean and Wax; All Glossy Finishes	6 MONTHS	YEARLY							
Repack with Grease; Linear Bearings	6 MONTHS	YEARLY							
Replace; Cables, Belts and Connecting Parts	YEARLY	3 YEARS							

*Your equipment comes with a commercial maintenance decal. For personal, in home use, please follow the home maintenance schedule listed above.*

# General Maintenance Information

## **Links, Pull-Pins, Snap Hooks, Swivels, Weight Stack Pins:**

- \* Check all pieces for signs of visible wear or damage.
- \* Check springs in snap hooks and pull-pins for proper tension and alignment.
- \* If the spring sticks or has lost its rigidity, replace it immediately.

## **Upholstery:**

- \* To ensure prolonged upholstery life and proper hygiene, all upholstered pads should be wiped down with a damp cloth after every workout.
- \* Periodically take the time to use a mild soap or an approved vinyl upholstery cleaner to deter the onset of cracking or drying. Avoid using any abrasive cleaners or cleaners not intended for use on vinyl.
- \* Replace ripped or worn upholstery immediately.
- \* Keep sharp or pointed objects clear of all upholstery.

## **Decals:**

- \* Inspect and familiarize yourself with any safety warnings or other user information posted on each decal.

## **Nuts and Bolts:**

- \* Inspect all nuts and bolts for any loosening and tighten if needed.
- \* Go through a re-tightening sequence periodically to ensure that all hardware is tensioned proper.

## **Anti-Skid Surfaces:**

- \* These surfaces are designed to supply secure footing and need to be replaced if they appear worn or become slippery.

## **Belts and Cables:**

- \* We use only high quality belt, and mil-spec cables.
- \* Visually inspect the belts and cables for fraying, cracking, peeling or discoloration.
- \* While the machine is not in use, carefully run your fingers along the belt or cable to feel for thinning or bulging areas.
- \* Replace belts and cables immediately at the first signs of damage or wear. Do not use equipment until belts or cables have been replaced.

## **Belt and Cable Tension:**

- \* Referring to the Owners Manual, when belts or cables are used check all bolts attachments to be sure they are properly attached.
- \* Check slack in cables and re-adjust cable tension if needed.

## **Seat Sleeves, Guide Rods:**

- \* Wipe down adjusting tubes with a dust free rag before applying lubricant.
- \* Lubricate seat sleeves and Guide Rods with a Silicon or Teflon based lubricant spray.

## **Linear Bearings:**

- \* Referring to the Owners Manual carefully disassemble the bearing from its housing and place a finger full of light grease (lithium, super lube, etc.) into the inside of the bearing. Using your finger, press the grease into the ball-bearings and their tracks. Repeat until the ball-bearing tracks are full of grease. Insert the shaft back into the bearing and wipe off excess grease.

**PLEASE KEEP THIS FOR YOUR RECORDS**

## Weight Training Tips

Use this manual to guide you through the basic exercises you can perform on your equipment. To gain maximum results and avoid possible injury, consult a fitness professional to develop your complete exercise program.

Always consult your physician before starting any exercise program.

To be successful in your exercise program, it is important to develop an understanding of the basic principles of strength training. Now that you have your equipment, it is only natural that you want to get started immediately. First, determine a set of realistic goals and objectives for yourself. By deciding on an exercise plan that is right for you prior to starting, you will contribute significantly to your success.

Warm up properly before engaging in weight resistance training. Stretching, yoga, jogging, calisthenics or other cardiovascular exercise can help prepare your body for the heavier workload of lifting weights.

Learn how to perform the exercise correctly before using heavy weight. Correct form is important to avoid injury and to ensure that you work the proper muscle groups.

Know your limitations. If you are new to weight training or are embarking on an exercise regimen after a long layoff, start slowly and build foundational strength over a longer period of time.

Pay attention to your breathing. Exhale when you exert is a general rule of thumb. Never hold your breath.

