

TAURUS®

Assembly and Operating Instructions

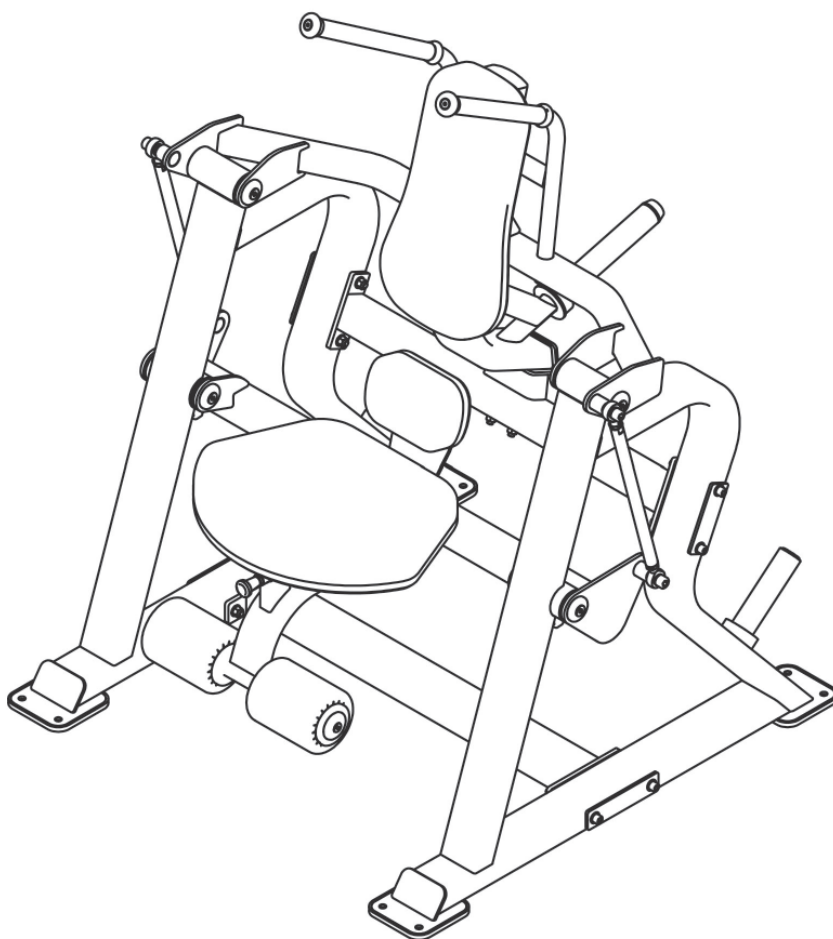

max. 150 kg



~ 90 Min.



132 kg

L 162 | W 127 | H 164

TfSL7036.01.01

Art. No. TF-SL7036

Taurus Iso Abdominal Sterling

Content

1	GENERAL INFORMATION	7
1.1	Technical Data	7
1.2	Personal Safety	8
1.3	Set-Up Place	9
2	ASSEMBLY	10
2.1	General Instructions	10
2.2	Scope of Delivery	10
2.3	Assembly	13
3	STORAGE AND TRANSPORT	22
3.1	General Instructions	22
4	TROUBLESHOOTING, CARE AND MAINTENANCE	23
4.1	General Instructions	23
4.2	Faults and Fault Diagnosis	23
4.3	Maintenance and Inspection Calendar	24
5	DISPOSAL	24
6	RECOMMENDED ACCESSORIES	25
7	ORDERING SPARE PARTS	26
7.1	Serial Number and Model Name	26
7.2	Parts List	27
7.3	Exploded Drawing	31
8	WARRANTY	35
9	CONTACT	37

Dear customer,

Thank you for choosing quality training equipment from the TAURUS brand. Taurus offers sports and fitness equipment for home users with high demands on quality, functionality and longevity. Also, Taurus is a well-known and experienced brand for equipping professional rooms for fitness studios and business customers. The focus of Taurus fitness equipment is on what matters most in sports: maximum performance! Therefore, the devices are developed in close consultation with athletes and sports scientists. Because athletes know best what makes perfect fitness equipment.

Further information can be found at www.taurus-fitness.com.

Intended Use

The equipment may only be used for its intended purpose.

This fitness equipment is suitable for home use, semi-professional use and commercial or professional use. The semi-professional sector includes, for example, institutional facilities such as hospitals, schools, hotels and associations. Professional use refers to commercial use, e.g. in a fitness studio.

Disclaimer

©2011 Taurus® is a registered brand of the company Sport-Tiedje GmbH. All rights reserved. Any use of this trademark without the explicit written permission of Sport-Tiedje is prohibited.

Product and manual are subject to change. Technical data can be changed without advance notice.

ABOUT THIS MANUAL

Please carefully read the entire manual before installation and first use. The manual will help you to quickly set up the system and explains how to safely use it. Make sure that all persons exercising with the equipment (especially children and persons with physical, sensory, mental or motor disabilities) are informed about this manual and its contents in advance. In case of doubt, responsible persons must supervise the use of the equipment.

Due to ongoing changes and software optimisations, the manual may have to be updated. If you notice any discrepancies during assembly or use, please refer to the manual uploaded to the webshop. The latest manual is always available there.

This equipment has been manufactured according to the latest safety knowledge. As far as possible, potential safety hazards which could cause injury have been eliminated. Make sure to carefully follow the instructions and that all parts are securely in place. If required, read through the instructions again to correct any mistakes.



Please pay close attention to the safety and maintenance instructions given here. The contract partner cannot be held liable for damage to health, accidents or damage to the equipment when it is not used in accordance with these instructions.

The following safety instructions may appear in this manual:

► **ATTENTION**

This notice indicates potentially hazardous situations which, if not avoided, may result in property damage.

⚠ **CAUTION**

This notice indicates potentially hazardous situations which, if not avoided, may result in slight or minor injuries!

⚠ **WARNING**

This notice indicates potentially hazardous situations which, if not avoided, may result in death or serious injuries!

⚠ **DANGER**

This notice indicates potentially hazardous situations which, if not avoided, will result in death or serious injuries!

ⓘ **NOTICE**

This notice indicates further useful information.

Retain these instructions in a safe place for future reference, maintenance or when ordering replacement parts.

1.1 Technical Data

Weight and Dimensions

Packaging dimensions (L x W x H) and article weight (gross, incl. packaging) approx.:

Box 1:	127.5 cm x 116.5 cm x 33 cm	75.8 kg
Box 2:	133.5 cm x 76.5 cm x 45 cm	75 kg

Set-up dimensions (L x W x H) approx.: 162 cm x 127 cm x 164 cm

Article weight (net, excl. packaging) approx.: 132 kg

Maximum user weight:	150 kg
Maximum load weight:	120 kg
Maximum storage load weight:	100 kg each

Class: S

NOTICE

This equipment is compatible with weight plates with a 50 mm hole and a maximum external diameter of 450 mm (not included in the scope of delivery).

1.2 Personal Safety

DANGER

- + Before you start using the equipment, you should consult your physician that this type of exercise is suitable for you from a health perspective. Particularly affected are persons who: have a hereditary disposition to high blood pressure or heart disease, are over the age of 45, smoke, have high cholesterol values, are overweight and/or have not exercised regularly in the past year. If you are under medical treatment that affects your heart rate, medical advice is absolutely essential.
- + Note that excessive training can seriously endanger your health. Please also note that heart rate monitoring systems can be inaccurate. If you notice any signs of weakness, nausea, dizziness, pain, shortness of breath, or other abnormal symptoms, stop exercising immediately and seek advice from your doctor if necessary.
- + The owner must communicate all warnings and instructions to the user.

WARNING

- + This equipment may not be used by children under the age of 14.
- + Children should not be allowed unsupervised access to the equipment.
- + Persons with disabilities must have a medical license and must be under strict observation when using the equipment.
- + The equipment is strictly for use by one person at a time.
- + If your equipment provides a safety key, the clip of the safety key must be attached to your clothing before starting your training. In the event of a fall, the EMERGENCY STOP of the equipment can be initiated.
- + Keep your hands, feet and other body parts, hair, clothing, jewellery and other objects well clear of moving parts.
- + During use, wear suitable sports clothing rather than loose or baggy clothing. When wearing sports shoes, make sure they have suitable soles, preferably made of rubber or other non-slip materials. Shoes with heels, leather soles, studs or spikes are unsuitable. Never exercise barefoot.
- + Always start each workout with a light warm-up and end with a cool-down phase.
- + Using the machine as a support during stretching exercises or attaching resistance bands, ropes or other accessories to it, may cause injuries.

CAUTION

- + If your equipment needs to be connected to the power supply with a mains cable, make sure that the cable is not a potential tripping hazard.
- + Make sure that nobody is within the range of motion of the equipment during training so as not to endanger you or other persons.
- + Be aware that if adjustment devices are left protruding, they may impede the user's movement.

ATTENTION

- + Do not insert any objects of any kind into the openings of the device.

1.3 Set-Up Place

⚠ WARNING

- + Do not place the equipment in main corridors or escape routes.

⚠ CAUTION

- + Choose a location in which to place the equipment such that there is enough free space/clearance to the front, the rear and to the sides of the equipment.
- + The training room should be well ventilated during training and not be exposed to any draughts.
- + Choose the place in which to set up the equipment such that there is enough free space/clearance to the front, the rear and to the sides of the equipment.
- + The free area in the direction from which the exercise equipment is accessed must be at least 0.6 m larger than the exercise area.
- + The set-up and mounting surface of the equipment should be flat, loadable and solid.
- + If your device is to be mounted on the wall/ceiling, make sure that you use the appropriate assembly material to avoid possible damages or personal injuries. The contractual partner accepts no liability for this.

▶ ATTENTION

- + The device may only be used in one building, in sufficiently tempered and dry rooms (ambient temperatures between 10°C and 35°C). The equipment should not be used outdoors or in rooms with high humidity (over 70%) like swimming pools.
- + A floor protective mat/equipment underlay can help to protect high-quality floor coverings (parquet, laminate, cork, carpets) from dents and sweat and can help to level out slight unevenness.
- + For Class S and I equipment, the exercise equipment may only be used in areas where access, supervision and control are specifically regulated by the owner.

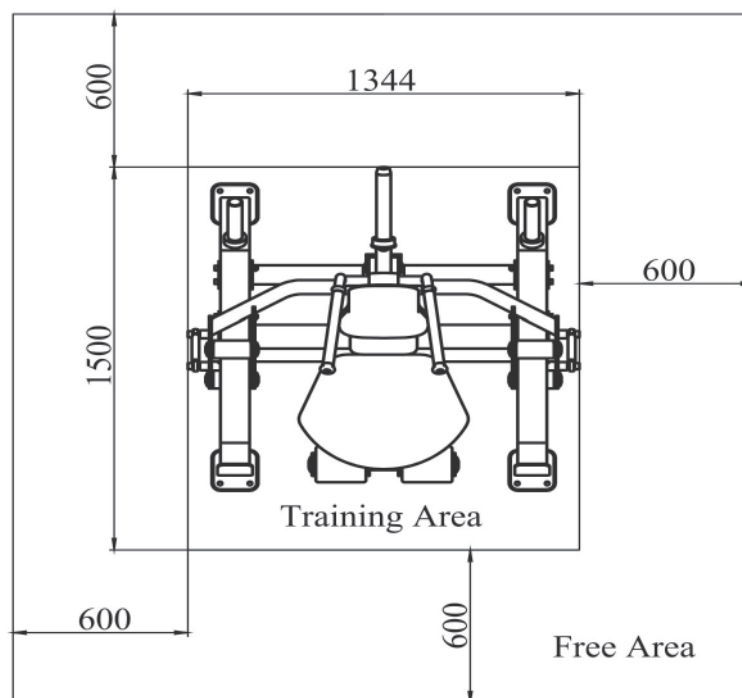

2.1 General Instructions



DANGER

- + Do not leave any tools, packaging materials such as foils or small parts lying around, as otherwise there is a danger of suffocation for children. Keep children away from the equipment during assembly.



WARNING

- + Pay attention to the instructions attached to the equipment in order to reduce the risk of injuries.



CAUTION

- + Ensure to have sufficient room for movement in each direction during assembly.
- + The assembly of the equipment must be carried out by at least two adults. If in doubt, seek the help of a third technically skilled person.



ATTENTION

- + To prevent damage to the equipment and the floor, assemble the equipment on a mat or packaging board.



NOTICE

- + In order to make the assembly as simple as possible, some screws and nuts to be used can already be pre-assembled.
- + Ideally, assemble the equipment at its later set-up place.

2.2 Scope of Delivery

The scope of delivery consist of the following parts. At the beginning, check whether all parts and tools belonging to the device are included in the scope of delivery and whether damage has occurred. In the event of complaints, the contractual partner must be contacted directly.



CAUTION

- If parts of the scope of delivery are missing or damaged, the assembly must not be carried out.

Content of Box 1

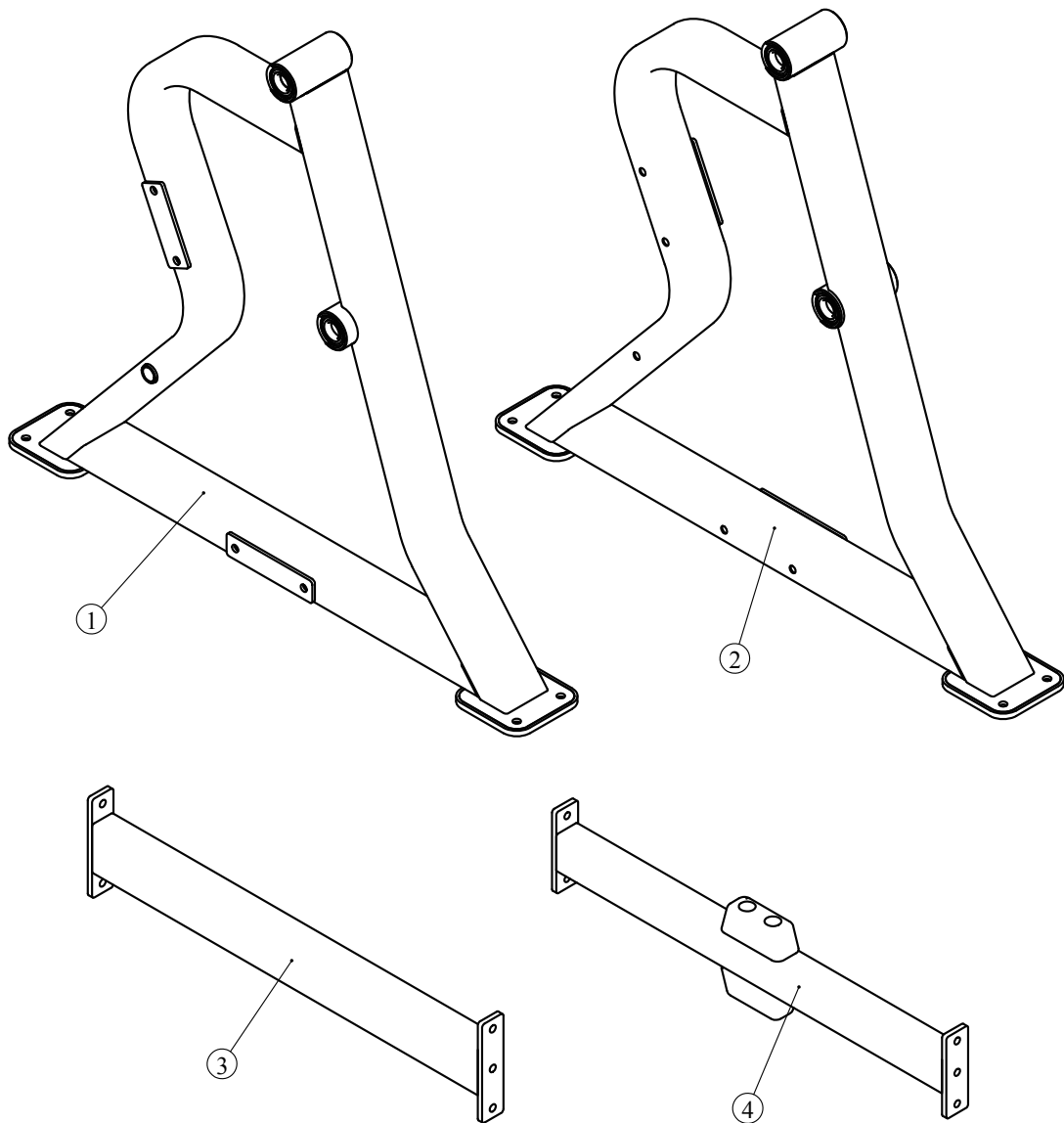

Part no.	Description	Qty.
1	Left Frame ASSY	1
2	Right Frame ASSY	1
3	Base Crossmember	1
4	Rear Crossmember	1

Content of Box 2

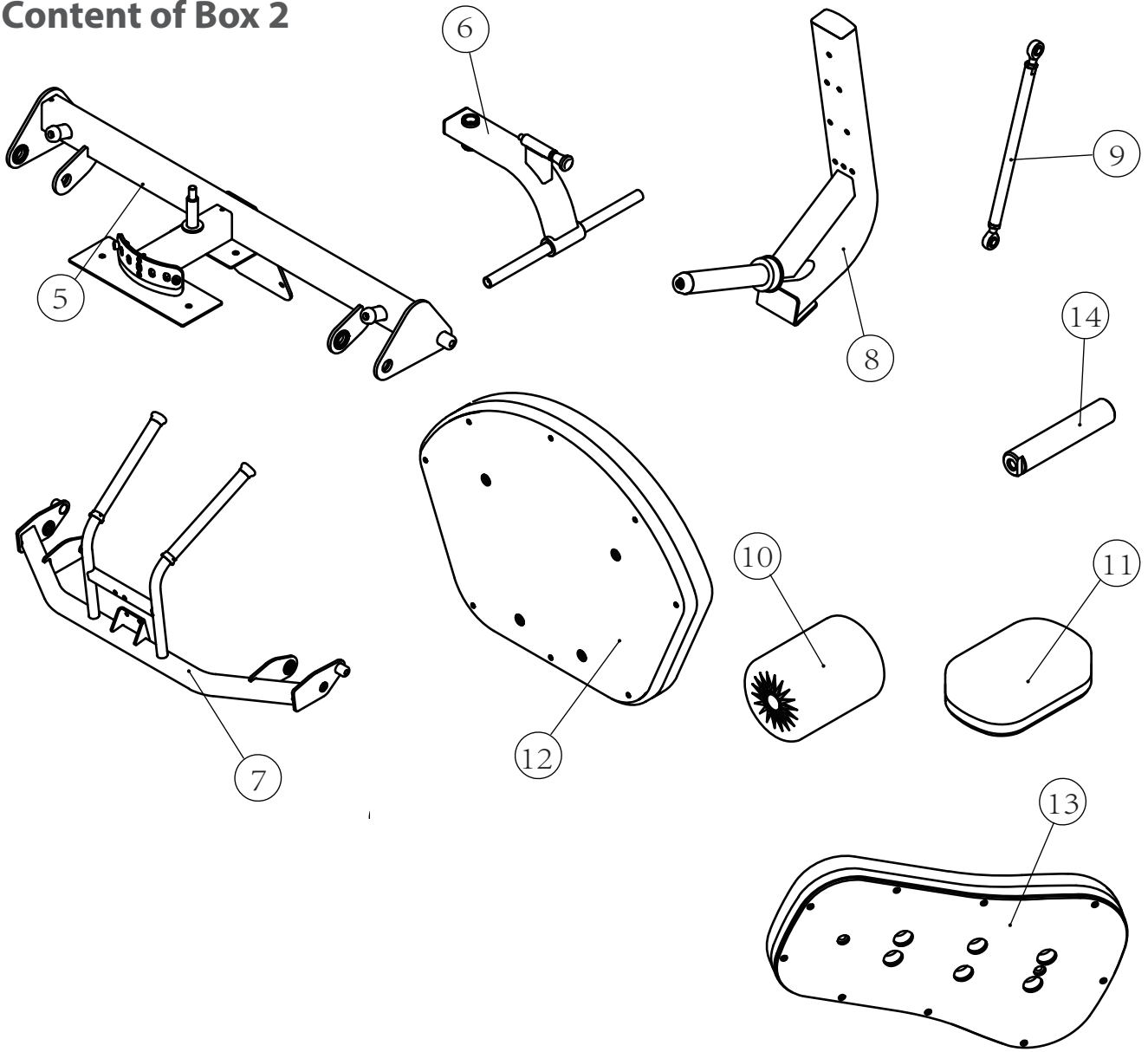

Part no.	Description	Qty.
5	Lower Pivoting ASSY	1
6	Foam Pad Mount ASSY	1
7	Upper Pivoting ASSY	1
8	Back Pad Mount ASSY	1
9	Connecting Rod ASSY	2
10	Foam Pad	2
11	Hip Pad	1
12	Seat Pad	1
13	Back Pad	1
14	Pivot Shaft	4
	Manual	1
	Hardware Pack	1

Manual

Hardware Pack

2.3 Assembly

Before assembly, take a close look at the individual assembly steps shown and carry out the assembly in the order given.

NOTICE

- + First loosely screw all parts together and check that they fit properly. Tighten the screws using the tool only when you are instructed to do so.
- + If you have difficulty recognising the graphics, we recommend that you open and/or download the PDF instructions stored in the webshop on your end device (e.g. smartphone, tablet or PC). There you have the option of zooming in closer.
- + For better readability, the addition "ASSY" to the name of some assembly components has been omitted in the assembly instructions. The abbreviation refers to components that consist of more than one component but have been pre-assembled by factory. Please note that the abbreviation is used in the parts lists and exploded drawings as it may be relevant for ordering spare parts.

Required Tools

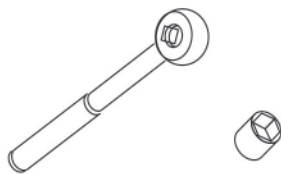

Ratchet Wrench and Socket



Adjustable Wrench

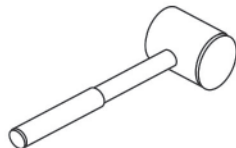

Rubber Mallet



Hex Key Wrench Set

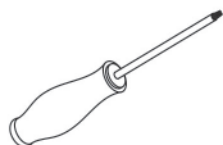

Phillips Screwdriver

Step 1: Assembly of the Left and Right Frames and Crossmembers

NOTICE

Do not tighten the bolts and nuts completely yet.

1. Attach the base crossmember (3) to the left and right frames (1 & 2) with a total of four bolts (20), eight flat washers (27) and four lock nuts (31).
2. Attach the rear crossmember (4) to the left and right frames (1 & 2) with a total of four bolts (20), eight flat washers (27) and four lock nuts (31).

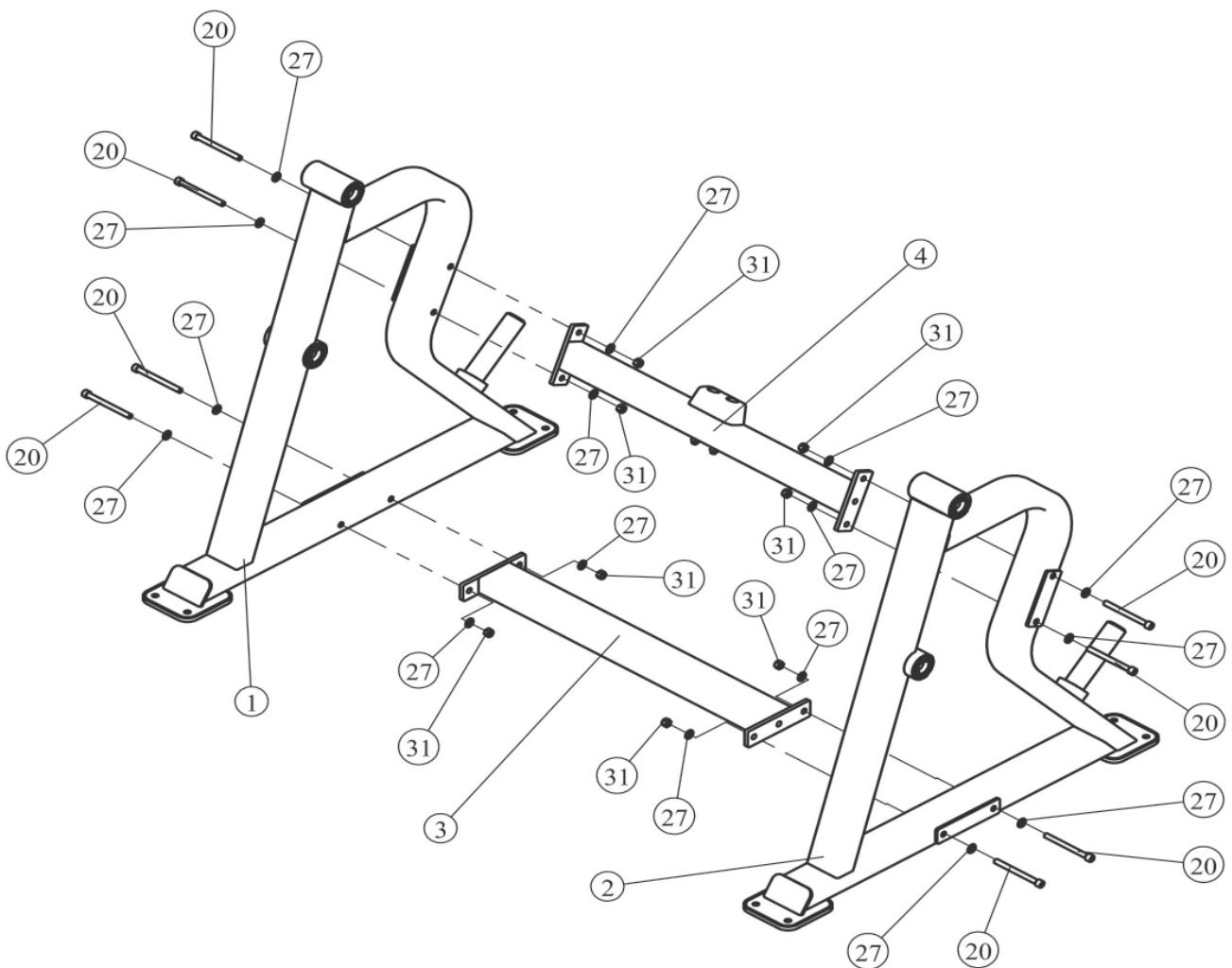

Step 2: Assembly of th Lower and Upper Pivoting

ⓘ NOTICE

Do not tighten the bolts and nuts completely yet.

1. Attach the lower pivoting (5) to the left and right frames (1 & 2) with two pivot shafts (14), four aluminium end caps (16) and four screws (24).
2. Attach the upper pivoting (7) to the left and right frames (1 & 2) with two pivot shafts (14), four aluminium end caps (16) and four screws (24).

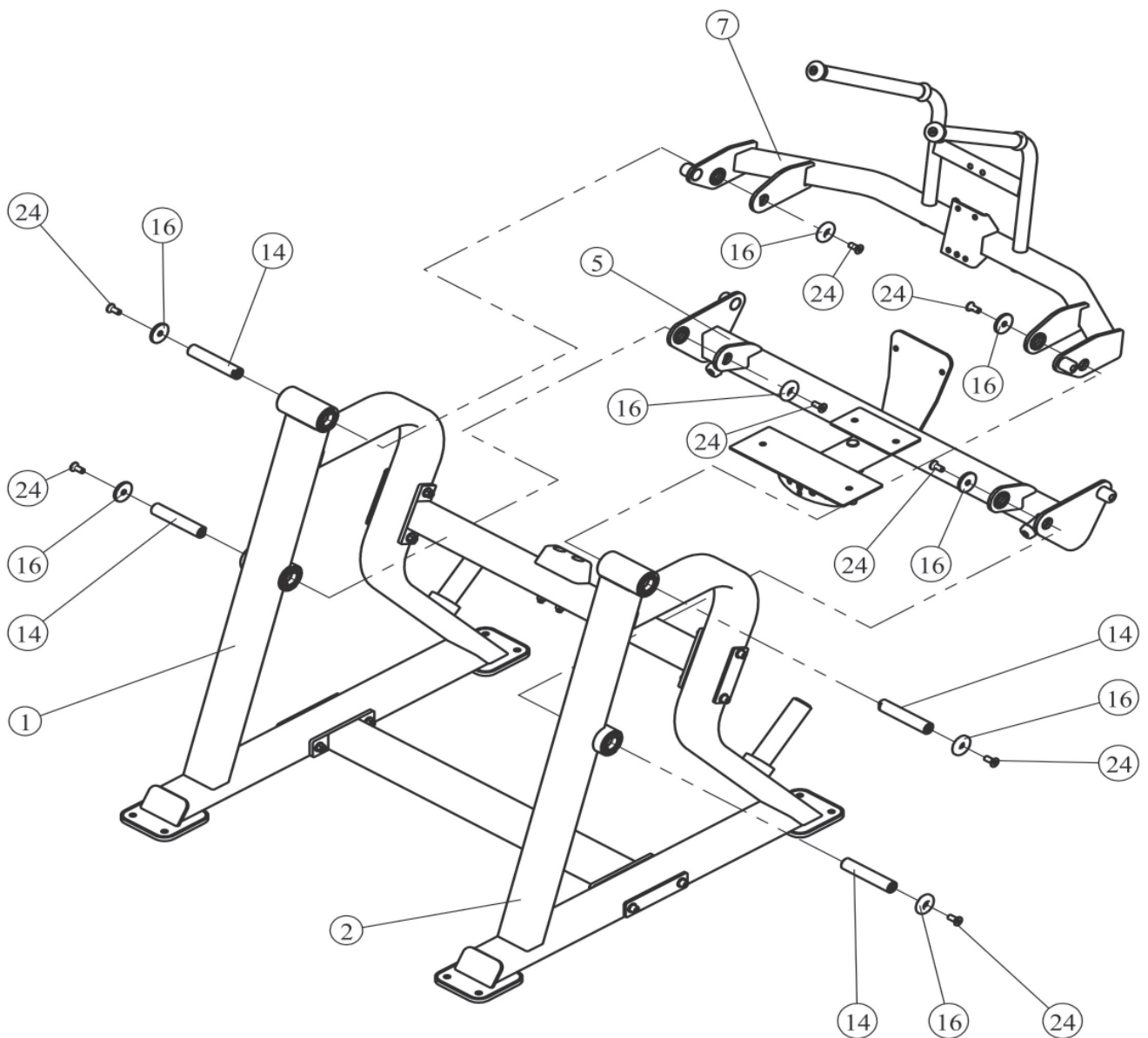

Step 3: Assembly of the Connecting Rods

1. Attach two connecting rods (9) to the lower and upper pivoting (5 & 7) with a total of four screws (19) and four spring washers (26).
2. Tighten the screws with the appropriate tool.
3. Tighten the bolts and nuts from the previous steps with the appropriate tools.

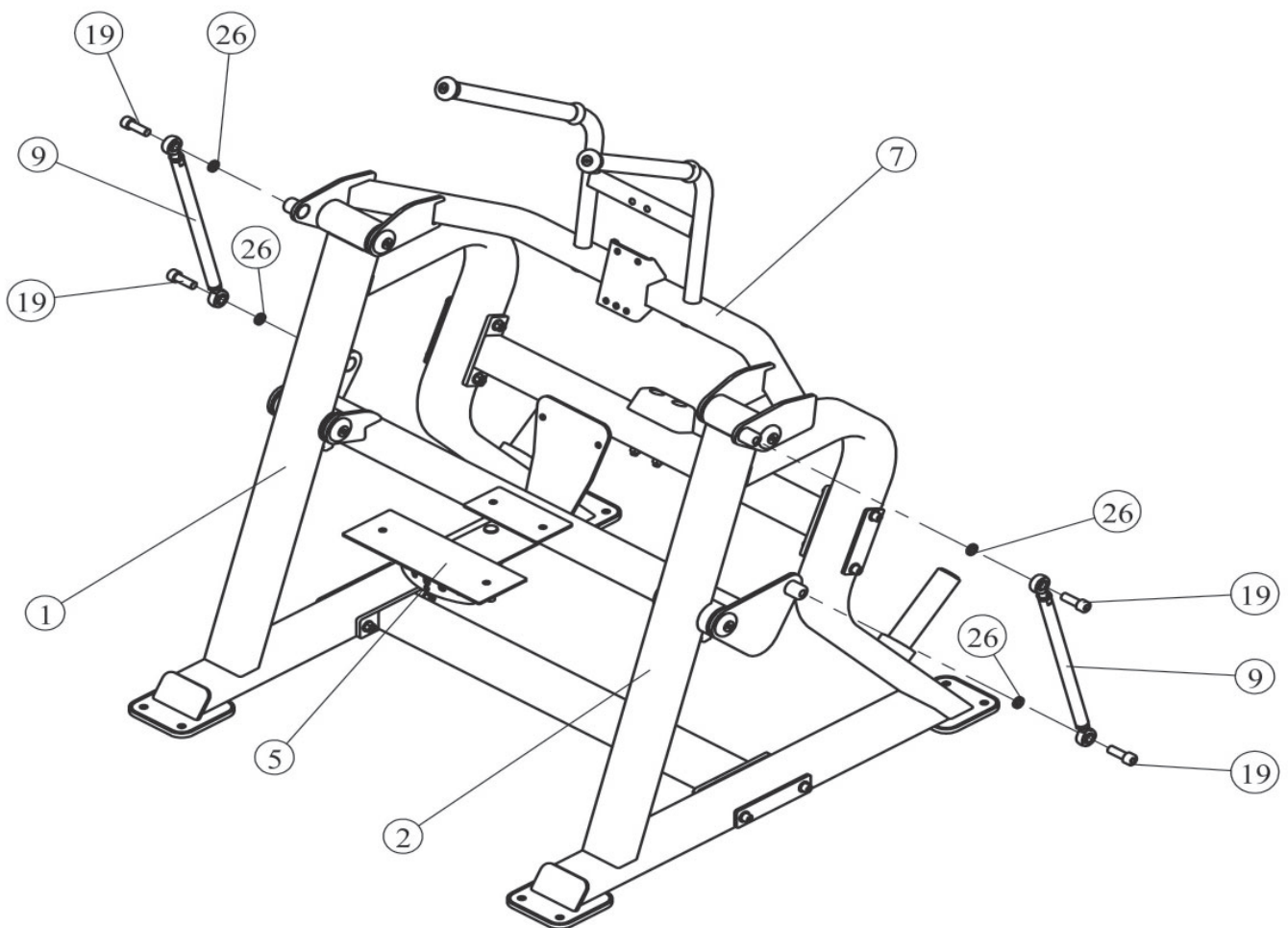

Step 4: Assembly of the Foam Pad Mount and Back Pad Mount

► ATTENTION

Make sure that the foam pad mount (6) can turn smoothly. If needed, adjust the hex nut (29) and lock nut (30).

1. Attach the foam pad mount (6) to the lower pivoting (5) with one flat washer (18), one hex nut (29) and one lock nut (30).
2. Attach the back pad mount (8) to the upper pivoting (7) with two screws (21) [upper holes], four screws (22) [lower holes], twelve flat washers (28) and six lock nuts (32).
3. Tighten the screws and nuts with the appropriate tools.

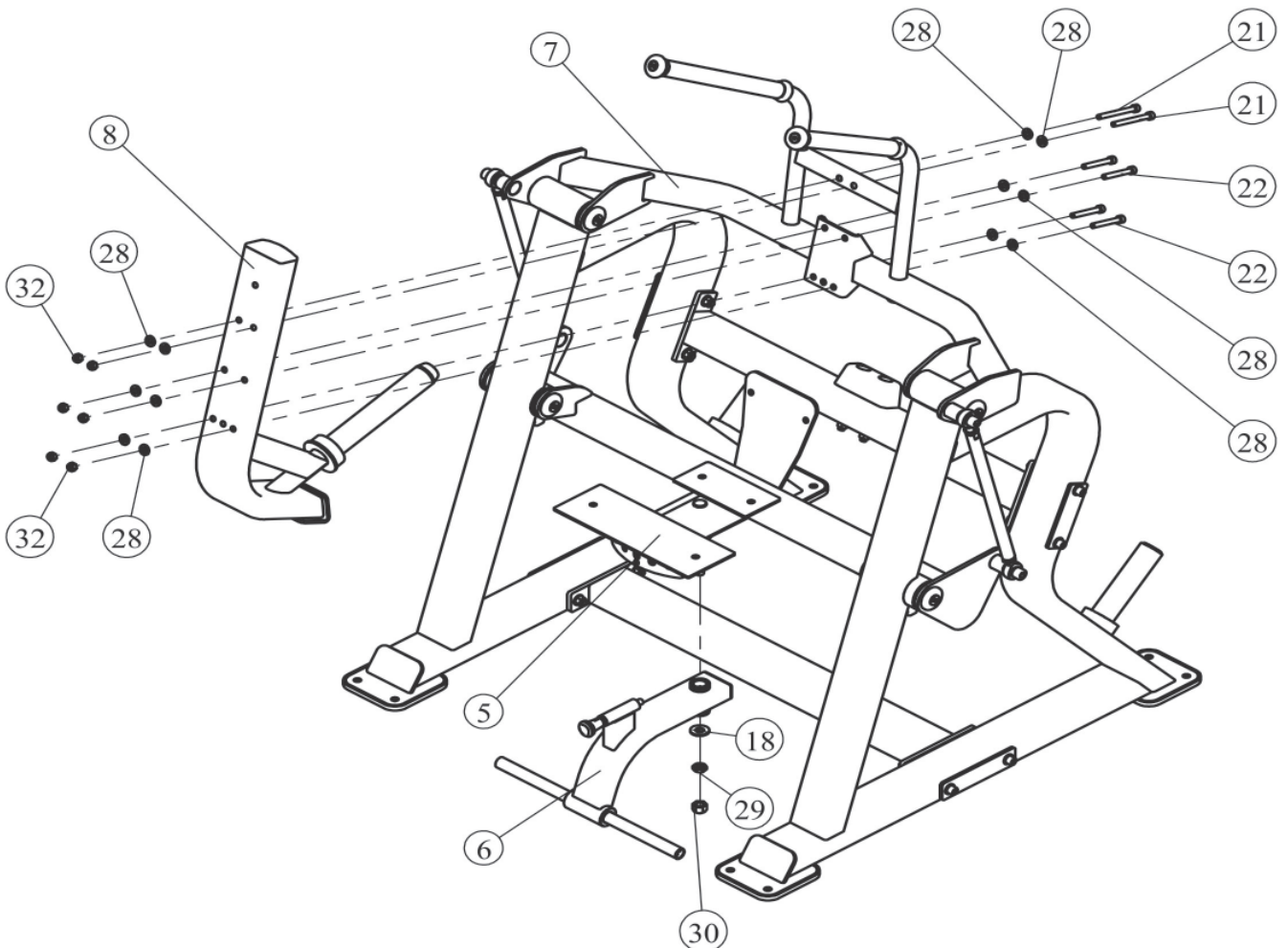

Step 5: Assembly of the Pads

1. Attach two foam pads (10) to the foam pad mount (6) with two end caps (15), one aluminium end cap (17) and one screw (25) each.
2. Attach the seat pad (12) to the lower pivoting (5) with four screws (23) and four flat washers (28).
3. Attach the hip pad (11) to the lower pivoting (5) with two screws (23) and two flat washers (28).
4. Attach the back pad (13) to the back pad mount (8) with two screws (22) and two flat washers (28).
5. Check that all bolts, screws and nuts are properly tightened and retighten if needed.

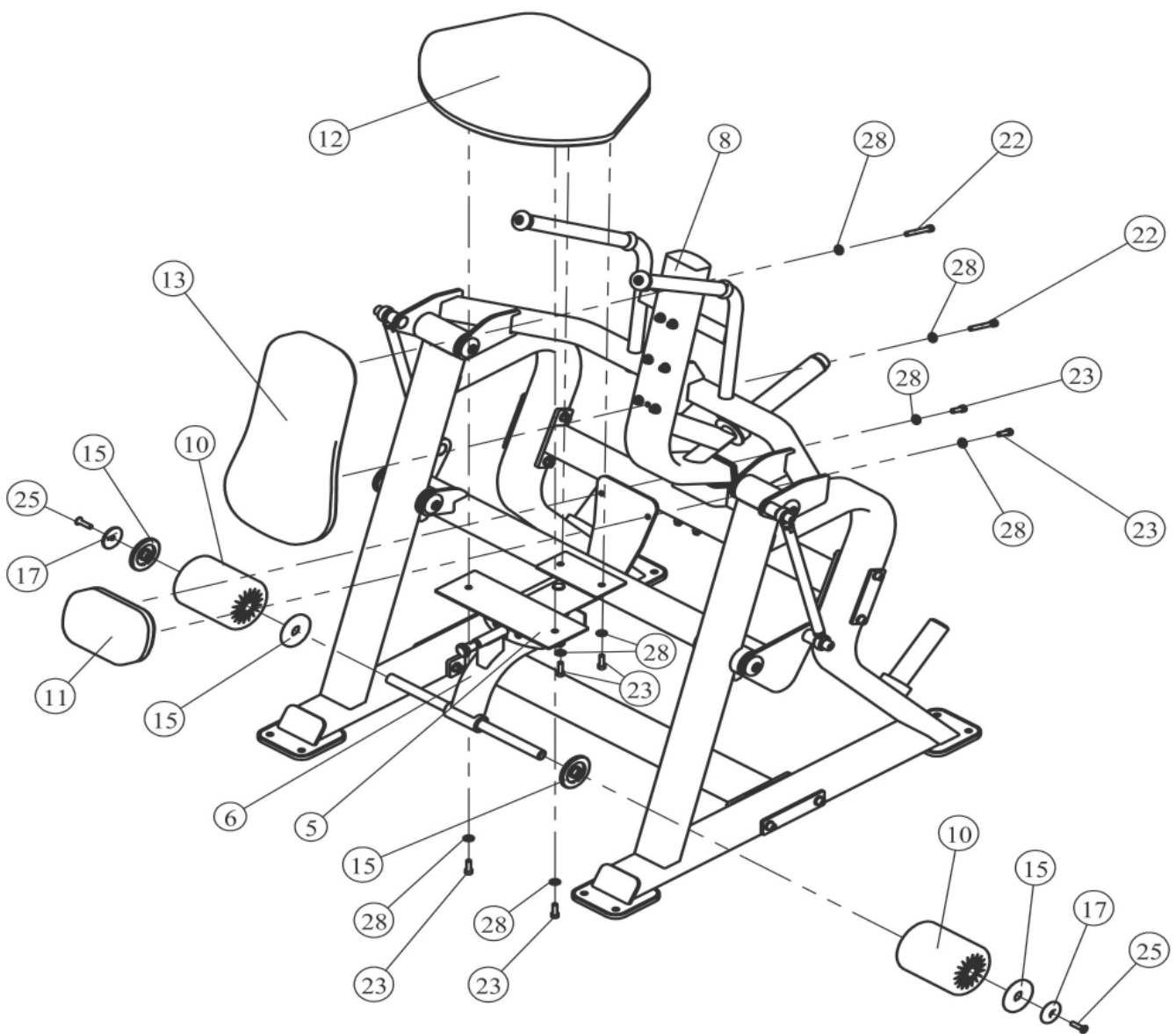

Step 6: Anchoring the Equipment to the Floor (OPTIONAL)

To prevent movement and increase the stability, the equipment can be anchored to the floor. This step is not mandatory. Required tools, bolts and dowels are not included in the scope of delivery.

► **ATTENTION**

- + Not every type of flooring is suitable for anchoring.
 - + Consider the condition of your floor to determine which assembly material is suitable.
 - + Make sure there are no pipes, cables or wires running in the floor where you anchor the equipment.
 - + A hand drill is required to anchor the equipment. Make sure to use suitable drilling attachment. The contractor can not be held liable for any damages to the floor.
1. Drill a total of eight holes in the floor with a hand drill.
 2. Insert suitable dowels into the holes.
 3. Attach the equipment to the floor with suitable bolts.

→ *The assembly is completed.*

Load and Unload Weight Plates

► ATTENTION

- + Make sure to always use some sort of weight collar when exercising with external weights.
- + Store unused weight plates on a weight rack or on the integrated storage option.

ⓘ NOTICE

- + Use weight plates with a 50 mm hole and an external diameter of not larger than 450 mm.
 - + Weight plates and weight collars are not included in the scope of delivery.
 - + Do not load more than 120 kg to the weight horn (training weight).
 - + Do not load more than 100 kg to each weight horn (storage).
1. To load the weight horn, carefully grab one weight plate at a time with both hands.
 2. Slide each weight plate onto the weight horn one by one until you have reached your desired training weight.
 3. Attach a weight collar to secure the weight plates from sliding off.
 4. To unload the weight horn, first take off the weight collar.
 5. Carefully slide each weight plate off of the weight horn with both hands one by one.

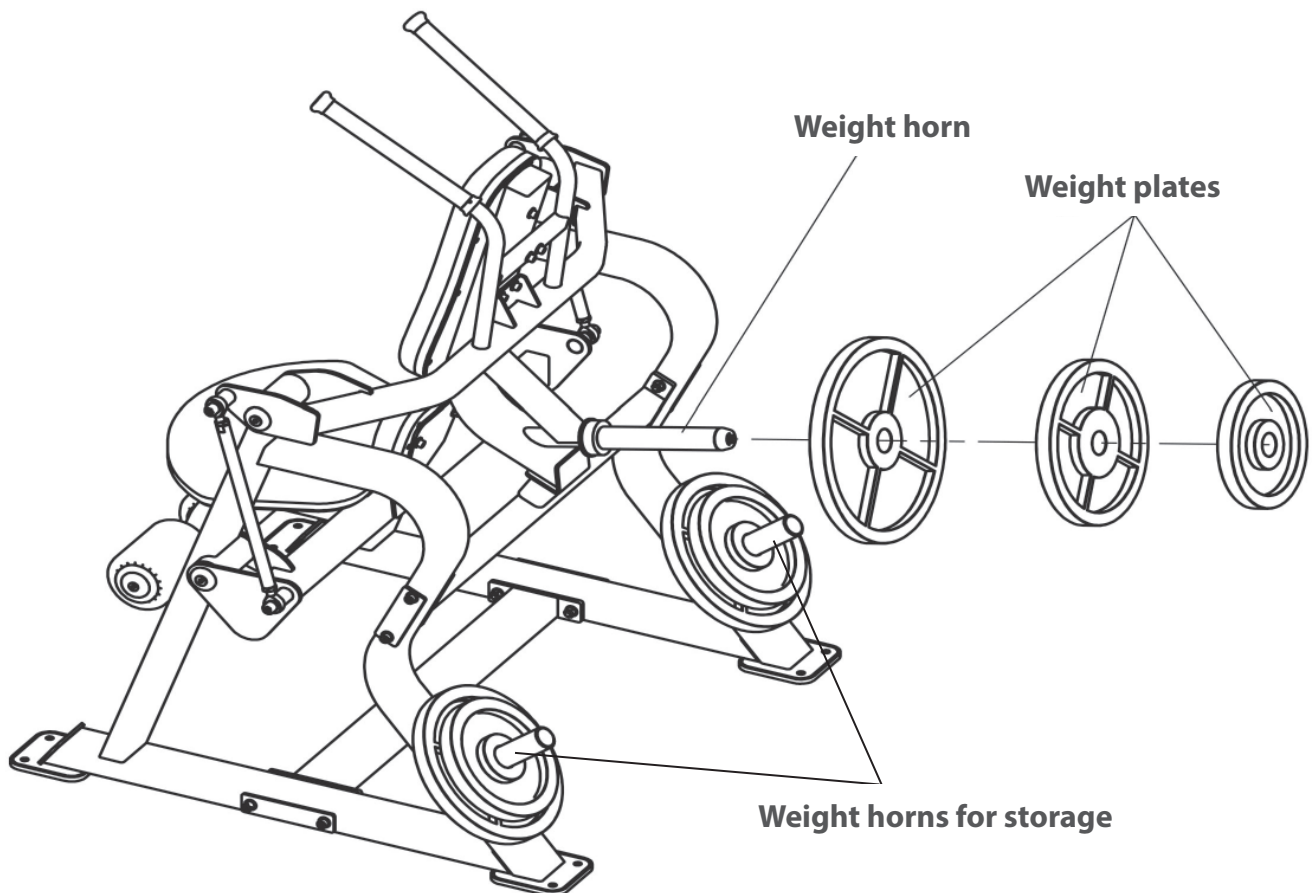

Seat Pad Adjustment

The seat can be adjusted in different positions depending on if you want to train your straight or lateral abdominal muscles.

1. Pull the spring pin and adjust the seat in the desired position.
2. Release the spring pin and make sure it fully engages in one of the adjustment holes.

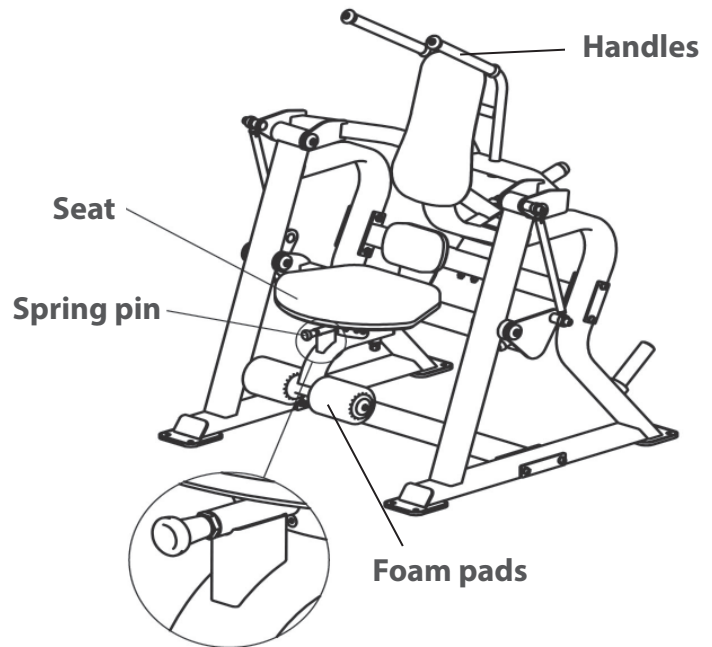

Exercise Instructions

1. Select an appropriate weight.
2. Sit down on the seat with your back against the back pad.
3. Place your feet behind the foam pads and grasp the handles with both hands.
4. Pull the handles down while pulling the foam pads up.
5. Slowly return to the starting position.

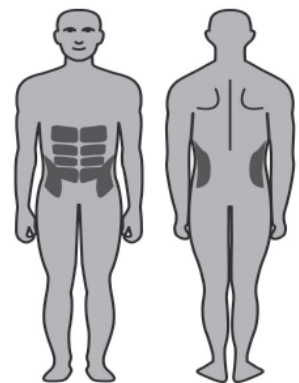
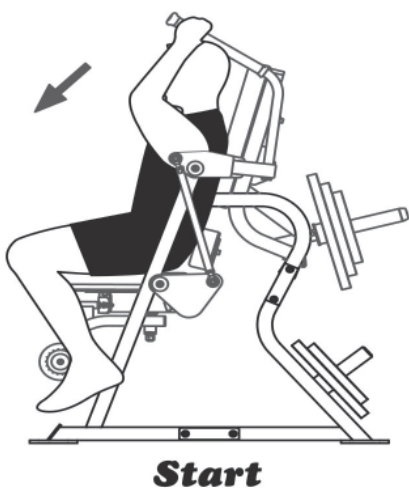

3.1 General Instructions



WARNING

- + The storage location should be chosen so that improper use by third parties or children can be prevented.
- + If your equipment does not have transportation wheels, the equipment must be disassembled before transportation.



ATTENTION

- + Make sure that the equipment is protected from moisture, dust and dirt in the selected storage location. The storage location should be dry and well ventilated and have a constant ambient temperature between 10°C and 35°C.

4.1 General Instructions



WARNING

- + Do not make any improper changes to the equipment.



CAUTION

- + Damaged or worn components may affect your safety and the life of the equipment. Safety can only be guaranteed if you check the equipment regularly for wear and damage. Replace damaged or worn components immediately. In such a case, contact the contract partner. The equipment must not be used until it has been repaired. If necessary, use only original spare parts.



ATTENTION

- + In addition to the instructions and recommendations for maintenance and care given here, additional service and/or repair work may be necessary; this must only be carried out by authorised service technicians.

4.2 Faults and Fault Diagnosis

The equipment undergoes regular quality controls during production. Nevertheless, faults or malfunctions may occur. Frequently, individual parts are responsible for these disturbances, an exchange is usually sufficient. Please refer to the following overview for the most common errors and how to correct them. If the equipment still does not function properly, contact your contract partner.

Fault	Cause	Solution
Squeaking & cracking noises	Screw connections loosened or too tight	+ Check or lubricate screw connections*
Unit wobbles	+ Uneven ground	+ Align unit
	+ Loose screw connections	+ Tighten screw connections

* With a grease-free silicone oil or silicone spray.

4.3 Maintenance and Inspection Calendar

To avoid damage from body sweat, the equipment must be cleaned with a damp towel (no solvents!) after each training session.

The following routine tasks must be performed at the specified intervals:

Part	Weekly	Monthly	Quarterly
Screw connections		I	
Cushions	C		
Legend: C = clean; I = inspect			

5 DISPOSAL

At the end of its operational life, this equipment cannot be disposed of in normal household waste. Instead, it must be disposed of via an recycling centre. Further information can be obtained from your local authority's recycling service.



The materials can be recycled as per their symbols. Through the reuse, recycling of materials or other forms of recovery of old equipment, you make an important contribution to the protection of the environment.

6 RECOMMENDED ACCESSORIES

To make your training experience even more efficient and pleasant, we recommend that you add suiting accessories to your fitness equipment. For training equipment like smith machines, weight benches or racks this could for example be a **floor mat**, which makes your fitness equipment stand more securely and also protects the floor from sweat but it could be also **additional weights, handles, foot straps** for leg exercises or **triceps ropes**. For some smith machines, there are also optional add-ons such as **leg presses** that make your workout even more intense and comprehensive.

Our range of accessories offers the highest quality and makes training even better. If you would like to find out more about compatible accessories, please go to the detail page of the product in our webshop (the easiest way is to enter the article number in the search field above) and go to the recommended accessories on this page. Alternatively, you can scan the QR code provided. Of course, you can also contact our customer service: by telephone, e-mail, in one of our branches or via our social media channels. We will be happy to advise you!



floor mat



chest strap



triceps rope



weight block extension

7.1 Serial Number and Model Name

In order to provide you with the best possible service, please have the model name, article number, serial number, exploded drawing and parts list ready. The corresponding contact options can be found in chapter 10 of this operating manual.

NOTICE

The serial number of your equipment is unique. It's located on a white sticker.

Enter the serial number in the appropriate field.

Serial number:

Brand / Category:

Model Name:

Article Number:

7.2 Parts List

Overall

Grade no.	Supplier parts no.	Name	Qty.
1	SL7036B01ASSY	Left Frame ASSY	1
2	SL7036B02ASSY	Right Frame ASSY	1
3	SL70360300	Base Crossmember	1
4	SL7036B04ASSY	Rear Crossmember ASSY	1
5	SL7036B05ASSY	Lower Pivoting ASSY	1
6	SL7036B06ASSY	Foam Pad Mount ASSY	1
7	SL7036B07ASSY	Upper Pivoting ASSY	1
8	SL703608ASSY	Back Pad Mount ASSY	1
9	ABS100409ASSY	Connecting Rod ASSY	2
10	SL70021900V1	Foam Pad	2
11	SL70170800	Hip Pad	1
12	SL7036B1300	Seat Pad	1
13	SL70361500	Back Pad	1
14	SL70361600	Pivot Shaft	4
15	IT70165000	End Cap $\Phi 90 \times \Phi 26.2 \times 8.5$	4
16	SL70011700	Aluminum End Cap $\Phi 54 \times \Phi 12.5 \times 10.6$	8
17	IT90041700	Aluminum End Cap $\Phi 60 \times \Phi 10.5 \times 10.9$	2
18	ABS10011500	Flat Washer $\Phi 37 \times \Phi 17 \times 3$	1
19	GB70M16*45DS20	Socket Head Cap Screw M16*45	4
20	GB70M12*135DHS20	Socket Head Cap Screw M12*135	8
21	GB70M10*100DHS20	Socket Head Cap Screw M10*100	2
22	GB70M10*75DHS20	Socket Head Cap Screw M10*75	6
23	GB70M10*30DHS20	Socket Head Cap Screw M10*30	6
24	CNLM12*30DS 20NL	Flat Head Cap Screw M12*30	8
25	CNLM10*40*40DS20NL	Flat Head Cap Screw M10*40	2
26	GB9316DS12	Spring Washer $\Phi 16$	4
27	DQ12DHS2A	Flat Washer $\Phi 13 \times \Phi 24 \times 1.5$	16
28	DQ10DHS2A	Flat Washer $\Phi 11 \times \Phi 23 \times 2$	20
29	GB6172.1M16DS2	Hex Nut M16*8	1
30	NM16DS2	Nylon Lock Nut M16	1

31	NM12DHS2	Nylon Lock Nut M12	8
32	NM10DHS2	Nylon Lock Nut M10	6
33	NBS12DHS	Hex Key S=12	1
34	NBS10DHS	Hex Key S=10	1
35	NBS8DHS	Hex Key S=8	1
36	NBS6DHS	Hex Key S=6	1

Left Frame ASSY (1)

Grade no.	Supplier parts no.	Name	Qty.
1.1	SL7036B0100	Left Frame	1
1.2	GB2 766006-2ZC3	Deep Groove Ball Bearing $\Phi 30 \times \Phi 55 \times 13$	4
1.3	CWRVL00S 1200	Rubber Foot	2
1.4	HF985A1500	Rubber Bumper	1
1.5	BGI 714700	Weight Horn Sleeve	1
1.6	HF985A1700	End Plug	1

Right Frame ASSY (2)

Grade no.	Supplier parts no.	Name	Qty.
2.1	SL7036B0200	Right Frame	1
2.2	GB2 766006-2ZC3	Deep Groove Ball Bearing $\Phi 30 \times \Phi 55 \times 13$	4
2.3	CWRVL00S 1200	Rubber Foot	2
2.4	HF985A1500	Rubber Bumper	1
2.5	BGI 714700	Weight Horn Sleeve	1
2.6	HF985A1700	End Plug	1

Rear Crossmember ASSY (4)

Grade no.	Supplier parts no.	Name	Qty.
4.1	SL70360400	Rear Crossmember	1
4.2	PL380800	Large Rubber Bumper	1
4.3	GB70MI 2*120DHS20	Socket Head Cap Screw M12*120	2
4.4	DQ12DHS2A	Flat Washer $\Phi 13 \times \Phi 24 \times 1.5$	4
4.5	NM12DHS2	Nylon Lock Nut M12	2

Lower Pivoting ASSY (5)

Grade no.	Supplier parts no.	Name	Qty.
5.1	SL7036B0500	Lower Pivoting	1
5.2	SL7036B1800	Are Plate	1
5.3	PS10007100	Bumper	2
5.4	C001PL3800	Spacer Bush	4
5.5	IN-S10111200	Spacer Φ 17*10.5	2
5.6	GB70M8*25DS20	Socket Head Cap Screw M8*25	2
5.7	PNLM6*15DHS20	Button Head Cap Screw M 16*15	2
5.8	CNLM6* 15DS20NL	Flat Head Cap Screw M16*15	2
5.9	GB958DS2	Flat Washer Φ 9* Φ 16*1.6	2
5.10	NM8DS2	Nylon Lock Nut MB	2

Foam Pad Mount ASSY (6)

Grade no.	Supplier parts no.	Name	Qty.
6.1	SL7036B0600	Foam Pad Mount	1
6.2	IT9315G1500	Spring Pin	1
6.3	M02502000	Bushing	2
6.4	CF37543400	Pipe Plug 38.1 *76.2	1
6.5	IF81165000	Nut M1 0	2

Upper Pivoting ASSY (7)

Grade no.	Supplier parts no.	Name	Qty.
7.1	SL7036B0700	Upper Pivoting	1
7.2	IF81212700	Nut M10	2
7.3	IT90122100	Aluminium Grip Ring	2
7.4	HV3PA2000	Grip	2
7.5	IT90122000	Aluminium Grip Cap	2
7.6	CNLM10*30* 30N19NL	Flat Head Cap Screw M10*30	2
7.7	YZGB7710-32*3.2NI 9	Socket Set Screw 10-32*3.2	4
7.8	BNH0573	Pipe Plug Φ 32	2
7.9	C001PL3800	Spacer bush	4

Back Pad Mount ASSY (8)

Grade no.	Supplier parts no.	Name	Qty.
8.1	SL70360800	Back Pad Mount	1
8.2	VLP8000	Pipe Plug 50*100	1
8.3	HF985A1500	Rubber Bumper	1
8.4	TPS3901500	Lang Weight Horn Sleeve	1
8.5	SL70012000	Weight Horn PlasticCap	1
8.6	DQ12DHS2A	Flat Washer Φ 13* Φ 24*1.5	1
8.7	GB70MI 2*35*35DHS20NL	Socket Head Cap Screw M12*35	1

Connecting Rod ASSY (9)

Grade no.	Supplier parts no.	Name	Qty.
9.1	ABS10040900	Connecting Rod	1
9.2	SABJK16C	TieRod End M16* Φ 16	1
9.3	SABJK16CL	TieRod End M16* Φ 16(Left)	1
9.4	GB6172.1MI 6OS2	Hex Nut M16*8	1
9.5	GB6172.1LM16DS2	Hex Nut M16*8(Left)	1

7.3 Exploded Drawing

Overall

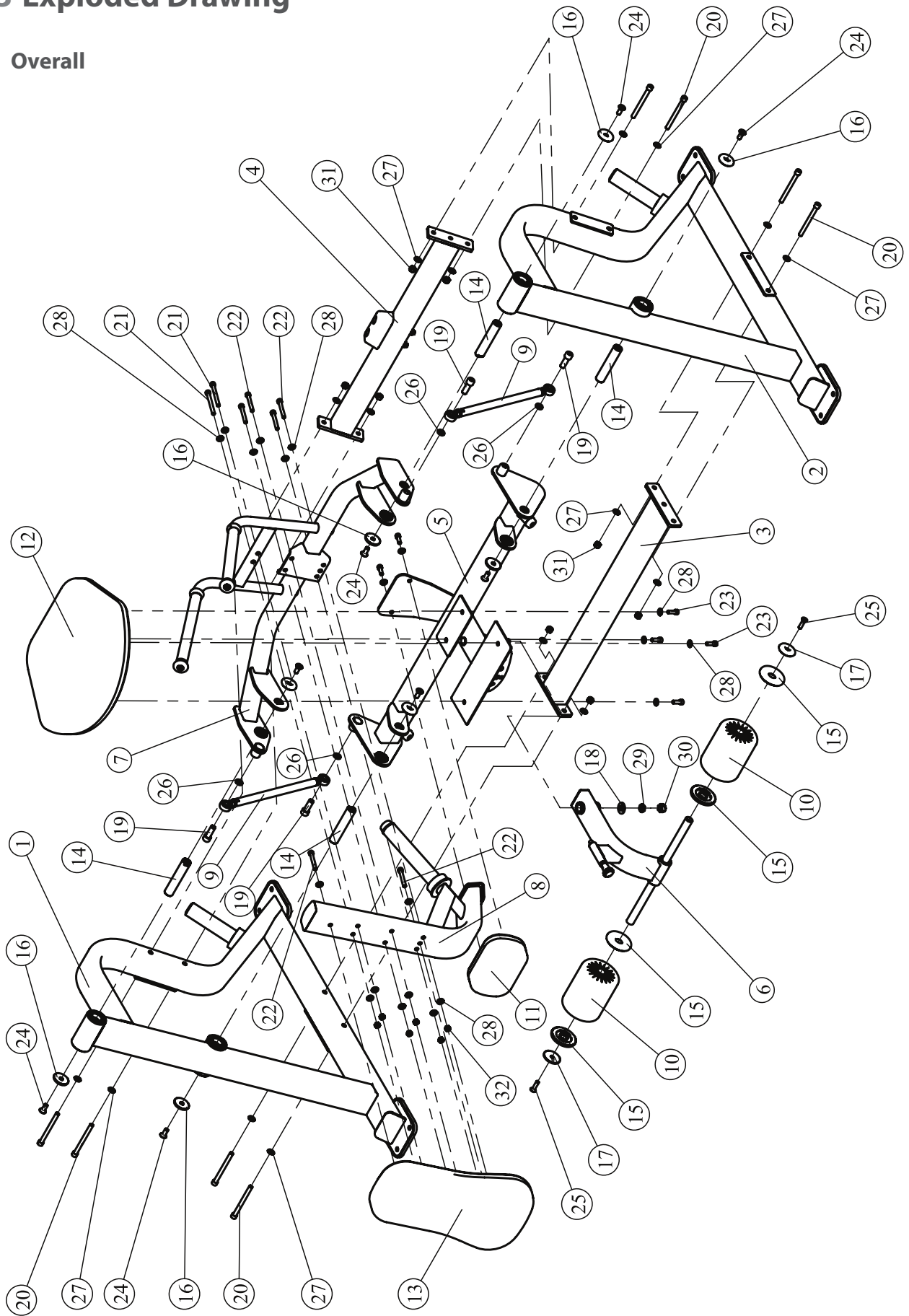

Left Frame ASSY (1)

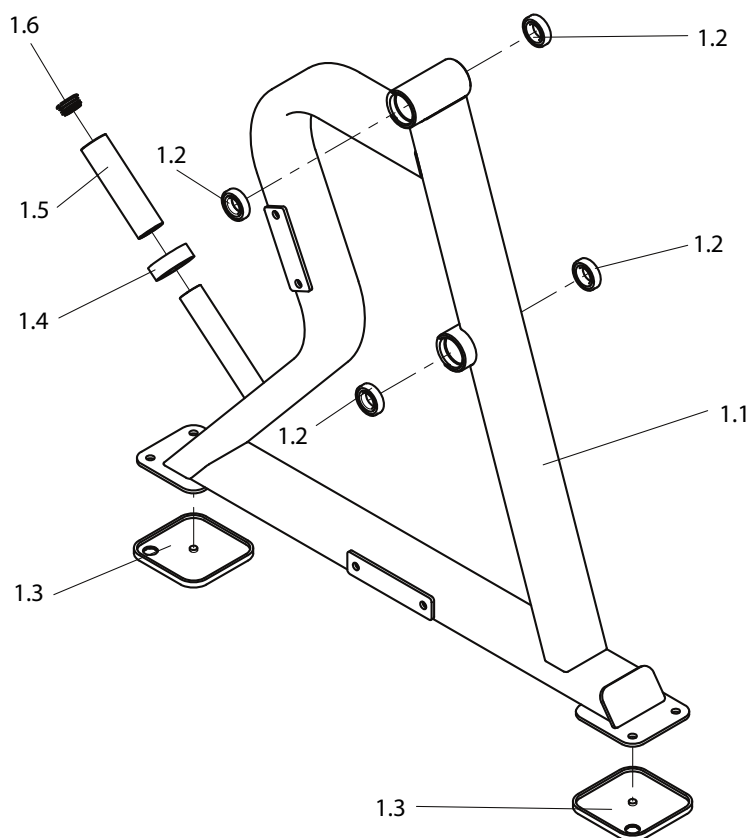

Right Frame ASSY (2)

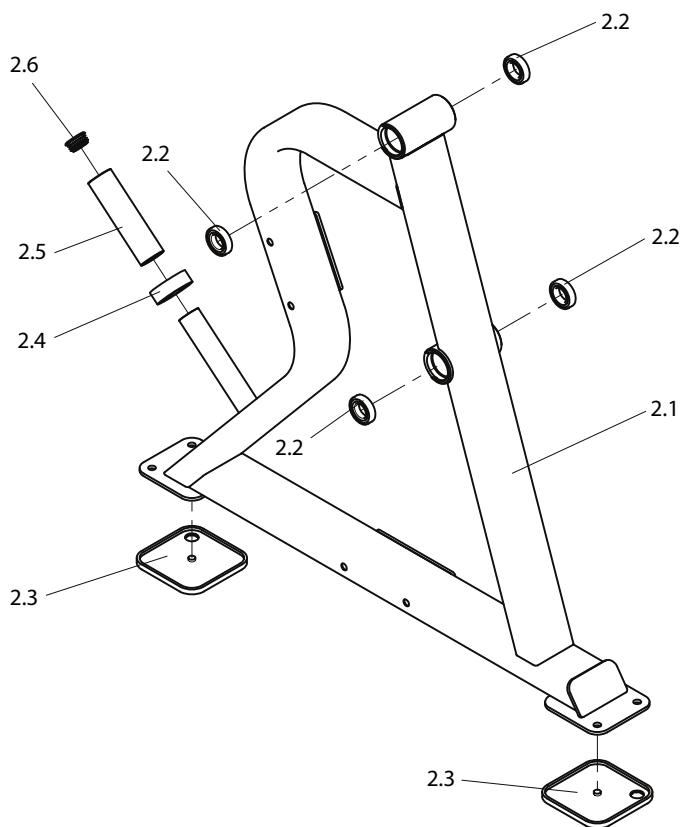

Rear Crossmember ASSY (4)

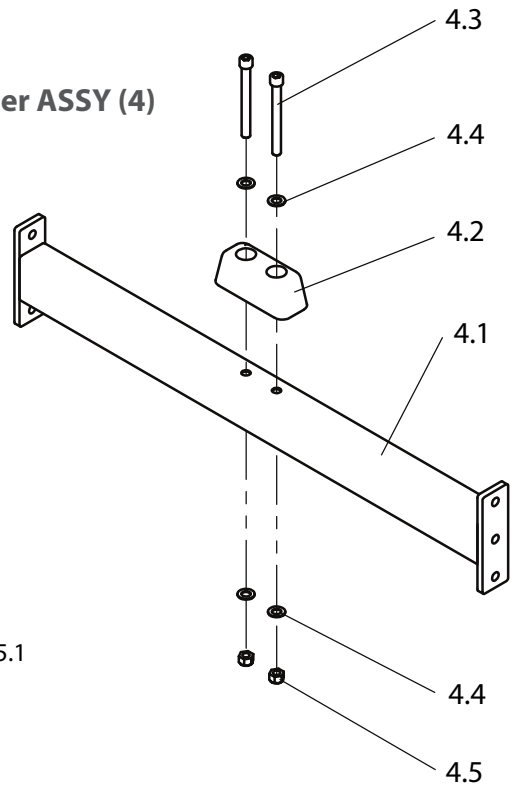

Lower Pivoting ASSY (5)

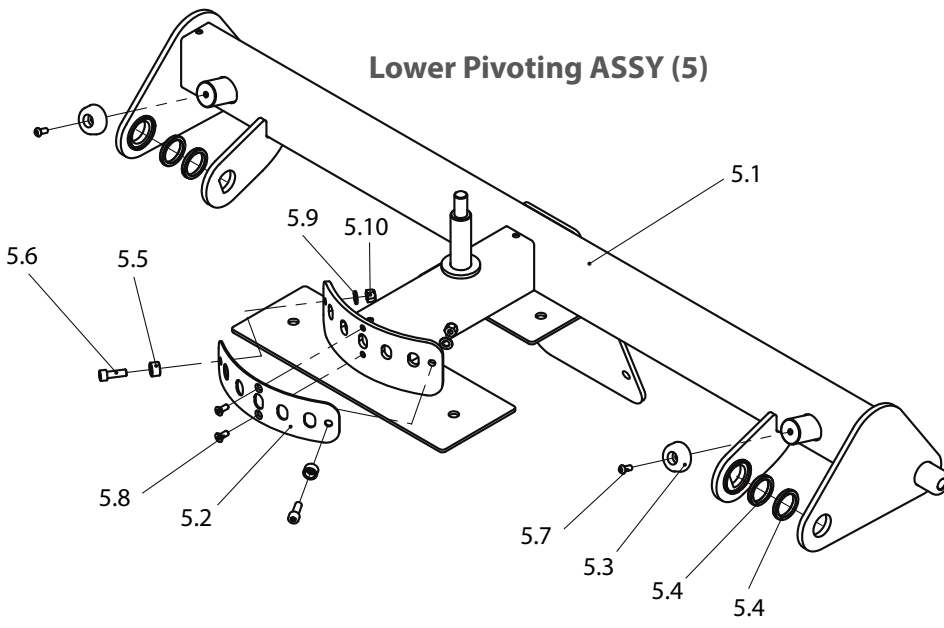

Foam Pad Mount ASSY (6)

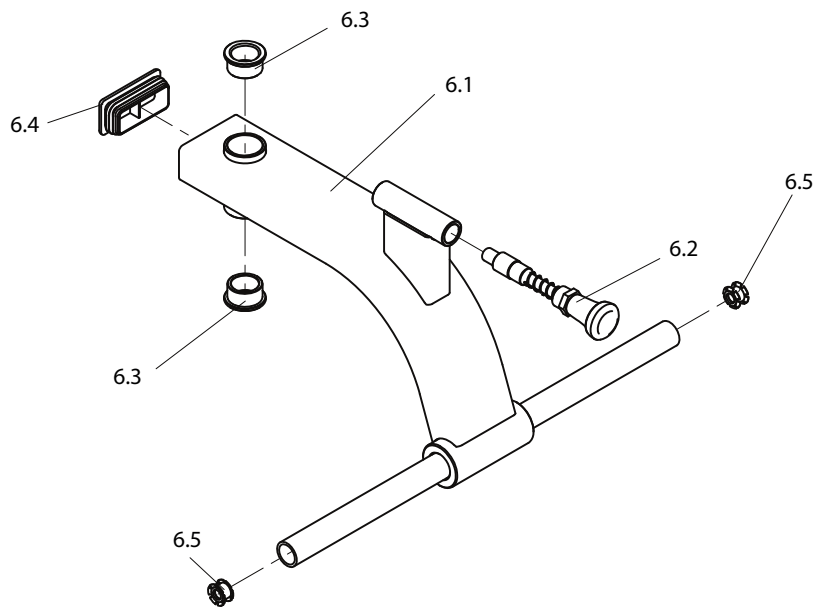

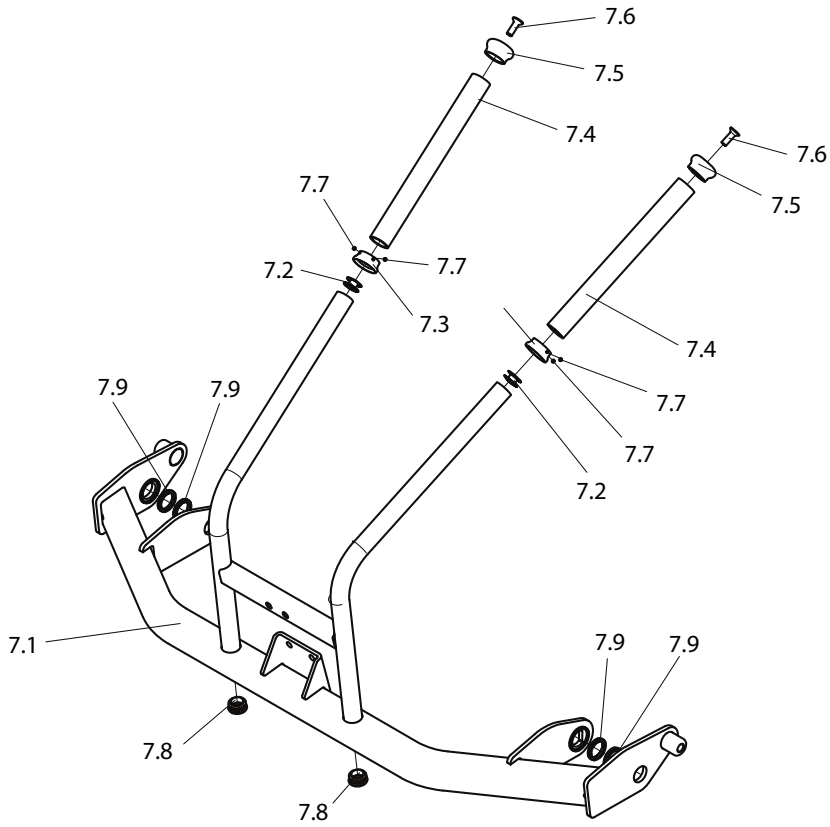

Upper Pivoting ASSY (7)

Back Pad Mount ASSY (8)

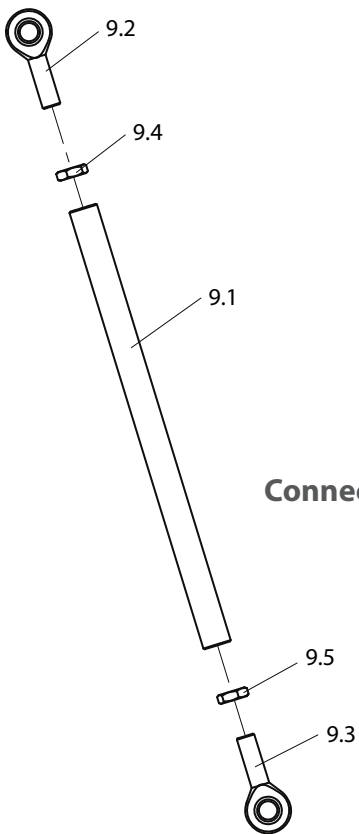
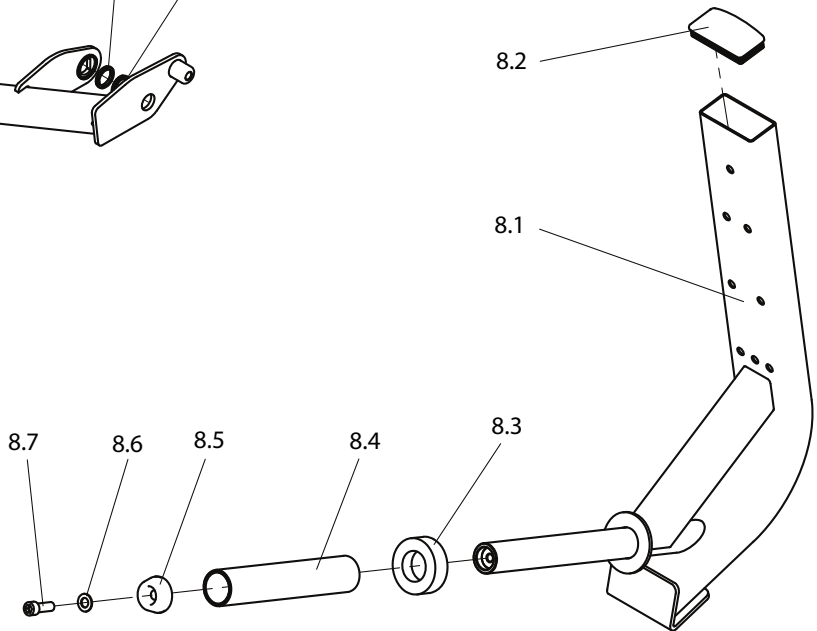

Connecting Rod ASSY (9)

Training equipment from Taurus® is subject to strict quality control. However, if a fitness equipment purchased from us does not work perfectly, we take it very seriously and ask you to contact our customer service as indicated. We are happy to help you by phone via our service hotline.

Error Descriptions

Your fitness equipment is developed for long-term, high-quality training. However, should a problem arise, please first read the operating instructions. For further assistance, please contact your contract partner or call our service hotline. To ensure your problem is solved as quickly as possible, please describe the defect as exactly as possible.

In addition to the statutory warranty, we provide a warranty for every fitness equipment purchased from us according to the following provisions.

Your statutory rights are not affected.

Warrantee

The warrantee is the first/original buyer and/or any person who received a newly purchased product as a gift from the original buyer.

Warranty period

The warranty periods, shown on our web shop, begin on delivery of the fitness equipment. The respective warranty periods for your equipment can be found on its product website.

Repair Costs

According to our choice, there will either be a repair, a replacement of individual damaged parts or a complete replacement. Spare parts, that have to be mounted while assembling the equipment, have to be replaced by the warrantee personally and are not a part of repair. After the expiration of the warranty period, the responsibility for parts costs, repair costs, installation costs and delivery costs lies with the warranty holder.

The terms of use are defined as follows:

- + Home use: solely for private use in private households up to 3 hours per day
- + Semi-professional use: up to 6 hours per day (e. g. rehabilitation centres, hotels, clubs, company gyms)
- + Professional use: more than 6 hours per day (e. g. commercial gyms)

Warranty Service

Within the warranty period, equipment which develops faults as a result of material or manufacturing defects, will be repaired or replaced at our discretion. Ownership of equipment or parts of equipment which have been replaced is transferred to us. The warranty period is not extended nor does a new warranty period begin following repair or replacement under the warranty.

Warranty Conditions

For the warranty to be valid, the following steps must be taken:

Please contact our customer service by email or phone. If the product under warranty has to be sent in for repair, the seller bears costs. After expiry of the warranty, the buyer bears the costs of transport and insurance. If the fault is covered by our warranty, you will receive a new or repaired equipment in return.

Warranty claims are invalid in case of damage resulting from:

- + misuse or improper handling
- + environmental influences (moisture, heat, electrical surge, dust, etc.)
- + failure to follow the current safety measures for the equipment
- + failure to follow the operating instructions
- + use of force (e. g. hitting, kicking, falling)
- + interventions which were not carried out by one of our authorized service centres
- + unauthorised repair attempts

Proof of Purchase and Serial Number

Please make sure that you are able to provide the appropriate receipt when claiming on your warranty. So that we can clearly identify the model of your equipment, and for the purposes of our quality control, you will need to give the serial number of your equipment, when contacting the service team. Where possible please have your serial number and your customer number ready when you call our service hotline. It will help us to deal with your request swiftly.







































If you cannot find the serial number on your fitness equipment, our service team is at your disposal to offer further information.

Service outside of the Warranty Period

We are also happy to issue an individual cost estimate if there is a problem with your fitness equipment after the warranty has expired, or in cases which do not fall under the terms of the warranty, e. g. normal wear and tear. Please contact our customer service team to find a quick and cost-effective solution to your problem. In such a case you will be responsible for the delivery costs.

Communication

Many problems can be solved just by speaking to us as your specialist supplier. We know how important it is to you as a user of the fitness equipment to have problems solved quickly and simply, so you can enjoy working out with minimal interruption. For that reason, we also want to resolve your queries quickly and in a straightforward manner. Thus, please always keep your customer number and the serial number of the faulty equipment handy.

DE	DK	FR
<p>TECHNIK</p> <p> +49 4621 4210-900</p> <p> +49 4621 4210-698</p> <p> technik@sport-tiedje.de</p> <p> Öffnungszeiten entnehmen Sie unserer Homepage.</p> <p>SERVICE</p> <p> 0800 20 20277 (kostenlos)</p> <p> 04621 4210 - 0</p> <p> info@sport-tiedje.de</p> <p> Öffnungszeiten entnehmen Sie unserer Homepage.</p>	<p>TEKNIK OG SERVICE</p> <p> 80 90 16 50</p> <p>+49 4621 4210-945</p> <p> info@fitshop.dk</p> <p> Åbningstider kan findes på hjemmesiden.</p>	<p>TECHNIQUE & SERVICE</p> <p> +33 (0) 189 530984</p> <p>+49 4621 42 10 933</p> <p> info@fitshop.fr</p> <p> Vous trouverez les heures d'ouverture sur notre site Internet.</p>
	PL	BE
	<p>DZIAŁ TECHNICZNY I SERWIS</p> <p> 22 307 43 21</p> <p>+49 4621 42 10-948</p> <p> info@fitshop.pl</p> <p> Godziny otwarcia można znaleźć na stronie głównej.</p>	<p>TECHNIQUE & SERVICE</p> <p> 02 732 46 77</p> <p>+49 4621 4210 933</p> <p> info@fitshop.be</p> <p> Vous trouverez les heures d'ouverture sur notre site Internet.</p>
UK	NL	INT
<p>CUSTOMER SUPPORT</p> <p> 00800 2020 2772</p> <p>+494621 4210 944</p> <p> info@sport-tiedje.co.uk</p> <p> You can find the opening hours on our homepage.</p>	<p>TECHNISCHE DIENST & SERVICE</p> <p> +31 172 619961</p> <p> service@fitshop.nl</p> <p> De openingstijden vindt u op onze homepage.</p>	<p>TECHNICAL SUPPORT & SERVICE</p> <p> +49 4621 4210-944</p> <p> service-int@sport-tiedje.de</p> <p> You can find the opening hours on our homepage.</p>
ES	AT	CH
<p>TECNOLOGÍA Y SERVICIOS</p> <p> 911 238 029</p> <p> info@fitshop.es</p> <p> Consulta nuestro horario de apertura en la página web.</p>	<p>TECHNIK & SERVICE</p> <p> 0800 20 20277 (Freecall)</p> <p>+49 4621 42 10-0</p> <p> info@sport-tiedje.at</p> <p> Öffnungszeiten entnehmen Sie unserer Homepage.</p>	<p>TECHNIK & SERVICE</p> <p> 0800 202 027</p> <p>+49 4621 42 10-0</p> <p> info@fitshop.ch</p> <p> Öffnungszeiten entnehmen Sie unserer Homepage.</p>

Please find a detailed overview including address and opening hours for all stores of the Sport-Tiedje Group in Germany and abroad on the following website:

www.sport-tiedje.com/en/stores

WE LIVE FITNESS

WEBSHOP AND SOCIAL MEDIA

Sport-Tiedje is Europe's largest specialist store for home fitness equipment with currently over 70 stores and one of the world's most renowned online mail order companies for fitness equipment. Private customers order via the 25 web shops in the respective national language or have their desired equipment assembled on site. In addition, the company supplies fitness studios, hotels, sports clubs, companies and physio practices with professional equipment for endurance and strength training.

Sport-Tiedje offers a wide range of fitness equipment from renowned manufacturers, high-quality in-house developments and comprehensive services, such as a build-up service and sports scientific advice before and after the purchase. The company employs numerous sports scientists, fitness trainers and competitive athletes.

Visit us also on our social media platforms or our blog!



www.sport-tiedje.co.uk
www.sport-tiedje.de/blog



www.facebook.com/SportTiedje



www.instagram.com/sporttiedje



www.youtube.com/user/sporttiedje

TAURUS

 cardiostrong

BODYCRAFT

 cardiojump

 **DUKEFITNESS**

DARWIN

TAURUS[®]

Taurus Iso Abdominal Sterling