

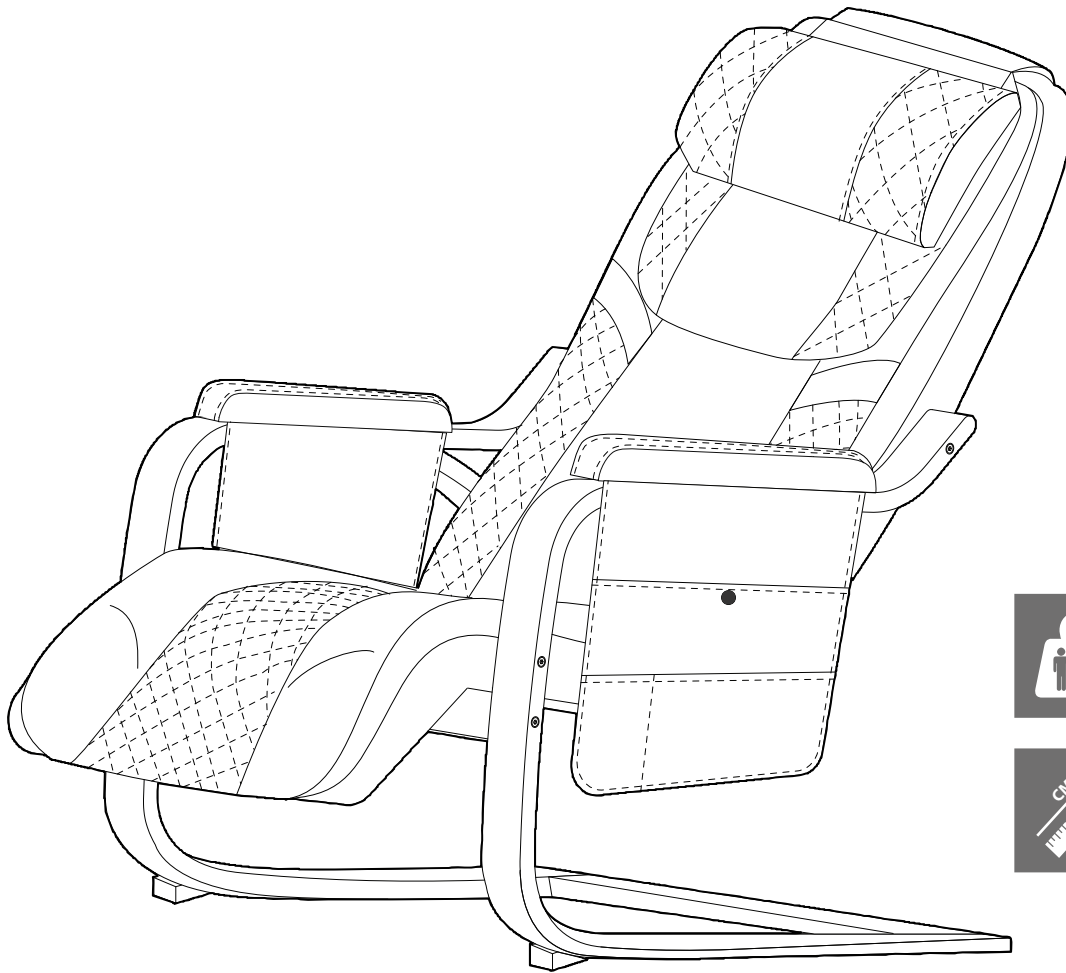

# TAURUS WELLNESS

## Assembly and Operating Instructions



max. 120 kg



22 kg

L 120 | W 67 | H 99

FSTWWMCG.01.04  
FSTWWMCB.01.04

Art. No. TW-WMC-G/B



# Content

<b>1</b>	<b>GENERAL INFORMATION</b>	<b>8</b>
1.1	Technical Data	8
1.2	Personal Safety	9
1.3	Electrical Safety	10
1.4	Set-Up Place	10
<b>2</b>	<b>ASSEMBLY</b>	<b>11</b>
2.1	General Instructions	11
2.2	Overview	12
2.3	Scope of Delivery	13
2.4	Assembly	15
<b>3</b>	<b>OPERATING INSTRUCTIONS</b>	<b>17</b>
3.1	Display	17
<b>4</b>	<b>STORAGE AND TRANSPORT</b>	<b>20</b>
4.1	General Instructions	20
<b>5</b>	<b>TROUBLESHOOTING, CARE AND MAINTENANCE</b>	<b>20</b>
5.1	General Instructions	20
5.2	Faults and Fault Diagnosis	21
5.3	Error Codes and Troubleshooting	21
5.4	Maintenance and Inspection Calendar	22
<b>6</b>	<b>DISPOSAL</b>	<b>22</b>
<b>7</b>	<b>ORDERING SPARE PARTS</b>	<b>23</b>
7.1	Serial Number and Model Name	23
7.2	Parts List	24
7.3	Exploded Drawing	25
<b>8</b>	<b>WARRANTY</b>	<b>26</b>
<b>9</b>	<b>CONTACT</b>	<b>28</b>





**Dear customer,**

Thank you for choosing a wellness device of the brand Taurus Wellness®. With the Taurus Wellness line, we offer you relaxation, regeneration and massage for your home. In this way, the Taurus Wellness line can contribute to greater health and well-being. We wish you a relaxing time. If you have any questions about these or other devices of the Taurus Wellness brand, please feel free to contact us.

Your team from Taurus Wellness and the Fitshop Group.

**Intended Use**

The equipment may only be used for its intended purpose.

The equipment is only suitable for home use. The equipment is not suitable for semi-professional (e.g. hospitals, associations, hotels, schools, etc.) and commercial or professional use (e.g. fitness studios).

**Legal Notice**

Fitshop GmbH  
Europe's No. 1 for home fitness

International Headquarters  
Flensburger Straße 55  
24837 Schleswig  
Germany

Management:  
Christian Grau  
Sebastian Campmann  
Dr. Bernhard Schenkel  
No. HRB 1000 SL  
Local Court Flensburg  
European VAT Number: DE813211547

**Disclaimer**

© Taurus Wellness is a registered brand of the company Fitshop GmbH. All rights reserved. Any use of this trademark without the explicit written permission of Fitshop is prohibited.

Product and manual are subject to change. Technical data can be changed without advance notice.

**FITSHOP**

Europe's No.1 for Home Fitness



## ABOUT THIS MANUAL

Please carefully read the entire manual before installation and first use. The manual will help you to quickly set up the system and explains how to safely use it. Make sure that all persons exercising with the equipment (especially children and persons with physical, sensory, mental or motor disabilities) are informed about this manual and its contents in advance. In case of doubt, responsible persons must supervise the use of the equipment.

Due to ongoing changes and software optimisations, the manual may have to be updated. If you notice any discrepancies during assembly or use, please refer to the manual uploaded to the webshop. The latest manual is always available there.



This equipment has been manufactured according to the latest safety knowledge. As far as possible, potential safety hazards which could cause injury have been eliminated. Make sure to carefully follow the instructions and that all parts are securely in place. If required, read through the instructions again to correct any mistakes.

Training devices must be classified according to accuracy and use. Accuracy classes are only applicable to devices that display training data.

### Accuracy classes

Class A: high accuracy.

Class B: medium accuracy.

Class C: low accuracy.

The use classes explain the intended use of the training device.

### Use classes

**Class S** (studio): professional and/or commercial use.

These training devices are intended for the use in training rooms of facilities such as sports clubs, school facilities, hotels, clubs and studios whose access and supervision is specifically regulated by the owner (person with legal responsibility).

**Class H** (home use): use at home.

These stationary training devices are intended for the use in private homes where access to the training device is regulated by the owner (person with legal responsibility).



Please pay close attention to the safety and maintenance instructions given here. The contract partner cannot be held liable for damage to health, accidents or damage to the equipment when it is not used in accordance with these instructions.

The following safety instructions may appear in this manual:



**ATTENTION**

This notice indicates potentially hazardous situations which, if not avoided, may result in property damage.



**CAUTION**

This notice indicates potentially hazardous situations which, if not avoided, may result in slight or minor injuries!



**WARNING**

This notice indicates potentially hazardous situations which, if not avoided, may result in death or serious injuries!



**DANGER**

This notice indicates potentially hazardous situations which, if not avoided, will result in death or serious injuries!



**NOTICE**

This notice indicates further useful information.

Retain these instructions in a safe place for future reference, maintenance or when ordering replacement parts.



## 1.1 Technical Data

### Weight and dimensions

Package dimensions (L x W x H) approx.:	90 cm x 43.5 cm x 62.5 cm
Set-up dimension (L x W x H) approx.:	120 cm x 67 cm x 99 cm
Article weight (gross, incl. packaging) approx.:	25 kg
Article weight (net, excl. packaging) approx.:	22 kg
Maximum user weight:	120 kg
Use class:	H



## 1.2 Personal Safety

### **WARNING**

- + Before you start using the equipment, you should consult your physician that this type of exercise is suitable for you from a health perspective. This applies in particular to:
  - + People with pacemakers or other medical devices that can cause electromagnetic interference.
  - + People with cardiovascular diseases.
  - + Pregnant women, sick persons or persons in poor physical condition.
- + Children should not be allowed unsupervised access to the equipment.
- + Persons with disabilities must have a medical license and must be under strict observation when using the equipment.
- + The equipment is strictly for use by one person at a time.
- + The owner must communicate all warnings and instructions to the user.
- + Do not use the device in rooms where aerosol sprays or oxygen are administered.
- + Keep your hands, feet and other body parts, hair, clothing, jewellery and other objects well clear of moving parts.
- + Do not use the device on swollen and/or inflamed parts of the body or on irritated skin regions.
- + Should you experience unusual discomfort during the use, switch the device off and do not use it any further. Get in contact with a doctor.
- + If the device or power cable happens to be damaged, refrain from using the device.
- + The appliance must not come into contact with water/liquids.
- + Do not drop any objects on the appliance.
- + Do not attempt to dismantle the appliance yourself.

### **ATTENTION**

- + Do not insert any objects of any kind into the openings of the device.



## 1.3 Electrical Safety

### **DANGER**

- + In order to reduce the risk of an electric shock, always unplug the equipment from the mains socket immediately after your workout, before assembly or dismantling, and before maintenance or cleaning. Do not pull on the cable.

### **WARNING**

- + Do not leave the equipment unattended while the mains cable is plugged into the mains socket. During your absence, the mains cable must be removed from the mains socket to prevent improper use by third parties or children.
- + If the mains cable or plug is damaged or defective, contact your contract partner. Until repair, the equipment must not be used.

### **ATTENTION**

- + The equipment requires a mains connection of 220-230 V with 50 Hz mains voltage.
- + The equipment may only be connected directly to an earthed socket using the supplied mains cable. Extension cables must conform to VDE guidelines. Always completely unwind the mains cable.
- + The socket must be protected by a fuse with a minimum fuse rating of "16 A, slow blow".
- + Do not make any changes to the mains cable or the mains plug.
- + Keep the mains cable away from water, heat, oil and sharp edges. Do not route the mains cable underneath the equipment or under a carpet or rug, and do not place any objects on top of it.

## 1.4 Set-Up Place

### **WARNING**

- + Do not place the equipment in main corridors or escape routes.
- + To avoid fires, do not place the appliance near or in rooms with high heat (e.g. near a heater).

### **CAUTION**

- + Choose the place in which to set up the equipment such that there is enough free space/clearance to the front, the rear and to the sides of the equipment.
- + The set-up and mounting surface of the equipment should be flat, loadable and solid.

### **ATTENTION**

- + The device may only be used in one building, in sufficiently tempered and dry rooms (ambient temperatures between 10°C and 35°C). The equipment should not be used outdoors or in rooms with high humidity (over 70%) like swimming pools.
- + A floor protective mat/equipment underlay can help to protect high-quality floor coverings (parquet, laminate, cork, carpets) from dents and sweat and can help to level out slight unevenness.
- + To prevent the cover from fading or wearing out more quickly, do not place the unit in locations exposed to direct sunlight and/or high heat.



## 2.1 General Instructions



### DANGER

- + Do not leave any tools, packaging materials such as foils or small parts lying around, as otherwise there is a danger of suffocation for children. Keep children away from the equipment during assembly.



### WARNING

- + Pay attention to the instructions attached to the equipment in order to reduce the risk of injuries.



### CAUTION

- + Ensure to have sufficient room for movement in each direction during assembly.
- + The assembly of the equipment must be carried out by at least two adults. If in doubt, seek the help of a third technically skilled person.



### ATTENTION

- + To prevent damage to the equipment and the floor, assemble the equipment on a mat or packaging board.



### NOTICE

- + Ideally, assemble the equipment at its later set-up place.



## 2.2 Overview

### ① NOTICE

If you have difficulty recognising the graphics, we recommend that you open and/or download the PDF instructions stored in the webshop on your end device (e.g. smartphone, tablet or PC). There you have the option of zooming in closer. Please note that the Adobe Acrobat Reader programme must be installed on your end device in order to open the file.

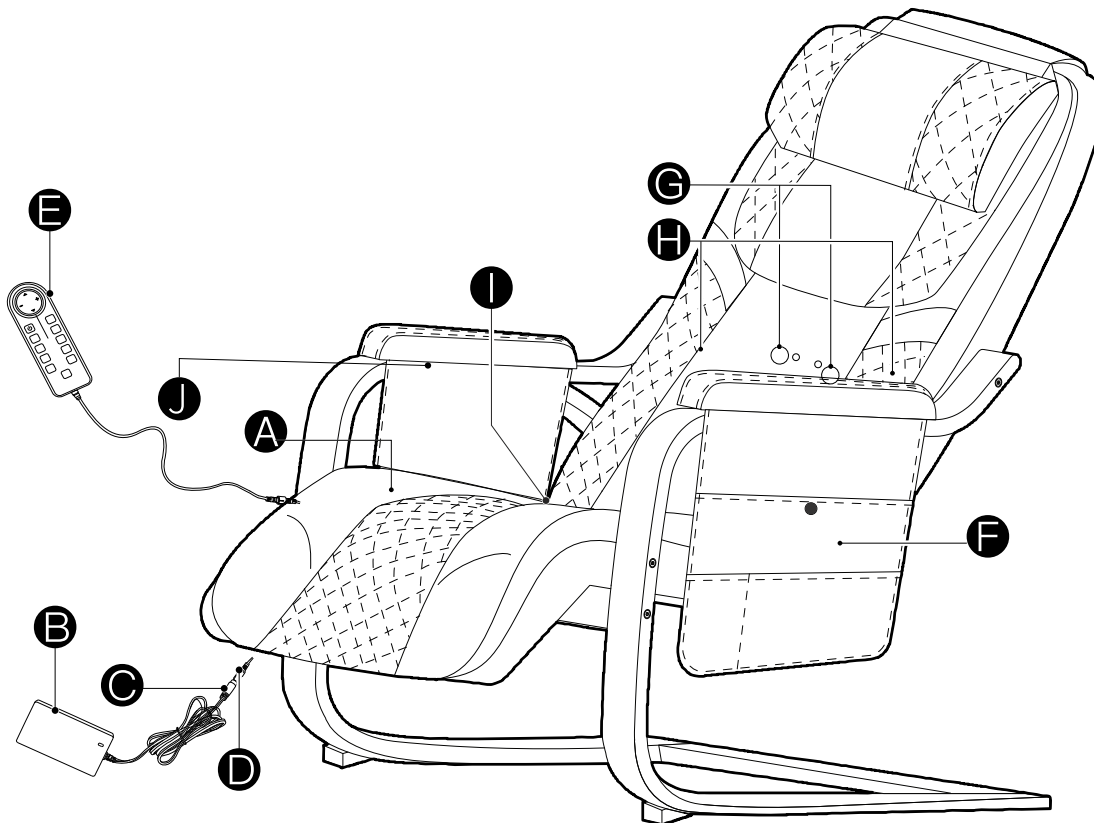

Ⓐ Hand Controller Pocket

Ⓑ Adaptor

Ⓒ Adaptor Output Line Head

Ⓓ DC Input Line Head

Ⓔ Hand Controller

Ⓕ Left Armrest Pouch

Ⓖ Back Massage Head

Ⓗ Heater

Ⓘ High Frequency Vibration Motor

Ⓙ Right Armrest Pouch

## 2.3 Scope of Delivery



The scope of delivery consist of the following parts. At the beginning, check whether all parts and tools belonging to the device are included in the scope of delivery and whether damage has occurred. In the event of complaints, the contractual partner must be contacted directly.

**⚠ CAUTION**

If parts of the scope of delivery are missing or damaged, the assembly must not be carried out.

**📄 NOTICE**

Required Tools: Allen Key (Included in the delivery)

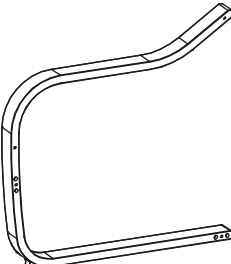
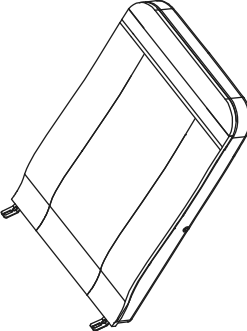
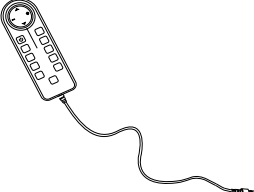
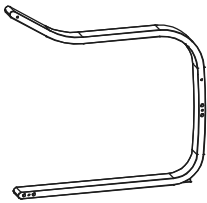
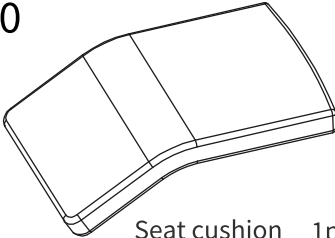
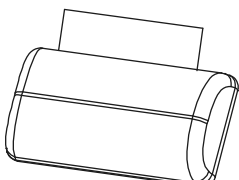
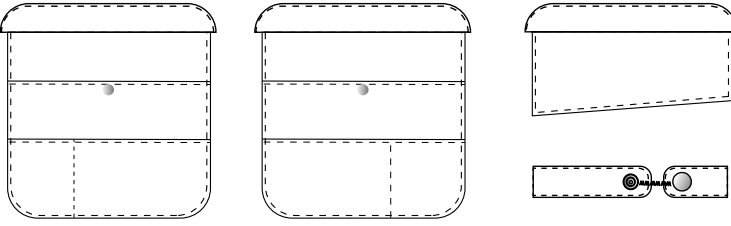
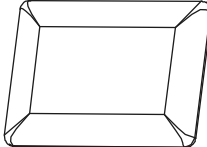
<p>5</p>  <p>Allen Key 1pc</p>	<p>8</p>  <p>Beam 2pcs</p>	<p>11</p>  <p>Adaptor 1pc</p>
<p>6</p>  <p>Wooden frame-right 1pc</p>	<p>9</p>  <p>Backrest 1pc</p>	<p>12</p>  <p>Hand Controller 1pc</p>
<p>7</p>  <p>Wooden frame-left 1pc</p>	<p>10</p>  <p>Seat cushion 1pc</p>	<p>13</p>  <p>Neck pillow 1pc</p>
<p>15</p>  <p>Left Right Armrest Pouch 1SET</p>		<p>14</p>  <p>Cushion 1pc</p>

1



Screw M6x90 4x

2

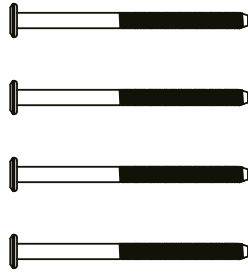

Screw M6x110 4x

3

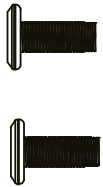

Screw M6x30 2x

4

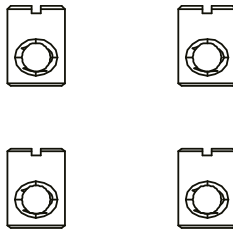

Offset nuts M6 4PCS

## 2.4 Assembly

Before assembly, take a close look at the individual assembly steps shown and carry out the assembly in the order given.

### NOTICE

- + First loosely screw all parts together and check that they fit properly. Tighten the screws using the tool only when you are instructed to do so.

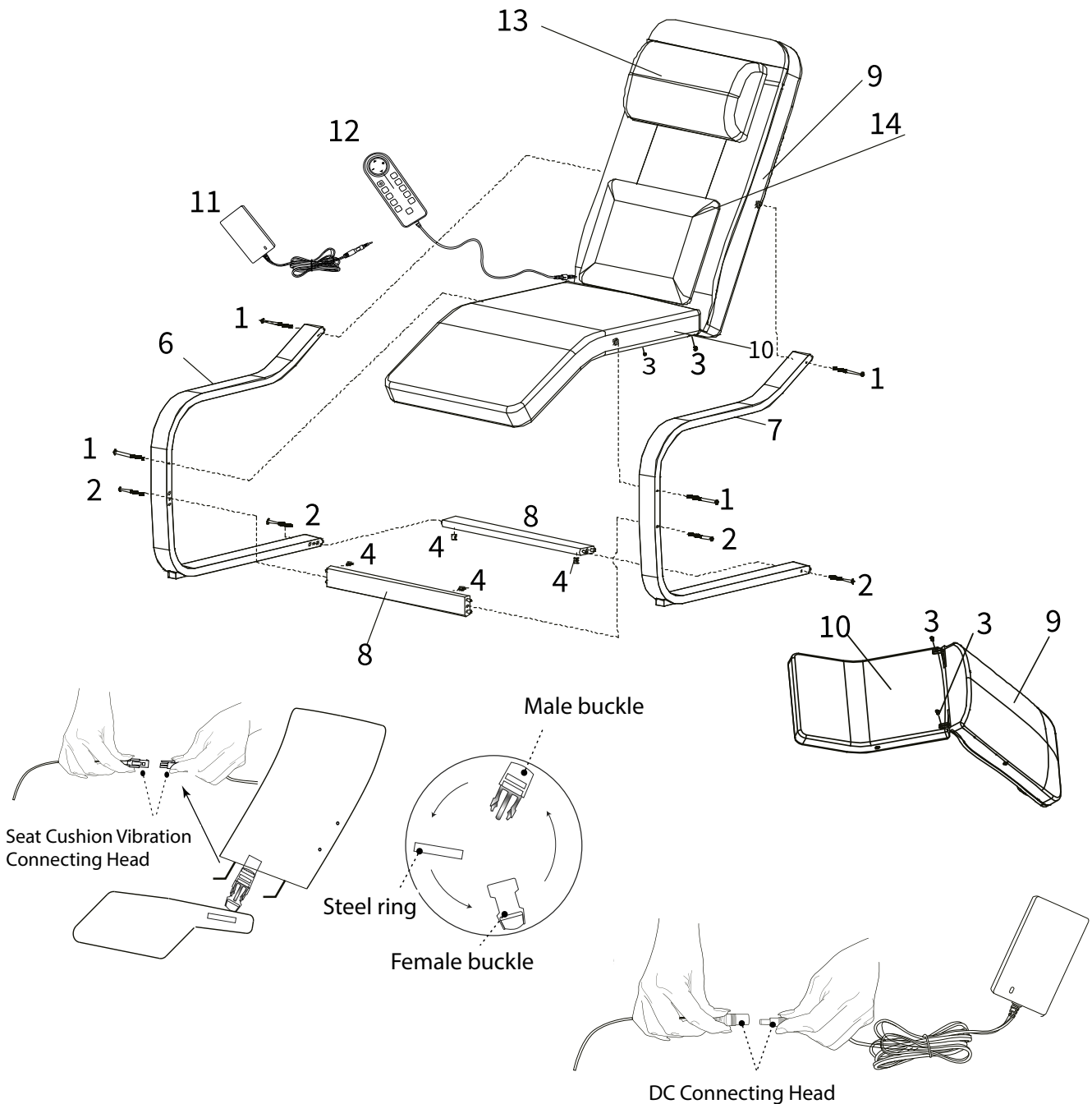

### **Step 1: Assembling the armchair**

1. Connect the right-hand frame (6) to the seat cushion (10) with two screws (1) and two screws (2).

*Use the Allen key for this.*

2. Fit the two cross struts (8) to the right-hand frame (6).
3. Place a total of four clamping wedges (4) in the cross struts (8).
4. Attach the seat cushion (10) to the backrest cushion (9) using the screw holes provided.
5. Secure the seat cushion (10) to the backrest cushion (9) using the buckle fastener.
6. Repeat steps 1 and 2 for the left frame (7).
7. Fasten the screws (2) to the cross struts (8).
8. Attach the seat cushion (10) to the back cushion (9) on the hooks using the screws (3).

*Use the Allen key for this.*

### **Step 2: Connect the cables**

1. Connect the cables of the seat cushion (10) and the backrest cushion (9).
2. Connect the remote control (12).
3. Connect the adapter (11).

### **Step 3: Fitting the upholstery**

1. Secure the left and right upholstery (15) to the armrests.
2. Place the neck cushion (13) over the back cushion (9).
3. Place the cushion (14) on the backrest cushion (9).



## 3 OPERATING INSTRUCTIONS





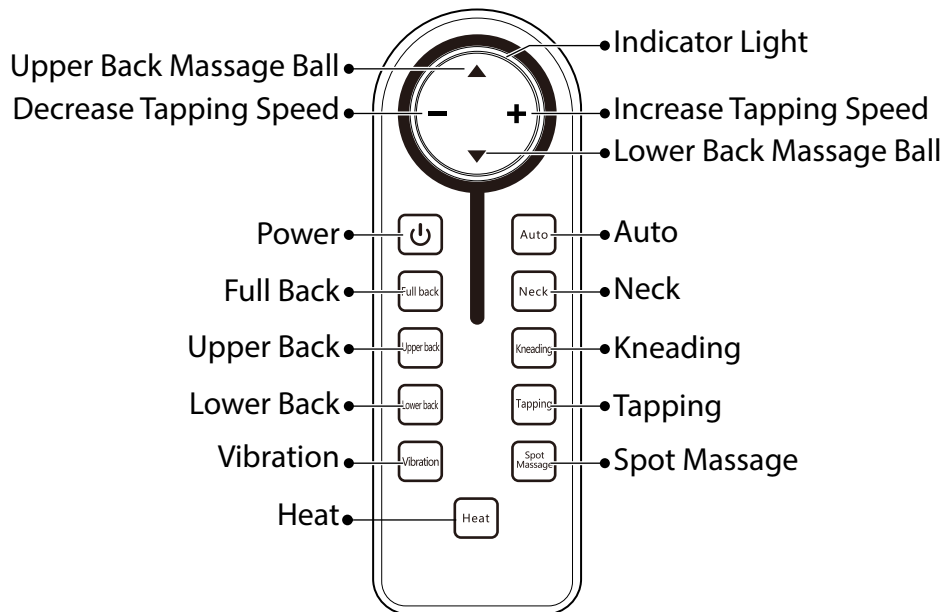





### NOTICE



Familiarise yourself with all the functions and setting options of the device before starting training. Have the proper use of this product explained to you by a specialist.

### 3.1 Display



Display	Function
	<p><b>Power On/Off:</b></p> <ul style="list-style-type: none"> <li>+ Press this button to turn on the massage chair.</li> <li>+ Press the button again to turn off the massage chair.</li> </ul>
	<p><b>Auto Mode 1 and 2:</b> Press this button to start Auto Mode 1.</p> <p><b>NOTICE</b> In Auto Mode 1, you can adjust the shoulder position. If no input is made within 8 seconds after starting Auto Mode 1, Auto Mode 2 will start automatically. This is a fully automatic massage.</p> <p><b>NOTICE</b> No adjustments can be made in Auto Mode 2.</p>

 	<p><b>Shoulder Position:</b> Press these buttons to adjust the shoulder position.</p> <p><b>NOTICE</b> Manual adjustment of the shoulder position does not work in Auto Mode 2.</p>
	<p><b>Neck Massage:</b></p> <ul style="list-style-type: none"> <li>+ Press this button to activate the neck massage.</li> <li>+ Press the button again to change the direction of the massage movement.</li> </ul>
	<p><b>Heating Function:</b></p> <ul style="list-style-type: none"> <li>+ Press this button to turn on the heating function.</li> <li>+ Press the button again to turn off the heating function.</li> </ul>
	<p><b>Vibration:</b></p> <ul style="list-style-type: none"> <li>+ Press this button to activate the vibration function.</li> <li>+ Press again to increase the intensity.</li> </ul> <p><b>NOTICE</b> There are three intensity levels.</p> <ul style="list-style-type: none"> <li>+ To turn off the function, press the button again when the highest intensity is selected.</li> </ul>
	<p><b>Spot Massage Function:</b></p> <ul style="list-style-type: none"> <li>+ Start a massage mode. (This does not work in Auto Mode.)</li> <li>+ To select the starting point, press "Spot Massage".</li> <li>+ To select the end point, press "Spot Massage" again.</li> </ul> <p><b>NOTICE</b> If a massage cycle occurs (the rollers move from the downward to the upward motion or vice versa) after selecting the starting point, the function will be canceled.</p>
	<p><b>Back Massage:</b> Press this button to activate the back massage.</p>
	<p><b>Neck Massage:</b> Press this button to activate the neck massage.</p>
	<p><b>Lower Back Massage:</b> Press this button to start the lower back massage.</p>
	<p><b>Kneading Massage:</b></p> <ul style="list-style-type: none"> <li>+ Press this button to select the kneading massage.</li> <li>+ To target specific massage areas, press "Lower back", "Upper back", or "Full back".</li> </ul>

	<p><b>Tapping Massage:</b></p> <ul style="list-style-type: none"><li>+ Press this button to select the tapping massage.</li><li>+ To target specific massage areas, press “Lower back”, “Upper back”, or “Full back”.</li></ul> <p><b>NOTICE</b></p> <ul style="list-style-type: none"><li>+ There are two tapping massage variations.</li><li>+ To switch between the variations, press “Tapping” again.</li></ul>
 	<p><b>Tapping Massage:</b></p> <ul style="list-style-type: none"><li>+ Press this button to adjust the tapping speed.</li><li>+ There are three speed levels.</li></ul>

## 4.1 General Instructions

### **WARNING**

- + The storage location should be chosen so that improper use by third parties or children can be prevented.
- + If your equipment does not have transportation wheels, the equipment must be disassembled before transportation.

### **ATTENTION**

- + Make sure that the equipment is protected from moisture, dust and dirt in the selected storage location. The storage location should be dry and well ventilated and have a constant ambient temperature between 10°C and 35°C.

## 5.1 General Instructions

### **WARNING**

- + Do not make any improper changes to the equipment.

### **CAUTION**

- + Damaged or worn components may affect your safety and the life of the equipment. Therefore, immediately replace damaged or worn components. In such a case, contact the contract partner. The equipment must not be used until it has been repaired. If necessary, use only original spare parts.

### **ATTENTION**

- + In addition to the instructions and recommendations for maintenance and care given here, additional service and/or repair work may be necessary; this must only be carried out by authorised service technicians.

## 5.2 Faults and Fault Diagnosis

The equipment undergoes regular quality controls during production. Nevertheless, faults or malfunctions may occur. Frequently, individual parts are responsible for these disturbances, an exchange is usually sufficient. Please refer to the following overview for the most common errors and how to correct them. If the equipment still does not function properly, contact your contract partner.

Fault	Cause	Solution
The device does not work	Interrupted power connection	+ Check cable connection + Power switch to on
	Excessive use of the device	Disconnect the device from the mains socket and allow the device to cool down for at least 60 minutes before using it again.
	Heavy load on the device	Reduce the load on the device
The device is unusually warm	Excessive use of the device	Disconnect the device from the mains socket and allow the device to cool down for at least 60 minutes before using it again.
The device makes noise	Noise caused by the mechanical parts of the device	Noise during use of the device is normal. If the noises sound unusual (crackling, squeaking etc.), contact your contract partner.

## 5.3 Error Codes and Troubleshooting

The electronics of the equipment continuously carries out tests. In case of deviations, an error code appears on the display and normal operation is stopped for your safety.

**Please contact the contract partner for technical support.**



## 5.4 Maintenance and Inspection Calendar

To avoid damage from body sweat, the equipment must be cleaned with a damp towel (no solvents!) after each training session.

The following routine tasks must be performed at the specified intervals:

Part	Weekly	Monthly	Quarterly	Half-yearly	Yearly
Plastic covers	C	I			
Screws and cable connections		I			
Legend: C = clean; I = inspect					

## 6 DISPOSAL

At the end of its operational life, this equipment cannot be disposed of in normal household waste. Instead, it must be disposed of via an electricals recycling centre. Further information can be obtained from your local authority's recycling service.



The materials can be recycled as per their symbols. Through the reuse, recycling of materials or other forms of recovery of old equipment, you make an important contribution to the protection of the environment.

## 7.1 Serial Number and Model Name

In order to provide you with the best possible service, please have the model name, article number, serial number, exploded drawing and parts list ready. The corresponding contact options can be found in chapter 9 of this operating manual.

**NOTICE**

The serial number of your equipment is unique. It's located on a white sticker.

Enter the serial number in the appropriate field.

**Serial number:**

**Brand / Category:**

**Model Name:**

**Article Number:**



## 7.2 Parts List

No.	Name	Specification	Qty.
17	3.1.10203045365	PCB	pc
16	3.3.12213034396	Vibration Motor	pc
12	2.1.10203045348	Hand Controller	set
11	3.2.11203047579	Adaptor	pc
1-5	3.2.10203061535	Tool set	set
7	2.2.11203047555-1	TW-WMC-B-Wooden Frames-Left	set
6	2.2.11203047555-2	TW-WMC-B-Wooden Frames-Right	set
7	2.2.11203047555-3	TW-WMC-G-Wooden Frames-Left	set
6	2.2.11203047555-4	TW-WMC-G-Wooden Frames-Right	set
8	3.2.11203047897-1	TW-WMC-B-Wooden Frames-Crossrail	pc
8	3.2.11203047897-2	TW-WMC-G-Wooden Frames-Crossrail	pc
10	2.2.11203047560-1	TW-WMC-B-Cushion cloth cover	set
10	2.2.11203047560-2	TW-WMC-G-Cushion cloth cover	set
9	2.2.11203047568-1	TW-WMC-B-Cloth cover for backrest	set
9	2.2.11203047568-2	TW-WMC-G-Cloth cover for backrest	set
9	2.2.11203047561-1	TW-WMC-B-Kneading Fabric	set
9	2.2.11203047561-2	TW-WMC-G-Kneading Fabric	set
13	2.2.11203047562-1	TW-WMC-B-Neck Pillow	set
13	2.2.11203047562-2	TW-WMC-G-Neck Pillow	set
13	2.2.11203047563-3	TW-WMC-B-Neck Pillow	set
13	2.2.11203047563-4	TW-WMC-G-Neck Pillow	set
14	2.1.10203047016-1	TW-WMC-B-Armrest Pouches-Left	set
14	2.1.10203047016-2	TW-WMC-B-Armrest Pouches-Right	set
14	2.1.10203047016-3	TW-WMC-G-Armrest Pouches-Left	set
14	2.1.10203047016-4	TW-WMC-G-Armrest Pouches-Right	set
15	2.1.10203047014-1	TW-WMC-B-Cushion	set
15	2.1.10203047014-2	TW-WMC-G-Cushion	set
18	2.1.17220045736	Back Mechanism	set
19	3.1.10203045364	Mechanism Wire	set

## 7.3 Exploded Drawing

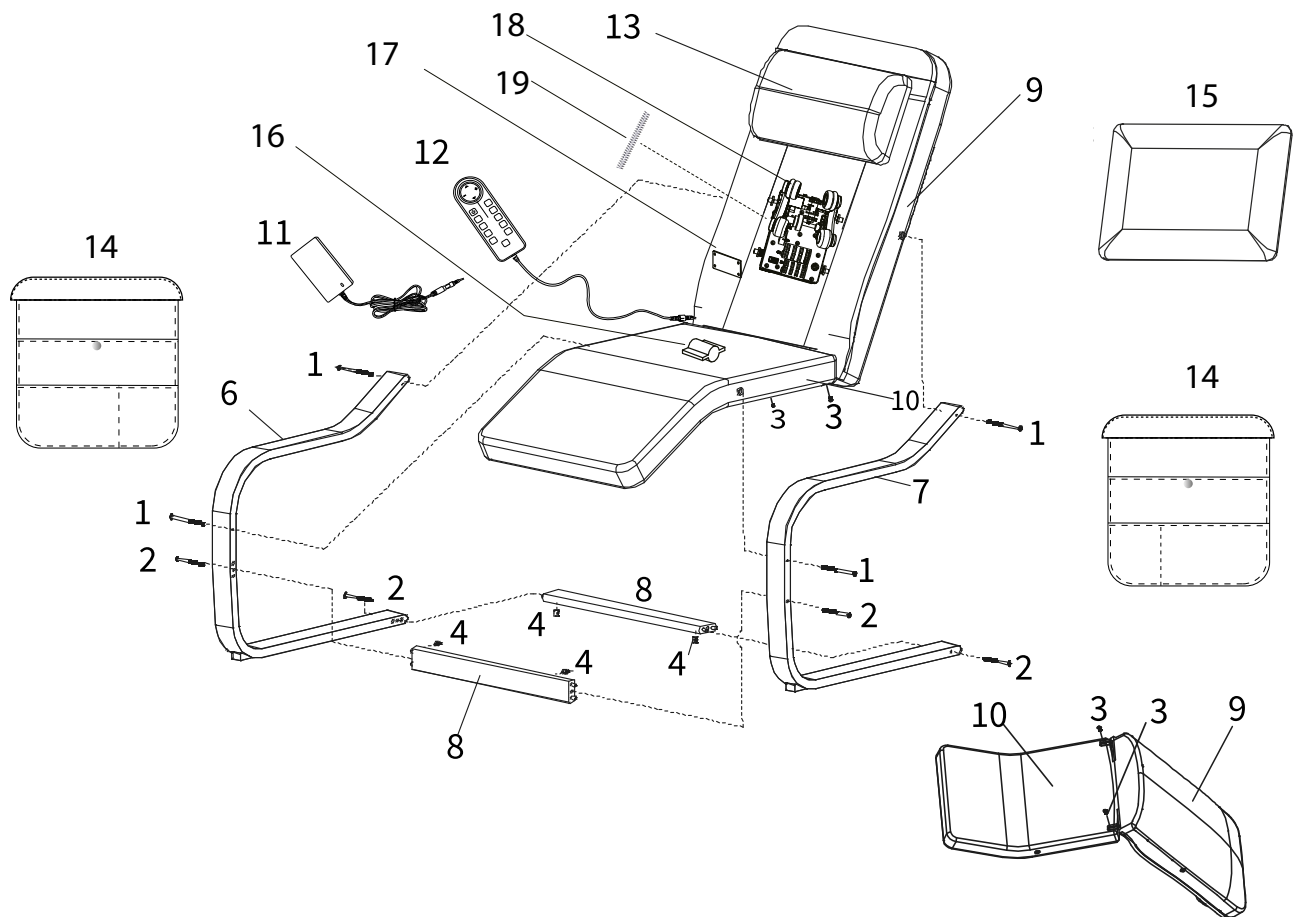

Products from Taurus Wellness® are subject to strict quality control. However, if a fitness equipment purchased from us does not work perfectly, we take it very seriously and ask you to contact our customer service as indicated. We are happy to help you by phone via our service hotline.

### **Error Descriptions**

Your fitness equipment is developed for long-term, high-quality training. However, should a problem arise, please first read the operating instructions. For further assistance, please contact your contract partner or call our service hotline. To ensure your problem is solved as quickly as possible, please describe the defect as exactly as possible.

In addition to the statutory warranty, we provide a warranty for every fitness equipment purchased from us according to the following provisions.

**Your statutory rights are not affected.**

### **Warrantee**

The warrantee is the first/original buyer and/or any person who received a newly purchased product as a gift from the original buyer.

### **Warranty period**

The warranty periods, shown on our web shop, begin on delivery of the fitness equipment. The respective warranty periods for your equipment can be found on its product website.

### **Repair Costs**

According to our choice, there will either be a repair, a replacement of individual damaged parts or a complete replacement. Spare parts, that have to be mounted while assembling the equipment, have to be replaced by the warrantee personally and are not a part of repair. After the expiration of the warranty period, the responsibility for parts costs, repair costs, installation costs and delivery costs lies with the warranty holder.

### **The terms of use are defined as follows:**

- + Home use: solely for private use in private households up to 3 hours per day
- + Semi-professional use: up to 6 hours per day (e. g. rehabilitation centres, hotels, clubs, company gyms)
- + Professional use: more than 6 hours per day (e. g. commercial gyms)

### **Warranty Service**

Within the warranty period, equipment which develops faults as a result of material or manufacturing defects, will be repaired or replaced at our discretion. Ownership of equipment or parts of equipment which have been replaced is transferred to us. The warranty period is not extended nor does a new warranty period begin following repair or replacement under the warranty.



## Warranty Conditions

For the warranty to be valid, the following steps must be taken:

Please contact our customer service by email or phone. If the product under warranty has to be sent in for repair, the seller bears costs. After expiry of the warranty, the buyer bears the costs of transport and insurance. If the fault is covered by our warranty, you will receive a new or repaired equipment in return.

### Warranty claims are invalid in case of damage resulting from:

- + misuse or improper handling
- + environmental influences (moisture, heat, electrical surge, dust, etc.)
- + failure to follow the current safety measures for the equipment
- + failure to follow the operating instructions
- + use of force (e. g. hitting, kicking, falling)
- + interventions which were not carried out by one of our authorized service centres
- + unauthorised repair attempts

### Proof of Purchase and Serial Number

Please make sure that you are able to provide the appropriate receipt when claiming on your warranty. So that we can clearly identify the model of your equipment, and for the purposes of our quality control, you will need to give the serial number of your equipment, when contacting the service team. Where possible please have your serial number and your customer number ready when you call our service hotline. It will help us to deal with your request swiftly.

If you cannot find the serial number on your fitness equipment, our service team is at your disposal to offer further information.

### Service outside of the Warranty Period

We are also happy to issue an individual cost estimate if there is a problem with your fitness equipment after the warranty has expired, or in cases which do not fall under the terms of the warranty, e. g. normal wear and tear. Please contact our customer service team to find a quick and cost-effective solution to your problem. In such a case you will be responsible for the delivery costs.

### Communication

Many problems can be solved just by speaking to us as your specialist supplier. We know how important it is to you as a user of the fitness equipment to have problems solved quickly and simply, so you can enjoy working out with minimal interruption. For that reason, we also want to resolve your queries quickly and in a straightforward manner. Thus, please always keep your customer number and the serial number of the faulty equipment handy.



DE	DK	UK
<p><b>TECHNIK</b></p> <p>☎ +49 4621 4210-900            📠 +49 4621 4210-698            ✉ technik@fitshop.de            🕒 Öffnungszeiten entnehmen Sie unserer Homepage.</p> <p><b>SERVICE</b></p> <p>☎ 0800 20 20277 (kostenlos)            ☎ 04621 4210 - 0            ✉ info@fitshop.de            🕒 Öffnungszeiten entnehmen Sie unserer Homepage:  <a href="https://stg.fit/statita">https://stg.fit/statita</a></p>	<p><b>TEKNIK OG SERVICE</b></p> <p>☎ 80 90 16 50            +49 4621 4210-945            ✉ info@fitshop.dk            🕒 Åbningstider kan findes på hjemmesiden:  <a href="https://stg.fit/statit7">https://stg.fit/statit7</a></p>	<p><b>CUSTOMER SUPPORT</b></p> <p>☎ 00800 2020 2772            +494621 4210 944            ✉ info@fitshop.co.uk            🕒 You can find the opening hours on our homepage:  <a href="https://stg.fit/statitc">https://stg.fit/statitc</a></p>
	FR	BE
	<p><b>TECHNIQUE &amp; SERVICE</b></p> <p>☎ +33 (0) 189 530984            +49 4621 42 10 933            ✉ info@fitshop.fr            🕒 Vous trouverez les heures d'ouverture sur notre site Internet:  <a href="https://stg.fit/statit4">https://stg.fit/statit4</a></p>	<p><b>TECHNIQUE &amp; SERVICE</b></p> <p>☎ 02 732 46 77            +49 4621 4210 933            ✉ info@fitshop.be            🕒 Vous trouverez les heures d'ouverture sur notre site Internet:  <a href="https://stg.fit/statit8">https://stg.fit/statit8</a></p>
ES	NL	INT
<p><b>TECNOLOGÍA Y SERVICIOS</b></p> <p>☎ 911 238 029            ✉ info@fitshop.es            🕒 Consulta nuestro horario de apertura en la página web:  <a href="https://stg.fit/statit5">https://stg.fit/statit5</a></p>	<p><b>TECHNISCHE DIENST &amp; SERVICE</b></p> <p>☎ +31 172 619961            ✉ service@fitshop.nl            🕒 De openingstijden vindt u op onze homepage:  <a href="https://stg.fit/statit3">https://stg.fit/statit3</a></p>	<p><b>TECHNICAL SUPPORT &amp; SERVICE</b></p> <p>☎ +49 4621 4210-944            ✉ service-int@fitshop.de            🕒 You can find the opening hours on our homepage:  <a href="https://stg.fit/statita">https://stg.fit/statita</a></p>
PL	AT	CH
<p><b>DZIAŁ TECHNICZNY I SERWIS</b></p> <p>☎ 22 307 43 21            +49 4621 42 10-948            ✉ info@fitshop.pl            🕒 Godziny otwarcia można znaleźć na stronie głównej:  <a href="https://stg.fit/statit6">https://stg.fit/statit6</a></p>	<p><b>TECHNIK &amp; SERVICE</b></p> <p>☎ 0800 20 20277 (Freecall)            +49 4621 42 10-0            ✉ info@fitshop.at            🕒 Öffnungszeiten entnehmen Sie unserer Homepage:  <a href="https://stg.fit/statitb">https://stg.fit/statitb</a></p>	<p><b>TECHNIK &amp; SERVICE</b></p> <p>☎ 0800 202 027            +49 4621 42 10-0            ✉ info@fitshop.ch            🕒 Öffnungszeiten entnehmen Sie unserer Homepage:  <a href="https://stg.fit/statit9">https://stg.fit/statit9</a></p>

Please find a detailed overview including address and opening hours for all stores of the Fitshop Group in Germany and abroad on the following website:

[www.fitshop.com/en/stores](http://www.fitshop.com/en/stores)



# WE LIVE FITNESS

## WEBSHOP AND SOCIAL MEDIA

Fitshop is Europe's largest specialist store for home fitness equipment with currently over 65 stores and one of the world's most renowned online mail order companies for fitness equipment. Private customers order via the 25 web shops in the respective national language or have their desired equipment assembled on site. In addition, the company supplies fitness studios, hotels, sports clubs, companies and physio practices with professional equipment for endurance and strength training.

Fitshop offers a wide range of fitness equipment from renowned manufacturers, high-quality in-house developments and comprehensive services, such as a build-up service and sports scientific advice before and after the purchase. The company employs numerous sports scientists, fitness trainers and competitive athletes.

Visit us also on our social media platforms or our blog!

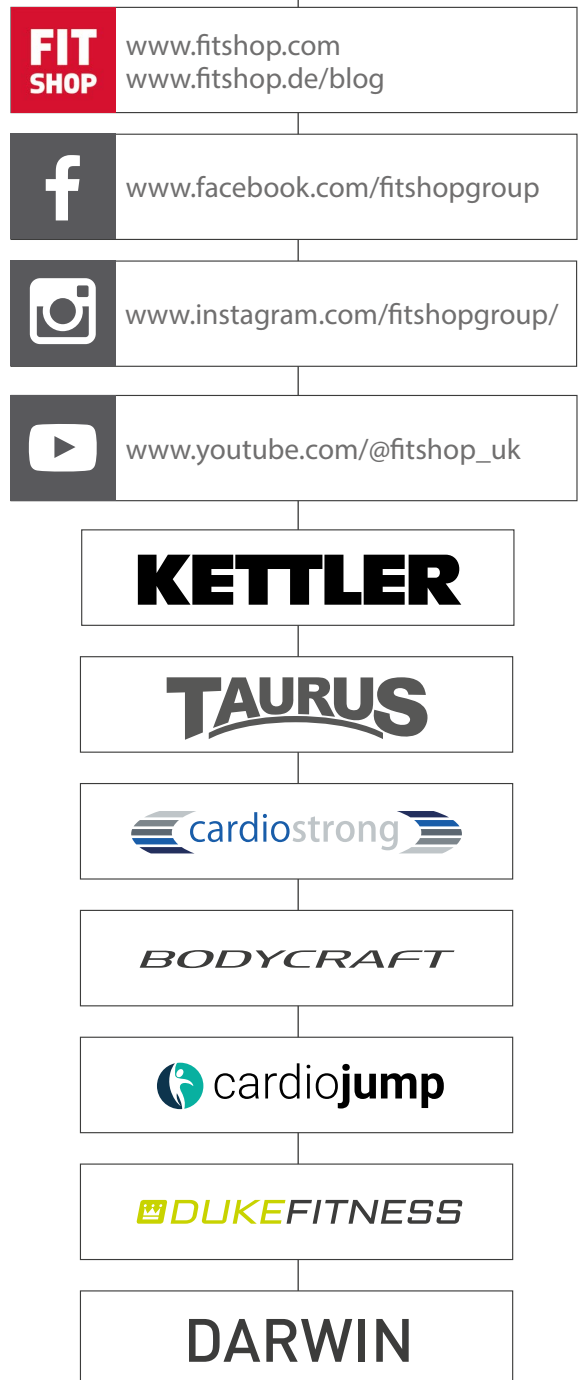

Notes





