

PLEASE READ INSTRUCTIONS FULLY BEFORE STARTING ASSEMBLY

COMPONENTS

Main Parts

- A Mono Rail Assembly (with seat)
- B Tank Assembly
- C Sub Rails × 2
- D Footboard

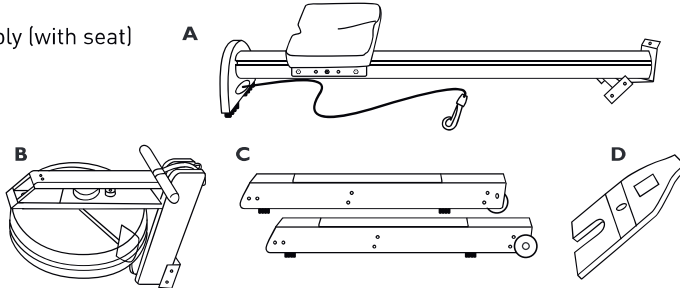

Other Parts

- E JCB 23mm (WRB-B700) × 8
- F JCN (WRP-B711) × 8
- G Handle Rest (WRP-P430) × 2
- H Handle Rest Bolt (WRP-P455) × 2
- I Clamp Bar Bolt (WRP-P1140) × 1
- J Rail Sub Bracket Bolt (WRP-S201) × 1
- K Back of Footboard Bolt (WRP-B720) × 4*
- L Rail Sub Bracket (WRP-R1500) × 1
- M 5mm Allen Key (WRP-B740) × 1
- N Heel Rests (WRP-P1700) × 2
- O Syphon Pump (WRP-B405) × 1
- P Purification Tablets (WRP-B960)

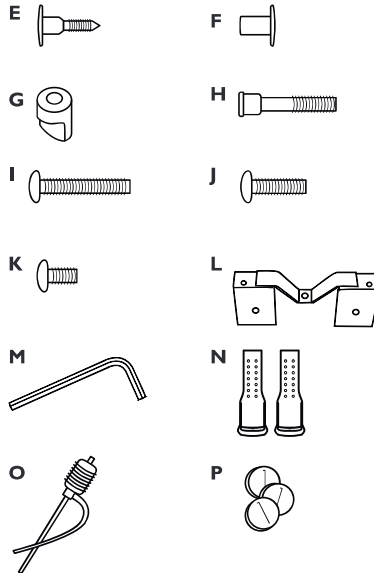

*K Bolts are located on the back of footboard [see step 3]

STEP 1

Lay the sub rails on the floor with ends parallel. Dolly wheels on the outside.

Attach the end of the mono rail to the angled ends of the sub rails with the Allen key (M) and 4 pairs of the JCN nuts (F) and JCB bolts (E) .

Do not tighten all the way.

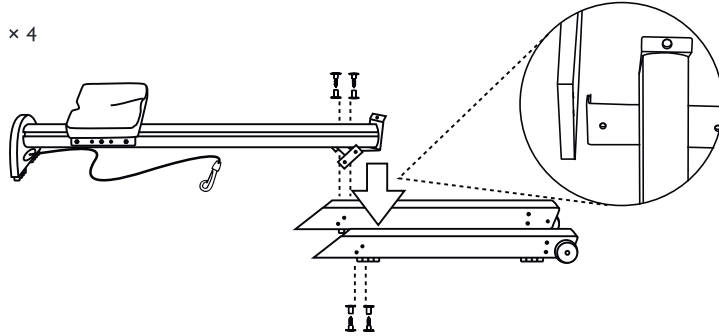
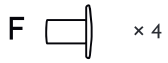
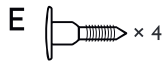

STEP 2

Place the tank assembly on the sub rails in the direction shown in the picture below.

Using the Allen key (M) and 4 pairs JCN nuts (F) and JCB bolts (E), attach the forward riser bracket to the rails. You may need to apply slight pressure to align bracket and rail holes. Do not tighten all the way.

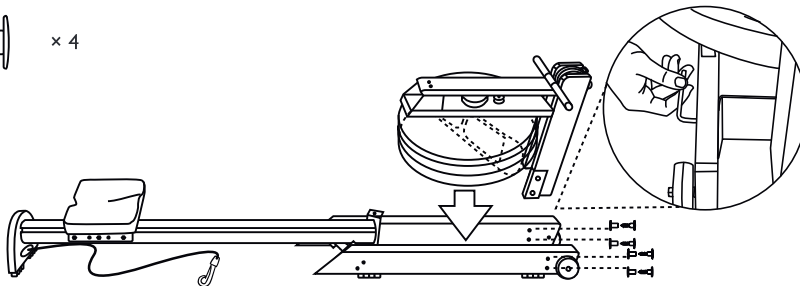
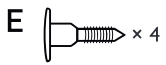

STEP 3

First remove the Back of Footboard Bolts (K) from behind the footboard. These bolts are used in steps 6 and 8.

Place the footboard on the rails, then attach the sensor cable to the monitor cable protruding from the back of the footboard.

The sensor cable may be taped to the back of the footboard. If so, remove the tape.

Feed the cable gently through the brackets so it does not get trapped between the footboard and tank assembly.

Align gold rivnuts on the tank assembly with the footboard's handle rest holes.

It may be necessary to slightly loosen the 2 bolts on the top deck to allow the footboard clearance.

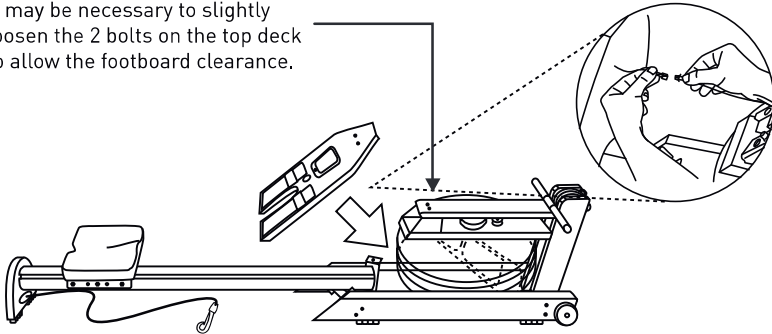

STEP 4

Using the 5mm Allen key (M), screw the handle rests and bolts (G & H) through the top of the footboard into the rivnuts mentioned in the previous step.

Do not over tighten these bolts.

*If you loosened the Top Deck Bolts in step 3 to align the footboard, first tighten them before tightening the handle bolts.

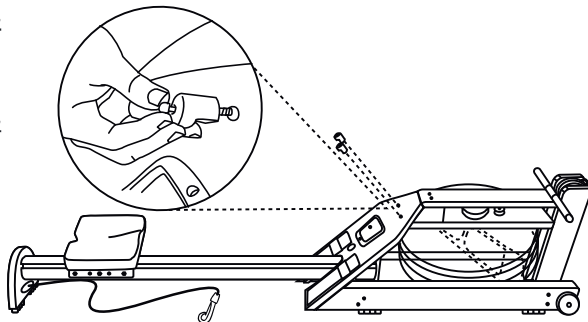
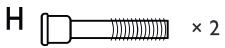

STEP 5

Tighten the footboard to the mono rail by screwing in the clamp bar bolt (I).

Do not tighten all the way.

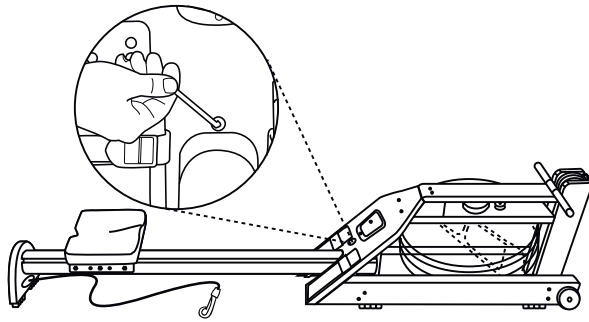
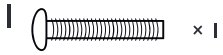

STEP 6

Stand the machine up. Insert 2 of the Back of Footboard Bolts into the footboard bracket and tighten.

Having kept all the bolts loose will allow easier alignment of the bolts and rivnut holes in the footboard.

Do not tighten all the way.

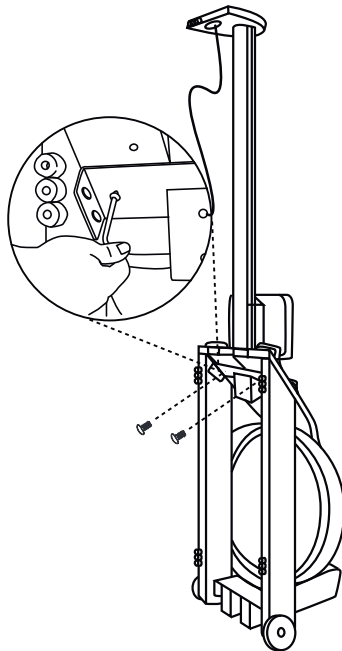

STEP 7

Insert the sub bracket bolt (J) through the "U" in the rail sub bracket (L) into the rail, to hold the bracket in place for step 8.

STEP 8

Screw in the rail sub bracket (L) under remaining back of footboard bolts (K).

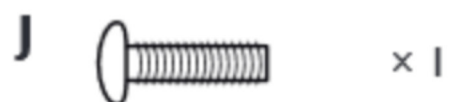

2

STEP 11

Unwrap the recoil belt from the forward riser bracket, making sure the belt runs below and around the pulley.

Attach the D ring on the recoil belt to the bungee hook.

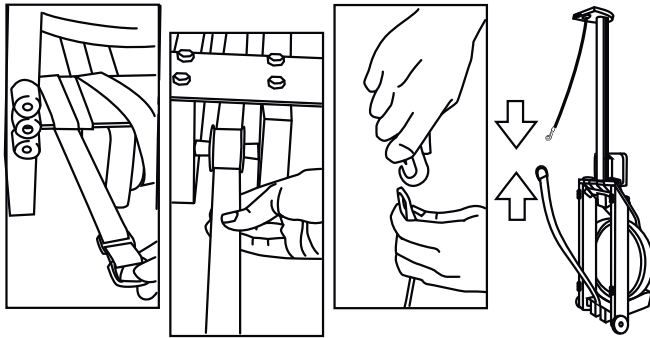

STEP 12

Lay the unit flat and remove the tank stopper from between the top and bottom deck. Use the included syphon pump (O) to fill the tank to the level indicated on the level gauge sticker located on the underside of the tank. (See next page.)

Do not fill above the "19" level mark.

Insert one purification tablet (P) every six months. Additional purification tablets are available upon request.

Moisten the tank stopper to assist with replacement.

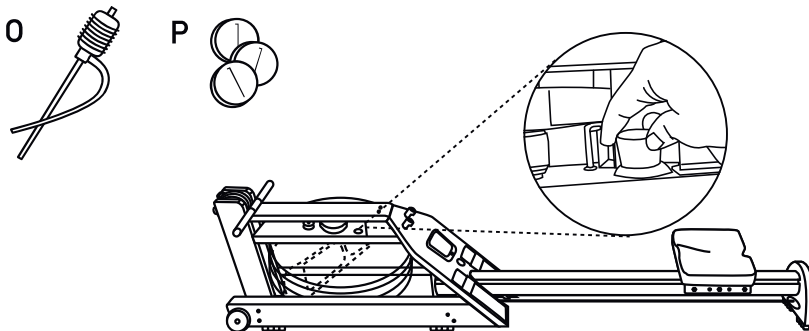

HOW TO FILL AND EMPTY THE TANK

- 1) To pump water, turn the knob clockwise to close valve as shown in figure A
- 2) Locate water source above (higher than) water destination:
 - See Figure B for filling tank
 - See Figure C for emptying tank
- 3) Squeeze pump 4-5 times until water flows
- 4) Turn knob counter-clockwise to allow air into the pump and end syphon.

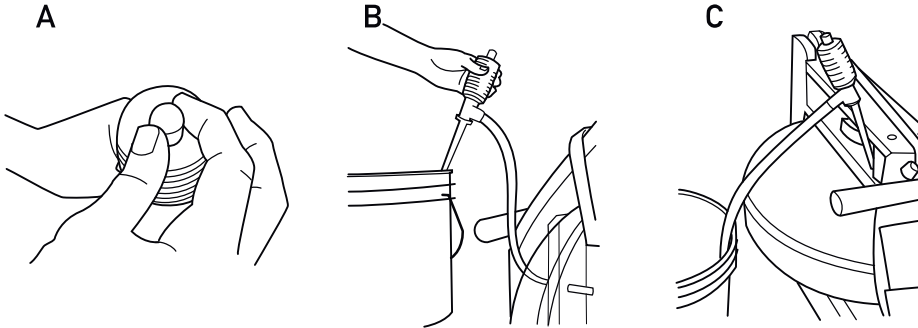

THE LEVEL GAUGE

The Level Gauge is positioned underneath the tank; to locate the Level Gauge sticker stand the machine up and look between the two wooden sub rails.

Information on the sticker includes the Serial Number, WaterRower contact information and the Water Level Gauge. The maximum level to fill the tank is Level 19 - **DO NOT** fill above this level. The standard Calibration Level is Level 17. This level provides enough resistance for all abilities, from an elite athlete to an elderly or youth user. It is recommended that all machines in a group class setting are filled to Level 17, this is to ensure all users are in the 'same boat', and race times remain accurate and consistent.

Recommended Water Level is Level 17

